

STATE OF ILLINOIS
DEPARTMENT OF TRANSPORTATION

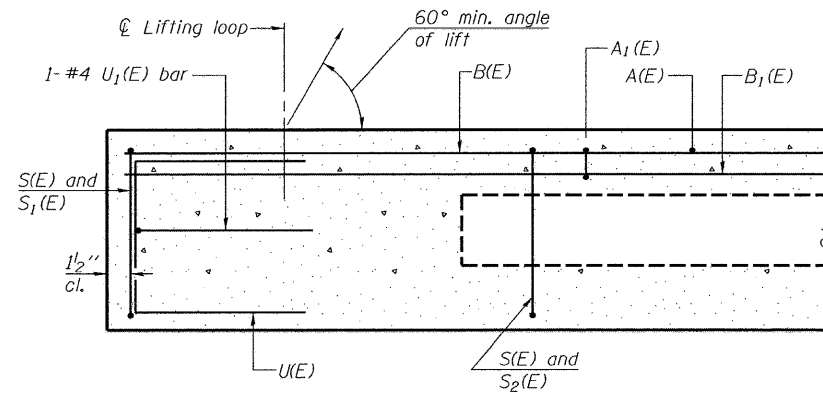

SECTION C-C

*Omit key on exterior face of outside beams

*Rail post anchor devices (specified elsewhere) to be cast into exterior face of outside beams.

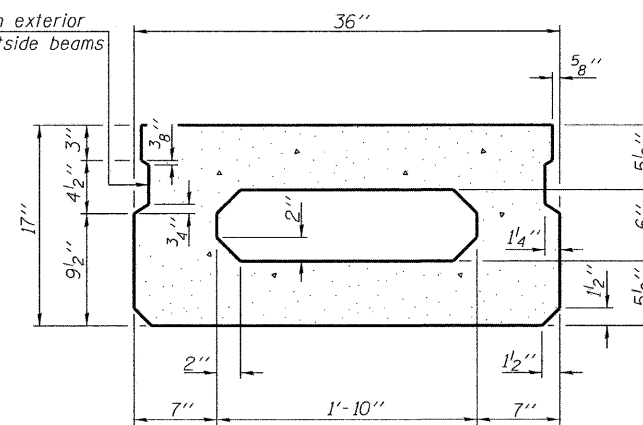

SECTION A-A
(Showing dimensions)

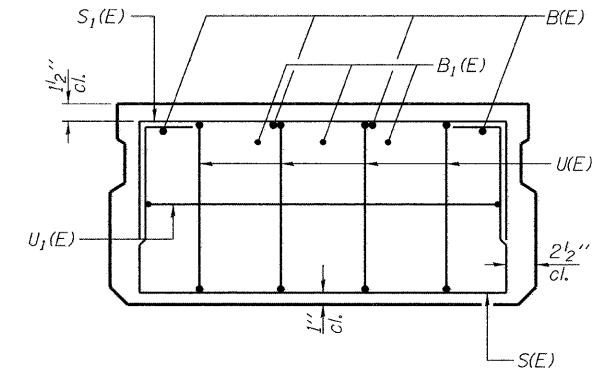

VIEW B-B

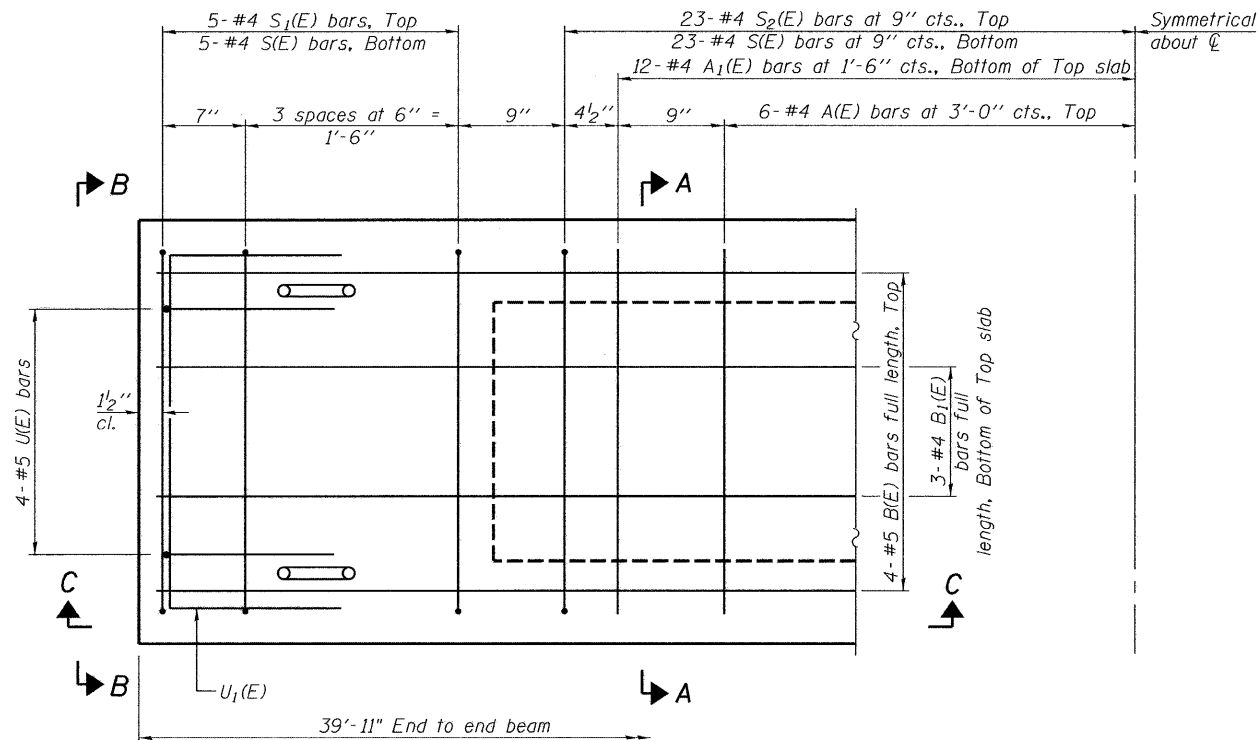

PLAN VIEW

Note: Spacing of S(E) and S2(E) bars may be adjusted up to 4" in the immediate area of the transverse tie diaphragms to miss the block outs for the transverse ties.

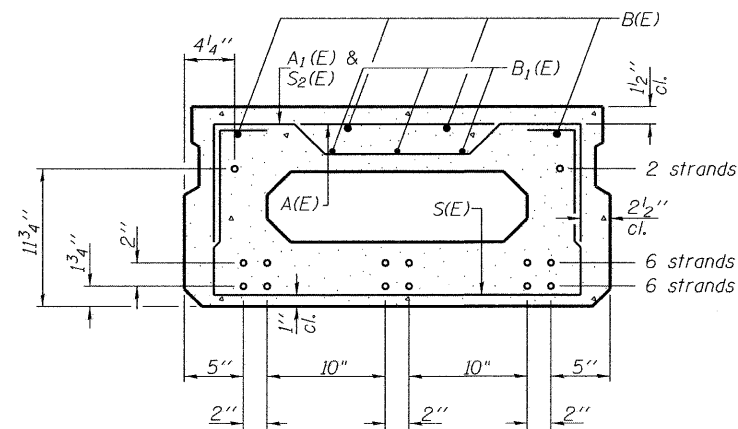

SECTION A-A
(Showing reinforcement and permissible strand locations)

Note: Place the number of strands specified in each row symmetrically about the centerline of beam in the permissible strand locations shown.

BAR LIST
ONE BEAM ONLY

(For information only)

Bar	No.	Size	Length	Shape
A(E)	12	#4	2'-7"	—
A1(E)	24	#4	2'-10"	~
B(E)	4	#5	39'-8"	—
B1(E)	3	#4	39'-8"	—
S(E)	56	#4	5'-9"	□
S1(E)	10	#4	4'-3"	□
S2(E)	46	#4	4'-6"	□
U(E)	8	#5	3'-8"	C
U1(E)	2	#4	5'-0"	□

Note: See sheet 6 of 12 for additional details and Bill of Material.

17"x36" PPC DECK BEAM
STRUCTURE NO. 068-3358
SPAN 2

DESIGNED CMF
CHECKED TMM
DRAWN RNH
CHECKED TMM

PD-1736-0 10-1-08

McDonough-Whitlow, P.C.
Consulting Engineers & Land Surveyors
138 East Wood Street
Hillsboro, IL 62049
Phone: 217.532.9233
Fax: 217.532.6300
PROFESSIONAL DESIGN No. 184-002754

SHEET NO. 4
12 SHEETS

F.A.S. RTE.	SECTION	COUNTY	TOTAL SHEETS	SHEET NO.
721	08-00128-00 BR	MONTGOMERY	22	10
CONTRACT NO. 93496				
FED. ROAD DIST. NO. ILLINOIS FED. AID PROJECT				