

Curled End Sections (Typ.)
See sheet 5 of 8 for details.
(Incidental)

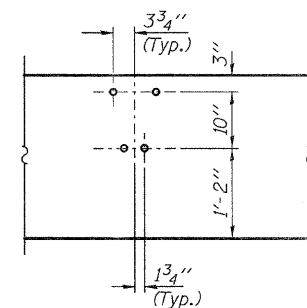

DETAIL A

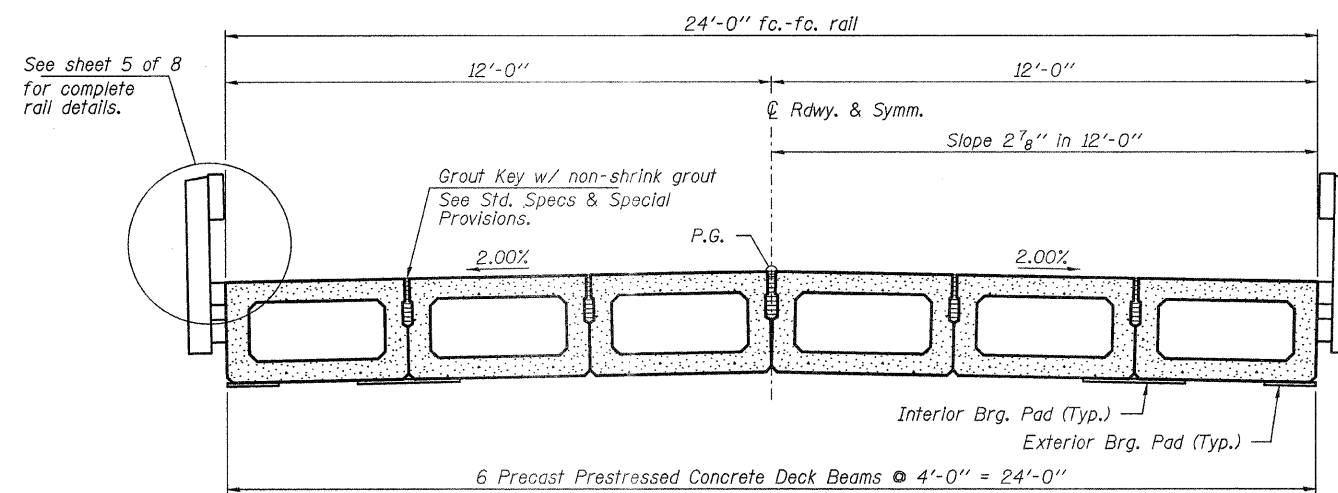

CROSS SECTION
See sheets 2 & 3 of 8 for Superstructure.

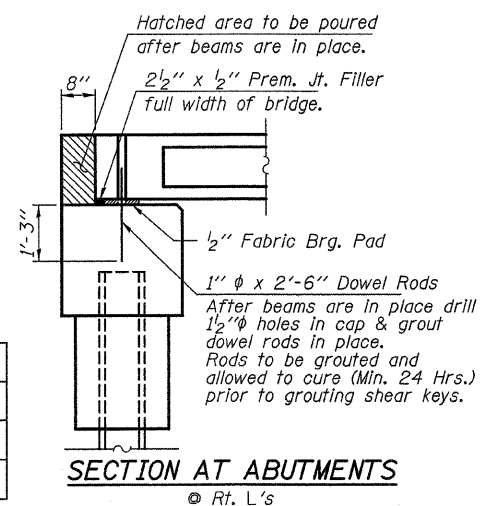

DESIGNED - S.M.S.
CHECKED - S.W.M.
DRAWN - D.A.B.
CHECKED - D.T.M.

SUPERSTRUCTURE DETAILS
STRUCTURE NO. 033-3309

HAMPTON, LENZINI & RENWICK, INC. CIVIL & STRUCTURAL ENGINEERS LAND SURVEYORS 3085 STEVENSON DRIVE, SUITE 201 SPRINGFIELD, ILLINOIS 62703 (217) 646-3400 PROJECT NUMBER: 08.0104.130 DATE: 01/21/09	SHEET NO. 4	T.R.	SECTION	COUNTY	TOTAL SHEETS	SHEET NO.
	8 SHEETS	376	08-01115-00-BR	HAMILTON	12	8
		BEAVER CREEK ROAD DISTRICT		CONTRACT NO. 99355		
		FED. ROAD DIST. NO.	ILLINOIS	FED. AID PROJECT BROS-065(44)		