

STATE OF ILLINOIS  
DEPARTMENT OF TRANSPORTATION  
DIVISION OF HIGHWAYS

**PROPOSED  
HIGHWAY PLANS**

F.A.I. ROUTE 74 (I-74)  
SECTION (81-1HVB & 81-1HVB-1) M-3

TYPE OF IMPROVEMENT: BRIDGE REPAIRS  
ROCK ISLAND COUNTY

C-92-086-12  
R 4 E (IOWA)

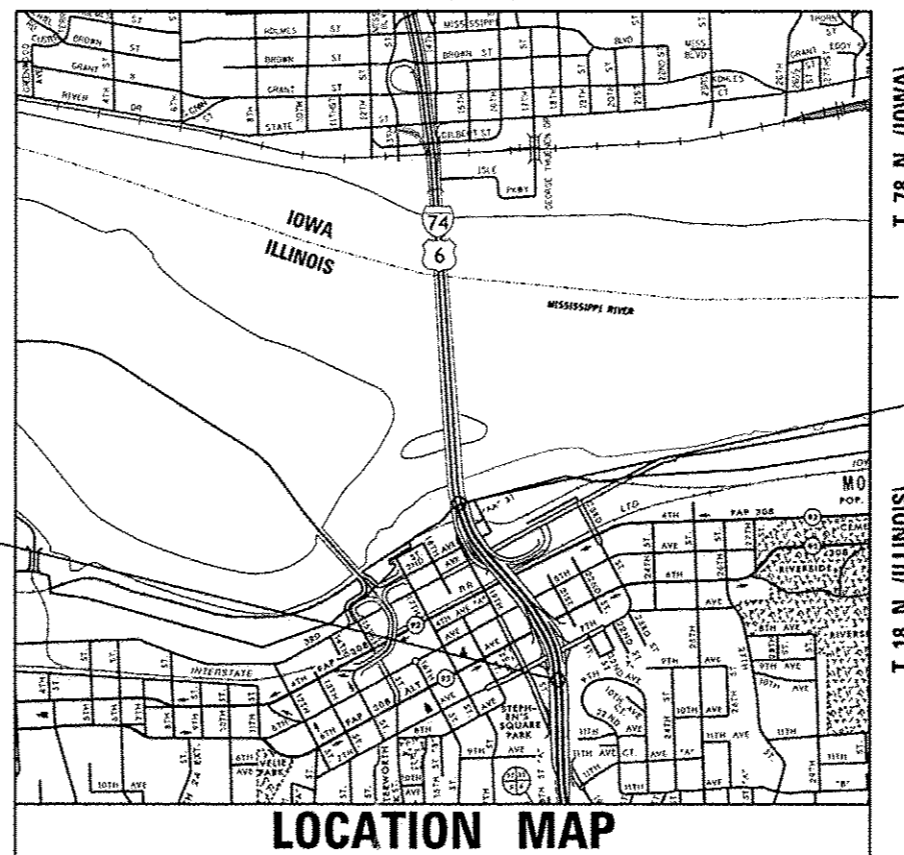

**LOCATION MAP**

R 1 W (ILLINOIS)  
(NOT TO SCALE)

**PROJECT LENGTH**

GROSS LENGTH = 2,859 FEET = 0.541 MILES  
NET LENGTH = 2,859 FEET = 0.541 MILES

F.A.I. RTE.	SECTION	COUNTY	TOTAL SHEETS	SHEET NO.
74	(81-1HVB & 81-1HVB-1) M-3	ROCK ISLAND	69	1
ILLINOIS			CONTRACT NO. 64H83	

D-92-058-12



LOCATION OF SECTION INDICATED THUS: [Symbol]

**INDEX OF SHEETS**  
SEE SHEET 2 FOR "INDEX OF SHEETS"

**HIGHWAY STANDARDS**  
SEE SHEET 2 FOR "HIGHWAY STANDARDS"

TOWNSHIP: MOLINE  
SECTIONS: 32 & 33

**DESCRIPTION OF IMPROVEMENT**  
IMPROVEMENT CONSISTS OF BRIDGE DECK  
PATCHING (FULL & PARTIAL DEPTH),  
RESURFACING AND  
STRUCTURAL STEEL REPAIRS TO:  
STR. NO's: 081-0142, 081-0143,  
081-0111, 081-0112, 081-0113 & 081-0114

**PREPARED BY:**

**OEI**  
QUIGG ENGINEERING INC.  
2351 SOUTH DIRKSEN PARKWAY  
SPRINGFIELD, ILLINOIS 62703  
(217) 670-0663 (P) / 217-679-2204 (F)  
PROJECT MANAGER:  
MICHAEL T. MATZKE, P.E.  
www.quiggengineering.com

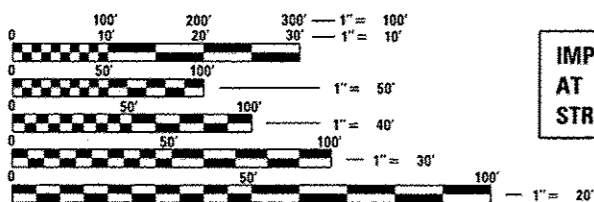

IMPROVEMENT/SECTION ENDS:  
AT SOUTH ABUTMENT OF  
STRUCTURES 081-0142 & 081-0143

FULL SIZE PLANS HAVE BEEN PREPARED USING STANDARD  
ENGINEERING SCALES. REDUCED SIZED PLANS WILL NOT  
CONFORM TO STANDARD SCALES. IN MAKING MEASUREMENTS  
ON REDUCED PLANS, THE ABOVE SCALES MAY BE USED.

CALL **J.U.L.I.E.** (JOINT UTILITY LOCATING INFORMATION FOR EXCAVATORS)  
48 Hours (2 working days) Before You Dig.  
TOLL FREE: 1 (800) 892-0123 OR 811

PROJECT ENGINEER: MAHMOUD ETEMADI (815) 284-5393

CONTRACT NO. 64H83

IMPROVEMENT/SECTION BEGINS:  
AT NORTH ABUTMENT OF  
STRUCTURES 081-0142 & 081-0143



STATE OF ILLINOIS  
DEPARTMENT OF TRANSPORTATION  
DIVISION OF HIGHWAYS  
SUBMITTED August 12, 2015  
Paul A. Kuster  
DEPUTY DIRECTOR OF HIGHWAYS, REGION ENGINEER  
Oct 2, 2015  
John D. Baranelli P.E.  
ENGINEER OF DESIGN AND ENVIRONMENT  
Oct 2, 2015  
Omer Osman P.E.  
DIRECTOR OF HIGHWAYS, CHIEF ENGINEER

PRINTED BY THE AUTHORITY  
OF THE STATE OF ILLINOIS

*Michael T. Matzke* Aug. 7, 2015  
MICHAEL T. MATZKE ILLINOIS P.E. 062-038471 DATE  
EXPIRES 11/30/2015

## INDEX OF SHEETS

SHEET NO.	DESCRIPTION
1	COVER SHEET
2	INDEX OF SHEETS AND IDOT HIGHWAY STANDARDS
3	GENERAL NOTES AND COMMITMENTS
4 - 7	SUMMARY OF QUANTITIES
8 - 11	SCHEDULE OF QUANTITIES
12	TYPICAL SECTIONS - STAGE 1A & 1B
13	STAGE 1A DETOUR - RIVER DRIVE
14 - 23	I-74 STAGING PLAN - STAGE 1A
24 - 33	I-74 STAGING PLAN - STAGE 1B
34	TYPICAL SECTIONS - STAGE 2A & 2B
35 - 37	I-74 STAGING PLAN - STAGE 2A
38	STAGE 2B DETOUR - 7TH AVENUE
39 - 41	I-74 STAGING PLAN - STAGE 2B
42	SIGN DETAILS
43	TEMPORARY CONCRETE BARRIER WALL DETAILS
44	URBAN LANE INSIDE CLOSURE, MULTILANE, 2-WAY, WITH MOUNTABLE MEDIAN (DIST STD 35.1)
45	INFORMATIONAL WARNING SIGNS (FOR NARROW TRAVEL LANES) (DIST STD 39.2)
46 - 48	TYPICAL PAVEMENT MARKINGS (DIST STD 41.1)
49	PAINTING DETAILS (DIST STD 44.1)
50 - 69	STRUCTURE PLANS

## IDOT HIGHWAY STANDARDS

STD NO.	DESCRIPTION
000001-06	STANDARD SYMBOLS, ABBREVIATIONS AND PATTERNS
001001-02	AREAS OF REINFORCEMENT BARS
001006	DECIMAL OF AN INCH AND OF A FOOT
635011-02	REFLECTOR MARKER AND MOUNTING DETAILS
642001-02	SHOULDER RUMBLE STRIPS, 16 IN.
701006-05	OFF-ROAD OPERATIONS, 2L, 2W, 15' (4.5 M) TO 24" (600 MM) FROM PAVEMENT EDGE
701101-04	OFF-ROAD OPERATIONS, MULTILANE, 15' (4.5 M) TO 24" (600 MM) FROM PAVEMENT EDGE
701400-08	APPROACH TO LANE CLOSURE, FREEWAY/EXPRESSWAY
701401-09	LANE CLOSURE, FREEWAY/EXPRESSWAY
701402-10	LANE CLOSURE, FREEWAY/EXPRESSWAY, WITH BARRIER
701411-09	LANE CLOSURE, MULTILANE, AT ENTRANCE OR EXIT RAMP, FOR SPEEDS $\geq$ 45 MPH
701426-07	LANE CLOSURE, MULTILANE, INTERMITTENT OR MOVING OPERATION, FOR SPEEDS $\geq$ 45 MPH
701428	TRAFFIC CONTROL, SETUP AND REMOVAL, FREEWAY/EXPRESSWAY
701451-03	RAMP CLOSURE FREEWAY/EXPRESSWAY
701501-06	URBAN LANE CLOSURE, 2L, 2W, UNDIVIDED
701601-09	URBAN LANE CLOSURE, MULTILANE, 1W OR 2W WITH NONTRAVERSABLE MEDIAN
701602-07	URBAN LANE CLOSURE, MULTILANE, 2W WITH BIDIRECTIONAL LEFT TURN LANE
701606-10	URBAN SINGLE LANE CLOSURE, MULTILANE, 2W WITH MOUNTABLE MEDIAN
701611	URBAN HALF ROAD CLOSURE, MULTILANE, 2W WITH MOUNTABLE MEDIAN
701801-05	LANE CLOSURE, MULTILANE 1W OR 2W CROSSWALK OR SIDEWALK CLOSURE
701901-04	TRAFFIC CONTROL DEVICES
704001-07	TEMPORARY CONCRETE BARRIER
720001-01	SIGN PANEL MOUNTING DETAILS
720006-04	SIGN PANEL ERECTION DETAILS
720011-01	METAL POSTS FOR SIGNS, MARKERS AND DELINEATORS
720021-02	SIGN PANELS, EXTRUDED ALUMINUM TYPE
728001-01	TELESCOPING STEEL SIGN SUPPORT
729001-01	APPLICATIONS OF TYPES A AND B METAL POSTS (FOR SIGNS & MARKERS)
780001-05	TYPICAL PAVEMENT MARKINGS

FILE NAME : S:\Projects\2012\085112-92-09\PIB 184 11 02 1-74 Bridge Repairs-Traffic Control Plans\000\000 Sheets\0264H83-1-Index.dgn  
 MODEL : Default  
 PLOT DRIVER : 12-92-09.PDF.plt



QUIGG ENGINEERING INC

USER NAME : walker	DESIGNED - MTM	REVISED -
FILE NAME : 0264H83-1-Index.dgn	DRAWN - RC	REVISED -
PLOT SCALE : 48,0000 / 1 in.	CHECKED - MCV	REVISED -
PLOT DATE : 8/7/2015	DATE - 7/31/2015	REVISED -

**STATE OF ILLINOIS  
DEPARTMENT OF TRANSPORTATION**

INDEX OF SHEETS AND IDOT HIGHWAY STANDARDS

SCALE: SHEET NO. OF SHEETS STA TO STA

F.A.T. RTE.	SECTION	COUNTY	TOTAL SHEETS	SHEET NO.
74	181-1HVB & 81-1HVB-1M-3	ROCK ISLAND	69	2
CONTRACT No. 64H83				
ILLINOIS FED. AID PROJECT				

## GENERAL NOTES

6A. ALL BORROW/WASTE/USE SITES MUST BE APPROVED BY THE DEPARTMENT PRIOR TO REMOVING ANY MATERIAL FROM THE PROJECT OR INITIATING ANY EARTHMOVING ACTIVITIES, INCLUDING TEMPORARY STOCKPILING OUTSIDE THE LIMITS OF CONSTRUCTION.

25. THE FOLLOWING MIXTURE REQUIREMENTS ARE APPLICABLE FOR THIS PROJECT:

MIXTURE USE(S):	BRIDGE DECK
	SURFACE
PG:	SBS PG 70-22
DESIGN AIR VOIDS	4.0% @ N90
MIXTURE COMPOSITION	IL-9.5
FRICTION AGGREGATE	MIXTURE E
20 YEAR ESAL	14.1
QUALITY MANAGEMENT PROGRAM TO BE USED	OCP
SUBLOT TONNAGE	900

28. THE AREA TO BE PRIMED SHALL BE LIMITED TO THAT WHICH CAN BE COVERED WITH HMA ON THE NEXT DAYS PRODUCTION, BUT NO MORE THAN FIVE DAYS IN ADVANCE OF THE PLACEMENT OF THE HMA, UNLESS APPROVED BY THE ENGINEER.

32. INSTALL RUMBLE STRIPS IN ALL SHOULDER IN ACCORDANCE WITH STATE STANDARD 642001. RUMBLE STRIPS SHALL BE PLACED ON SHOULDERS ON BOTH SIDES OF THE PAVEMENT.

44. THE CONTRACTOR SHALL SANDBLAST THE TOP OF THE BEAMS UPON REMOVAL OF THE BRIDGE DECK. THIS WORK WILL BE INCLUDED IN THE COST OF FULL-DEPTH DECK SLAB REPAIR.

88. PAVEMENT MARKING SHALL BE DONE ACCORDING TO STANDARD 780001, EXCEPT AS FOLLOWS:

1. ALL WORDS, SUCH AS "ONLY", SHALL BE 8 FEET HIGH.
2. ALL NON-FREEWAY ARROWS SHALL BE THE LARGE SIZE.
3. THE DISTANCE BETWEEN YELLOW NO-PASSING LINES SHALL BE 8 INCHES, NOT 7 INCHES AS SHOWN IN THE DETAIL OF TYPICAL LANE AND EDGE LINES.
4. CENTERLINE SKIP DASH PAVEMENT MARKING ON MULTI-LANE DIVIDED, MULTI-LANE UNDIVIDED, AND ONE-WAY ROADWAY SHALL BE ACCORDING TO DISTRICT STANDARD 41.1.

104. CADD DATA WILL BE AVAILABLE TO CONTRACTORS AND CONSULTANTS WORKING ON THIS PROJECT. THIS INFORMATION WILL BE PROVIDED UPON REQUEST AS MICROSTATION CADD FILES AND GEOPAK COORDINATE GEOMETRY FILES ONLY. IF DATA IS REQUIRED IN OTHER FORMATS IT WILL BE YOUR RESPONSIBILITY TO MAKE THESE CONVERSIONS. IF ANY DISCREPANCY OR INCONSISTENCY ARISES BETWEEN THE ELECTRONIC DATA AND THE INFORMATION ON THE HARD COPY, THE INFORMATION ON THE HARD COPY SHOULD BE USED. CONTACT THE DISTRICT'S PROJECT ENGINEER TO REQUEST THESE FILES.

106. TEMPORARY IMPACT ATTENUATORS WILL BE MEASURED AS EACH FOR EACH ATTENUATOR SUPPLIED ON THE JOB AS SPECIFIED IN THE PLANS, AND SHALL INCLUDE THE COST OF RENTING/OWNING THE ATTENUATOR FOR THE TIME REQUIRED ON THE JOB PLUS HAULING TO AND FROM THE PROJECT SITE, AS WELL AS ONE PLACEMENT AND REMOVAL FROM THE ROADWAY. THIS SHALL BE PAID FOR AT THE CONTRACT UNIT PRICE PER EACH FOR IMPACT ATTENUATORS, TEMPORARY OF THE TYPE SPECIFIED.

RELOCATE TEMPORARY IMPACT ATTENUATORS WILL BE PAID FOR AS EACH AND WILL BE PAID FOR EACH TIME THE ATTENUATOR IS REQUIRED BY STAGING TO BE PICKED UP AND MOVED TO A DIFFERENT LOCATION ON THE PROJECT, WHETHER IT IS TO ANOTHER LOCATION ON THE ROADWAY OR TO A STORAGE/STAGING LOCATION FOR THE PROJECT. THIS SHALL BE PAID FOR AT THE CONTRACT UNIT PRICE PER EACH FOR IMPACT ATTENUATORS, RELOCATE OF THE TYPE SPECIFIED.

107. THIS WORK SHALL BE DONE IN ACCORDANCE WITH SECTION 704 OF THE STANDARD SPECIFICATIONS. TEMPORARY CONCRETE BARRIER WILL BE MEASURED IN FEET ALONG THE CENTERLINE OF THE BARRIER AND SHALL INCLUDE THE COST OF RENTING/OWNING THE BARRIER FOR THE TIME REQUIRED ON THE JOB PLUS HAULING TO AND FROM THE PROJECT SITE, AS WELL AS ONE PLACEMENT AND REMOVAL FROM THE ROADWAY IN ACCORDANCE WITH SECTION 704 OF THE STANDARD SPECIFICATION. THIS SHALL BE PAID FOR AT THE CONTRACT UNIT PRICE PER FOOT FOR TEMPORARY CONCRETE BARRIER.

RELOCATE TEMPORARY CONCRETE BARRIER WILL BE PAID FOR IN FEET ALONG THE CENTERLINE OF THE BARRIER, AND WILL BE PAID FOR EACH TIME THE BARRIER IS REQUIRED BY STAGING TO BE PICKED UP AND MOVED TO A DIFFERENT LOCATION ON THE PROJECT, WHETHER IT IS TO ANOTHER LOCATION ON THE ROADWAY OR TO A STORAGE/STAGING LOCATION FOR THE PROJECT. THIS SHALL BE PAID FOR AT THE CONTRACT UNIT PRICE PER FOOT FOR RELOCATE TEMPORARY CONCRETE BARRIER.

200. DURING TIMES OF RAMP CLOSURES, EXISTING SIGNAL TIMINGS FOR INTERSECTIONS ALONG THE DETOUR ROUTES MAY REQUIRE ADJUSTMENT TO ACCOMMODATE INCREASED TRAFFIC IF DELAYS AT THE EXISTING SIGNALS ARE DETERMINED BY THE ENGINEER TO BE EXCESSIVE. THESE ADJUSTMENTS WILL BE COORDINATED BETWEEN THE DISTRICT 2 IDOT OPERATIONS DESIGN AND PLANNING ENGINEER (815-284-5468) AND THE CITY OF MOLINE.

THE FOLLOWING RATES OF APPLICATION HAVE BEEN ASSUMED IN CALCULATING PLAN QUANTITIES:

APPLICATION RATES	
POLYMERIZED HMA SURFACE COURSE.....	= 119 LBS / SQ YD / INCH
INCIDENTAL HMA SURFACING.....	= 112 LBS / SQ YD / INCH

## COMMITMENTS

1. TO ACCOMMODATE THE QUAD CITY MARATHON ON THE LAST WEEKEND IN SEPTEMBER 2016, ALL STAGE 1A AND 1B WORK SHALL BE COMPLETED BY SEPTEMBER 16, 2016. THIS INCLUDES ALL WORK ON RIVER DRIVE RAMPS.

FILE NAME = S:\Projects\2012 Jobs\12-02-09 P10 154 11 02 1-74 Bridge Repair-Traffic Control Plans\64001-6500 Sheets\0264HB3-ht-Genote.dgn  
 MODEL = D:\dwg  
 PLOT DRIVER = 12-02-09\_P10.dwg

 QUIGG ENGINEERING INC	USER NAME = walker	DESIGNED - MTM	REVISED -	STATE OF ILLINOIS DEPARTMENT OF TRANSPORTATION	GENERAL NOTES AND COMMITMENTS				F.A.I. RTE.	SECTION	COUNTY	TOTAL SHEETS	SHEET NO.
	FILE NAME = 0264HB3-ht-Genote.dgn	DRAWN - RG	REVISED -		74	(81-1HVB & 81-1HVB-1M-3)	ROCK ISLAND	69	3				
PLOT SCALE = 40,0000' / in.	CHECKED - MCV	REVISED -					CONTRACT No. 64HB3						
PLOT DATE = 8/7/2015	DATE - 7/31/2015	REVISED -	SCALE:		SHEET NO.	OF	SHEETS	STA	TO STA	ILLINOIS FED. AID PROJECT			



FILE NAME : S:\Projects\2012\_08\512-02-01 P1B 164 11 02 1-74 Bridge Repair-Traffic Control Plans\000\000 Sheets\0264\03-int-500.dgn  
 MODEL : Defeat  
 PLOT DRIVER : 12-02-01.LPS-plt.rtg

CODE NO.	ITEM	UNIT	TOTAL QUANTITY	CONSTRUCTION CODE	
				ROADWAY	BRIDGE
				0004	0014
				NONE	NONE
67000400	ENGINEER'S FIELD OFFICE, TYPE A	CAL MO	8	8	0
67100100	MOBILIZATION	L SUM	1	1	0
70100207	TRAFFIC CONTROL AND PROTECTION, STANDARD 701402	EACH	1	1	0
70100420	TRAFFIC CONTROL AND PROTECTION, STANDARD 701411	EACH	4	4	0
70100800	TRAFFIC CONTROL AND PROTECTION, STANDARD 701401	L SUM	1	1	0
70100820	TRAFFIC CONTROL AND PROTECTION, STANDARD 701451	L SUM	1	1	0
70102620	TRAFFIC CONTROL AND PROTECTION, STANDARD 701501	L SUM	1	1	0
70102625	TRAFFIC CONTROL AND PROTECTION, STANDARD 701606	L SUM	1	1	0
70102630	TRAFFIC CONTROL AND PROTECTION, STANDARD 701601	L SUM	1	1	0
70102632	TRAFFIC CONTROL AND PROTECTION, STANDARD 701602	L SUM	1	1	0
70102634	TRAFFIC CONTROL AND PROTECTION, STANDARD 701611	L SUM	1	1	0
70102640	TRAFFIC CONTROL AND PROTECTION, STANDARD 701801	L SUM	1	1	0
70106800	CHANGEABLE MESSAGE SIGN	CAL MO	16	16	0
70200100	NIGHTTIME WORK ZONE LIGHTING	L SUM	1	1	0

\* DENOTES "SPECIALTY ITEM"



USER NAME : swalsh	DESIGNED - MTM	REVISED -
FILE NAME : 0264\03-int-500.dgn	DRAWN - RC	REVISED -
PLOT SCALE : 100.0000 1/ in.	CHECKED - SDM	REVISED -
PLOT DATE : 8/7/2015	DATE - 7/31/2015	REVISED -

**STATE OF ILLINOIS  
DEPARTMENT OF TRANSPORTATION**

SUMMARY OF QUANTITIES				
SCALE:	SHEET NO.	OF	SHEETS	STA TO STA

F.A.T. RTE.	SECTION	COUNTY	TOTAL SHEETS	SHEET NO.
T4	81-1HVB & 81-1HVB-1M-3	ROCK ISLAND	69	5
				CONTRACT No. 64H83
ILLINOIS FED. AID PROJECT				





FILE NAME = S:\Projects\2012\JOBS\12-92-09\PTB 164 11 02 1-74 Bridge Repairs-Traffic Control Plans\CADD Sheets\0264H83-sht-Schedule.dgn  
 MODEL = Default  
 PLOT DRIVER = 12-92-09\_PDF.plt

40600275 BITUMINOUS MATERIALS (PRIME COAT)

POUND	LOCATION	LT / RT	LENGTH	WIDTH	APP. RATE	
WESTBOUND						
94	STAGE 2A	RT	750	2.5	0.05	LBS/SQ FT
65	STAGE 2B	LT	520	2.5	0.05	LBS/SQ FT
EASTBOUND						
34	STAGE 2A	RT	275	2.5	0.05	LBS/SQ FT
25	STAGE 2B	LT	200	2.5	0.05	LBS/SQ FT
218	TOTAL					

40800050 INCIDENTAL HOT-MIX ASPHALT SURFACING

TON	LOCATION	LT / RT	LENGTH	WIDTH	REMARKS
WESTBOUND					
12	STAGE 2A	RT	750	2.5	
8	STAGE 2B	LT	520	2.5	
EASTBOUND					
4	STAGE 2A	RT	275	2.5	
3	STAGE 2B	LT	200	2.5	
27	TOTAL				

44000153 HOT-MIX ASPHALT SURFACE REMOVAL, 1"

SQ YD	LOCATION	LT / RT	LENGTH	WIDTH	REMARKS
WESTBOUND					
208	STAGE 2A	RT	750	2.5	
144	STAGE 2B	LT	520	2.5	
EASTBOUND					
76	STAGE 2A	RT	275	2.5	
56	STAGE 2B	LT	200	2.5	
485	TOTAL				

64200116 SHOULDER RUMBLE STRIPS, 16 INCH

FOOT	LOCATION	LT / RT	REMARKS
WESTBOUND			
750	STAGE 2A	RT	
520	STAGE 2B	LT	
EASTBOUND			
275	STAGE 2A	RT	
200	STAGE 2B	LT	
1,745	TOTAL		

70301000 WORKZONE PAVEMENT MARKING REMOVAL

SQ FT	LOCATION	SIZE (INCH)	LENGTH (FOOT)	REMARKS
WESTBOUND				
329	STAGE 1A - SHEET 1	4	986	SOLID
474	STAGE 1A - SHEET 2	4	1,420	SOLID
51	STAGE 1A - SHEET 3	4	153	SOLID
481	STAGE 1A - SHEET 3	4	1,441	SOLID
137	STAGE 1A - SHEET 4	4	411	SOLID
60	STAGE 1A - SHEET 5	4	178	SOLID
38	STAGE 1A - SHEET 6	4	114	SOLID
EASTBOUND				
48	STAGE 1A - SHEET 2	4	142	SOLID
128	STAGE 1A - SHEET 4	4	382	SOLID
255	STAGE 1A - SHEET 4	4	765	SOLID
59	STAGE 1A - SHEET 5	4	177	SOLID
1,052	STAGE 1A - SHEET 6	4	3,156	SOLID
368	STAGE 1A - SHEET 7	4	1,104	SOLID
394	STAGE 1A - SHEET 8	4	1,182	SOLID
412	STAGE 1A - SHEET 9	4	1,234	SOLID
246	STAGE 1A - SHEET 10	4	738	SOLID
WESTBOUND				
10	STAGE 1B - SHEET 5	4	115	DOTTED 2' - 6'
595	STAGE 1B - SHEET 5	4	1,785	SOLID
38	STAGE 1B - SHEET 6	4	114	SOLID
EASTBOUND				
1,052	STAGE 1B - SHEET 6	4	3,156	SOLID
WESTBOUND				
287	STAGE 2A - SHEET 1 OF STAGE 1B	4	860	SOLID
478	STAGE 2A - SHEET 2 OF STAGE 1B	4	1,434	SOLID
335	STAGE 2A - SHEET 1	4	1,004	SOLID
131	STAGE 2A - SHEET 3	4	392	SOLID
38	STAGE 2A - SHEET 6 OF STAGE 1B	4	114	SOLID
EASTBOUND				
131	STAGE 2A - SHEET 1	4	393	SOLID
716	STAGE 2A - SHEET 3	4	2,147	SOLID
1,052	STAGE 2A - SHEET 6 OF STAGE 1B	4	3,156	SOLID
483	STAGE 2A - SHEET 7 OF STAGE 1B	4	1,448	SOLID
361	STAGE 2A - SHEET 8 OF STAGE 1B	4	1,081	SOLID
412	STAGE 2A - SHEET 9 OF STAGE 1B	4	1,234	SOLID
246	STAGE 2A - SHEET 10 OF STAGE 1B	4	738	SOLID

70301000 WORKZONE PAVEMENT MARKING REMOVAL

SQ FT	LOCATION	SIZE	LENGTH	REMARKS
WESTBOUND				
329	STAGE 2B - SHEET 1 OF STAGE 1A	4	986	SOLID
572	STAGE 2B - SHEET 2 OF STAGE 1A	4	1,715	SOLID
796	STAGE 2B - SHEET 1	4	2,388	SOLID
694	STAGE 2B - SHEET 2	4	2,080	SOLID
1,469	STAGE 2B - SHEET 3	4	4,406	SOLID
21	STAGE 2B - SHEET 3	4	249	30' SKIP 10' DASH
38	STAGE 2B - SHEET 6 OF STAGE 1A	4	114	SOLID
EASTBOUND				
430	STAGE 2B - SHEET 1	4	1,290	SOLID
689	STAGE 2B - SHEET 2	4	2,068	SOLID
1,544	STAGE 2B - SHEET 3	4	4,630	SOLID
7	STAGE 2B - SHEET 3	4	75	DOTTED 2' - 6'
1,052	STAGE 2B - SHEET 6 OF STAGE 1A	4	3,156	SOLID
557	STAGE 2B - SHEET 7 OF STAGE 1A	4	1,669	SOLID
394	STAGE 2B - SHEET 8 OF STAGE 1A	4	1,182	SOLID
412	STAGE 2B - SHEET 9 OF STAGE 1A	4	1,234	SOLID
246	STAGE 2B - SHEET 10 OF STAGE 1A	4	738	SOLID
REMOVING TEMPORARY MARKINGS IN FINAL LOCATIONS (SEE MODIFIED URETHANE PAVEMENT MARKING SCHEDULES FOR LOCATION)				
12,810	4" ITEMS	4	38,429	
1,461	6" ITEMS	4	4,383	
1,248	8" ITEMS	4	3,744	
35,666	TOTAL			



USER NAME = twalker	DESIGNED - MTM	REVISED -
FILE NAME = 0264H83-sht-Schedule.dgn	DRAWN - RG	REVISED -
PLOT SCALE = 20.0000' / in.	CHECKED - SDM	REVISED -
PLOT DATE = 8/7/2015	DATE - 7/31/2015	REVISED -

STATE OF ILLINOIS  
DEPARTMENT OF TRANSPORTATION

WORK ZONE PAVEMENT MARKING REMOVAL SCHEDULE

SCALE:	SHEET NO.	OF	SHEETS	STA	TO STA
--------	-----------	----	--------	-----	--------

F.A.I. RTE.	SECTION	COUNTY	TOTAL SHEETS	SHEET NO.
74	(81-IHVB & 81-IHVB-1)M-3	ROCK ISLAND	69	8
CONTRACT No. 64H83			ILLINOIS FED. AID PROJECT	



70300220 TEMPORARY PAVEMENT MARKING - LINE 4"

FOOT	LOCATION	LT / CL / RT	ACTUAL LENGTH	TYPE	REMARKS
WESTBOUND					
986	STAGE 1A - SHEET 1	RT		EDGE LINE (WHITE)	SOLID
571	STAGE 1A - SHEET 2	CL		EDGE LINE (WHITE)	SOLID
320	STAGE 1A - SHEET 2	RT		EDGE LINE (WHITE)	SOLID - RAMP
142	STAGE 1A - SHEET 2	RT		EDGE LINE (WHITE)	SOLID - RAMP
682	STAGE 1A - SHEET 2	CL		EDGE LINE (WHITE)	SOLID
1,441	STAGE 1A - SHEET 3	CL		EDGE LINE (WHITE)	SOLID
765	STAGE 1A - SHEET 4	CL		EDGE LINE (WHITE)	SOLID
138	STAGE 1A - SHEET 4	RT		EDGE LINE (WHITE)	SOLID - GORE
411	STAGE 1A - SHEET 4	LT / RT		EDGE LINE (WHITE)	SOLID - RAMP
244	STAGE 1A - SHEET 4	LT		EDGE LINE (YELLOW)	SOLID
1,421	STAGE 1A - SHEET 5	LT		EDGE LINE (WHITE)	SOLID
1,391	STAGE 1A - SHEET 5	LT		EDGE LINE (YELLOW)	SOLID
114	STAGE 1A - SHEET 5	LT		EDGE LINE (WHITE)	SOLID
EASTBOUND					
122	STAGE 1A - SHEET 4	LT		EDGE LINE (YELLOW)	SOLID
21	STAGE 1A - SHEET 4	LT		EDGE LINE (WHITE)	SOLID
1,403	STAGE 1A - SHEET 5	LT		EDGE LINE (YELLOW)	SOLID
1,447	STAGE 1A - SHEET 5	LT		EDGE LINE (WHITE)	SOLID
3,156	STAGE 1A - SHEET 6	CL		EDGE LINE (WHITE)	SOLID
827	STAGE 1A - SHEET 7	CL		EDGE LINE (WHITE)	SOLID
586	STAGE 1A - SHEET 7	LT		EDGE LINE (WHITE)	SOLID - RAMP
128	STAGE 1A - SHEET 7	RT		EDGE LINE (WHITE)	SOLID - GORE
128	STAGE 1A - SHEET 7	CL		EDGE LINE (WHITE)	SOLID - GORE
101	STAGE 1A - SHEET 8	RT		EDGE LINE (WHITE)	SOLID - GORE
1,081	STAGE 1A - SHEET 8	CL		EDGE LINE (WHITE)	SOLID
1,234	STAGE 1A - SHEET 9	CL		EDGE LINE (WHITE)	SOLID
738	STAGE 1A - SHEET 10	RT		EDGE LINE (WHITE)	SOLID
WESTBOUND					
986	STAGE 1B - SHEET 1	LT		EDGE LINE (YELLOW)	SOLID
1,434	STAGE 1B - SHEET 2	CL		EDGE LINE (YELLOW)	SOLID
1,441	STAGE 1B - SHEET 3	CL		EDGE LINE (YELLOW)	SOLID
1,043	STAGE 1B - SHEET 4	CL / RT		EDGE LINE (YELLOW)	SOLID
16	STAGE 1B - SHEET 4	RT		EDGE LINE (YELLOW)	SOLID
114	STAGE 1B - SHEET 4	RT		EDGE LINE (WHITE)	SOLID - GORE
114	STAGE 1B - SHEET 4	RT		EDGE LINE (WHITE)	SOLID - GORE
66	STAGE 1B - SHEET 4	RT		EDGE LINE (WHITE)	SOLID
83	STAGE 1B - SHEET 4	RT	332	RAMP ENT (WHITE)	DOTTED 2' - 6'
1,414	STAGE 1B - SHEET 5	RT		EDGE LINE (YELLOW)	SOLID
115	STAGE 1B - SHEET 5	RT	457	RAMP ENT (WHITE)	DOTTED 2' - 6'
521	STAGE 1B - SHEET 5	RT		EDGE LINE (WHITE)	SOLID
460	STAGE 1B - SHEET 5	RT		EDGE LINE (YELLOW)	SOLID - RAMP
122	STAGE 1B - SHEET 5	RT		EDGE LINE (WHITE)	SOLID - GORE
392	STAGE 1B - SHEET 5	RT		EDGE LINE (WHITE)	SOLID
1,015	STAGE 1B - SHEET 5	RT		EDGE LINE (WHITE)	SOLID - RAMP
114	STAGE 1B - SHEET 6	LT		EDGE LINE (YELLOW)	SOLID
EASTBOUND					
131	STAGE 1B - SHEET 4	RT		EDGE LINE (WHITE)	SOLID
1,207	STAGE 1B - SHEET 5	RT		EDGE LINE (WHITE)	SOLID - RAMP
154	STAGE 1B - SHEET 5	RT		EDGE LINE (WHITE)	SOLID - GORE
590	STAGE 1B - SHEET 5	RT		EDGE LINE (YELLOW)	SOLID - RAMP
114	STAGE 1B - SHEET 5	RT	457	RAMP EXIT (WHITE)	DOTTED 2' - 6'
974	STAGE 1B - SHEET 5	RT		EDGE LINE (WHITE)	SOLID
1,454	STAGE 1B - SHEET 5	RT		EDGE LINE (YELLOW)	SOLID
3,156	STAGE 1B - SHEET 6	CL		EDGE LINE (YELLOW)	SOLID
1,448	STAGE 1B - SHEET 7	CL		EDGE LINE (YELLOW)	SOLID
1,081	STAGE 1B - SHEET 8	CL		EDGE LINE (YELLOW)	SOLID
1,234	STAGE 1B - SHEET 9	CL		EDGE LINE (YELLOW)	SOLID
738	STAGE 1B - SHEET 10	LT		EDGE LINE (YELLOW)	SOLID
WESTBOUND					
984	STAGE 2A - SHEET 1 OF STAGE 1B	LT		EDGE LINE (YELLOW)	SOLID
1,434	STAGE 2A - SHEET 2 OF STAGE 1B	CL		EDGE LINE (YELLOW)	SOLID
1,444	STAGE 2A - SHEET 1	RT		EDGE LINE (YELLOW)	SOLID
1,191	STAGE 2A - SHEET 1	RT		EDGE LINE (WHITE)	SOLID
572	STAGE 2A - SHEET 2	RT		EDGE LINE (WHITE)	SOLID
1,046	STAGE 2A - SHEET 2	RT		EDGE LINE (YELLOW)	SOLID
1,000	STAGE 2A - SHEET 3	LT		EDGE LINE (YELLOW)	SOLID

70300220 TEMPORARY PAVEMENT MARKING - LINE 4"

FOOT	LOCATION	LT / CL / RT	ACTUAL LENGTH	TYPE	REMARKS
392	STAGE 2A - SHEET 3	LT / RT		EDGE LINE (YELLOW)	SOLID
719	STAGE 2A - SHEET 3	RT		EDGE LINE (WHITE)	SOLID
461	STAGE 2A - SHEET 3	RT		EDGE LINE (YELLOW)	SOLID - RAMP
318	STAGE 2A - SHEET 3	RT		EDGE LINE (WHITE)	SOLID
1,445	STAGE 2A - SHEET 3	RT		EDGE LINE (WHITE)	SOLID - RAMP
248	STAGE 2A - SHEET 3	CL	992	CENTERLINE (WHITE)	10' SKIP 30' DASH
EASTBOUND					
578	STAGE 2A - SHEET 1	RT		EDGE LINE (YELLOW)	SOLID
823	STAGE 2A - SHEET 1	RT		EDGE LINE (WHITE)	SOLID
1,028	STAGE 2A - SHEET 2	RT		EDGE LINE (YELLOW)	SOLID
594	STAGE 2A - SHEET 2	RT		EDGE LINE (WHITE)	SOLID
131	STAGE 2A - SHEET 2	RT		EDGE LINE (WHITE)	SOLID
1,244	STAGE 2A - SHEET 3	RT		EDGE LINE (WHITE)	SOLID - RAMP
590	STAGE 2A - SHEET 3	RT		EDGE LINE (YELLOW)	SOLID - RAMP
154	STAGE 2A - SHEET 3	RT		EDGE LINE (WHITE)	SOLID - GORE
113	STAGE 2A - SHEET 3	RT	452	RAMP EXIT (WHITE)	DOTTED 2' - 6'
974	STAGE 2A - SHEET 3	RT		EDGE LINE (WHITE)	SOLID
1,450	STAGE 2A - SHEET 3	LT / RT		EDGE LINE (YELLOW)	SOLID
3,156	STAGE 2A - SHEET 6 OF STAGE 1B	CL		EDGE LINE (YELLOW)	SOLID
1,448	STAGE 2A - SHEET 7 OF STAGE 1B	CL		EDGE LINE (YELLOW)	SOLID
1,081	STAGE 2A - SHEET 8 OF STAGE 1B	CL		EDGE LINE (YELLOW)	SOLID
1,234	STAGE 2A - SHEET 9 OF STAGE 1B	CL		EDGE LINE (YELLOW)	SOLID
738	STAGE 2A - SHEET 10 OF STAGE 1B	LT		EDGE LINE (YELLOW)	SOLID
WESTBOUND					
986	STAGE 2B - SHEET 1 OF STAGE 1A	RT		EDGE LINE (WHITE)	SOLID
891	STAGE 2B - SHEET 2 OF STAGE 1A	RT		EDGE LINE (WHITE)	SOLID
142	STAGE 2B - SHEET 2 OF STAGE 1A	RT		EDGE LINE (WHITE)	SOLID
682	STAGE 2B - SHEET 2 OF STAGE 1A	CL		EDGE LINE (WHITE)	SOLID
1,440	STAGE 2B - SHEET 1	LT		EDGE LINE (WHITE)	SOLID
948	STAGE 2B - SHEET 1	LT		EDGE LINE (YELLOW)	SOLID
1,042	STAGE 2B - SHEET 2	LT		EDGE LINE (WHITE)	SOLID
1,038	STAGE 2B - SHEET 2	LT		EDGE LINE (YELLOW)	SOLID
1,427	STAGE 2B - SHEET 3	LT		EDGE LINE (YELLOW)	SOLID - RAMP
755	STAGE 2B - SHEET 3	RT		EDGE LINE (WHITE)	SOLID - GORE
318	STAGE 2B - SHEET 3	RT		EDGE LINE (WHITE)	SOLID - GORE
461	STAGE 2B - SHEET 3	RT		EDGE LINE (YELLOW)	SOLID - RAMP
1,445	STAGE 2B - SHEET 3	RT		EDGE LINE (WHITE)	SOLID
249	STAGE 2B - SHEET 3	CL	996	CENTERLINE (WHITE)	10' SKIP 30' DASH
EASTBOUND					
709	STAGE 2B - SHEET 1	LT		EDGE LINE (YELLOW)	SOLID
581	STAGE 2B - SHEET 1	LT		EDGE LINE (WHITE)	SOLID
1,032	STAGE 2B - SHEET 2	LT		EDGE LINE (WHITE)	SOLID
1,036	STAGE 2B - SHEET 2	LT		EDGE LINE (YELLOW)	SOLID
1,244	STAGE 2B - SHEET 3	RT		EDGE LINE (WHITE)	SOLID - RAMP
279	STAGE 2B - SHEET 3	RT		EDGE LINE (WHITE)	SOLID - GORE
590	STAGE 2B - SHEET 3	RT		EDGE LINE (YELLOW)	SOLID - RAMP
1,112	STAGE 2B - SHEET 3	LT		EDGE LINE (WHITE)	SOLID
1,405	STAGE 2B - SHEET 3	LT		EDGE LINE (YELLOW)	SOLID
75	STAGE 2B - SHEET 3	CL	299	RAMP EXIT (WHITE)	DOTTED 2' - 6'
3,156	STAGE 2B - SHEET 6 OF STAGE 1A	CL		EDGE LINE (WHITE)	SOLID
827	STAGE 2B - SHEET 7 OF STAGE 1A	LT / RT		EDGE LINE (WHITE)	SOLID
586	STAGE 2B - SHEET 7 OF STAGE 1A	LT / RT		EDGE LINE (WHITE)	SOLID
128	STAGE 2B - SHEET 7 OF STAGE 1A	RT		EDGE LINE (WHITE)	SOLID
128	STAGE 2B - SHEET 7 OF STAGE 1A	CL		EDGE LINE (WHITE)	SOLID
101	STAGE 2B - SHEET 8 OF STAGE 1A	RT		EDGE LINE (WHITE)	SOLID
1,081	STAGE 2B - SHEET 8 OF STAGE 1A	CL		EDGE LINE (WHITE)	SOLID
1,234	STAGE 2B - SHEET 9 OF STAGE 1A	LT / RT		EDGE LINE (WHITE)	SOLID
738	STAGE 2B - SHEET 10 OF STAGE 1A	RT		EDGE LINE (WHITE)	SOLID
TEMPORARY MARKINGS IN FINAL LOCATIONS					
MATCH LOCATIONS IN ITEM NO 78009004 - MODIFIED URETHANE PAVEMENT MARKING LINE 4					
38,429					
MATCH LOCATIONS IN ITEM NO 78009006 - MODIFIED URETHANE PAVEMENT MARKING LINE 6					
4,383					
MATCH LOCATIONS IN ITEM NO 78009008 - MODIFIED URETHANE PAVEMENT MARKING LINE 8					
3,744					
142,341 TOTAL					

FILE NAME = S:\Projects\2012\JOBS\12-92-09 PTB 164 11 02 1-74 Bridge Repairs-Traffic Control Plans\CADD\CADD Sheets\0264H83-sht-Schedule.dgn  
 MODEL = Default  
 PLOT DRIVER = 12-92-091.PDF.plt



USER NAME = twalker	DESIGNED - MTM	REVISED -
FILE NAME = 0264H83-sht-Schedule.dgn	DRAWN - RG	REVISED -
PLOT SCALE = 20.0000' / in.	CHECKED - SDM	REVISED -
PLOT DATE = 8/7/2015	DATE - 7/31/2015	REVISED -

STATE OF ILLINOIS  
DEPARTMENT OF TRANSPORTATION

SCHEDULE OF QUANTITIES

SCALE:	SHEET NO.	OF	SHEETS	STA	TO STA
--------	-----------	----	--------	-----	--------

F.A.I. RE.	SECTION	COUNTY	TOTAL SHEETS	SHEET NO.
74	(81-IHV & 81-IHV-1)M-3	ROCK ISLAND	69	9
CONTRACT No.			64H83	
ILLINOIS FED. AID PROJECT				

FILE NAME = S:\Projects\2012\JOBS\12-92-09\PTB 164 11 02 1-74 Bridge Repairs-Traffic Control Plans\CADD\Sheet\0264H83-sht-Schedule.dgn  
 MODEL = Default  
 PLOT DRIVER = 12-92-09\_PDF.plt

70400100	TEMPORARY CONCRETE BARRIER			
FOOT	LOCATION	LT / RT	SECTIONS	DESCRIPTION
	WESTBOUND			
101.36	STAGE 1A - SHEET 4	RT	8	100' TANGENT
430.72	STAGE 1A - SHEET 4 / 5	RT	34	TAPER
1,444.38	STAGE 1A - SHEET 5 / 6	LT / RT	114	TAPER TO END
	EASTBOUND			
1,317.68	STAGE 1A - SHEET 4 / 5	LT / RT	104	TAPER TO END
253.40	STAGE 1A SHEET 5 / 6	RT	20	TAPER
101.36	STAGE 1A - SHEET 6	RT	8	100' TANGENT
	WESTBOUND			
772.87	STAGE 2A - SHEET 1 - 3	RT	61	ADDITIONAL NEED
4,421.8	TOTAL			
4,425.0	USE			

70600250	IMPACT ATTENUATORS, TEMPORARY (NON-REDIRECTIVE), TEST LEVEL 3	
EACH	LOCATION	LT / RT
	EASTBOUND	
1	STAGE 1A - SHEET 6	RT
	WESTBOUND	
1	STAGE 1B - SHEET 4	LT
2	TOTAL	

78009004	MODIFIED URETHANE PAVEMENT MARKING LINE - 4"		
FOOT	LT / RT	TYPE	REMARKS
	WESTBOUND		
988	RT	EDGE LINE (WHITE)	SOLID
982	LT	EDGE LINE (YELLOW)	SOLID
1,112	RT	EDGE LINE (WHITE)	SOLID
1,438	LT	EDGE LINE (YELLOW)	SOLID
311	RT	EDGE LINE (WHITE)	SOLID
1,445	RT	EDGE LINE (WHITE)	SOLID
1,437	LT	EDGE LINE (YELLOW)	SOLID
537	RT	EDGE LINE (WHITE)	SOLID
902	RT	EDGE LINE (WHITE)	SOLID
1,039	LT	EDGE LINE (YELLOW)	SOLID
389	RT	EDGE LINE (YELLOW)	SOLID
400	RT	EDGE LINE (WHITE)	SOLID
1,445	RT	EDGE LINE (WHITE)	SOLID
1,427	LT	EDGE LINE (YELLOW)	SOLID
461	RT	EDGE LINE (YELLOW)	SOLID
236	RT	EDGE LINE (WHITE)	SOLID
236	LT	EDGE LINE (YELLOW)	SOLID

70600260	IMPACT ATTENUATORS, TEMPORARY (FULLY REDIRECTIVE, NARROW), TEST LEVEL 3	
EACH	LOCATION	LT / RT
1	WESTBOUND	
	STAGE 1A - SHEET 4	
1	TOTAL	

702	EASTBOUND		
FOOT	LT / RT	TYPE	REMARKS
702	RT	EDGE LINE (WHITE)	SOLID
710	LT	EDGE LINE (YELLOW)	SOLID
534	RT	EDGE LINE (WHITE)	SOLID
873	RT	EDGE LINE (WHITE)	SOLID
1,035	LT	EDGE LINE (YELLOW)	SOLID
382	RT	EDGE LINE (YELLOW)	SOLID
819	RT	EDGE LINE (WHITE)	SOLID
1,244	RT	EDGE LINE (WHITE)	SOLID
1,442	LT	EDGE LINE (YELLOW)	SOLID
590	RT	EDGE LINE (YELLOW)	SOLID
3,156	RT	EDGE LINE (WHITE)	SOLID
3,156	LT	EDGE LINE (YELLOW)	SOLID
937	RT	EDGE LINE (WHITE)	SOLID
510	RT	EDGE LINE (WHITE)	SOLID
1,449	LT	EDGE LINE (YELLOW)	SOLID
380	RT	EDGE LINE (WHITE)	SOLID
699	RT	EDGE LINE (WHITE)	SOLID
1,082	LT	EDGE LINE (YELLOW)	SOLID
1,233	RT	EDGE LINE (WHITE)	SOLID
1,235	LT	EDGE LINE (YELLOW)	SOLID
738	RT	EDGE LINE (WHITE)	SOLID
738	LT	EDGE LINE (YELLOW)	SOLID
38,429	TOTAL		

70400200	RELOCATE TEMPORARY CONCRETE BARRIER			
FOOT	LOCATION	LT / RT	SECTIONS	DESCRIPTION
	WESTBOUND			
101.36	STAGE 1B - SHEET 4	LT	8	100' TANGENT
240.73	STAGE 1B - SHEET 4	LT / RT	19	TAPER
1,609.09	STAGE 1B - SHEET 4 - 6	RT	127	TAPER TO END
	EASTBOUND			
1,457.05	STAGE 1B - SHEET 4 - 5	LT / RT	115	TAPER TO END
114.05	STAGE 1B - SHEET 5 - 6	LT	9	TAPER
101.36	STAGE 1B - SHEET 6	LT	8	100' TANGENT
	WESTBOUND			
101.36	STAGE 2A - SHEET 1	LT	8	100' TANGENT
240.73	STAGE 2A - SHEET 1	LT / RT	19	TAPER
1,089.62	STAGE 2A - SHEET 1 - 3	RT	86	TAPER TO END
	EASTBOUND			
1,849.82	STAGE 2A - SHEET 1 - 3	LT / RT	146	TAPER TO END
240.73	STAGE 2A - SHEET 3	LT	19	TAPER
101.36	STAGE 2A - SHEET 3	LT	8	100' TANGENT
	WESTBOUND			
101.36	STAGE 2B - SHEET 1	RT	8	100' TANGENT
240.73	STAGE 2B - SHEET 1	RT	19	TAPER
1,786.47	STAGE 2B - SHEET 1 - 3	RT	141	TAPER TO END
	EASTBOUND			
1,849.82	STAGE 2B - SHEET 1 - 3	LT / RT	146	TAPER TO END
215.39	STAGE 2B - SHEET 3	LT	17	TAPER
101.36	STAGE 2B - SHEET 3	LT	8	100' TANGENT
11,542.4	TOTAL			
11,550.0	USE			

70600350	IMPACT ATTENUATORS, RELOCATE (NON-REDIRECTIVE), TEST LEVEL 3	
EACH	LOCATION	LT / RT
1	EASTBOUND	
	STAGE 1B - SHEET 6	
1	WESTBOUND	
	STAGE 2A - SHEET 1	
1	EASTBOUND	
	STAGE 2A - SHEET 3	
1	WESTBOUND	
	STAGE 2B - SHEET 1	
1	EASTBOUND	
	STAGE 2B - SHEET 3	
5	TOTAL	

ESTIMATED QUANTITY (SEE "TYPICAL PAVEMENT MARKINGS" AND "PAINTING DETAILS" FOR PLACEMENT)



USER NAME = twalker	DESIGNED - MTM	REVISED -
FILE NAME = D264H83-sht-Schedule.dgn	DRAWN - RG	REVISED -
PLOT SCALE = 20.0000' / in.	CHECKED - SDM	REVISED -
PLOT DATE = 8/7/2015	DATE - 7/31/2015	REVISED -

STATE OF ILLINOIS  
DEPARTMENT OF TRANSPORTATION

SCHEDULE OF QUANTITIES

SCALE:	SHEET NO.	OF	SHEETS	STA	TO STA
--------	-----------	----	--------	-----	--------

F.A.I. RTE.	SECTION	COUNTY	TOTAL SHEETS	SHEET NO.
74	181-1HVB & 81-1HVB-1M-3	ROCK ISLAND	69	10
CONTRACT No.			64H83	
ILLINOIS FED. AID PROJECT				

FILE NAME = S:\Projects\2012\JOBS\12-92-09\PTB 164 11 02 1-74 Bridge Repairs-Traffic Control Plans\CADD Sheets\0264H83-sht-Schedule.dgn  
 MODEL = Default  
 PLOT DRIVER = 12-92-09.PDF.pltcf9

78009006	MODIFIED URETHANE PAVEMENT MARKING LINE - 6"			
FOOT	LT / CL / RT	TYPE	LENGTH	REMARKS
WESTBOUND				
246	CL	CENTERLINE (WHITE)	985	30' SKIP 10' DASH
359	CL	CENTERLINE (WHITE)	1,434	30' SKIP 10' DASH
360	CL	CENTERLINE (WHITE)	1,440	30' SKIP 10' DASH
261	CL	CENTERLINE (WHITE)	1,043	30' SKIP 10' DASH
355	CL	CENTERLINE (WHITE)	1,419	30' SKIP 10' DASH
59	CL	CENTERLINE (WHITE)	236	30' SKIP 10' DASH
EASTBOUND				
177	CL	CENTERLINE (WHITE)	706	30' SKIP 10' DASH
258	CL	CENTERLINE (WHITE)	1,032	30' SKIP 10' DASH
363	CL	CENTERLINE (WHITE)	1,450	30' SKIP 10' DASH
789	CL	CENTERLINE (WHITE)	3,156	30' SKIP 10' DASH
362	CL	CENTERLINE (WHITE)	1,448	30' SKIP 10' DASH
28	RT	CENTERLINE (WHITE)	111	30' SKIP 10' DASH
270	CL	CENTERLINE (WHITE)	1,081	30' SKIP 10' DASH
309	CL	CENTERLINE (WHITE)	1,234	30' SKIP 10' DASH
185	CL	CENTERLINE (WHITE)	738	30' SKIP 10' DASH
4,381	TOTAL			

ESTIMATED QUANTITY (SEE "TYPICAL PAVEMENT MARKINGS" AND "PAINTING DETAILS" FOR PLACEMENT)

78009008	MODIFIED URETHANE PAVEMENT MARKING LINE - 8"		
FOOT	LT / CL / RT	TYPE	REMARKS
WESTBOUND			
227	RT	EDGE LINE (WHITE)	GORE
227	RT	EDGE LINE (WHITE)	GORE
289	RT	EDGE LINE (WHITE)	GORE
290	RT	EDGE LINE (WHITE)	GORE
319	RT	EDGE LINE (WHITE)	GORE
318	RT	EDGE LINE (WHITE)	GORE
EASTBOUND			
179	RT	EDGE LINE (WHITE)	GORE
179	RT	EDGE LINE (WHITE)	GORE
279	RT	EDGE LINE (WHITE)	GORE
277	RT	EDGE LINE (WHITE)	GORE
300	RT	EDGE LINE (WHITE)	GORE
300	RT	EDGE LINE (WHITE)	GORE
280	RT	EDGE LINE (WHITE)	GORE
280	RT	EDGE LINE (WHITE)	GORE
3,744	TOTAL		

ESTIMATED QUANTITY (SEE "TYPICAL PAVEMENT MARKINGS" AND "PAINTING DETAILS" FOR PLACEMENT)

78300100	PAVEMENT MARKING REMOVAL					
SQ FT	LOCATION	LT / CL / RT	TYPE	SIZE (IN)	LENGTH (FOOT)	REMARKS
WESTBOUND						
82	STAGE 1A - SHEET 4	LT	EDGE LINE (YELLOW)	4	244	SOLID
35	STAGE 1A - SHEET 4	CL	CENTERLINE (WHITE)	6	276	30' SKIP 10' DASH
322	STAGE 1A - SHEET 4	RT	EDGE LINE (WHITE)	8	483	GORE
926	STAGE 1A - SHEET 5	LT	EDGE LINE (YELLOW)	8	1,389	SOLID
EASTBOUND						
41	STAGE 1A - SHEET 4	LT	EDGE LINE (YELLOW)	4	122	SOLID
469	STAGE 1A - SHEET 5	LT	EDGE LINE (YELLOW)	4	1,405	SOLID
WESTBOUND						
66	STAGE 1B - SHEET 4	RT	EDGE LINE (WHITE)	8	407	GORE
231	STAGE 1B - SHEET 5	RT	EDGE LINE (WHITE)	4	692	SOLID
EASTBOUND						
23	STAGE 1B - SHEET 4	RT	EDGE LINE (WHITE)	4	68	SOLID
361	STAGE 1B - SHEET 5	RT	EDGE LINE (WHITE)	4	1,083	SOLID
WESTBOUND						
397	STAGE 2A - SHEET 1	RT	EDGE LINE (WHITE)	4	1,189	SOLID
179	STAGE 2A - SHEET 2	RT	EDGE LINE (WHITE)	4	537	SOLID
152	STAGE 2A - SHEET 2	RT	EDGE LINE (WHITE)	8	228	GORE
118	STAGE 2A - SHEET 3	RT	EDGE LINE (WHITE)	4	354	SOLID
EASTBOUND						
274	STAGE 2A - SHEET 1	RT	EDGE LINE (WHITE)	4	821	SOLID
178	STAGE 2A - SHEET 2	RT	EDGE LINE (WHITE)	4	532	SOLID
199	STAGE 2A - SHEET 2	RT	EDGE LINE (WHITE)	8	298	GORE
44	STAGE 2A - SHEET 2	RT	EDGE LINE (WHITE)	4	131	SOLID
WESTBOUND						
317	STAGE 2B - SHEET 1	RT	EDGE LINE (WHITE)	4	949	SOLID
EASTBOUND						
236	STAGE 2B - SHEET 1	RT	EDGE LINE (WHITE)	4	708	SOLID
4,650	TOTAL					



USER NAME = twalker	DESIGNED - MTM	REVISED -
FILE NAME = 0264H83-sht-Schedule.dgn	DRAWN - RG	REVISED -
PLOT SCALE = 20.0000' / in.	CHECKED - SDM	REVISED -
PLOT DATE = 8/7/2015	DATE - 7/31/2015	REVISED -

STATE OF ILLINOIS  
DEPARTMENT OF TRANSPORTATION

SCHEDULE OF QUANTITIES			
SCALE:	SHEET NO.	OF SHEETS	STA TO STA

F.A.I. RTE.	SECTION	COUNTY	TOTAL SHEETS	SHEET NO.
74	(81-IHVB & 81-IHVB-1)M-3	ROCK ISLAND	69	11
CONTRACT No. 64H83				
ILLINOIS FED. AID PROJECT				

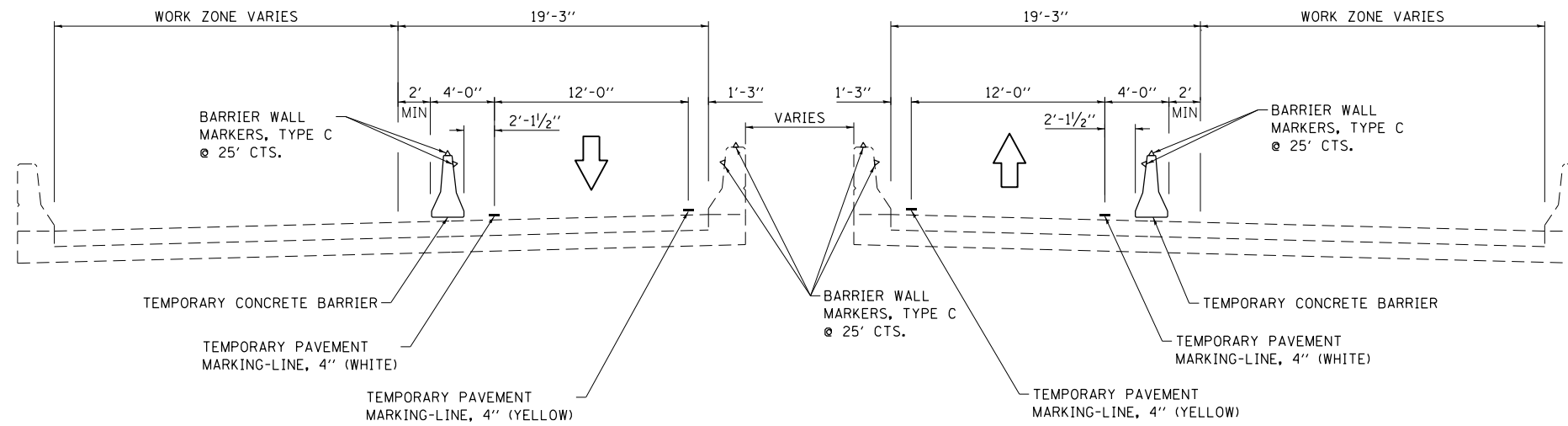

**EASTBOUND**

**WESTBOUND**

**TYPICAL SECTION – STAGE 1A**

**STAGING GENERAL NOTES**

1. TRAFFIC CONTROL DEVICES SHOWN ON THESE PLANS MAY BE ADJUSTED TO FIT FIELD CONDITIONS WITH PRIOR APPROVAL FROM THE ENGINEER AND TRAFFIC OPERATIONS.
2. TRAFFIC CONTROL SHALL BE IN ACCORDANCE WITH APPLICABLE STANDARDS. CHANNELIZING DEVICES SHALL BE IN ACCORDANCE WITH IDOT HWY STD 701901.
3. THE CONTRACTOR SHALL PLACE CHECK BARRICADES AS NOTED ON HWY STD 701401.
4. NO EQUIPMENT OR MATERIALS ARE TO BE STORED WITHIN THE 2' BUFFER AREA BEHIND THE UNPINNED TEMPORARY CONCRETE BARRIER.

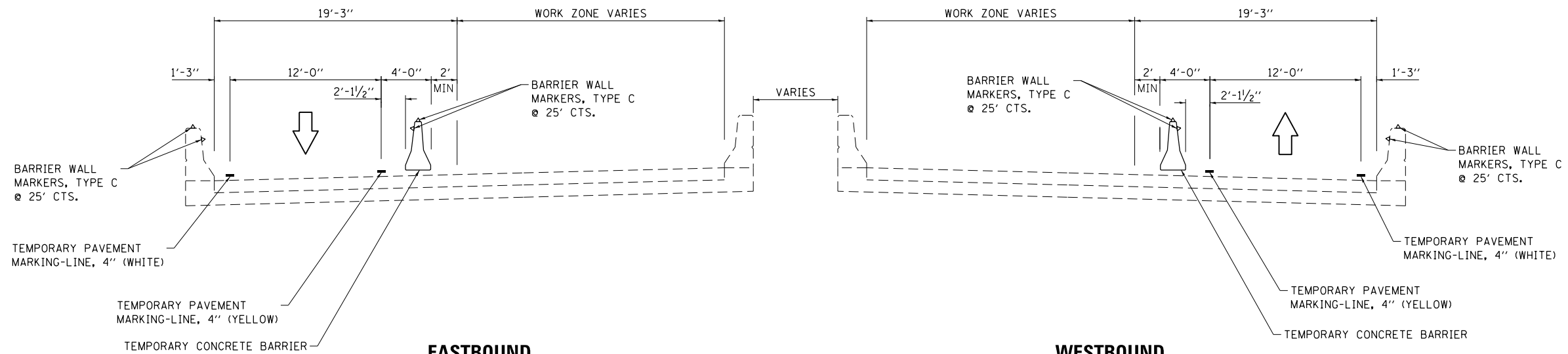

**EASTBOUND**

**WESTBOUND**

**TYPICAL SECTION – STAGE 1B**

FILE NAME = S:\Projects\2012\JOBS\12-92-09\PTB 164 11 02 1-74 Bridge Repairs-Traffic Control Plans\CADD\CADD Sheets\0264H83-sht-Staging\_Typical.dgn  
 MODEL = Default  
 PLOT DRIVER = 12-92-09\_PDF.plt



USER NAME = twalker	DESIGNED - MTM	REVISED -
FILE NAME = 0264H83-sht-Staging_Typical.dgn	DRAWN - RG	REVISED -
PLOT SCALE = 10.0000' / in.	CHECKED - MCV	REVISED -
PLOT DATE = 8/7/2015	DATE - 7/31/2015	REVISED -

**STATE OF ILLINOIS  
DEPARTMENT OF TRANSPORTATION**

**TYPICAL SECTIONS  
STAGE 1A & 1B**

SCALE: SHEET NO. OF SHEETS STA TO STA

F.A.I. RTE.	SECTION	COUNTY	TOTAL SHEETS	SHEET NO.
74	(81-IHVB & 81-IHVB-1)M-3	ROCK ISLAND	69	12
CONTRACT No. 64H83				
ILLINOIS FED. AID PROJECT				

**NOTES:**

- FOR TEMPORARY RAMP CLOSURE, USE STANDARD 701451 FOR ADDITIONAL GUIDANCE, EXCEPT USE "RAMP CLOSED AHEAD" INSTEAD OF "ROAD CLOSED AHEAD" OR "RAMP CLOSED" INSTEAD OF "EXIT CLOSED".
- FINAL SIGN LOCATIONS TO BE DETERMINED IN THE FIELD BY THE ENGINEER. LOCATIONS SHOWN ARE APPROXIMATE AND FOR PLAN PURPOSES ONLY.
- ALL SIGNS SHALL BE SET AT A 7 FOOT MOUNTING HEIGHT ON TELSPAR OR CHANNEL SIGN POSTS.

**LEGEND**

- WORK ZONE
- RIVER DRIVE ENTRANCE RAMP DETOUR ROUTE
- RIVER DRIVE EXIT RAMP DETOUR ROUTE
- PORTABLE CHANGEABLE MESSAGE SIGN (PCMS)
- TYPE III BARRICADE
- DRUM W/ STEADY BURN LIGHT
- SIGN

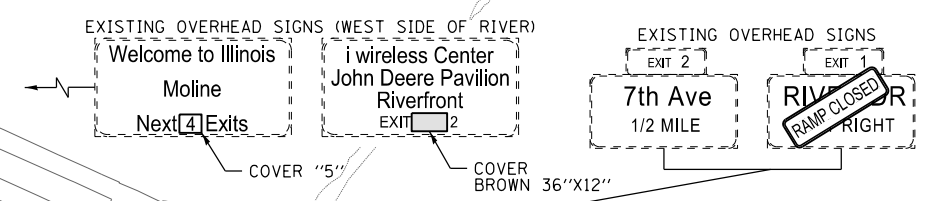
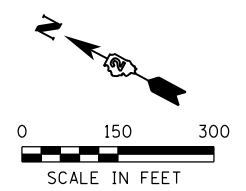

PCMS LOCATED AT THE FORMER TOLLBOOTH TO READ:  
RIVER DR EXIT CLOSED / USE 7TH AVE EXIT

**SIGN LEGEND**

7th Ave	SPECIAL-(O) 24x12	DETOUR AHEAD	W20-2-(O) 48
→	M6-1R-(O) 21x15	RAMP CLOSED AHEAD	(O) 48
←	M6-1L-(O) 21x15	ROAD CLOSED	R11-2-(O) 48x30
↑	M6-3-(O) 21x15	74	M1-1 24x24
↗	M6-2L-(O) 21x15	RIVER DRIVE	SEE SIGN DETAILS
↘	M5-1R-(O) 21x15	(O) = ORANGE SIGN	
↙	M5-1L-(O) 21x15	•SIGN DIMENSIONS ARE GIVEN IN INCHES	
TO	M4-5-(O) 24x12		
EAST	M3-2-(BL) 24x12		
WEST	M3-4-(BL) 24x12		
RAMP CLOSED	(O) 72x18		

PCMS TO READ:  
RIVER DR EXIT CLOSED / USE 7TH AVE EXIT

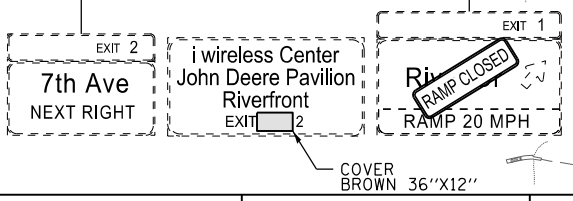

FILE NAME = S:\Projects\2012\0815\12-92-09 PTB 164 11 02 1-74 Bridge Repairs-Traffic Control Plans\CADD\CADD Sheets\0264H83-sht-Staging-1A Detour.dgn  
MODEL = Sheet  
PLOT DRIVER = 12-92-091.PDF.plt



USER NAME = twalker	DESIGNED - MTM	REVISED -
FILE NAME = 0264H83-sht-Staging-1A Detour.dgn	DRAWN - RG	REVISED -
PLOT SCALE = 300.0000' / in.	CHECKED - MCV	REVISED -
PLOT DATE = 8/7/2015	DATE - 7/31/2015	REVISED -

**STATE OF ILLINOIS  
DEPARTMENT OF TRANSPORTATION**







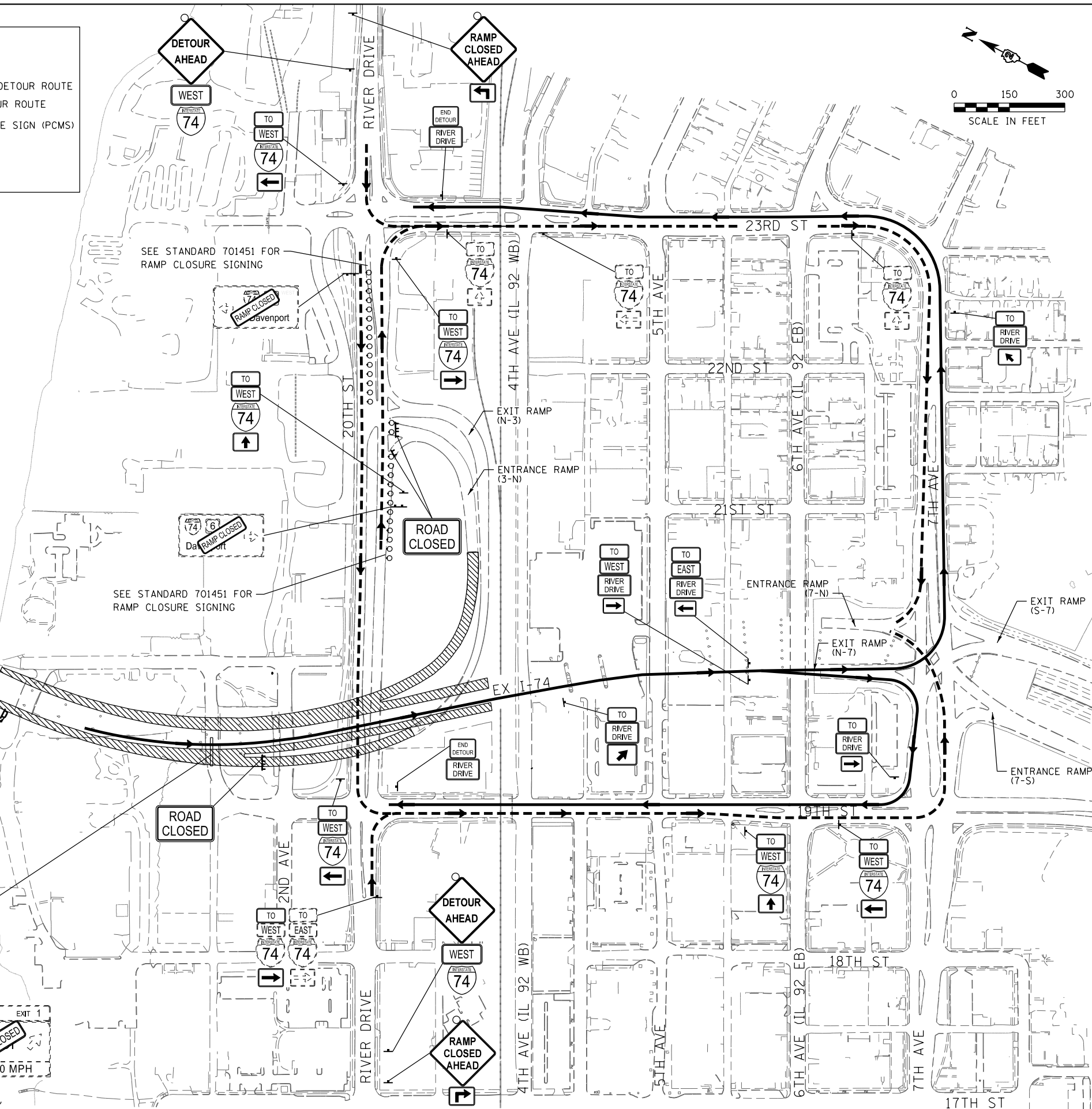

**STAGE 1A DETOUR  
RIVER DRIVE**

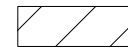
SCALE:	SHEET NO.	OF SHEETS	STA	TO STA
--------	-----------	-----------	-----	--------

F.A.I. RTE.	SECTION	COUNTY	TOTAL SHEETS	SHEET NO.
74	181-IHV-B & 81-IHV-B-1M-3	ROCK ISLAND	69	13
CONTRACT No. 64H83				
ILLINOIS FED. AID PROJECT				

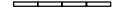

**STAGING LEGEND**

-  WORK ZONE
-  TRAFFIC FLOW
-  SIGN
-  DIRECTIONAL INDICATOR BARRICADE W/ STEADY BURN MONODIRECTIONAL LIGHT
-  TYPE II BARRICADE, DRUM W/ STEADY BURN MONODIRECTIONAL LIGHT
-  TYPE III BARRICADE
-  TEMPORARY CONCRETE BARRIER
-  ARROW BOARD

**NOTES:**

1. ALL OFFSETS ARE MEASURED FROM CENTER SKIP DASH LINE IN RESPECTIVE DIRECTIONS.
2. THE CONTRACTOR SHALL PLACE CHECK BARRICADES AS NOTED ON HWY STD 701401.
3. BARRIER WALL OFFSETS ARE MEASURED TO THE CONSTRUCTION SIDE OF BARRIER WALL.

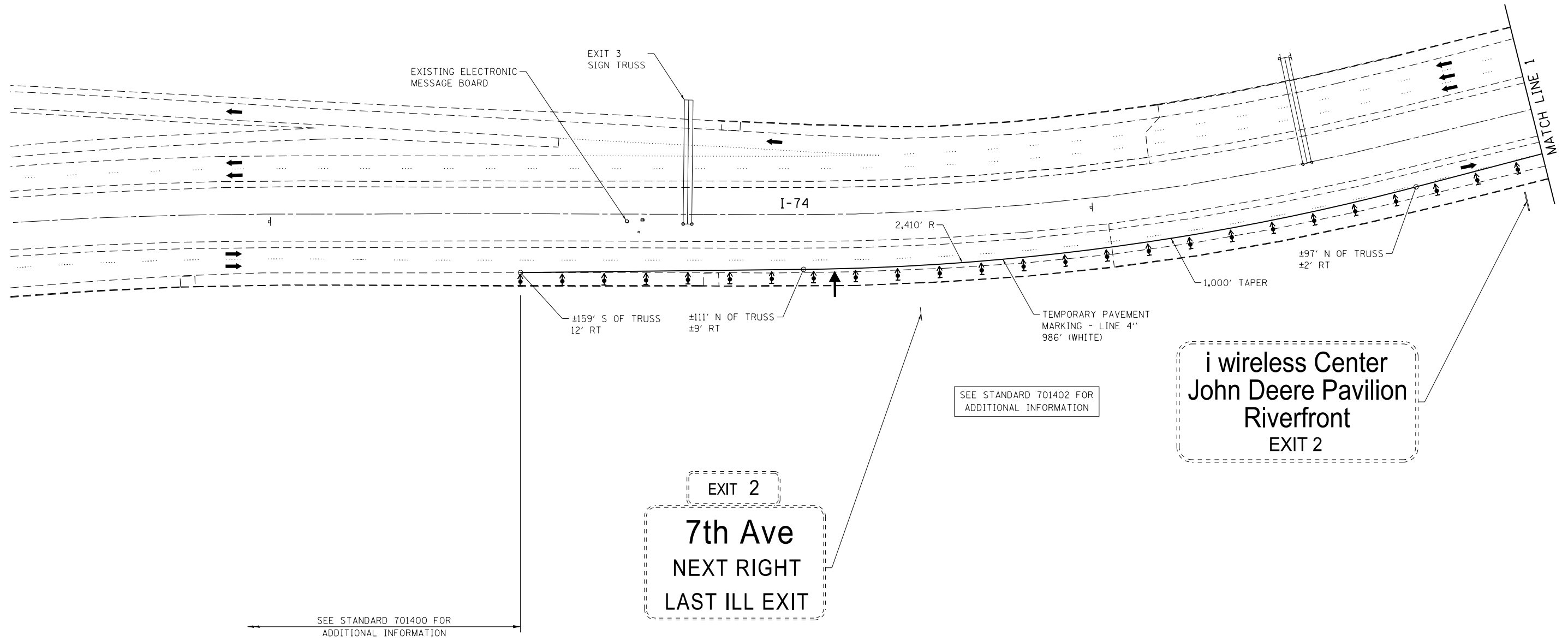
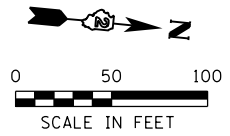

FILE NAME = S:\Projects\2012\JOBS\12-92-09\PTB 164 11 02 1-74 Bridge Repairs-Traffic Control\Plans\CADD\Sheet\0264H83-sht-Staging-1A01.dgn  
 MODEL = Default  
 PLOT DRIVER = 12-92-091.PDF.pltcf9



USER NAME = twalker	DESIGNED - MTM	REVISED -
FILE NAME = 0264H83-sht-Staging-1A01.dgn	DRAWN - RG	REVISED -
PLOT SCALE = 100.0000' / 1in.	CHECKED - MCV	REVISED -
PLOT DATE = 8/7/2015	DATE - 7/31/2015	REVISED -

**STATE OF ILLINOIS  
DEPARTMENT OF TRANSPORTATION**

<b>I-74 STAGING PLAN STAGE 1A</b>	
SCALE:	TO STA
SHEET NO. 1 OF 10 SHEETS	STA

F.A.I. RTE.	SECTION	COUNTY	TOTAL SHEETS	SHEET NO.
74	(81-1HVB & 81-1HVB-1JM-3)	ROCK ISLAND	69	14
CONTRACT No. 64H83				
ILLINOIS FED. AID PROJECT				

# Davenport - Bettendorf EXITS

- Grant St - State St 1
- Middle Rd - Locust St 2
- Kimberly Rd - Spruce Hills Dr 3
- 53rd St 4

EXIT 2  
7th Avenue

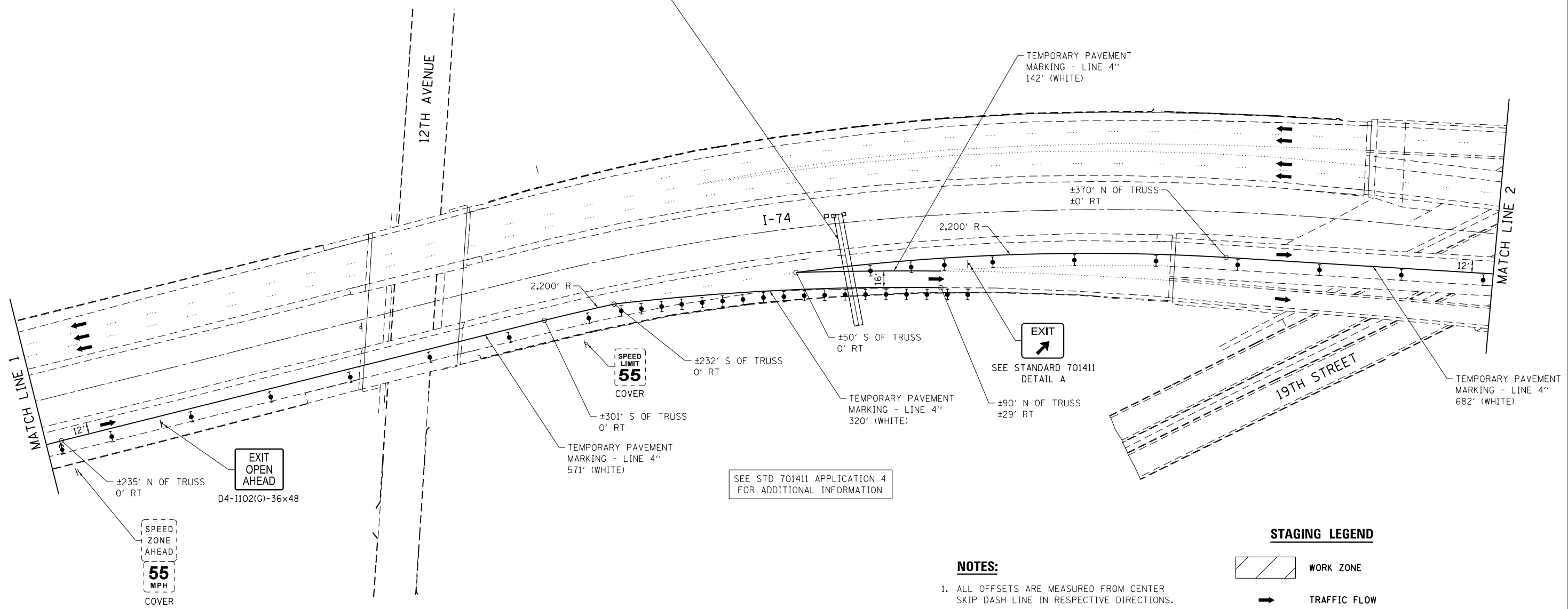
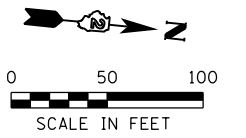

### NOTES:

- ALL OFFSETS ARE MEASURED FROM CENTER SKIP DASH LINE IN RESPECTIVE DIRECTIONS.
- THE CONTRACTOR SHALL PLACE CHECK BARRICADES AS NOTED ON HWY STD 701401.
- BARRIER WALL OFFSETS ARE MEASURED TO THE CONSTRUCTION SIDE OF BARRIER WALL.

### STAGING LEGEND

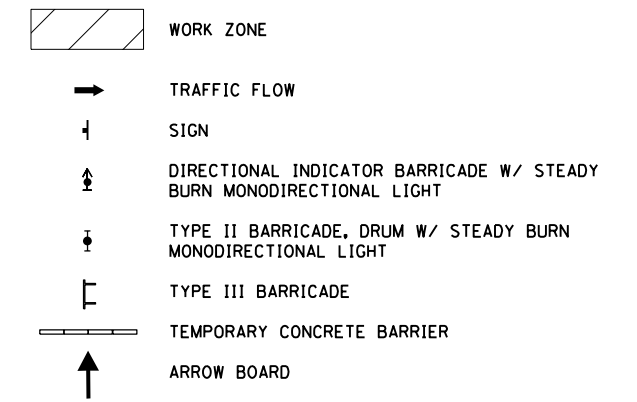

FILE NAME = S:\Projects\2012\JOBS\12-92-09\PTB 164 11 02 1-74 Bridge Repairs-Traffic Control Plans\CADD Sheets\0264H83-sht-Staging-1A02.dgn  
 MODEL = Default  
 PLOT DRIVER = 12-92-09\_PDF.plt



USER NAME = twalker	DESIGNED - MTM	REVISED -
FILE NAME = D264H83-sht-Staging-1A02.dgn	DRAWN - RG	REVISED -
PLOT SCALE = 100.0000' / 1in.	CHECKED - MCV	REVISED -
PLOT DATE = 8/7/2015	DATE - 7/31/2015	REVISED -

**STATE OF ILLINOIS  
DEPARTMENT OF TRANSPORTATION**

**I-74 STAGING PLAN  
STAGE 1A**

SCALE: SHEET NO. 2 OF 10 SHEETS STA TO STA



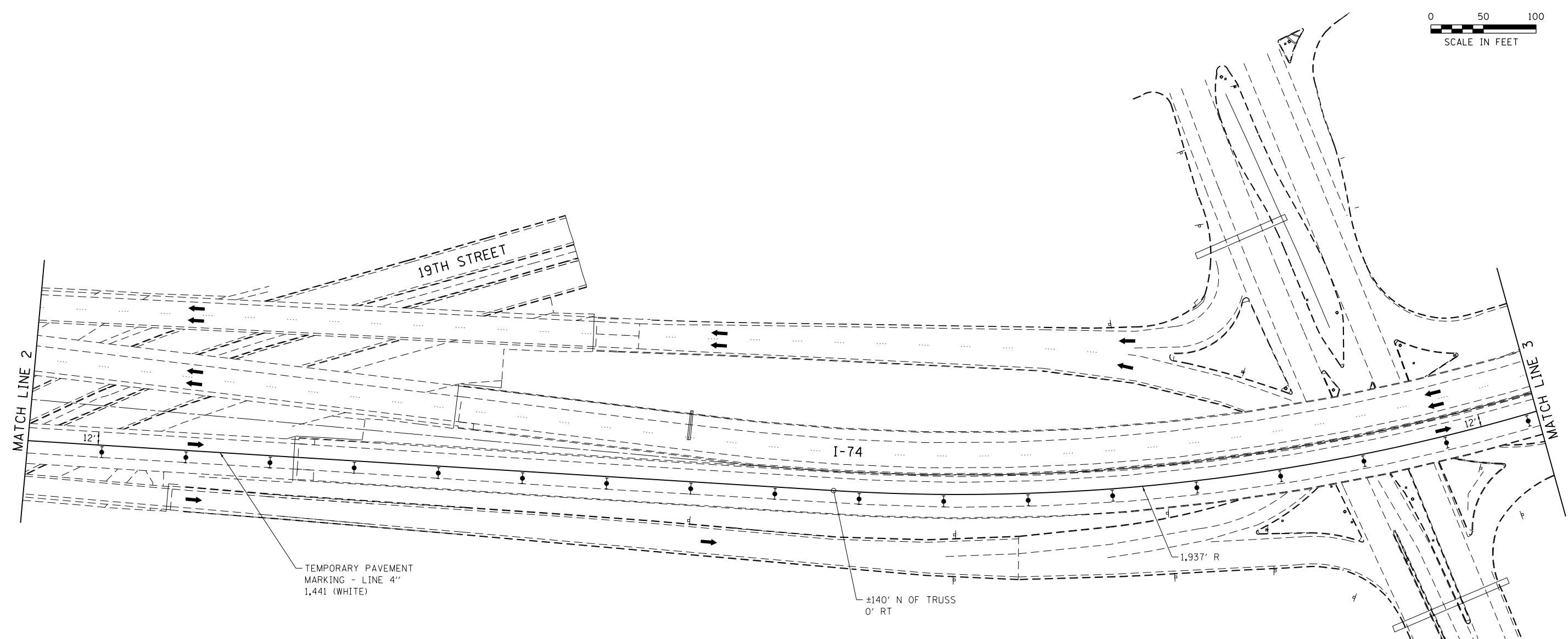
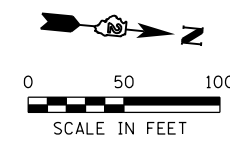





F.A.I. RTE.	SECTION	COUNTY	TOTAL SHEETS	SHEET NO.
74	(81-IHVB & 81-IHVB-1)M-3	ROCK ISLAND	69	15
CONTRACT No. 64H83			ILLINOIS FED. AID PROJECT	

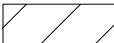

**NOTES:**

1. ALL OFFSETS ARE MEASURED FROM CENTER SKIP DASH LINE IN RESPECTIVE DIRECTIONS.
2. THE CONTRACTOR SHALL PLACE CHECK BARRICADES AS NOTED ON HWY STD 701401.
3. BARRIER WALL OFFSETS ARE MEASURED TO THE CONSTRUCTION SIDE OF BARRIER WALL.

**STAGING LEGEND**

-  WORK ZONE
-  TRAFFIC FLOW
-  SIGN
-  DIRECTIONAL INDICATOR BARRICADE W/ STEADY BURN MONODIRECTIONAL LIGHT
-  TYPE II BARRICADE, DRUM W/ STEADY BURN MONODIRECTIONAL LIGHT
-  TYPE III BARRICADE
-  TEMPORARY CONCRETE BARRIER
-  ARROW BOARD

FILE NAME = S:\Projects\2012\JOBS\12-92-09\PTB 164 11 02 1-74 Bridge Repairs-Traffic Control Plans\CADD Sheets\0264H83-sht-Staging-1A03.dgn  
 MODEL = Default  
 PLOT DRIVER = 12-92-09\_PDF.plt



USER NAME = twalker	DESIGNED - MTM	REVISED -
FILE NAME = 0264H83-sht-Staging-1A03.dgn	DRAWN - RG	REVISED -
PLOT SCALE = 100.0000' / in.	CHECKED - MCV	REVISED -
PLOT DATE = 8/7/2015	DATE - 7/31/2015	REVISED -

**STATE OF ILLINOIS**  
**DEPARTMENT OF TRANSPORTATION**

<b>I-74 STAGING PLAN</b>	
<b>STAGE 1A</b>	
SCALE:	STA TO STA
SHEET NO. 3 OF 10 SHEETS	

F.A.I. RTE.	SECTION	COUNTY	TOTAL SHEETS	SHEET NO.
74	181-IHVB & 81-IHVB-1JM-3	ROCK ISLAND	69	16
CONTRACT No. 64H83				
ILLINOIS FED. AID PROJECT				



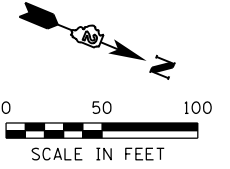

**NOTES:**

1. ALL OFFSETS ARE MEASURED FROM CENTER SKIP DASH LINE IN RESPECTIVE DIRECTIONS.
2. THE CONTRACTOR SHALL PLACE CHECK BARRICADES AS NOTED ON HWY STD 701401.
3. BARRIER WALL OFFSETS ARE MEASURED TO THE CONSTRUCTION SIDE OF BARRIER WALL.

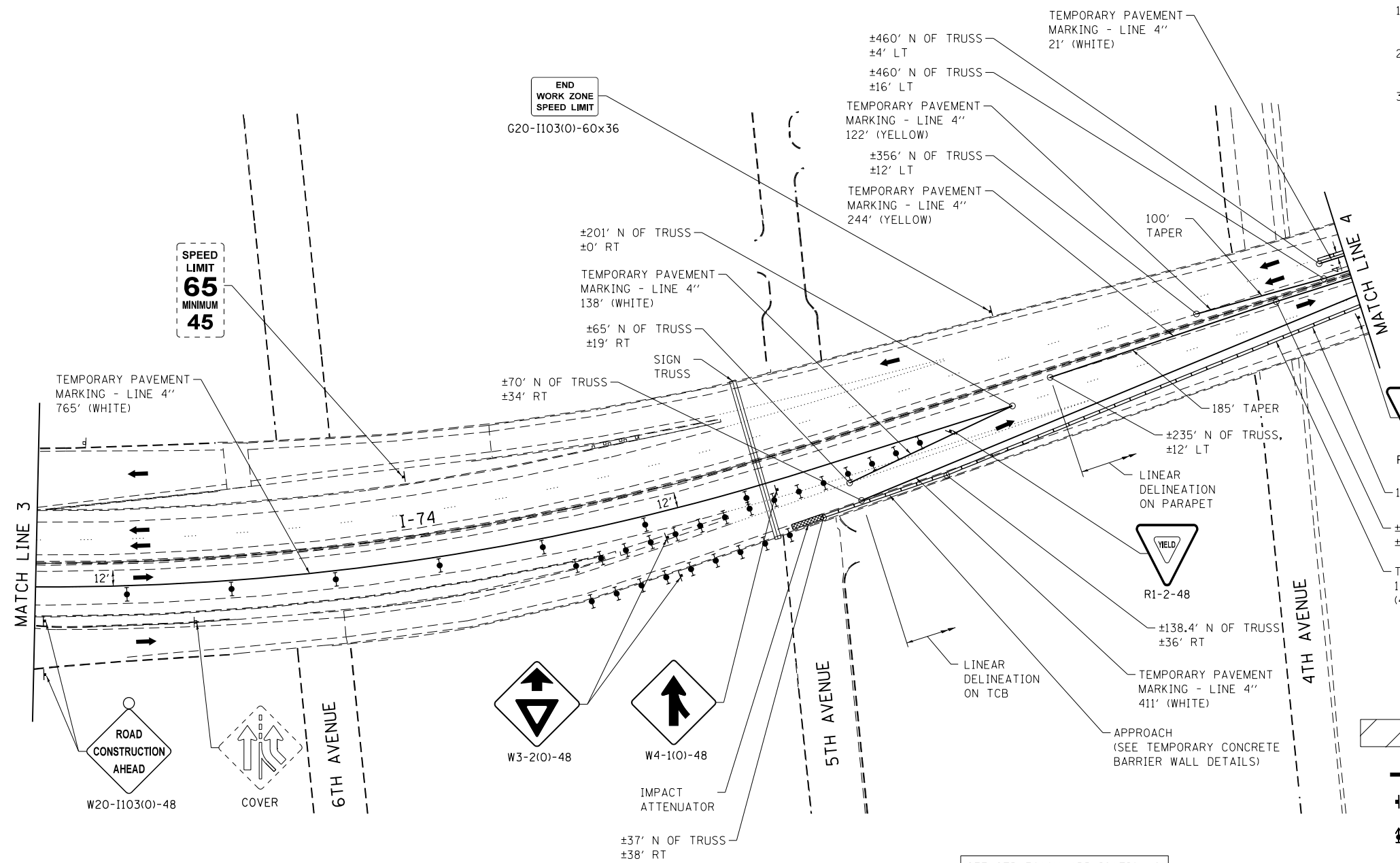

**STAGING LEGEND**

- WORK ZONE
- TRAFFIC FLOW
- SIGN
- DIRECTIONAL INDICATOR BARRICADE W/ STEADY BURN MONODIRECTIONAL LIGHT
- TYPE II BARRICADE, DRUM W/ STEADY BURN MONODIRECTIONAL LIGHT
- TYPE III BARRICADE
- TEMPORARY CONCRETE BARRIER
- ARROW BOARD

SEE STD 701411 APPLICATION 2 FOR ADDITIONAL INFORMATION

FILE NAME = S:\Projects\2012\JOBS\12-92-09\PTB 164 11 02 1-74 Bridge Repairs-Traffic Control Plans\CADD\Sheet\0264H83-sht-Staging-1A04.dgn  
 MODEL = Default  
 PLOT DRIVER = 12-92-09\_PDF.plt



USER NAME = twalker	DESIGNED - MTM	REVISED -
FILE NAME = 0264H83-sht-Staging-1A04.dgn	DRAWN - RG	REVISED -
PLOT SCALE = 100.0000' / 1in.	CHECKED - MCV	REVISED -
PLOT DATE = 8/7/2015	DATE - 7/31/2015	REVISED -

**STATE OF ILLINOIS  
DEPARTMENT OF TRANSPORTATION**

<b>I-74 STAGING PLAN STAGE 1A</b>	
SCALE:	SHEET NO. 4 OF 10 SHEETS STA TO STA

F.A.I. R.T.E.	SECTION	COUNTY	TOTAL SHEETS	SHEET NO.
74	(81-IHVB & 81-IHVB-1)M-3	ROCK ISLAND	69	17
CONTRACT No. 64H83				
ILLINOIS FED. AID PROJECT				

FILE NAME = S:\Projects\2012 Jobs\12-02-09 PTB 164 11 02 1-74 Bridge Repairs-Traffic Control Plans\CADD Sheets\0264H83-sht-Staging-1A05.dgn  
 MODEL = Default  
 PLOT DRIVER = 12-02-09\_PDF.plt

EXIT 2  
**7th Ave**  
 NEXT RIGHT

EXIT 2  
**i wireless Center**  
**John Deere Pavilion**  
**Riverfront**

EXIT 1  
**River**  
**RAMP CLOSED**  
**RAMP 20 MPH**

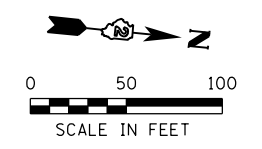
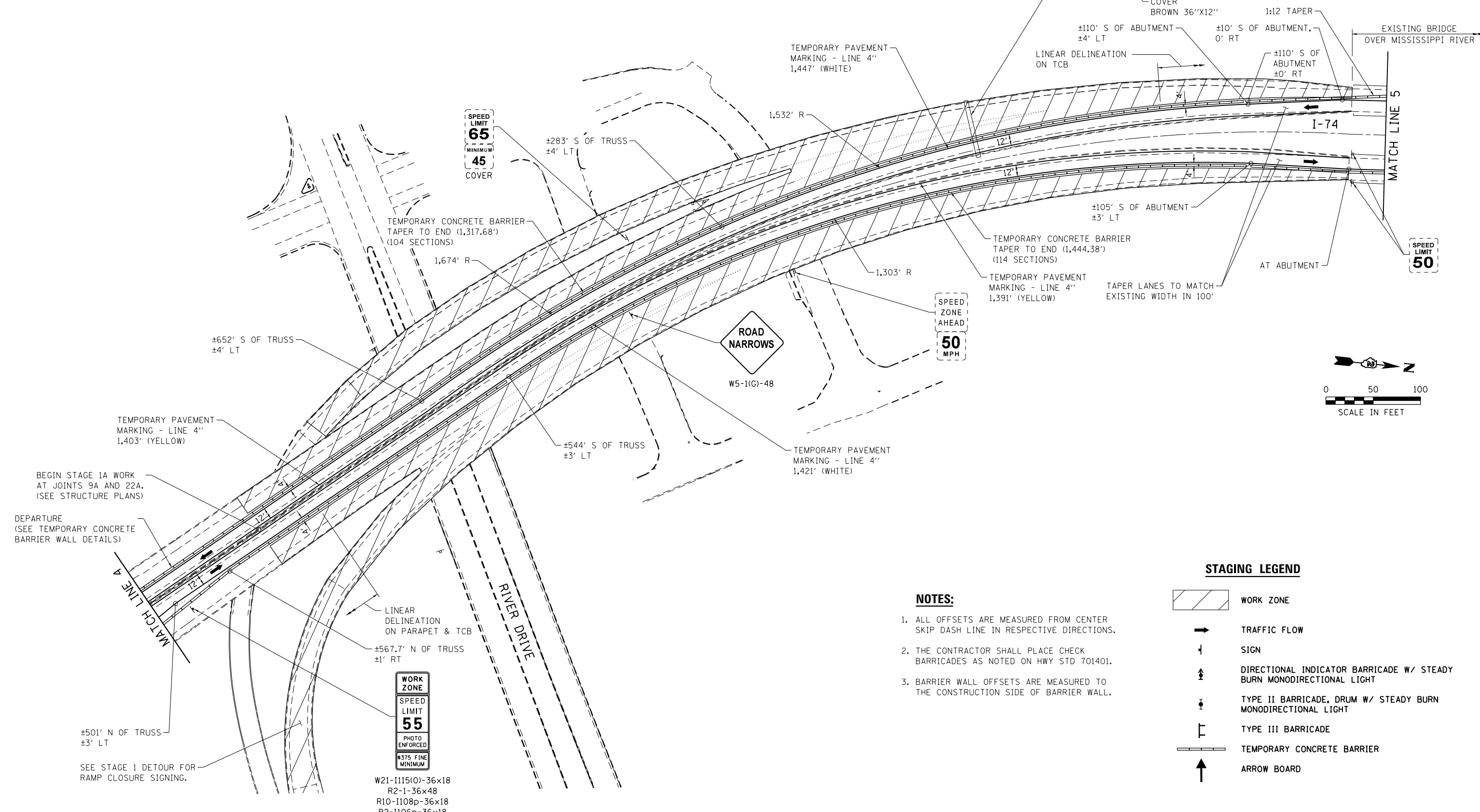

**NOTES:**

1. ALL OFFSETS ARE MEASURED FROM CENTER SKIP DASH LINE IN RESPECTIVE DIRECTIONS.
2. THE CONTRACTOR SHALL PLACE CHECK BARRICADES AS NOTED ON HWY STD 701401.
3. BARRIER WALL OFFSETS ARE MEASURED TO THE CONSTRUCTION SIDE OF BARRIER WALL.

**STAGING LEGEND**

- WORK ZONE
- TRAFFIC FLOW
- SIGN
- DIRECTIONAL INDICATOR BARRICADE W/ STEADY BURN MONODIRECTIONAL LIGHT
- TYPE II BARRICADE, DRUM W/ STEADY BURN MONODIRECTIONAL LIGHT
- TYPE III BARRICADE
- TEMPORARY CONCRETE BARRIER
- ARROW BOARD



USER NAME = twalker	DESIGNED - MTM	REVISED -
FILE NAME = 0264H83-sht-Staging-1A05.dgn	DRAWN - RG	REVISED -
PLOT SCALE = 100.0000' / 1in.	CHECKED - MCV	REVISED -
PLOT DATE = 8/7/2015	DATE - 7/31/2015	REVISED -

**STATE OF ILLINOIS**  
**DEPARTMENT OF TRANSPORTATION**

**I-74 STAGING PLAN**  
**STAGE 1A**

SCALE: SHEET NO. 5 OF 10 SHEETS STA TO STA

F.A.I. RE.	SECTION	COUNTY	TOTAL SHEETS	SHEET NO.
74	(81-1HVB & 81-1HVB-1)M-3	ROCK ISLAND	69	18
CONTRACT No. 64H83				
ILLINOIS FED. AID PROJECT				

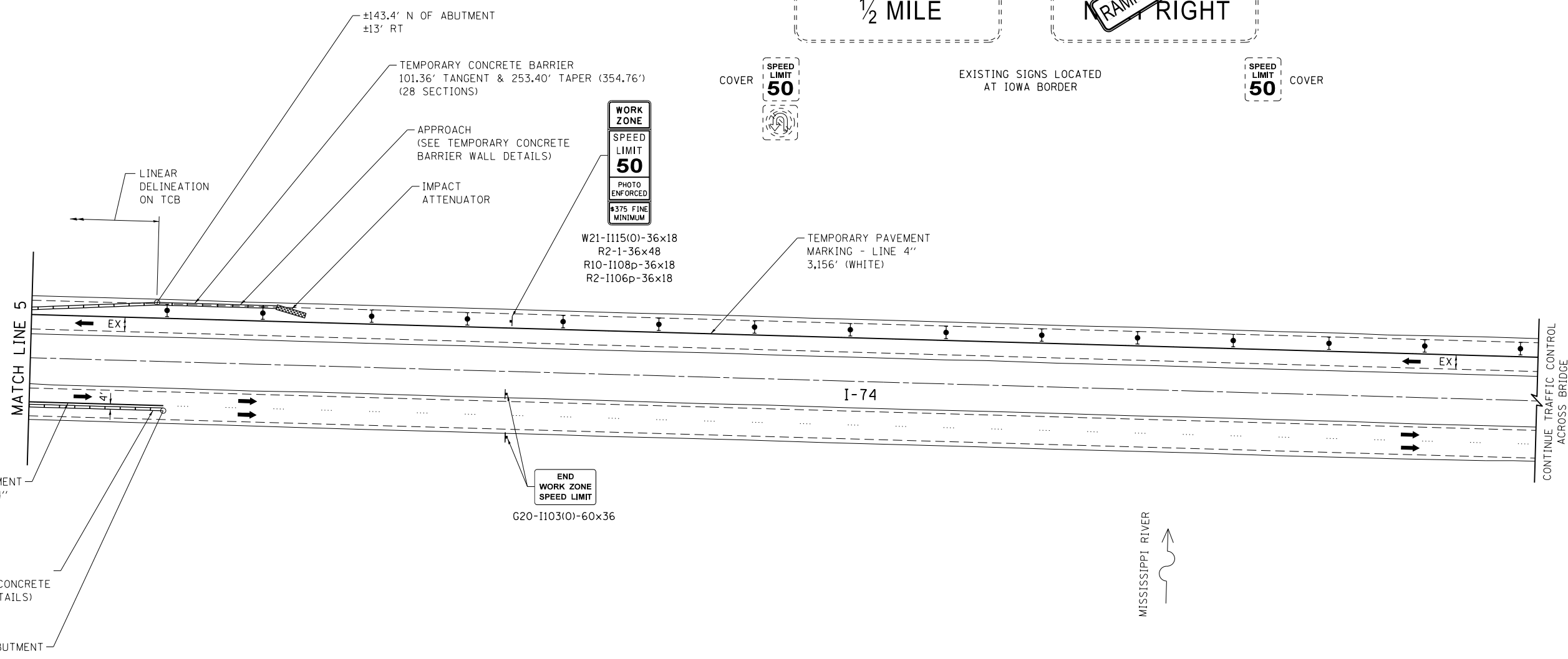
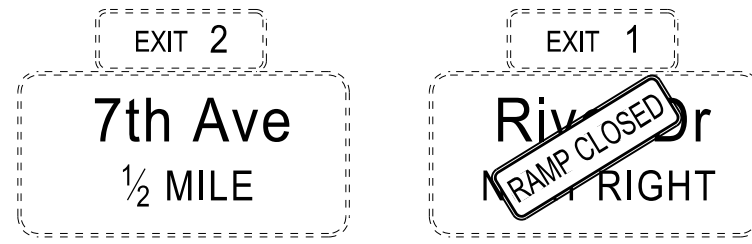
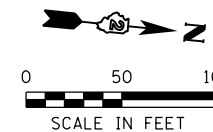

**NOTES:**

1. ALL OFFSETS ARE MEASURED FROM CENTER SKIP DASH LINE IN RESPECTIVE DIRECTIONS.
2. THE CONTRACTOR SHALL PLACE CHECK BARRICADES AS NOTED ON HWY STD 701401.
3. BARRIER WALL OFFSETS ARE MEASURED TO THE CONSTRUCTION SIDE OF BARRIER WALL.

**STAGING LEGEND**

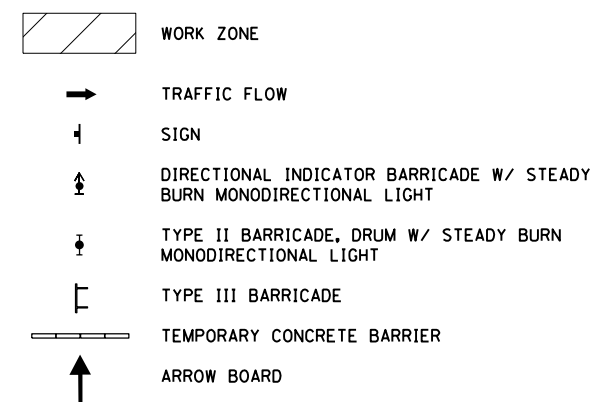

FILE NAME = S:\Projects\2012\JOBS\12-92-09\PTB 164 11 02 1-74 Bridge Repairs-Traffic Control Plans\CADD Sheets\0264H83-sht-Staging-1A06.dgn  
 MODEL = Default  
 PLOT DRIVER = 12-92-09\_PDF.plt



USER NAME = twalker	DESIGNED - MTM	REVISED -
FILE NAME = 0264H83-sht-Staging-1A06.dgn	DRAWN - RG	REVISED -
PLOT SCALE = 100.0000' / in.	CHECKED - MCV	REVISED -
PLOT DATE = 8/7/2015	DATE - 7/31/2015	REVISED -

**STATE OF ILLINOIS**  
**DEPARTMENT OF TRANSPORTATION**

<b>I-74 STAGING PLAN</b>	
<b>STAGE 1A</b>	
SCALE:	STA TO STA

F.A.I. RTE.	SECTION	COUNTY	TOTAL SHEETS	SHEET NO.
74	(81-IHVB & 81-IHVB-1)M-3	ROCK ISLAND	69	19
CONTRACT No. 64H83				
ILLINOIS FED. AID PROJECT				

FILE NAME = S:\Projects\2012\JOBS\12-92-09\PTB 164 11 02 1-74 Bridge Repairs-Traffic Control Plans\CADD Sheets\0264H83-sht-Staging-1A07.dgn  
 MODEL = Default  
 PLOT DRIVER = 12-92-09\_PDF.plt

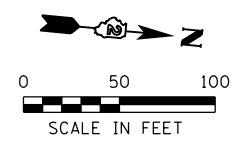
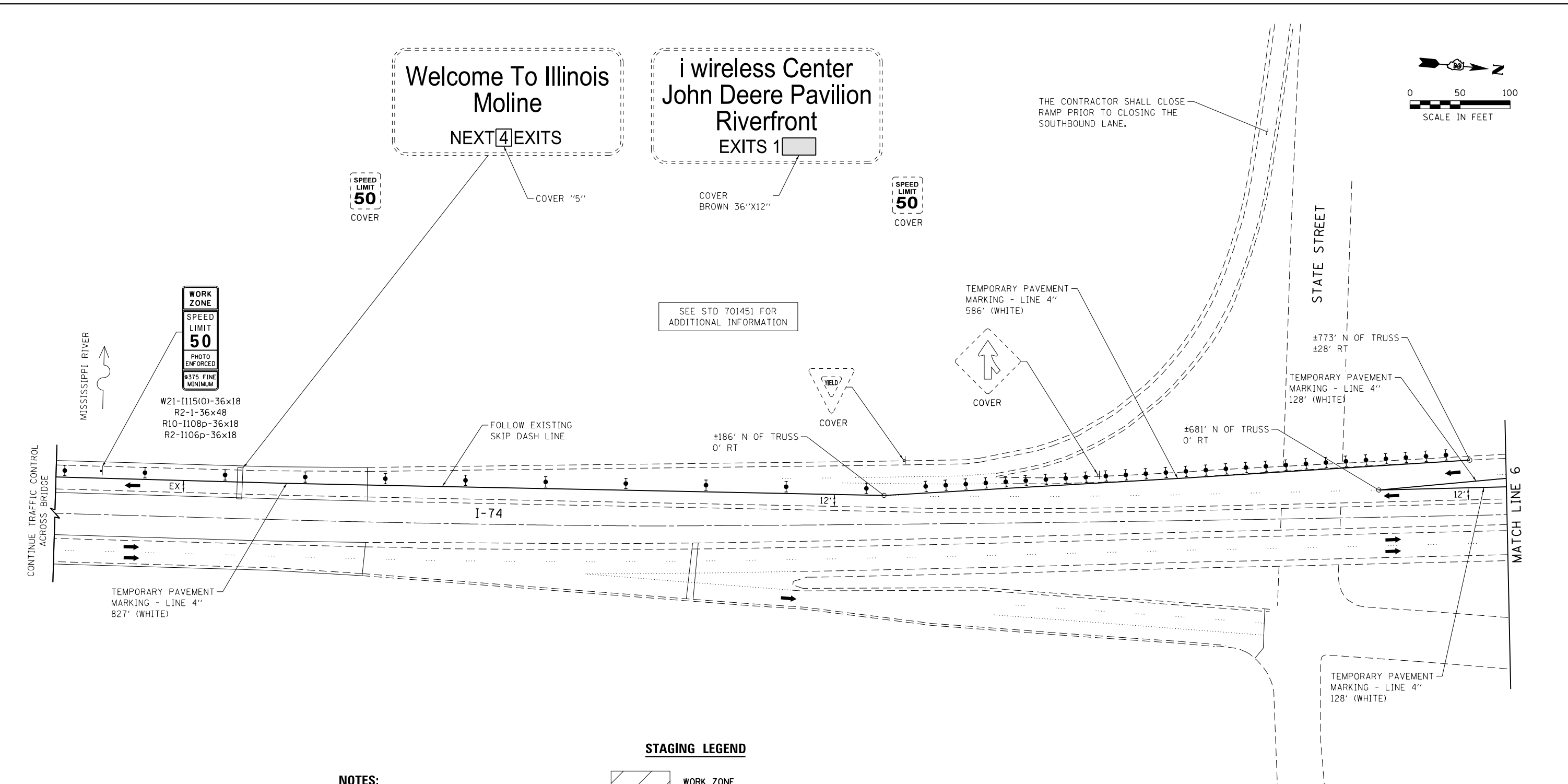

- NOTES:**
1. ALL OFFSETS ARE MEASURED FROM CENTER SKIP DASH LINE IN RESPECTIVE DIRECTIONS.
  2. THE CONTRACTOR SHALL PLACE CHECK BARRICADES AS NOTED ON HWY STD 701401.
  3. BARRIER WALL OFFSETS ARE MEASURED TO THE CONSTRUCTION SIDE OF BARRIER WALL.

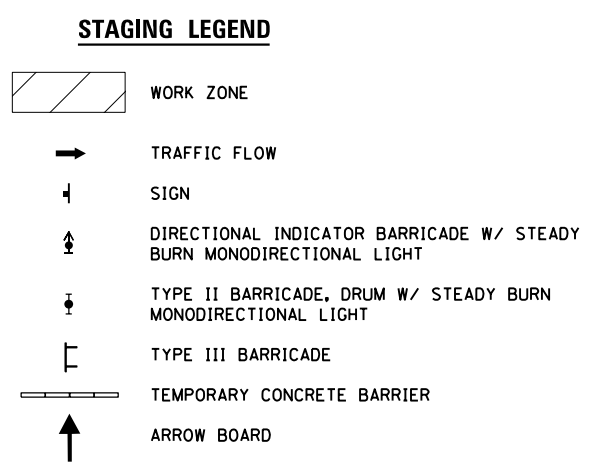

USER NAME = twalker	DESIGNED - MTM	REVISED -
FILE NAME = 0264H83-sht-Staging-1A07.dgn	DRAWN - RG	REVISED -
PLOT SCALE = 100.0000' / 1in.	CHECKED - MCV	REVISED -
PLOT DATE = 8/7/2015	DATE - 7/31/2015	REVISED -

**STATE OF ILLINOIS  
DEPARTMENT OF TRANSPORTATION**

**I-74 STAGING PLAN  
STAGE 1A**

SCALE: SHEET NO. 7 OF 10 SHEETS STA TO STA

F.A.I. RTE.	SECTION	COUNTY	TOTAL SHEETS	SHEET NO.
74	181-IHVB & 81-IHVB-1JM-3	ROCK ISLAND	69	20
CONTRACT No. 64H83				
ILLINOIS FED. AID PROJECT				

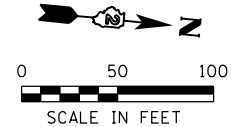

SEE STD 701411 APPLICATION 2 FOR ADDITIONAL INFORMATION

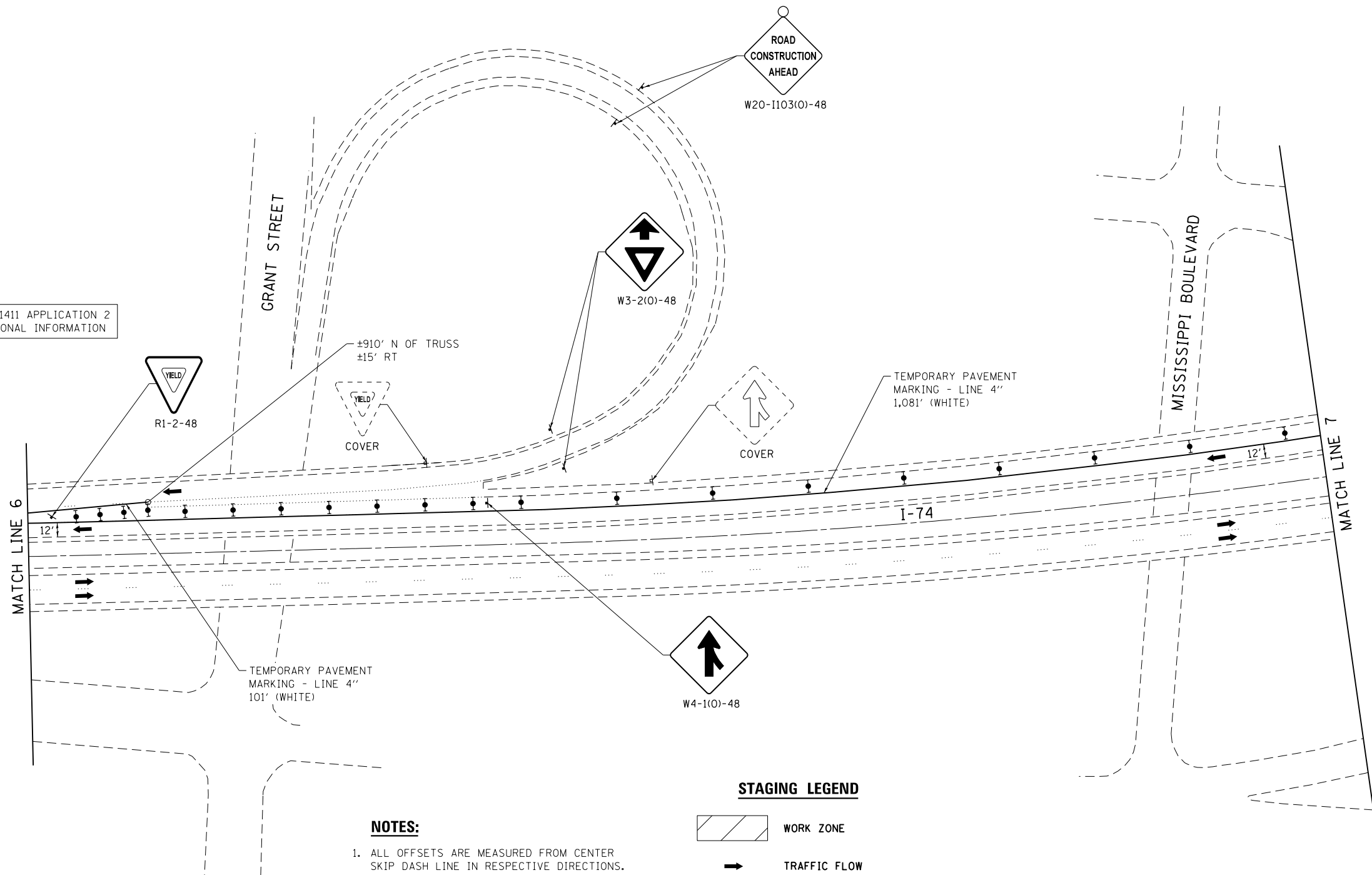

- NOTES:**
1. ALL OFFSETS ARE MEASURED FROM CENTER SKIP DASH LINE IN RESPECTIVE DIRECTIONS.
  2. THE CONTRACTOR SHALL PLACE CHECK BARRICADES AS NOTED ON HWY STD 701401.
  3. BARRIER WALL OFFSETS ARE MEASURED TO THE CONSTRUCTION SIDE OF BARRIER WALL.

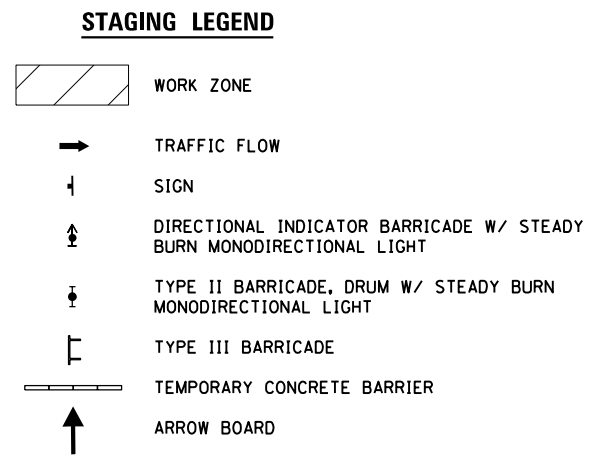

FILE NAME = S:\Projects\2012\JOBS\12-92-09\PTB 164 11 02 1-74 Bridge Repairs-Traffic Control Plans\CADD\CADD Sheets\0264H83-sht-Staging-1A08.dgn  
 MODEL = Default  
 PLOT DRIVER = 12-92-09\_PDF.plt



USER NAME = twalker	DESIGNED - MTM	REVISED -
FILE NAME = 0264H83-sht-Staging-1A08.dgn	DRAWN - RG	REVISED -
PLOT SCALE = 100.0000' / 1in.	CHECKED - MCV	REVISED -
PLOT DATE = 8/7/2015	DATE - 7/31/2015	REVISED -

**STATE OF ILLINOIS  
DEPARTMENT OF TRANSPORTATION**

<b>I-74 STAGING PLAN STAGE 1A</b>	
SCALE:	TO STA
SHEET NO. 8 OF 10 SHEETS	STA

F.A.I. RTE.	SECTION	COUNTY	TOTAL SHEETS	SHEET NO.
74	181-IHVB & 81-IHVB-1M-3	ROCK ISLAND	69	21
CONTRACT No. 64H83				
ILLINOIS FED. AID PROJECT				

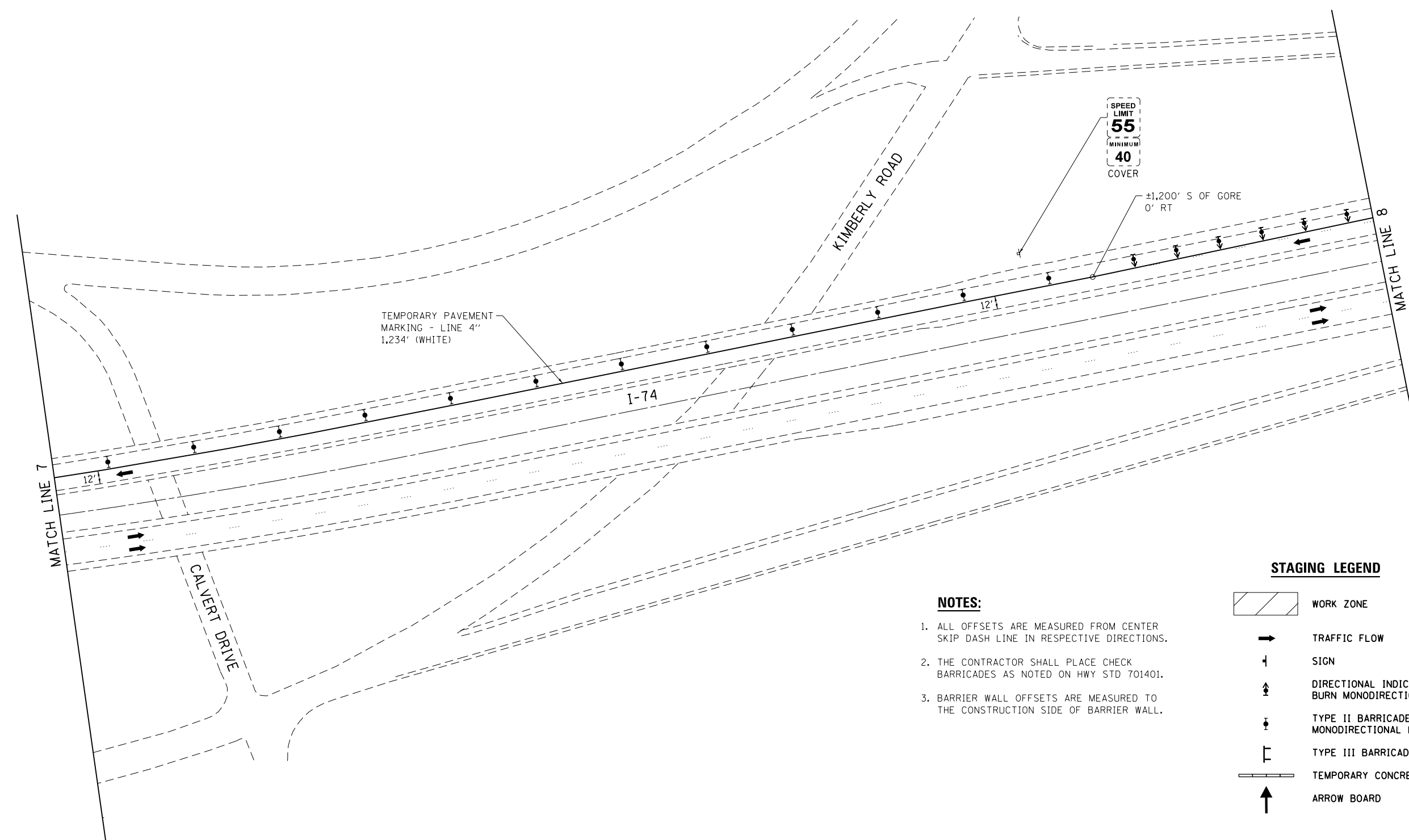
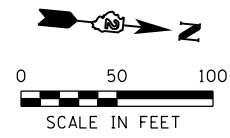

SPEED LIMIT  
**55**  
MINIMUM  
**40**  
COVER

TEMPORARY PAVEMENT  
MARKING - LINE 4"  
1,234' (WHITE)

±1,200' S OF GORE  
0' RT

**NOTES:**

1. ALL OFFSETS ARE MEASURED FROM CENTER SKIP DASH LINE IN RESPECTIVE DIRECTIONS.
2. THE CONTRACTOR SHALL PLACE CHECK BARRICADES AS NOTED ON HWY STD 701401.
3. BARRIER WALL OFFSETS ARE MEASURED TO THE CONSTRUCTION SIDE OF BARRIER WALL.

**STAGING LEGEND**

- WORK ZONE
- TRAFFIC FLOW
- SIGN
- DIRECTIONAL INDICATOR BARRICADE W/ STEADY BURN MONODIRECTIONAL LIGHT
- TYPE II BARRICADE, DRUM W/ STEADY BURN MONODIRECTIONAL LIGHT
- TYPE III BARRICADE
- TEMPORARY CONCRETE BARRIER
- ARROW BOARD

FILE NAME = S:\Projects\2012\JOBS\12-92-09\PTB 164 11 02 1-74 Bridge Repairs-Traffic Control Plans\CADD Sheets\0264H83-sht-Staging-1A09.dgn  
 MODEL = Default  
 PLOT DRIVER = 12-92-09\_PDF.plt



USER NAME = twalker	DESIGNED - MTM	REVISED -
FILE NAME = 0264H83-sht-Staging-1A09.dgn	DRAWN - RG	REVISED -
PLOT SCALE = 100.0000' / in.	CHECKED - MCV	REVISED -
PLOT DATE = 8/7/2015	DATE - 7/31/2015	REVISED -

**STATE OF ILLINOIS  
DEPARTMENT OF TRANSPORTATION**

**I-74 STAGING PLAN  
STAGE 1A**

SCALE: SHEET NO. 9 OF 10 SHEETS STA TO STA

F.A.I. RTE.	SECTION	COUNTY	TOTAL SHEETS	SHEET NO.
74	181-IHVB & 81-IHVB-1JM-3	ROCK ISLAND	69	22
CONTRACT No. 64H83				
ILLINOIS FED. AID PROJECT				

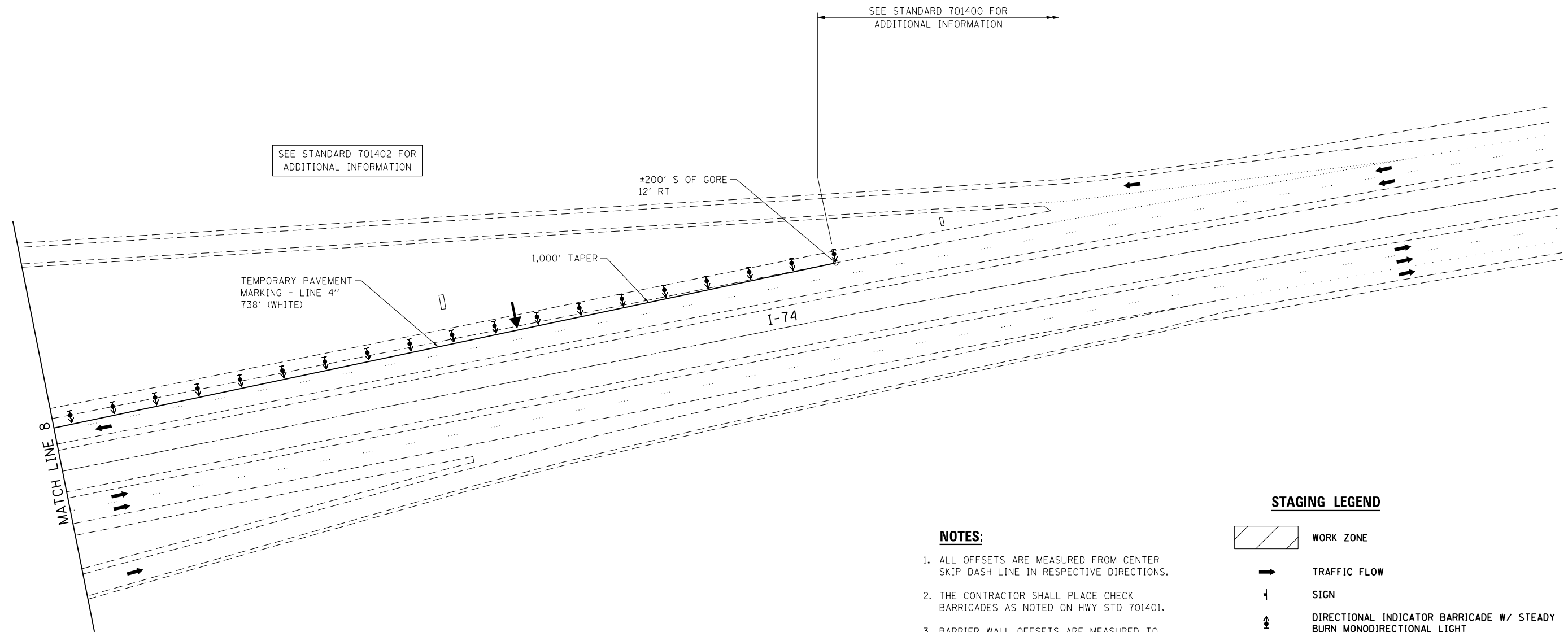
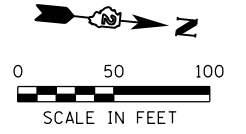

SEE STANDARD 701402 FOR  
ADDITIONAL INFORMATION

SEE STANDARD 701400 FOR  
ADDITIONAL INFORMATION

±200' S OF GORE  
12' RT









1,000' TAPER

TEMPORARY PAVEMENT  
MARKING - LINE 4"  
738' (WHITE)

I-74

MATCH LINE 8

**STAGING LEGEND**

-  WORK ZONE
-  TRAFFIC FLOW
-  SIGN
-  DIRECTIONAL INDICATOR BARRICADE W/ STEADY BURN MONODIRECTIONAL LIGHT
-  TYPE II BARRICADE, DRUM W/ STEADY BURN MONODIRECTIONAL LIGHT
-  TYPE III BARRICADE
-  TEMPORARY CONCRETE BARRIER
-  ARROW BOARD

**NOTES:**

1. ALL OFFSETS ARE MEASURED FROM CENTER SKIP DASH LINE IN RESPECTIVE DIRECTIONS.
2. THE CONTRACTOR SHALL PLACE CHECK BARRICADES AS NOTED ON HWY STD 701401.
3. BARRIER WALL OFFSETS ARE MEASURED TO THE CONSTRUCTION SIDE OF BARRIER WALL.

FILE NAME = S:\Projects\2012\JOBS\12-92-09\PTB 164 11 02 I-74 Bridge Repairs-Traffic Control Plans\CADD Sheets\0264H83-sht-Staging-1A10.dgn  
 MODEL = Default  
 PLOT DRIVER = 12-92-09\_PDF.plt



USER NAME = twalker	DESIGNED - MTM	REVISED -
FILE NAME = 0264H83-sht-Staging-1A10.dgn	DRAWN - RG	REVISED -
PLOT SCALE = 100.0000' / in.	CHECKED - MCV	REVISED -
PLOT DATE = 8/7/2015	DATE - 7/31/2015	REVISED -







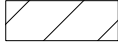

**STATE OF ILLINOIS  
DEPARTMENT OF TRANSPORTATION**

**I-74 STAGING PLAN  
STAGE 1A**

SCALE: SHEET NO. 10 OF 10 SHEETS STA TO STA

F.A.I. RTE.	SECTION	COUNTY	TOTAL SHEETS	SHEET NO.
74	(81-IHVB & 81-IHVB-1)M-3	ROCK ISLAND	69	23
CONTRACT No. 64H83				
ILLINOIS FED. AID PROJECT				

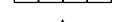
**STAGING LEGEND**

-  WORK ZONE
-  TRAFFIC FLOW
-  SIGN
-  DIRECTIONAL INDICATOR BARRICADE W/ STEADY BURN MONODIRECTIONAL LIGHT
-  TYPE II BARRICADE, DRUM W/ STEADY BURN MONODIRECTIONAL LIGHT
-  TYPE III BARRICADE
-  TEMPORARY CONCRETE BARRIER
-  ARROW BOARD

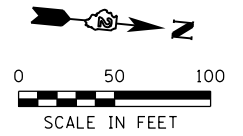

**NOTES:**

1. ALL OFFSETS ARE MEASURED FROM CENTER SKIP DASH LINE IN RESPECTIVE DIRECTIONS.
2. THE CONTRACTOR SHALL PLACE CHECK BARRICADES AS NOTED ON HWY STD 701401.
3. BARRIER WALL OFFSETS ARE MEASURED TO THE CONSTRUCTION SIDE OF BARRIER WALL.

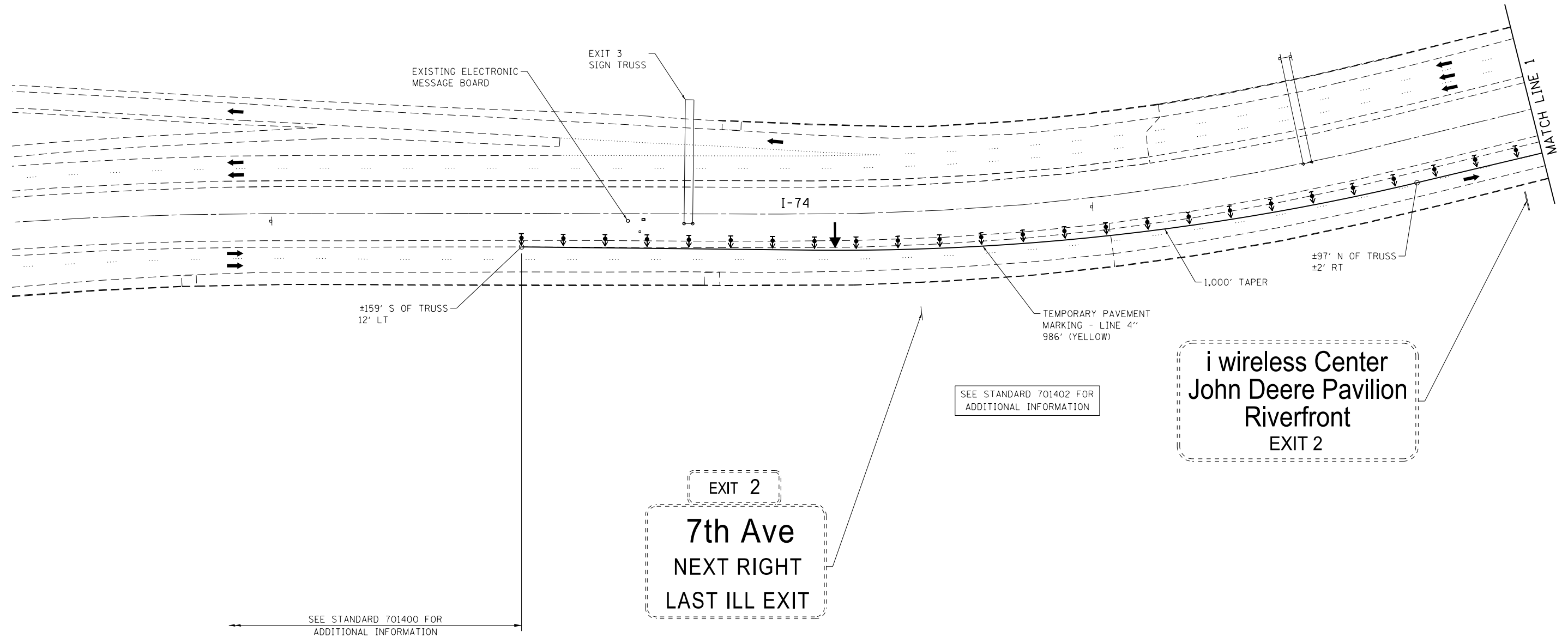

**EXIT 2**  
**7th Ave**  
**NEXT RIGHT**  
**LAST ILL EXIT**

**i wireless Center**  
**John Deere Pavilion**  
**Riverfront**  
**EXIT 2**

SEE STANDARD 701402 FOR ADDITIONAL INFORMATION

SEE STANDARD 701400 FOR ADDITIONAL INFORMATION

FILE NAME = S:\Projects\2012\JOBS\12-92-09\PTB 164 11 02 1-74 Bridge Repairs-Traffic Control Plans\CADD Sheets\0264H83-sht-Staging-1B01.dgn  
 MODEL = Default  
 PLOT DRIVER = 12-92-091.PDF.pltcf9



USER NAME = twalker	DESIGNED - MTM	REVISED -	REVISED -
FILE NAME = 0264H83-sht-Staging-1B01.dgn	DRAWN - RG	REVISED -	REVISED -
PLOT SCALE = 100.0000' / 1in.	CHECKED - MCV	REVISED -	REVISED -
PLOT DATE = 8/7/2015	DATE - 7/31/2015	REVISED -	REVISED -

**STATE OF ILLINOIS**  
**DEPARTMENT OF TRANSPORTATION**

**I-74 STAGING PLAN**  
**STAGE 1B**

SCALE:      SHEET NO. 1 OF 10 SHEETS      STA      TO STA

F.A.I. RTE.	SECTION	COUNTY	TOTAL SHEETS	SHEET NO.
74	181-1HVB & 81-1HVB-1JM-3	ROCK ISLAND	69	24
CONTRACT No. 64H83				
ILLINOIS FED. AID PROJECT				



### Davenport - Bettendorf EXITS

- Grant St - State St 1
- Middle Rd - Locust St 2
- Kimberly Rd - Spruce Hills Dr 3
- 53rd St 4

EXIT 2

7th Avenue

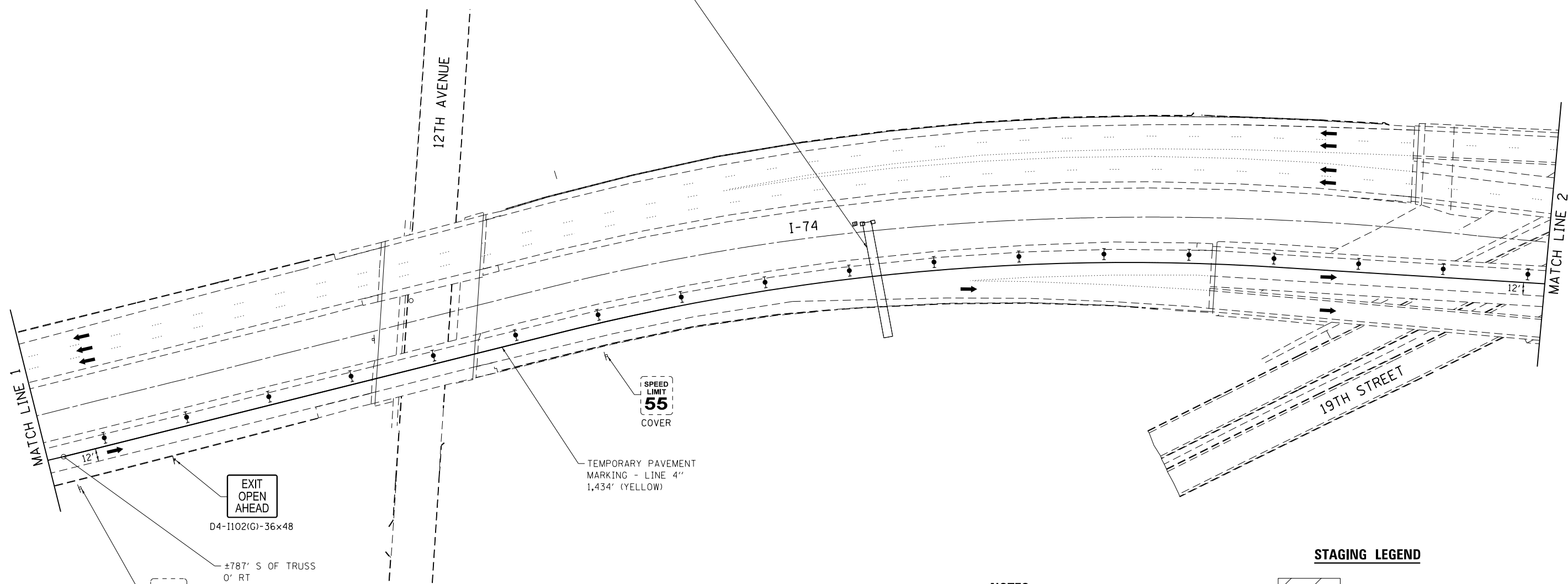
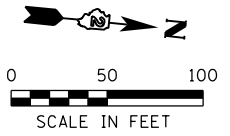

#### STAGING LEGEND

- WORK ZONE
- TRAFFIC FLOW
- SIGN
- DIRECTIONAL INDICATOR BARRICADE W/ STEADY BURN MONODIRECTIONAL LIGHT
- TYPE II BARRICADE, DRUM W/ STEADY BURN MONODIRECTIONAL LIGHT
- TYPE III BARRICADE
- TEMPORARY CONCRETE BARRIER
- ARROW BOARD

#### NOTES:

1. ALL OFFSETS ARE MEASURED FROM CENTER SKIP DASH LINE IN RESPECTIVE DIRECTIONS.
2. THE CONTRACTOR SHALL PLACE CHECK BARRICADES AS NOTED ON HWY STD 701401.
3. BARRIER WALL OFFSETS ARE MEASURED TO THE CONSTRUCTION SIDE OF BARRIER WALL.

FILE NAME = S:\Projects\2012\JOBS\12-92-09\PTB 164 11 02 I-74 Bridge Repairs-Traffic Control Plans\CADD\CADD Sheets\0264H83-sht-Staging-1B02.dgn  
 MODEL = Default  
 PLOT DRIVER = 12-92-09\_PDF.plt



USER NAME = twalker	DESIGNED - MTM	REVISED -
FILE NAME = 0264H83-sht-Staging-1B02.dgn	DRAWN - RG	REVISED -
PLOT SCALE = 100.0000' / in.	CHECKED - MCV	REVISED -
PLOT DATE = 8/7/2015	DATE - 7/31/2015	REVISED -

**STATE OF ILLINOIS**  
**DEPARTMENT OF TRANSPORTATION**

**I-74 STAGING PLAN**  
**STAGE 1B**

SCALE: SHEET NO. 2 OF 10 SHEETS STA TO STA



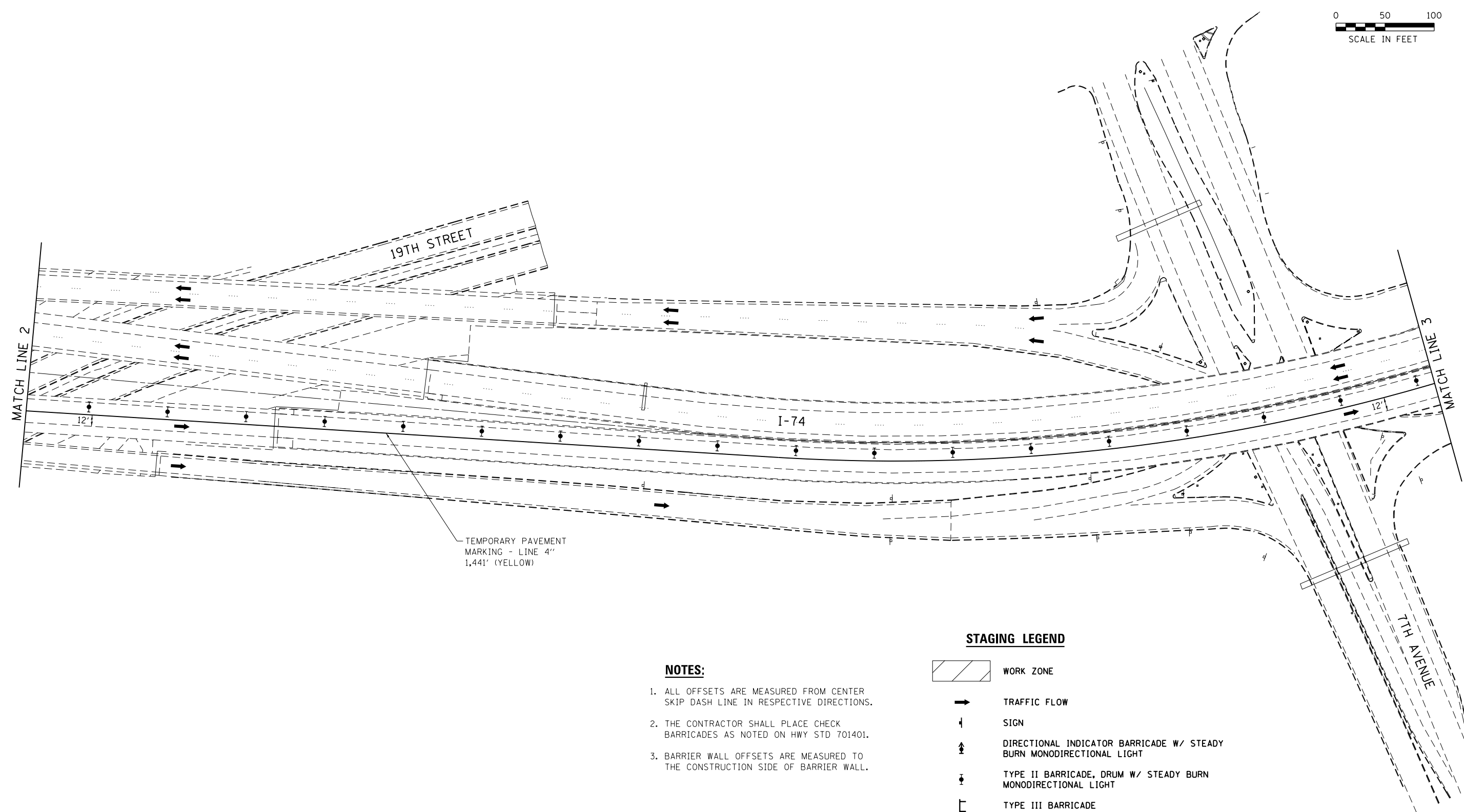
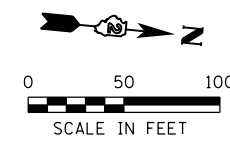





F.A.I. RTE.	SECTION	COUNTY	TOTAL SHEETS	SHEET NO.
74	181-IHVB & 81-IHVB-1JM-3	ROCK ISLAND	69	25
CONTRACT No. 64H83				
ILLINOIS FED. AID PROJECT				

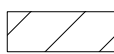

**NOTES:**

1. ALL OFFSETS ARE MEASURED FROM CENTER SKIP DASH LINE IN RESPECTIVE DIRECTIONS.
2. THE CONTRACTOR SHALL PLACE CHECK BARRICADES AS NOTED ON HWY STD 701401.
3. BARRIER WALL OFFSETS ARE MEASURED TO THE CONSTRUCTION SIDE OF BARRIER WALL.

**STAGING LEGEND**

-  WORK ZONE
-  TRAFFIC FLOW
-  SIGN
-  DIRECTIONAL INDICATOR BARRICADE W/ STEADY BURN MONODIRECTIONAL LIGHT
-  TYPE II BARRICADE, DRUM W/ STEADY BURN MONODIRECTIONAL LIGHT
-  TYPE III BARRICADE
-  TEMPORARY CONCRETE BARRIER
-  ARROW BOARD

FILE NAME = S:\Projects\2012\JOBS\12-92-09\PTB 164 11 02 1-74 Bridge Repairs-Traffic Control Plans\CADD Sheets\0264H83-sht-Staging-1B03.dgn  
 MODEL = Default  
 PLOT DRIVER = 12-92-09\_PDF.plt

 <b>QUIGG ENGINEERING INC</b>	USER NAME = twalker	DESIGNED - MTM	REVISED -
	FILE NAME = 0264H83-sht-Staging-1B03.dgn	DRAWN - RG	REVISED -
	PLOT SCALE = 100.0000' / 1in.	CHECKED - MCV	REVISED -
	PLOT DATE = 8/7/2015	DATE - 7/31/2015	REVISED -

**STATE OF ILLINOIS**  
**DEPARTMENT OF TRANSPORTATION**

<b>I-74 STAGING PLAN</b>	
<b>STAGE 1B</b>	
SCALE:	STA TO STA
SHEET NO. 3	OF 10 SHEETS

F.A.I. RTE.	SECTION	COUNTY	TOTAL SHEETS	SHEET NO.
74	181-IHVB & 81-IHVB-1JM-3	ROCK ISLAND	69	26
CONTRACT No. 64H83				
ILLINOIS FED. AID PROJECT				

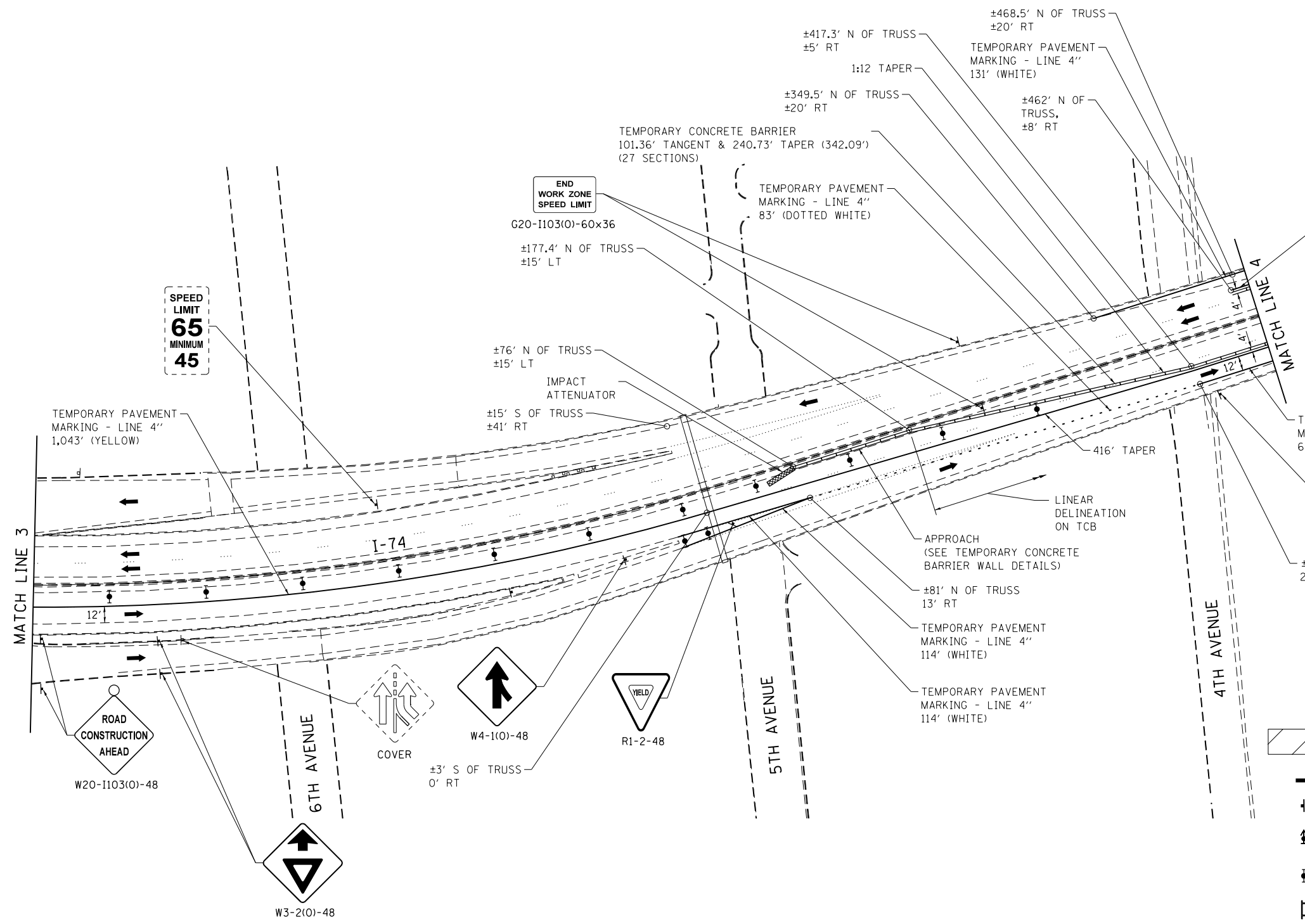
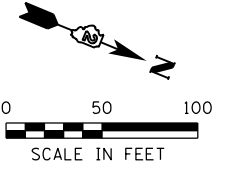

- NOTES:**
1. ALL OFFSETS ARE MEASURED FROM CENTER SKIP DASH LINE IN RESPECTIVE DIRECTIONS.
  2. THE CONTRACTOR SHALL PLACE CHECK BARRICADES AS NOTED ON HWY STD 701401.
  3. BARRIER WALL OFFSETS ARE MEASURED TO THE CONSTRUCTION SIDE OF BARRIER WALL.

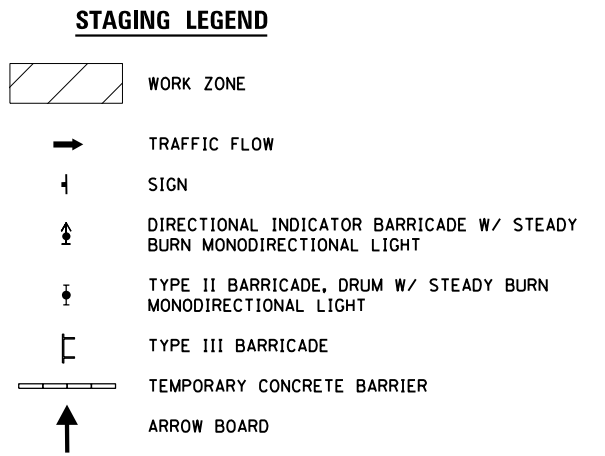

FILE NAME = S:\Projects\2012\JOBS\12-92-09\PTB 164 11 02 1-74 Bridge Repairs-Traffic Control Plans\CADD Sheets\0264H83-sht-Staging-1B04.dgn  
 MODEL = Default  
 PLOT DRIVER = 12-92-09\_PDF.plt



USER NAME = twalker	DESIGNED - MTM	REVISED -
FILE NAME = 0264H83-sht-Staging-1B04.dgn	DRAWN - RG	REVISED -
PLOT SCALE = 100.0000' / 1in.	CHECKED - MCV	REVISED -
PLOT DATE = 8/7/2015	DATE - 7/31/2015	REVISED -

**STATE OF ILLINOIS  
DEPARTMENT OF TRANSPORTATION**

<b>I-74 STAGING PLAN STAGE 1B</b>	
SCALE:	STA TO STA
SHEET NO. 4 OF 10 SHEETS	

F.A.I. RTE.	SECTION	COUNTY	TOTAL SHEETS	SHEET NO.
74	(81-IHVB & 81-IHVB-1)M-3	ROCK ISLAND	69	27
CONTRACT No. 64H83				
ILLINOIS FED. AID PROJECT				

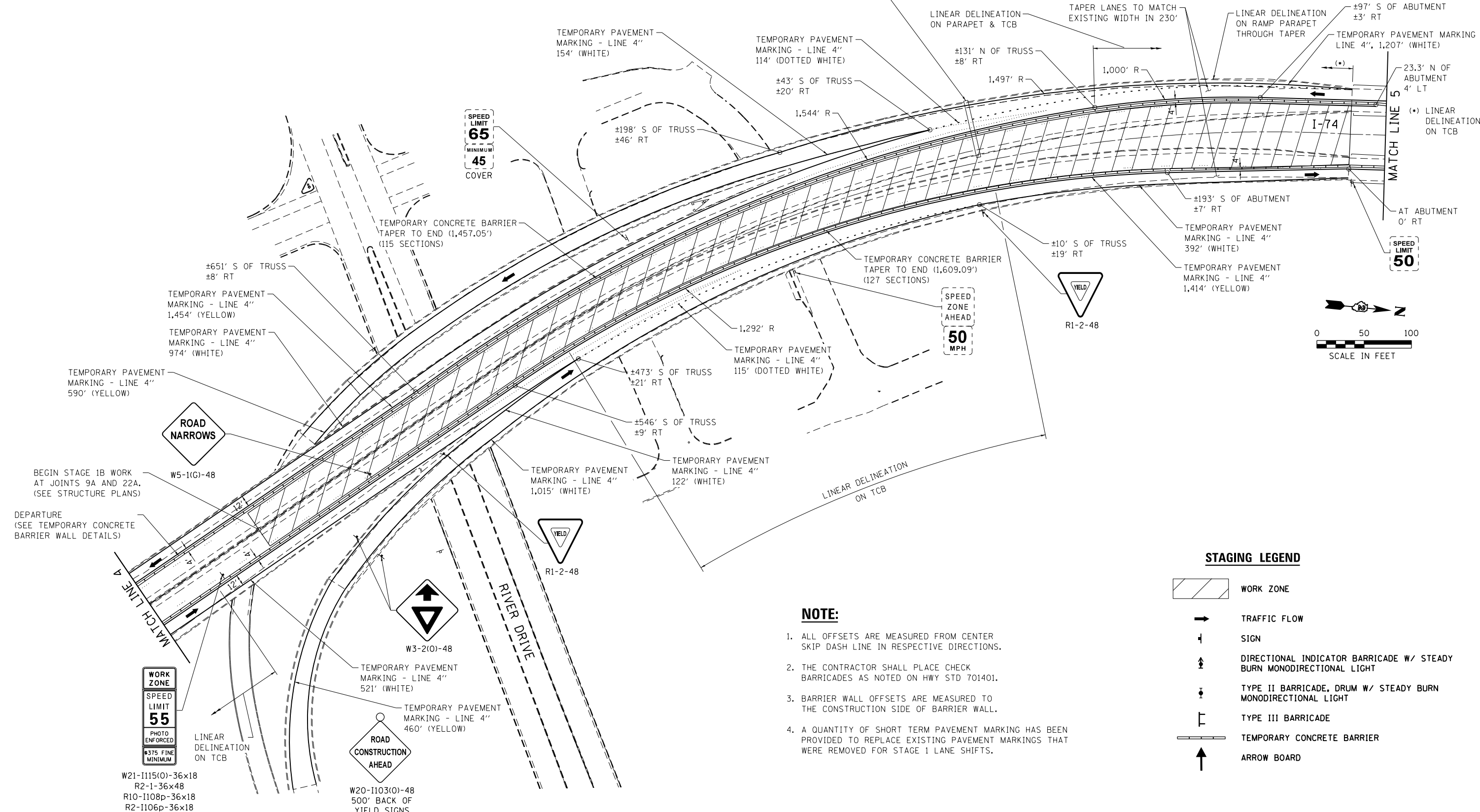

- NOTE:**
1. ALL OFFSETS ARE MEASURED FROM CENTER SKIP DASH LINE IN RESPECTIVE DIRECTIONS.
  2. THE CONTRACTOR SHALL PLACE CHECK BARRICADES AS NOTED ON HWY STD 701401.
  3. BARRIER WALL OFFSETS ARE MEASURED TO THE CONSTRUCTION SIDE OF BARRIER WALL.
  4. A QUANTITY OF SHORT TERM PAVEMENT MARKING HAS BEEN PROVIDED TO REPLACE EXISTING PAVEMENT MARKINGS THAT WERE REMOVED FOR STAGE 1 LANE SHIFTS.

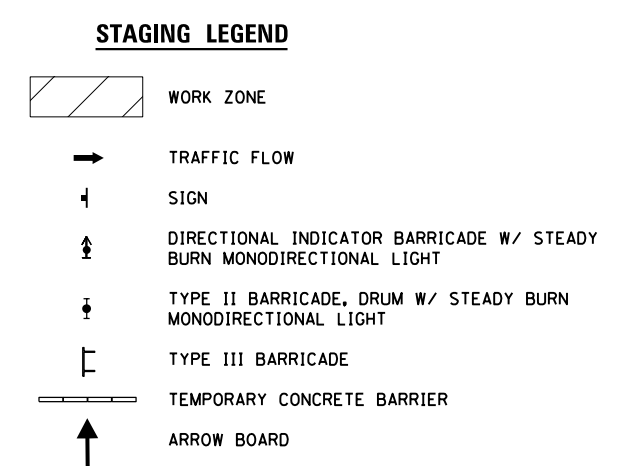

FILE NAME = S:\Projects\2012\JOBS\12-92-09\PTB 164 11 02 1-74 Bridge Repairs-Traffic Control Plans\CADD\CADD Sheets\0264H83-sht-Staging-1B05.dgn  
 MODEL = Default  
 PLOT DRIVER = 12-92-09\_PDF.plt



USER NAME = twalker	DESIGNED - MTM	REVISED -
FILE NAME = D264H83-sht-Staging-1B05.dgn	DRAWN - RG	REVISED -
PLOT SCALE = 100.0000' / 1in.	CHECKED - MCV	REVISED -
PLOT DATE = 8/7/2015	DATE - 7/31/2015	REVISED -

**STATE OF ILLINOIS  
DEPARTMENT OF TRANSPORTATION**

**I-74 STAGING PLAN  
STAGE 1B**

SCALE: SHEET NO. 5 OF 10 SHEETS STA TO STA

F.A.I. RTE.	SECTION	COUNTY	TOTAL SHEETS	SHEET NO.
74	(81-IHVB & 81-IHVB-1)M-3	ROCK ISLAND	69	28

CONTRACT No. 64H83  
ILLINOIS FED. AID PROJECT

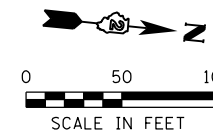

EXIT 2  
7th Ave  
1/2 MILE

EXIT 1  
River Dr  
NEXT RIGHT

COVER SPEED LIMIT 50 COVER

EXISTING SIGNS LOCATED AT IOWA BORDER

COVER SPEED LIMIT 50 COVER

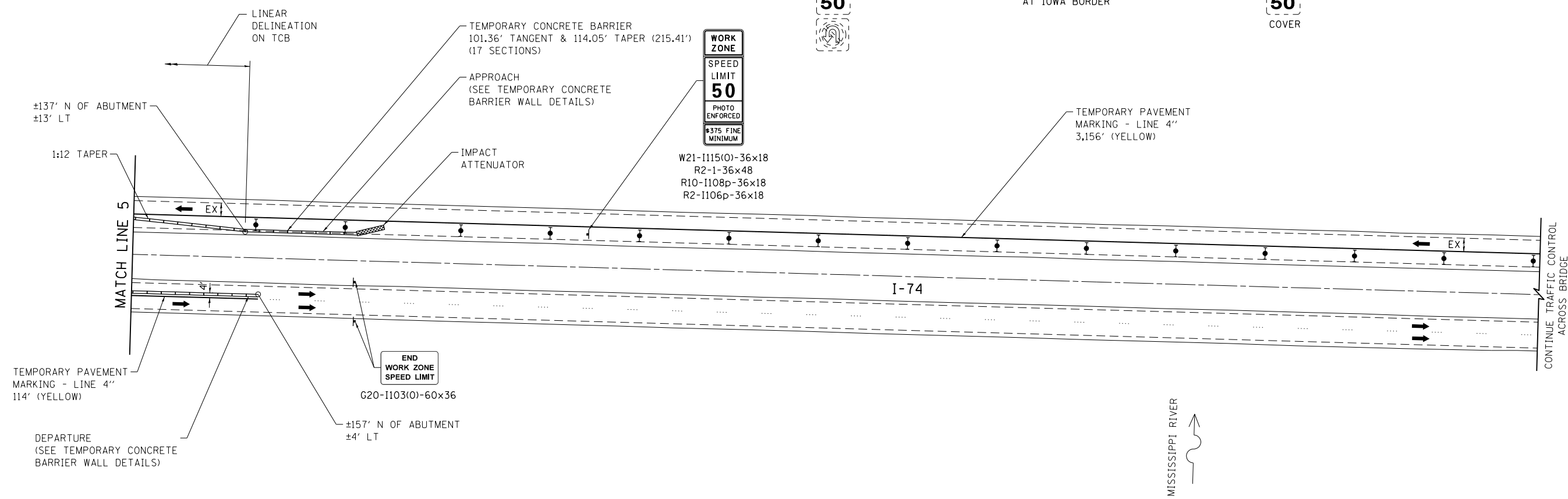

**NOTES:**

1. ALL OFFSETS ARE MEASURED FROM CENTER SKIP DASH LINE IN RESPECTIVE DIRECTIONS.
2. THE CONTRACTOR SHALL PLACE CHECK BARRICADES AS NOTED ON HWY STD 701401.
3. BARRIER WALL OFFSETS ARE MEASURED TO THE CONSTRUCTION SIDE OF BARRIER WALL.

**STAGING LEGEND**

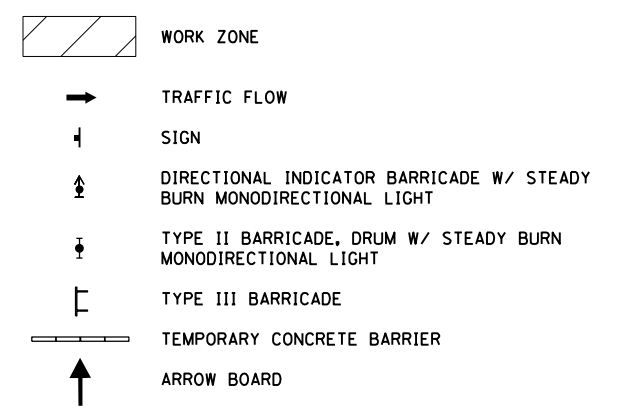

FILE NAME = S:\Projects\2012\JOBS\12-92-09\PTB 164 11 02 1-74 Bridge Repairs-Traffic Control Plans\CADD\CADD Sheets\0264H83-sht-Staging-1B06.dgn  
 MODEL = Default  
 PLOT DRIVER = 12-92-09\_PDF.plt



USER NAME = twalker	DESIGNED - MTM	REVISED -
FILE NAME = 0264H83-sht-Staging-1B06.dgn	DRAWN - RG	REVISED -
PLOT SCALE = 100.0000' / in.	CHECKED - MCV	REVISED -
PLOT DATE = 8/7/2015	DATE - 7/31/2015	REVISED -

**STATE OF ILLINOIS  
DEPARTMENT OF TRANSPORTATION**

**I-74 STAGING PLAN  
STAGE 1B**

SCALE: SHEET NO. 6 OF 10 SHEETS STA TO STA

F.A.I. RTE.	SECTION	COUNTY	TOTAL SHEETS	SHEET NO.
74	181-IHV & 81-IHV-B-1M-3	ROCK ISLAND	69	29
				CONTRACT No. 64H83
ILLINOIS FED. AID PROJECT				

FILE NAME = S:\Projects\2012\JOBS\12-92-09\PTB 164 11 02 1-74 Bridge Repairs-Traffic Control Plans\CADD\CADD Sheets\0264H83-sht-Staging-1B07.dgn  
 MODEL = Default  
 PLOT DRIVER = 12-92-09\_PDF.plt

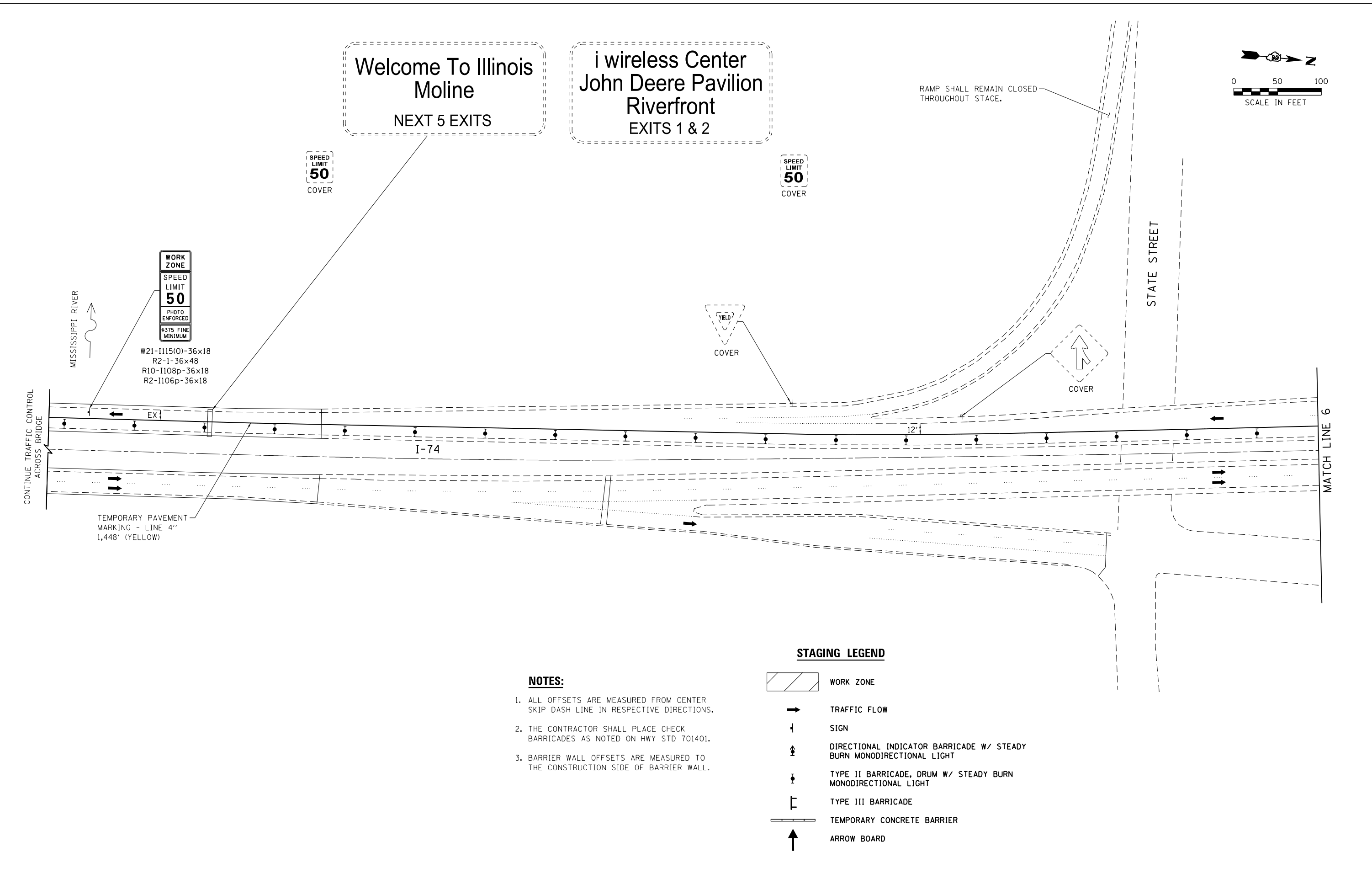

- NOTES:**
1. ALL OFFSETS ARE MEASURED FROM CENTER SKIP DASH LINE IN RESPECTIVE DIRECTIONS.
  2. THE CONTRACTOR SHALL PLACE CHECK BARRICADES AS NOTED ON HWY STD 701401.
  3. BARRIER WALL OFFSETS ARE MEASURED TO THE CONSTRUCTION SIDE OF BARRIER WALL.

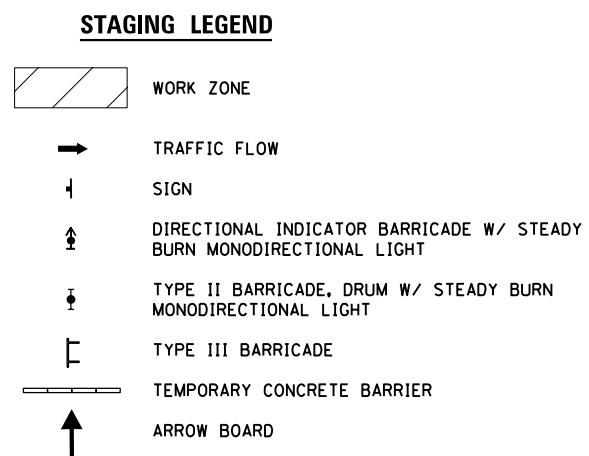

USER NAME = twalker	DESIGNED - MTM	REVISED -
FILE NAME = 0264H83-sht-Staging-1B07.dgn	DRAWN - RG	REVISED -
PLOT SCALE = 100.0000' / 1in.	CHECKED - MCV	REVISED -
PLOT DATE = 8/7/2015	DATE - 7/31/2015	REVISED -

**STATE OF ILLINOIS  
DEPARTMENT OF TRANSPORTATION**

**I-74 STAGING PLAN  
STAGE 1B**

SCALE: SHEET NO. 7 OF 10 SHEETS STA TO STA



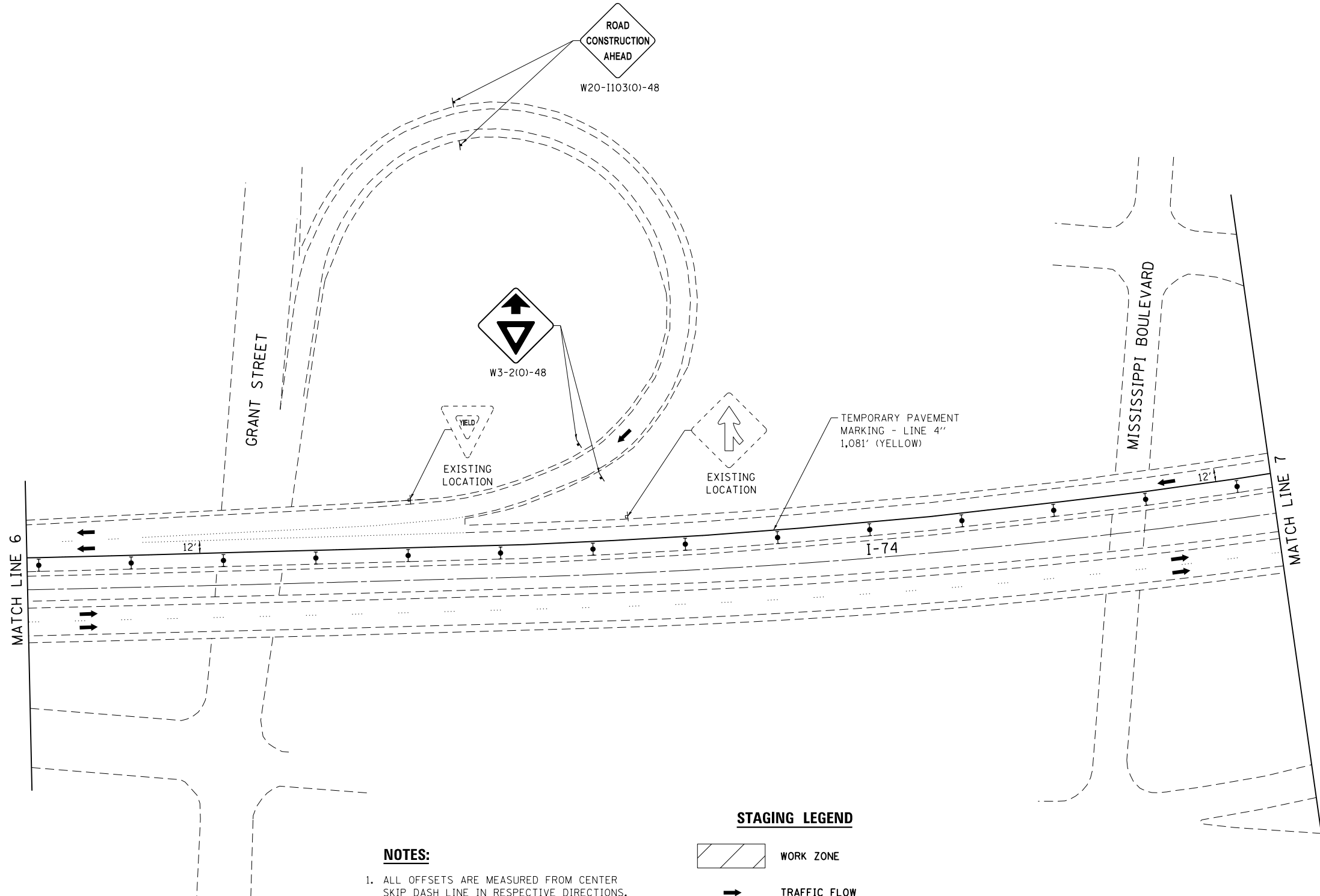
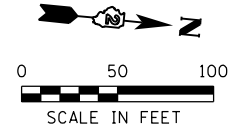





F.A.I. RTE.	SECTION	COUNTY	TOTAL SHEETS	SHEET NO.
74	181-IHVB & 81-IHVB-1JM-3	ROCK ISLAND	69	30
CONTRACT No. 64H83			ILLINOIS FED. AID PROJECT	

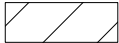

**NOTES:**

1. ALL OFFSETS ARE MEASURED FROM CENTER SKIP DASH LINE IN RESPECTIVE DIRECTIONS.
2. THE CONTRACTOR SHALL PLACE CHECK BARRICADES AS NOTED ON HWY STD 701401.
3. BARRIER WALL OFFSETS ARE MEASURED TO THE CONSTRUCTION SIDE OF BARRIER WALL.

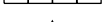
**STAGING LEGEND**

-  WORK ZONE
-  TRAFFIC FLOW
-  SIGN
-  DIRECTIONAL INDICATOR BARRICADE W/ STEADY BURN MONODIRECTIONAL LIGHT
-  TYPE II BARRICADE, DRUM W/ STEADY BURN MONODIRECTIONAL LIGHT
-  TYPE III BARRICADE
-  TEMPORARY CONCRETE BARRIER
-  ARROW BOARD

FILE NAME = S:\Projects\2012\JOBS\12-92-09\PTB 164 11 02 1-74 Bridge Repairs-Traffic Control Plans\CADD Sheets\0264H83-sht-Staging-1B08.dgn  
 MODEL = Default  
 PLOT DRIVER = 12-92-09\_PDF.plt



USER NAME = twalker	DESIGNED - MTM	REVISED -
FILE NAME = 0264H83-sht-Staging-1B08.dgn	DRAWN - RG	REVISED -
PLOT SCALE = 100.0000' / 1in.	CHECKED - MCV	REVISED -
PLOT DATE = 8/7/2015	DATE - 7/31/2015	REVISED -

**STATE OF ILLINOIS  
DEPARTMENT OF TRANSPORTATION**

<b>I-74 STAGING PLAN STAGE 1B</b>			
SCALE:	SHEET NO. 8 OF 10 SHEETS	STA	TO STA

F.A.I. RTE.	SECTION	COUNTY	TOTAL SHEETS	SHEET NO.
74	181-IHVB & 81-IHVB-1JM-3	ROCK ISLAND	69	31
CONTRACT No. 64H83				
ILLINOIS FED. AID PROJECT				

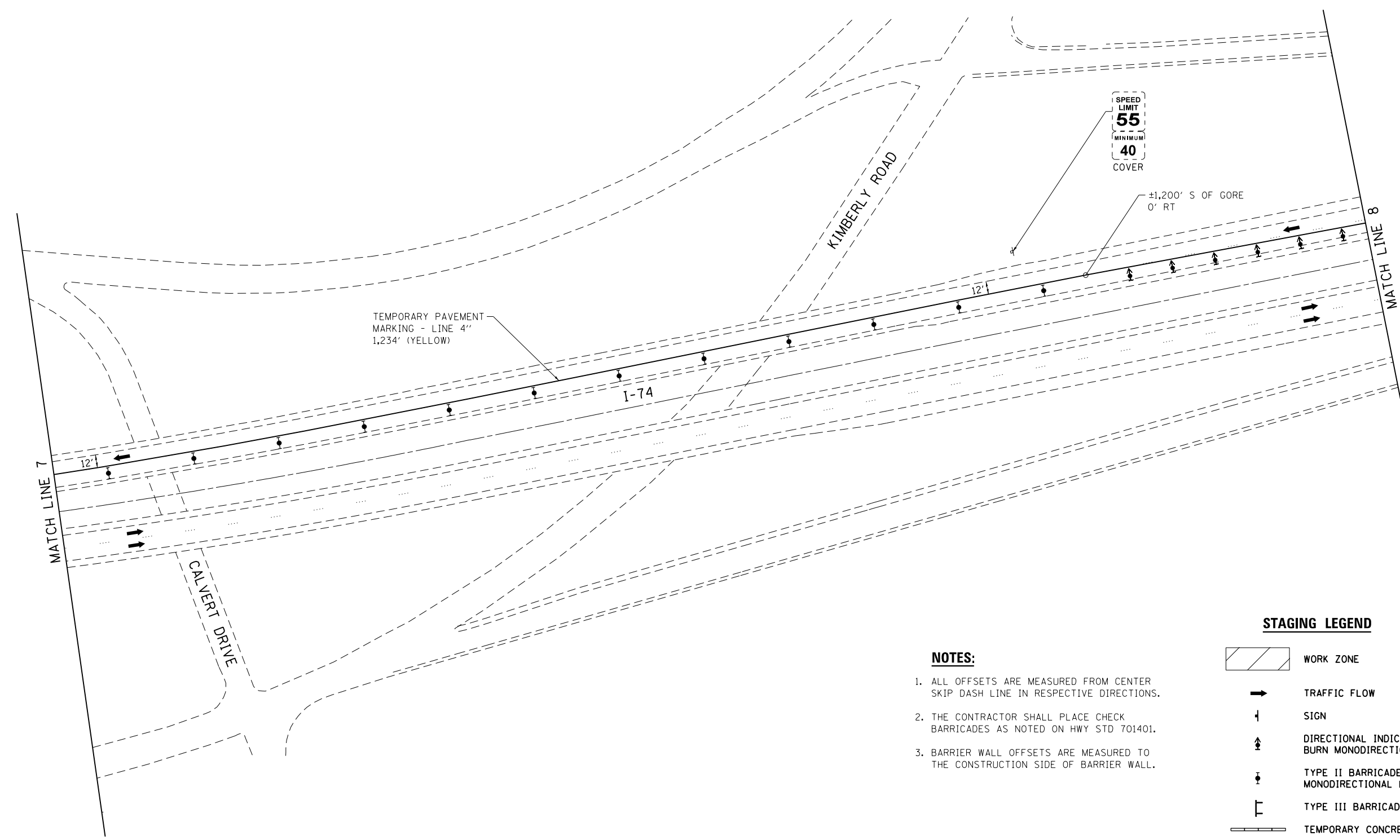
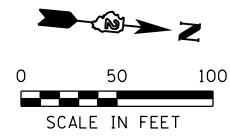

TEMPORARY PAVEMENT MARKING - LINE 4" 1,234' (YELLOW)

SPEED LIMIT 55  
MINIMUM 40  
COVER

±1,200' S OF GORE  
0' RT

MATCH LINE 7

MATCH LINE 8

KIMBERLY ROAD

CALVERT DRIVE

I-74

**NOTES:**

1. ALL OFFSETS ARE MEASURED FROM CENTER SKIP DASH LINE IN RESPECTIVE DIRECTIONS.
2. THE CONTRACTOR SHALL PLACE CHECK BARRICADES AS NOTED ON HWY STD 701401.
3. BARRIER WALL OFFSETS ARE MEASURED TO THE CONSTRUCTION SIDE OF BARRIER WALL.

**STAGING LEGEND**

- WORK ZONE
- TRAFFIC FLOW
- SIGN
- DIRECTIONAL INDICATOR BARRICADE W/ STEADY BURN MONODIRECTIONAL LIGHT
- TYPE II BARRICADE, DRUM W/ STEADY BURN MONODIRECTIONAL LIGHT
- TYPE III BARRICADE
- TEMPORARY CONCRETE BARRIER
- ARROW BOARD

FILE NAME = S:\Projects\2012\JOBS\12-92-09\PTB 164 11 02 1-74 Bridge Repairs-Traffic Control Plans\CADD Sheets\0264H83-sht-Staging-1B09.dgn  
 MODEL = Default  
 PLOT DRIVER = 12-92-09\_PDF.plt



USER NAME = twalker	DESIGNED - MTM	REVISED -
FILE NAME = 0264H83-sht-Staging-1B09.dgn	DRAWN - RG	REVISED -
PLOT SCALE = 100.0000' / 1in.	CHECKED - MCV	REVISED -
PLOT DATE = 8/7/2015	DATE - 7/31/2015	REVISED -

**STATE OF ILLINOIS  
DEPARTMENT OF TRANSPORTATION**

**I-74 STAGING PLAN  
STAGE 1B**

SCALE: SHEET NO. 9 OF 10 SHEETS STA TO STA

F.A.I. RTE.	SECTION	COUNTY	TOTAL SHEETS	SHEET NO.
74	181-IHVB & 81-IHVB-1JM-3	ROCK ISLAND	69	32
				CONTRACT No. 64H83
ILLINOIS FED. AID PROJECT				



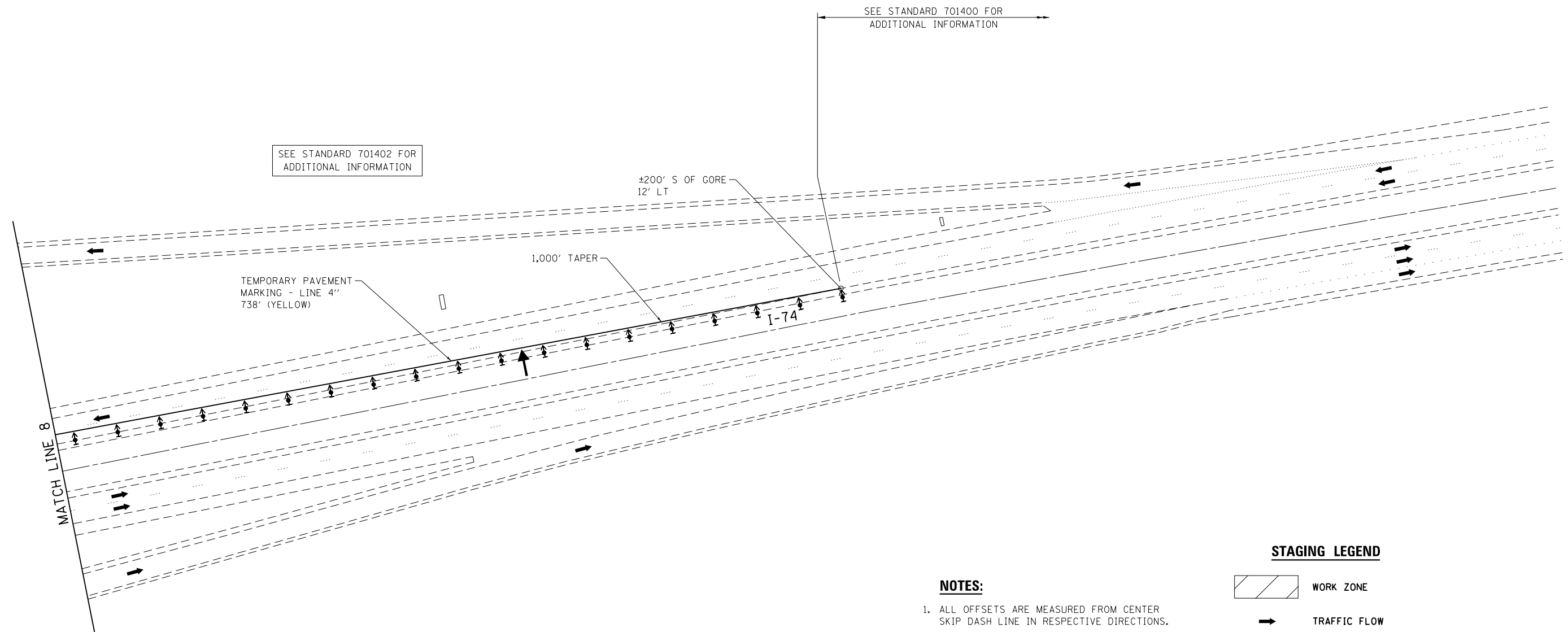
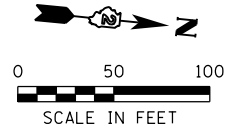

SEE STANDARD 701402 FOR  
ADDITIONAL INFORMATION

SEE STANDARD 701400 FOR  
ADDITIONAL INFORMATION

±200' S OF GORE  
12' LT









1,000' TAPER

TEMPORARY PAVEMENT  
MARKING - LINE 4"  
738' (YELLOW)

I-74

MATCH LINE 8

**STAGING LEGEND**

-  WORK ZONE
-  TRAFFIC FLOW
-  SIGN
-  DIRECTIONAL INDICATOR BARRICADE W/ STEADY BURN MONODIRECTIONAL LIGHT
-  TYPE II BARRICADE, DRUM W/ STEADY BURN MONODIRECTIONAL LIGHT
-  TYPE III BARRICADE
-  TEMPORARY CONCRETE BARRIER
-  ARROW BOARD

**NOTES:**

1. ALL OFFSETS ARE MEASURED FROM CENTER SKIP DASH LINE IN RESPECTIVE DIRECTIONS.
2. THE CONTRACTOR SHALL PLACE CHECK BARRICADES AS NOTED ON HWY STD 701401.
3. BARRIER WALL OFFSETS ARE MEASURED TO THE CONSTRUCTION SIDE OF BARRIER WALL.

FILE NAME = S:\Projects\2012\JOBS\12-92-09\PTB 164 11 02 1-74 Bridge Repairs-Traffic Control\Plans\CADD Sheets\0264H83-sht-Staging-1B10.dgn  
 MODEL = Default  
 PLOT DRIVER = 12-92-091.PDF.plt



USER NAME = twalker	DESIGNED - MTM	REVISED -
FILE NAME = 0264H83-sht-Staging-1B10.dgn	DRAWN - RG	REVISED -
PLOT SCALE = 100.0000' / 1in.	CHECKED - MCV	REVISED -
PLOT DATE = 8/7/2015	DATE - 7/31/2015	REVISED -

**STATE OF ILLINOIS  
DEPARTMENT OF TRANSPORTATION**

**I-74 STAGING PLAN  
STAGE 1B**

SCALE: SHEET NO. 10 OF 10 SHEETS STA TO STA

F.A.I. RTE.	SECTION	COUNTY	TOTAL SHEETS	SHEET NO.
74	181-1HVB & 81-1HVB-1JM-3	ROCK ISLAND	69	33
				CONTRACT No. 64H83
ILLINOIS FED. AID PROJECT				

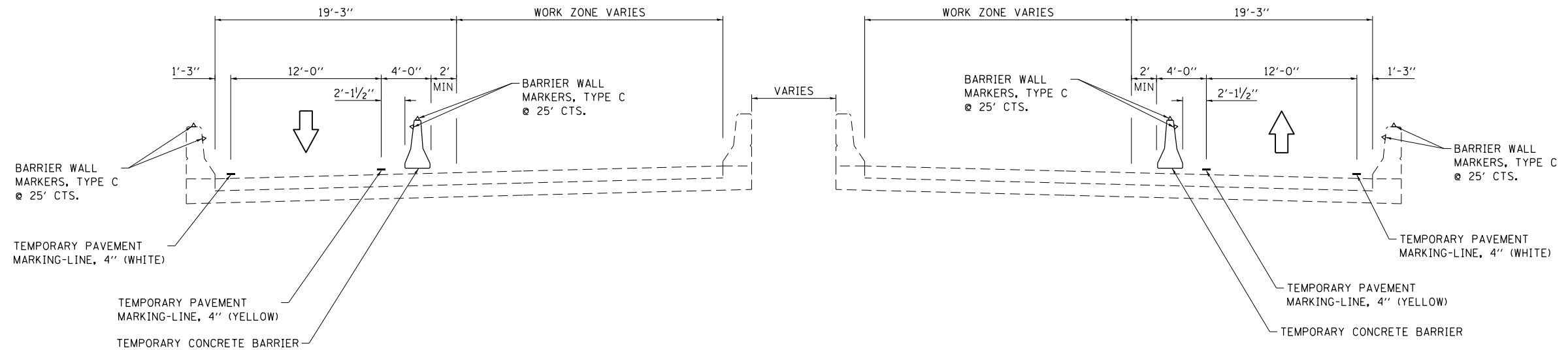

**EASTBOUND**

**WESTBOUND**

**TYPICAL SECTION – STAGE 2A**

**STAGING GENERAL NOTES**

1. TRAFFIC CONTROL DEVICES SHOWN ON THESE PLANS MAY BE ADJUSTED TO FIT FIELD CONDITIONS WITH PRIOR APPROVAL FROM THE ENGINEER AND TRAFFIC OPERATIONS.
2. TRAFFIC CONTROL SHALL BE IN ACCORDANCE WITH APPLICABLE STANDARDS. CHANNELIZING DEVICES SHALL BE IN ACCORDANCE WITH IDOT HWY STD 701901.
3. THE CONTRACTOR SHALL PLACE CHECK BARRICADES AS NOTED ON HWY STD 701401.
4. NO EQUIPMENT OR MATERIALS ARE TO BE STORED WITHIN THE 2' BUFFER AREA BEHIND THE UNPINNED TEMPORARY CONCRETE BARRIER.

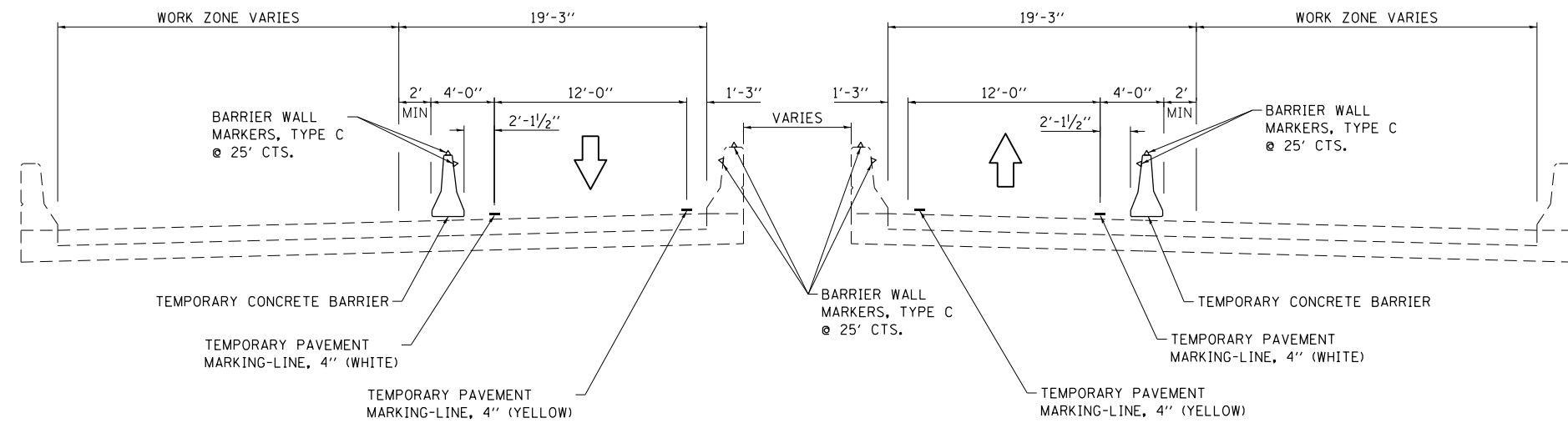

**EASTBOUND**

**WESTBOUND**

**TYPICAL SECTION – STAGE 2B**

FILE NAME = S:\Projects\2012\JOBS\12-02-09\PTB 164 11 02 1-74 Bridge Repairs-Traffic Control Plans\CADD\Sheet\0264H83-sht-Staging\_Typical.dgn  
 MODEL = Default  
 PLOT DRIVER = 12-02-09\_PDF.plt



USER NAME = twalker	DESIGNED - MTM	REVISED -
FILE NAME = 0264H83-sht-Staging_Typical.dgn	DRAWN - RG	REVISED -
PLOT SCALE = 10.0000' / in.	CHECKED - MCV	REVISED -
PLOT DATE = 8/7/2015	DATE - 7/31/2015	REVISED -









**STATE OF ILLINOIS  
DEPARTMENT OF TRANSPORTATION**

**TYPICAL SECTIONS  
STAGE 2A & 2B**

SCALE:	SHEET NO.	OF SHEETS	STA	TO STA
--------	-----------	-----------	-----	--------

F.A.I. RTE.	SECTION	COUNTY	TOTAL SHEETS	SHEET NO.
74	(81-IHVB & 81-IHVB-1)M-3	ROCK ISLAND	69	34
CONTRACT No. 64H83				
ILLINOIS FED. AID PROJECT				

**STAGING LEGEND**

-  WORK ZONE
-  TRAFFIC FLOW
-  SIGN
-  DIRECTIONAL INDICATOR BARRICADE W/ STEADY BURN MONODIRECTIONAL LIGHT
-  TYPE II BARRICADE, DRUM W/ STEADY BURN MONODIRECTIONAL LIGHT
-  TYPE III BARRICADE
-  TEMPORARY CONCRETE BARRIER
-  ARROW BOARD

**NOTES:**

1. ALL OFFSETS ARE MEASURED FROM CENTER SKIP DASH LINE IN RESPECTIVE DIRECTIONS.
2. THE CONTRACTOR SHALL PLACE CHECK BARRICADES AS NOTED ON HWY STD 701401.
3. BARRIER WALL OFFSETS ARE MEASURED TO THE CONSTRUCTION SIDE OF BARRIER WALL.

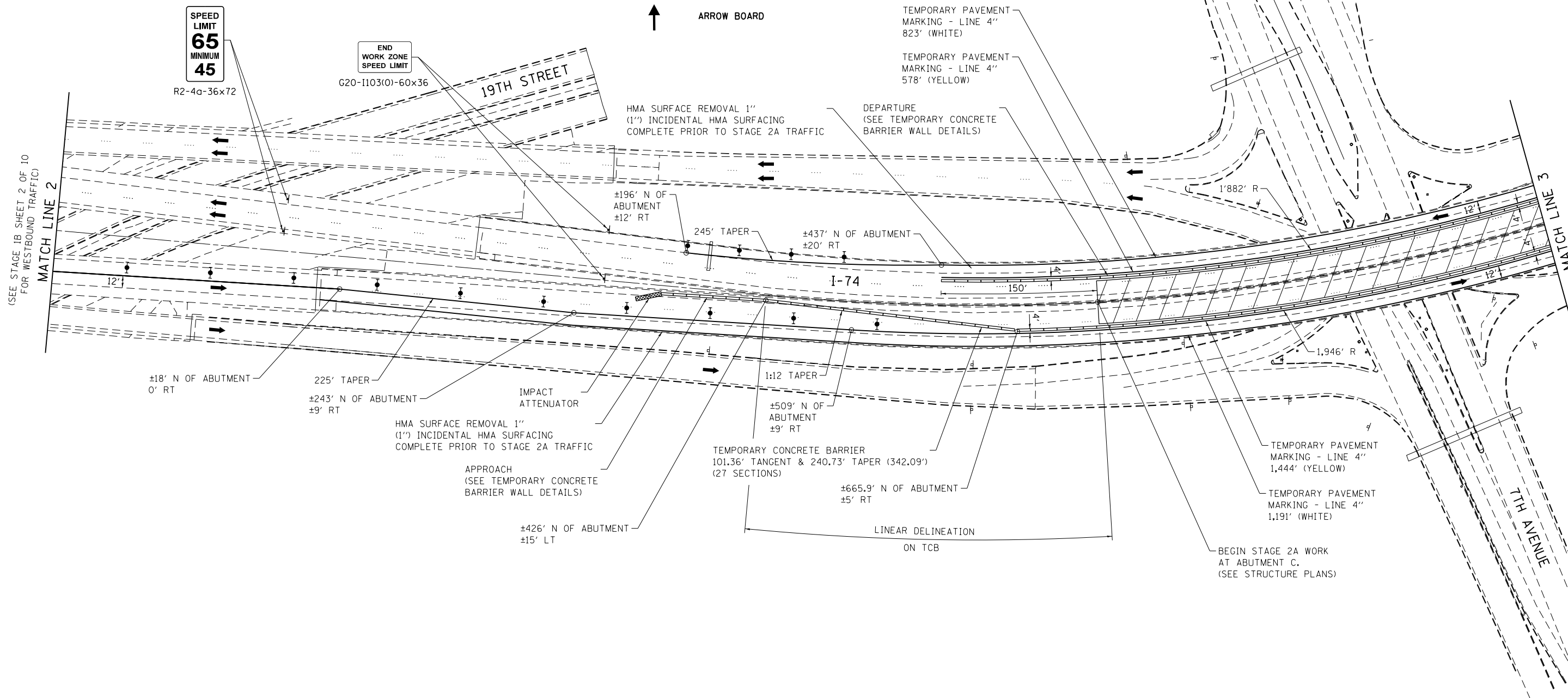
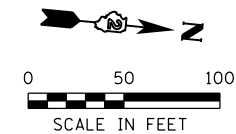

FILE NAME = S:\Projects\2012\JOBS\12-92-09\PTB 164 11 02 1-74 Bridge Repairs-Traffic Control\Plans\CADD Sheets\0264H83-sht-Staging-2A03.dgn  
 MODEL = Default  
 PLOT DRIVER = 12-92-09\_PDF.plt



USER NAME = twalker	DESIGNED - MTM	REVISED -
FILE NAME = 0264H83-sht-Staging-2A03.dgn	DRAWN - RG	REVISED -
PLOT SCALE = 100.0000' / in.	CHECKED - MCV	REVISED -
PLOT DATE = 8/7/2015	DATE - 7/31/2015	REVISED -

**STATE OF ILLINOIS  
DEPARTMENT OF TRANSPORTATION**

**I-74 STAGING PLAN  
STAGE 2A**

SCALE: SHEET NO. 1 OF 3 SHEETS STA TO STA







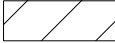

F.A.I. RTE.	SECTION	COUNTY	TOTAL SHEETS	SHEET NO.
74	(81-1HVB & 81-1HVB-1)M-3	ROCK ISLAND	69	35
CONTRACT No. 64H83				
ILLINOIS FED. AID PROJECT				

FILE NAME = S:\Projects\2012\JOBS\12-92-09\PTB 164 11 02 1-74 Bridge Repairs-Traffic Control\Plans\CADD Sheets\0264H83-sht-Staging-2A04.dgn  
 MODEL = Default  
 PLOT DRIVER = 12-92-09\_PDF.plt

**NOTES:**

1. ALL OFFSETS ARE MEASURED FROM CENTER SKIP DASH LINE IN RESPECTIVE DIRECTIONS.
2. THE CONTRACTOR SHALL PLACE CHECK BARRICADES AS NOTED ON HWY STD 701401.
3. BARRIER WALL OFFSETS ARE MEASURED TO THE CONSTRUCTION SIDE OF BARRIER WALL.

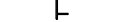
**STAGING LEGEND**

-  WORK ZONE
-  TRAFFIC FLOW
-  SIGN
-  DIRECTIONAL INDICATOR BARRICADE W/ STEADY BURN MONODIRECTIONAL LIGHT
-  TYPE II BARRICADE, DRUM W/ STEADY BURN MONODIRECTIONAL LIGHT
-  TYPE III BARRICADE
-  TEMPORARY CONCRETE BARRIER
-  ARROW BOARD

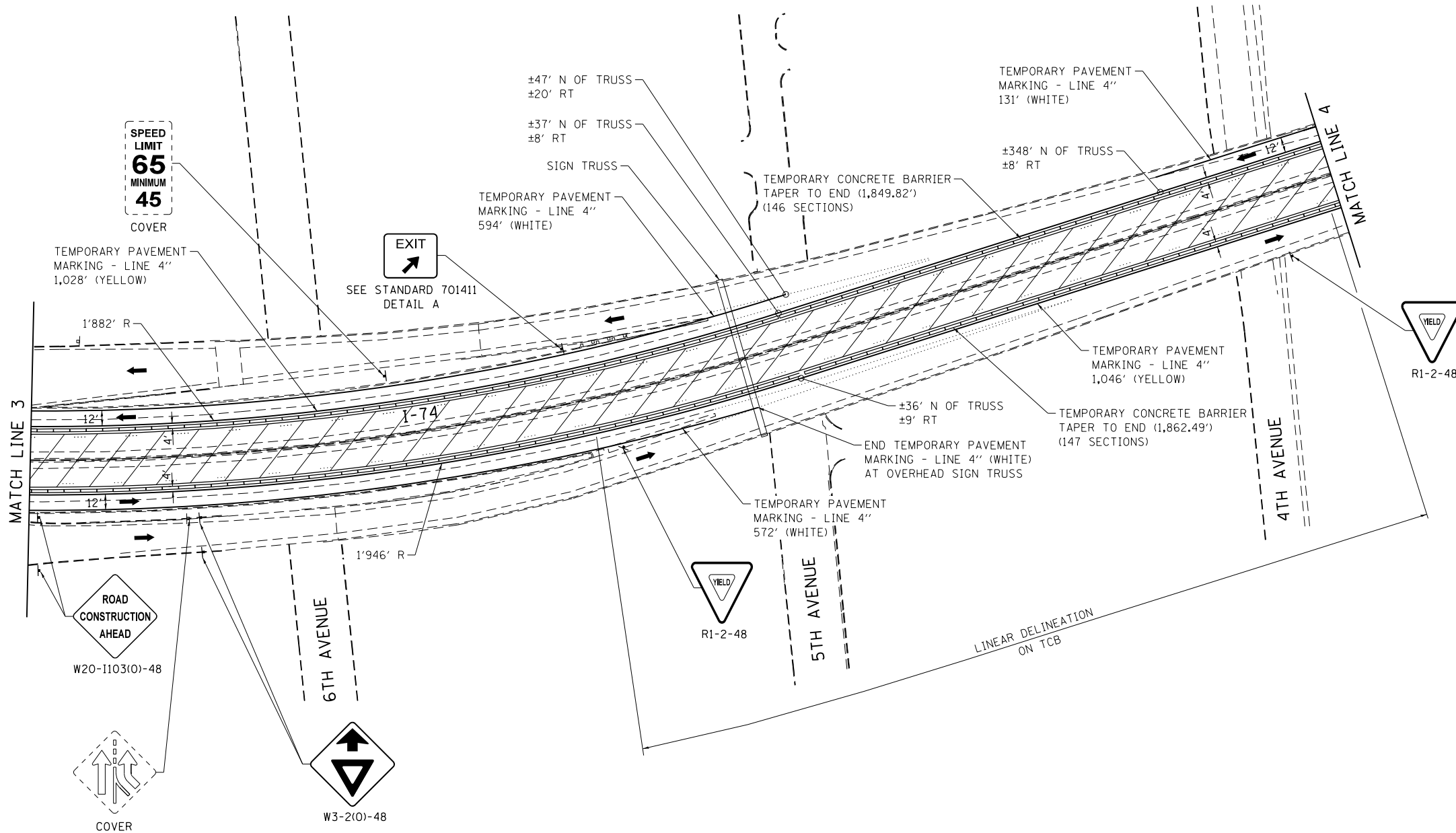
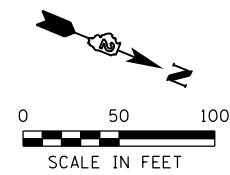

USER NAME = twalker	DESIGNED - MTM	REVISED -
FILE NAME = 0264H83-sht-Staging-2A04.dgn	DRAWN - RG	REVISED -
PLOT SCALE = 100.0000' / 1in.	CHECKED - MCV	REVISED -
PLOT DATE = 8/7/2015	DATE - 7/31/2015	REVISED -

**STATE OF ILLINOIS  
DEPARTMENT OF TRANSPORTATION**

**I-74 STAGING PLAN  
STAGE 2A**

SCALE: SHEET NO. 2 OF 3 SHEETS STA TO STA

F.A.I. RTE.	SECTION	COUNTY	TOTAL SHEETS	SHEET NO.
74	(81-1HVB & 81-1HVB-1)M-3	ROCK ISLAND	69	36
CONTRACT No. 64H83				
ILLINOIS FED. AID PROJECT				

EXIT 2  
7th Ave  
NEXT RIGHT

i wireless Center  
John Deere Pavilion  
Riverfront  
EXITS 1 & 2

EXIT 1  
River Dr  
RAMP 20 MPH

SPEED LIMIT  
65  
MINIMUM  
45  
COVER

SPEED LIMIT  
50

SPEED ZONE  
AHEAD  
50  
MPH

END WORK ZONE  
SPEED LIMIT  
G20-1103(10)-60x36

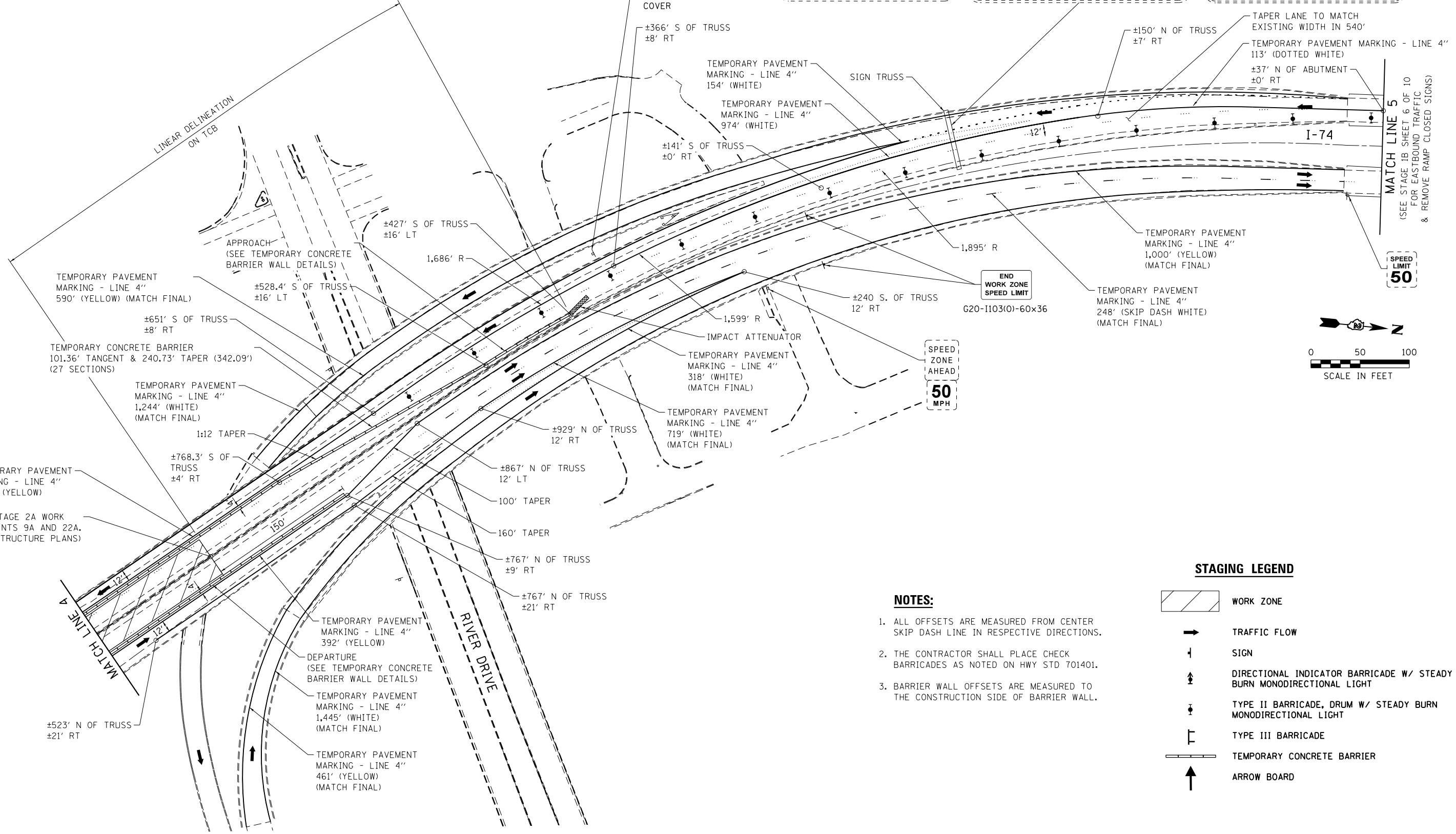
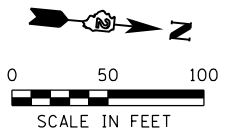

**NOTES:**

- ALL OFFSETS ARE MEASURED FROM CENTER SKIP DASH LINE IN RESPECTIVE DIRECTIONS.
- THE CONTRACTOR SHALL PLACE CHECK BARRICADES AS NOTED ON HWY STD 701401.
- BARRIER WALL OFFSETS ARE MEASURED TO THE CONSTRUCTION SIDE OF BARRIER WALL.

**STAGING LEGEND**

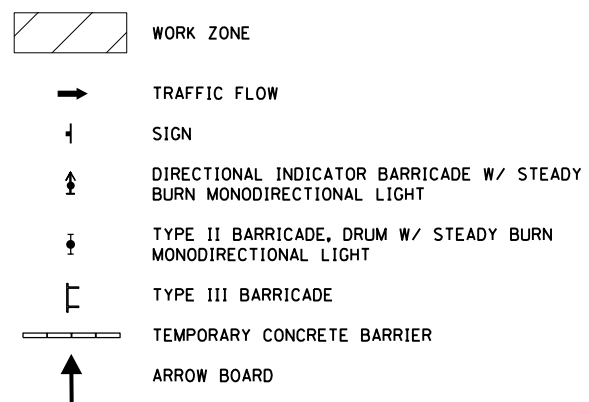

FILE NAME = S:\Projects\2012\JOBS\12-92-09\PTB 164 11 02 1-74 Bridge Repairs-Traffic Control Plans\CADD Sheets\0264H83-sht-Staging-2A05.dgn  
MODEL = Default  
PLOT DRIVER = 12-92-09\_PDF.plt



USER NAME = twalker	DESIGNED - MTM	REVISED -
FILE NAME = 0264H83-sht-Staging-2A05.dgn	DRAWN - RG	REVISED -
PLOT SCALE = 100.0000' / 1in.	CHECKED - MCV	REVISED -
PLOT DATE = 8/7/2015	DATE - 7/31/2015	REVISED -

STATE OF ILLINOIS  
DEPARTMENT OF TRANSPORTATION

I-74 STAGING PLAN  
STAGE 2A  
SCALE: SHEET NO. 3 OF 3 SHEETS STA TO STA

F.A.I. RTE.	SECTION	COUNTY	TOTAL SHEETS	SHEET NO.
74	(81-IHVB & 81-IHVB-1)M-3	ROCK ISLAND	69	37
CONTRACT No. 64H83				
ILLINOIS FED. AID PROJECT				

**NOTES:**

- FOR TEMPORARY RAMP CLOSURE, USE STANDARD 701451 FOR ADDITIONAL GUIDANCE, EXCEPT USE "RAMP CLOSED AHEAD" INSTEAD OF "ROAD CLOSED AHEAD" OR "RAMP CLOSED" INSTEAD OF "EXIT CLOSED"
- FINAL SIGN LOCATIONS TO BE DETERMINED IN THE FIELD BY THE ENGINEER. LOCATIONS SHOWN ARE APPROXIMATE AND FOR PLAN PURPOSES ONLY.
- ALL SIGNS SHALL BE SET AT A 7 FOOT MOUNTING HEIGHT ON TELSPAR OR CHANNEL SIGN POSTS.
- THE DIRECTIONAL ARROW SIGN AT THE SOUTHWEST CORNER OF 23RD STREET AND 4TH AVENUE SHALL BE POINTED BACK TO THE SOUTH (LEFT) AFTER COMPLETION OF THIS PROJECT.

**LEGEND**

- WORK ZONE
- RIVER DRIVE ENTRANCE RAMP DETOUR ROUTE
- RIVER DRIVE EXIT RAMP DETOUR ROUTE
- PORTABLE CHANGEABLE MESSAGE SIGN (PCMS)
- TYPE III BARRICADE
- DRUM W/ STEADY BURN LIGHT
- SIGN

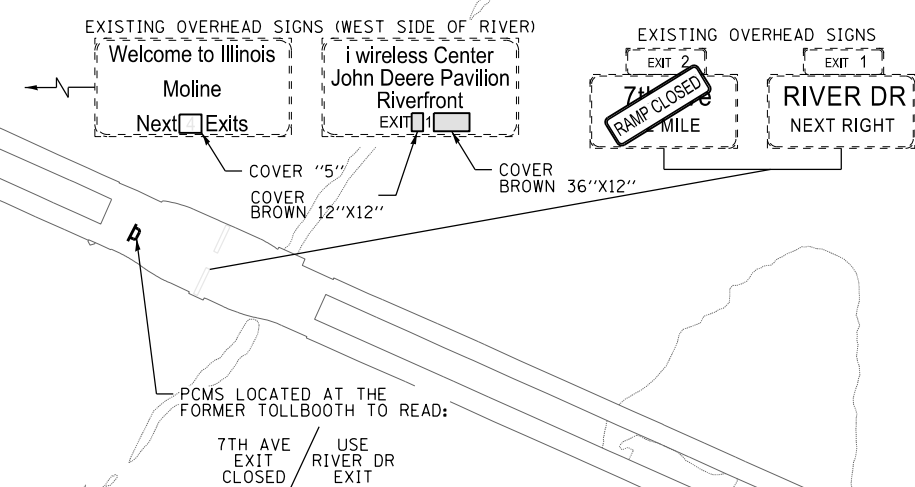
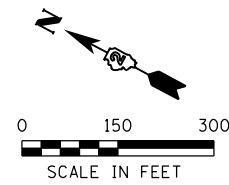

**SIGN LEGEND**

- SPECIAL-(O) 24x12
- M6-1R-(O) 21x15
- M6-1L-(O) 21x15
- M6-3-(O) 21x15
- M6-2L-(O) 21x15
- M4-5-(O) 24x12
- M3-2-(O) 24x12
- M3-4-(O) 24x12
- (O) 72x18
- W20-2-(O) 48
- (O) 48
- R11-2-(O) 48x30
- M1-1 24x24

(O) = ORANGE SIGN

\*SIGN DIMENSIONS ARE GIVEN IN INCHES

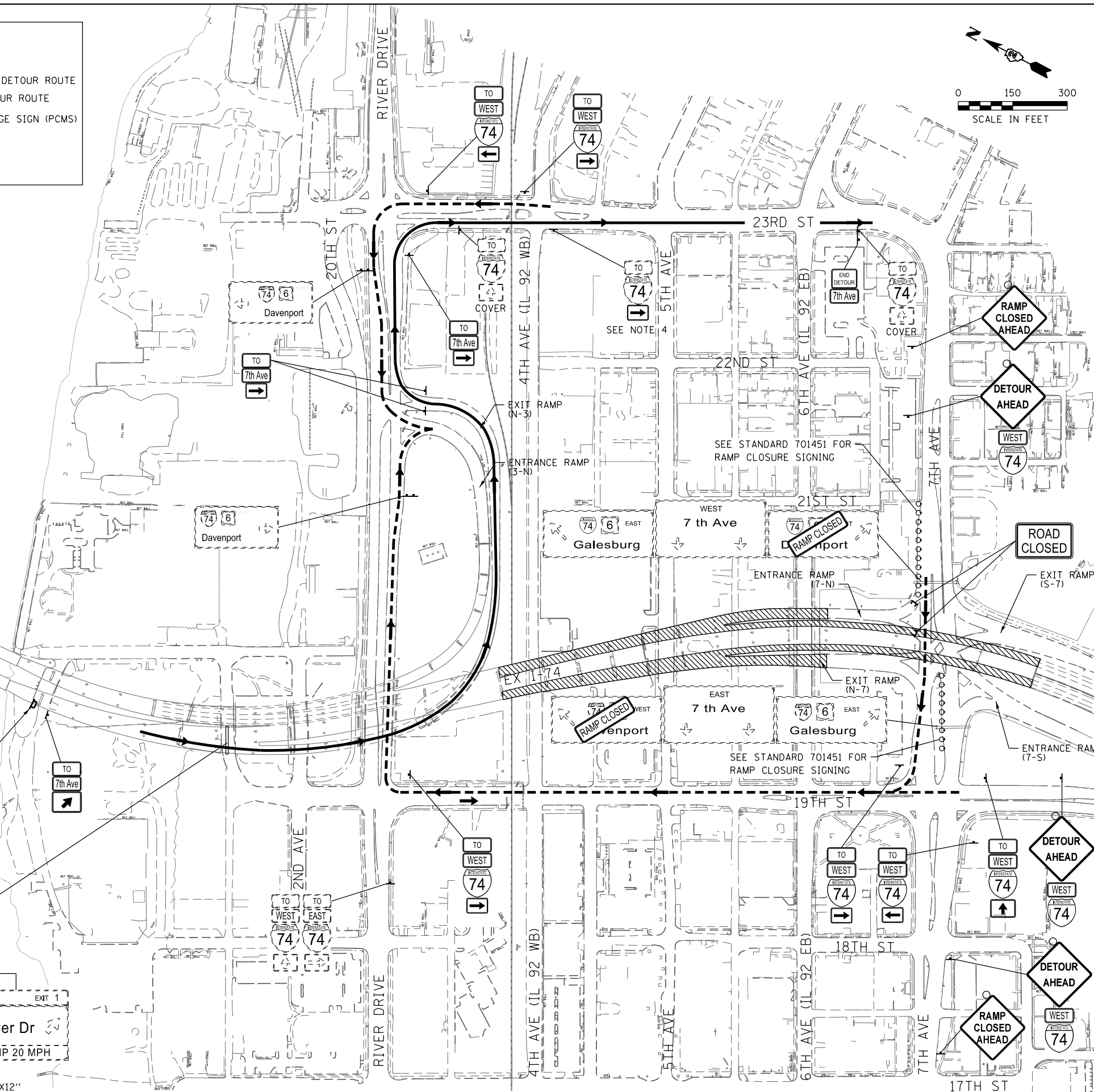
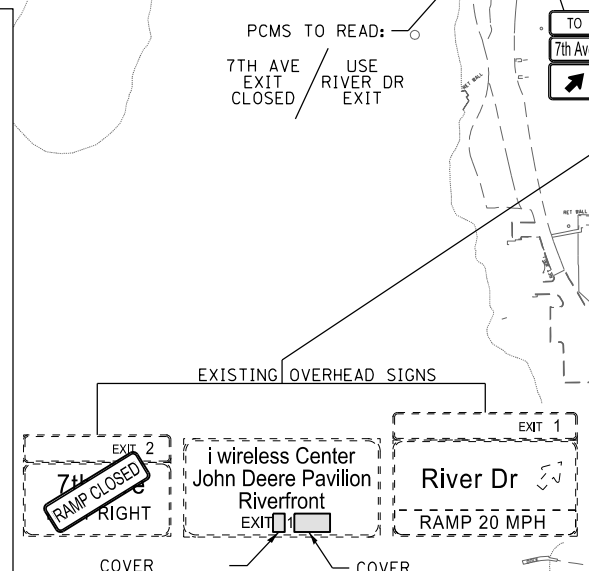

FILE NAME = S:\Projects\2012\085\12-92-09 PTB 164 11 02 1-74 Bridge Repairs-Traffic Control Plans\CADD\CADD Sheets\0264H83-sht-Staging\_2B Detour.dgn  
 MODEL = Sheet  
 PLOT DRIVER = 12-92-091.PDF.pltcf9



USER NAME = twalker	DESIGNED - MTM	REVISED -
FILE NAME = D264H83-sht-Staging_2B Detour.dgn	DRAWN - RG	REVISED -
PLOT SCALE = 300.0000' / in.	CHECKED - MCV	REVISED -
PLOT DATE = 8/7/2015	DATE - 7/31/2015	REVISED -

**STATE OF ILLINOIS  
DEPARTMENT OF TRANSPORTATION**

**STAGE 2B DETOUR  
7TH AVENUE**

SCALE:	SHEET NO.	OF SHEETS	STA	TO STA
--------	-----------	-----------	-----	--------

F.A.I. RTE.	SECTION	COUNTY	TOTAL SHEETS	SHEET NO.
74	(81-IHV-B & 81-IHV-B-1M-3)	ROCK ISLAND	69	38
CONTRACT No. 64H83			ILLINOIS FED. AID PROJECT	



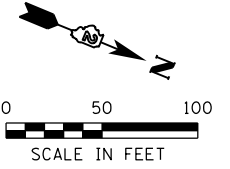

**STAGING LEGEND**

- WORK ZONE
- TRAFFIC FLOW
- SIGN
- DIRECTIONAL INDICATOR BARRICADE W/ STEADY BURN MONODIRECTIONAL LIGHT
- TYPE II BARRICADE, DRUM W/ STEADY BURN MONODIRECTIONAL LIGHT
- TYPE III BARRICADE
- TEMPORARY CONCRETE BARRIER
- ARROW BOARD

**NOTES:**

1. ALL OFFSETS ARE MEASURED FROM CENTER SKIP DASH LINE IN RESPECTIVE DIRECTIONS.
2. THE CONTRACTOR SHALL PLACE CHECK BARRICADES AS NOTED ON HWY STD 701401.
3. BARRIER WALL OFFSETS ARE MEASURED TO THE CONSTRUCTION SIDE OF BARRIER WALL.

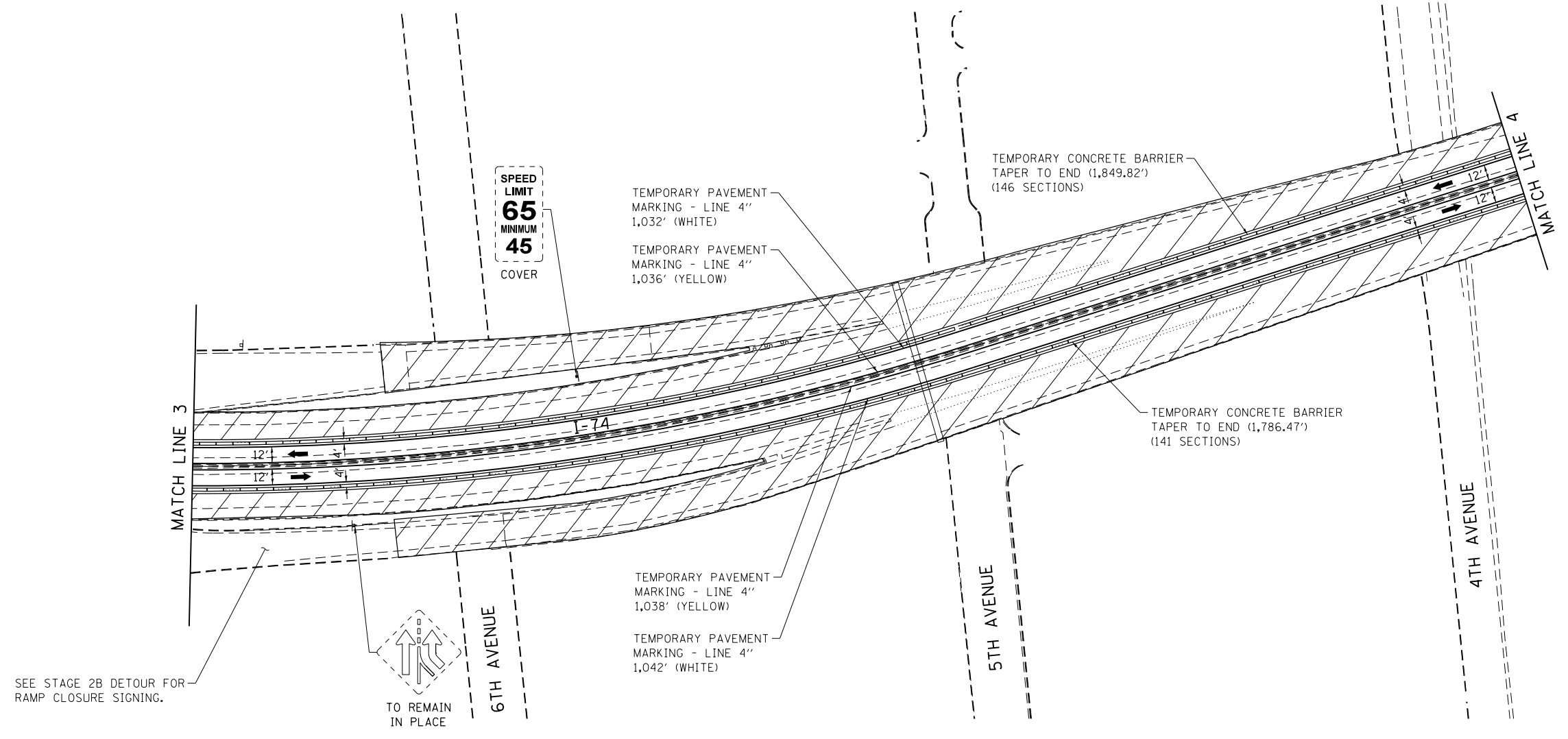

SEE STAGE 2B DETOUR FOR RAMP CLOSURE SIGNING.



6TH AVENUE

5TH AVENUE

4TH AVENUE

FILE NAME = S:\Projects\2812\2812-92-09\PTB 164 11 02 1-74 Bridge Repairs-Traffic Control\Plans\CADD\CADD Sheets\0264H83-sht-Staging-2B04.dgn  
 MODEL = Default  
 PLOT DRIVER = 12-92-09\_PDF.plt



USER NAME = twalker	DESIGNED - MTM	REVISED -
FILE NAME = 0264H83-sht-Staging-2B04.dgn	DRAWN - RG	REVISED -
PLOT SCALE = 100.0000' / in.	CHECKED - MCV	REVISED -
PLOT DATE = 8/7/2015	DATE - 7/31/2015	REVISED -

**STATE OF ILLINOIS  
DEPARTMENT OF TRANSPORTATION**

<b>I-74 STAGING PLAN STAGE 2B</b>	
SCALE:	SHEET NO. 2 OF 3 SHEETS STA TO STA

F.A.I. RTE.	SECTION	COUNTY	TOTAL SHEETS	SHEET NO.
74	181-1HVB & 81-1HVB-1JM-3	ROCK ISLAND	69	40
CONTRACT No. 64H83				
ILLINOIS FED. AID PROJECT				





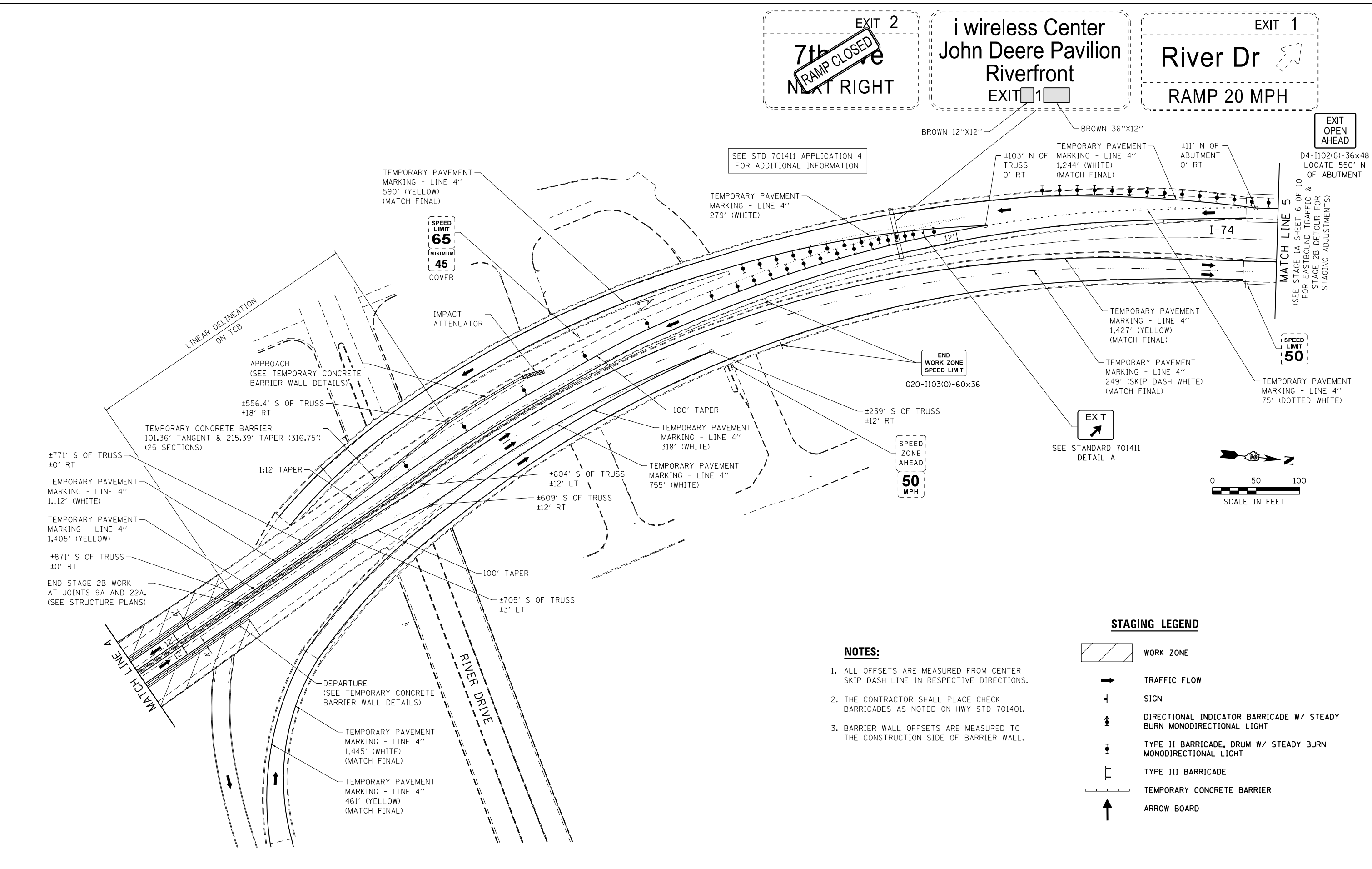





FILE NAME = S:\Projects\2812 Jobs\12-92-09 PTB 164 11 02 1-74 Bridge Repairs-Traffic Control Plans\CADD Sheets\0264H83-sht-Staging-2805.dgn  
 MODEL = Default  
 PLOT DRIVER = 12-92-09\_PDF.plt

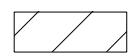

**NOTES:**

1. ALL OFFSETS ARE MEASURED FROM CENTER SKIP DASH LINE IN RESPECTIVE DIRECTIONS.
2. THE CONTRACTOR SHALL PLACE CHECK BARRICADES AS NOTED ON HWY STD 701401.
3. BARRIER WALL OFFSETS ARE MEASURED TO THE CONSTRUCTION SIDE OF BARRIER WALL.

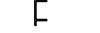
**STAGING LEGEND**

-  WORK ZONE
-  TRAFFIC FLOW
-  SIGN
-  DIRECTIONAL INDICATOR BARRICADE W/ STEADY BURN MONODIRECTIONAL LIGHT
-  TYPE II BARRICADE, DRUM W/ STEADY BURN MONODIRECTIONAL LIGHT
-  TYPE III BARRICADE
-  TEMPORARY CONCRETE BARRIER
-  ARROW BOARD



USER NAME = twalker	DESIGNED - MTM	REVISED -
FILE NAME = 0264H83-sht-Staging-2805.dgn	DRAWN - RG	REVISED -
PLOT SCALE = 100.0000' / 1in.	CHECKED - MCV	REVISED -
PLOT DATE = 8/7/2015	DATE - 7/31/2015	REVISED -

**STATE OF ILLINOIS  
DEPARTMENT OF TRANSPORTATION**

<b>I-74 STAGING PLAN STAGE 2B</b>	
SCALE:	SHEET NO. 3 OF 3 SHEETS STA TO STA

F.A.I. RTE.	SECTION	COUNTY	TOTAL SHEETS	SHEET NO.
74	(81-IHVB & 81-IHVB-1)M-3	ROCK ISLAND	69	41
CONTRACT No. 64H83				
ILLINOIS FED. AID PROJECT				

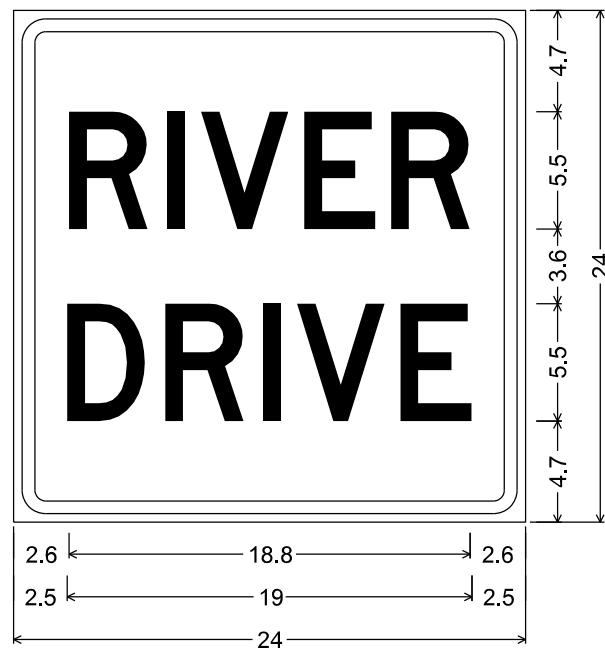

1.5" Radius, 0.6" Border, 0.4" Indent, Black on Orange;  
 [RIVER] D 70% spacing;  
 [DRIVE] D 70% spacing;  
 Table of widths and spaces.

2.6	R	3.7	I	0.9	0.9	0.7	V	4.1	0.7	E	3.4	0.7	R	3.7	2.6
2.5	D	3.7	R	0.9	3.7	0.9	I	0.9	0.7	V	4.1	0.7	E	3.4	2.5

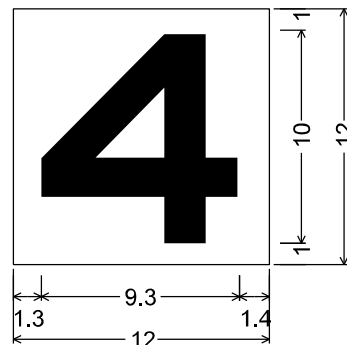

No border, None on Orange;  
 [4] Black Highway E Mod 2K;  
 Table of widths and spaces.

1.3	4	9.3	1.4
-----	---	-----	-----

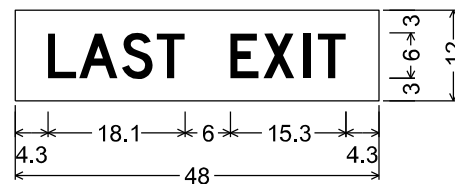

No border, White on Fluorescent orange;  
 [LAST EXIT] Black D 2K 110% spacing;  
 Table of letter and object lefts.

L	A	S	T
4.3	8.5	14.1	18.7
E	X	I	T
28.4	32.8	38.0	39.9

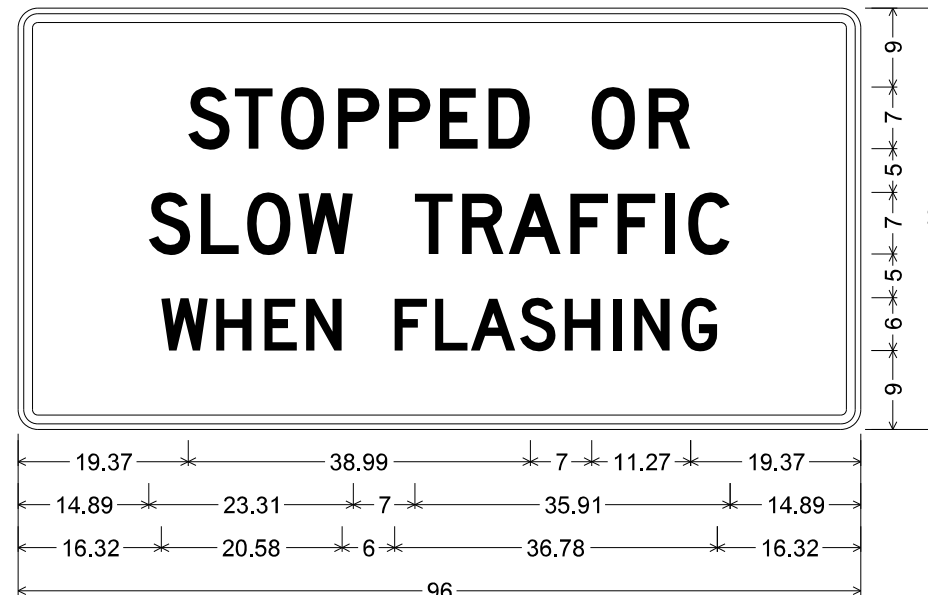

Stopped Or Slow Traffic When Flashing;  
 2.25" Radius, 1.00" Border, 0.63" Indent, Black on Orange;  
 [STOPPED OR] D 2K; [SLOW TRAFFIC] D 2K;  
 [WHEN FLASHING] D 2K;  
 Table of letter and object lefts.

S	T	O	P	P	E	D	O	R		
19.37	24.69	29.94	36.45	42.26	48.07	53.60	65.36	71.87		
S	L	O	W	T	R	A	F	F	I	C
14.89	20.84	26.09	31.97	45.20	50.59	55.91	62.91	68.30	73.69	76.35
W	H	E	N							
16.32	22.56	28.08	32.82							
F	L	A	S	H	I	N	G			
42.90	47.52	51.60	57.18	62.28	67.80	70.20	75.60			

The cost to provide, erect, maintain and remove this sign is included with REAL-TIME TRAFFIC CONTROL CENTRAL BASE UNIT.

The cost to provide, erect, maintain and remove these three signs are included with TRAFFIC CONTROL AND PROTECTION, STANDARD 701451.

FILE NAME = S:\Projects\2012\JOBS\12-02-09\PTB 164 11 02 1-74 Bridge Repairs-Traffic Control Plans\CADD Sheets\0264H83-sht-Staging-Sign Detail.dgn  
 MODEL = Sheet  
 PLOT DRIVER = 12-02-09\_PDF.plt



USER NAME = twalker	DESIGNED - MTM	REVISED -
FILE NAME = D264H83-sht-Staging-Sign Detail.dgn	DRAWN - RG	REVISED -
PLOT SCALE = 300.0000' / in.	CHECKED - MCV	REVISED -
PLOT DATE = 8/7/2015	DATE - 7/31/2015	REVISED -

STATE OF ILLINOIS  
 DEPARTMENT OF TRANSPORTATION

SIGN DETAILS

SCALE: SHEET NO. OF SHEETS STA TO STA

F.A.I. RTE.	SECTION	COUNTY	TOTAL SHEETS	SHEET NO.
74	(81-IHVB & 81-IHVB-1)M-3	ROCK ISLAND	69	42
CONTRACT No. 64H83				
ILLINOIS FED. AID PROJECT				

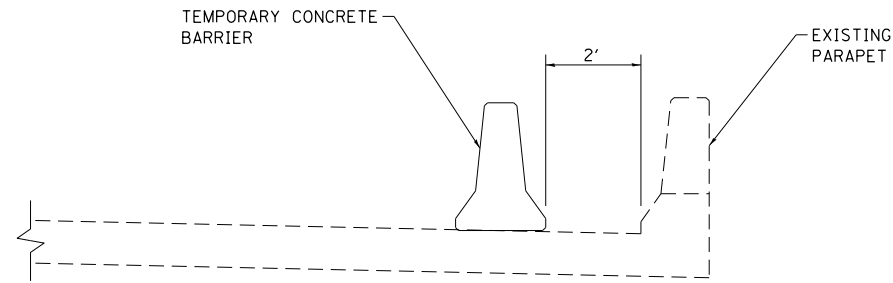

**SECTION A-A**

**NOTES:**

1. THE CONTRACTOR SHALL USE THIS DETAIL TO MINIMIZE OR ELIMINATE PINNING ON BRIDGE DECK.
2. NOT ALL TRAFFIC CONTROL DETAILS (SIGNS, CHANNELIZING DEVICES, ETC.) SHOWN.
3. NO EQUIPMENT OR MATERIALS ARE TO BE STORED WITHIN THE 2' BUFFER AREA BEHIND THE UNPINNED TEMPORARY CONCRETE BARRIER.

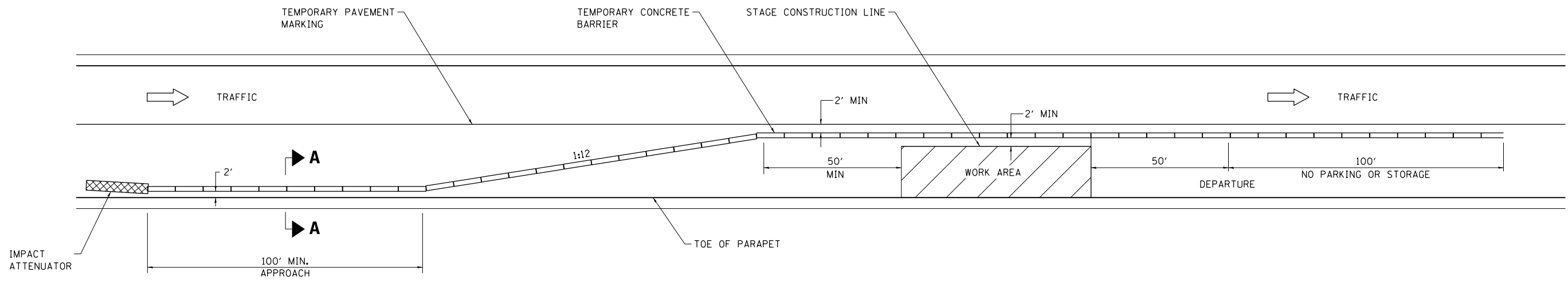

**TEMPORARY CONCRETE BARRIER BRIDGE APPROACH / DEPARTURE DETAIL**

FILE NAME = S:\Projects\2012\JOBS\12-92-09\PTB 164 11 02 1-74 Bridge Repairs-Traffic Control Plans\CADD Sheets\0264H83-sht-DetailBarrier.dgn  
 MODEL = Default  
 PLOT DRIVER = 12-92-09\_PDF.plt



USER NAME = twalker	DESIGNED - MTM	REVISED -
FILE NAME = 0264H83-sht-DetailBarrier.dgn	DRAWN - RG	REVISED -
PLOT SCALE = 40.0000' / in.	CHECKED - MCV	REVISED -
PLOT DATE = 8/7/2015	DATE - 7/31/2015	REVISED -

**STATE OF ILLINOIS**  
**DEPARTMENT OF TRANSPORTATION**

**TEMPORARY CONCRETE BARRIER WALL DETAILS**

SCALE:      SHEET NO.    OF    SHEETS    STA      TO STA

F.A.I. RTE.	SECTION	COUNTY	TOTAL SHEETS	SHEET NO.
74	181-1HVB & 81-1HVB-1M-3	ROCK ISLAND	69	43
CONTRACT No. 64H83				
ILLINOIS FED. AID PROJECT				

# URBAN LANE INSIDE CLOSURE, MULTILANE, 2-WAY, WITH MOUNTABLE MEDIAN

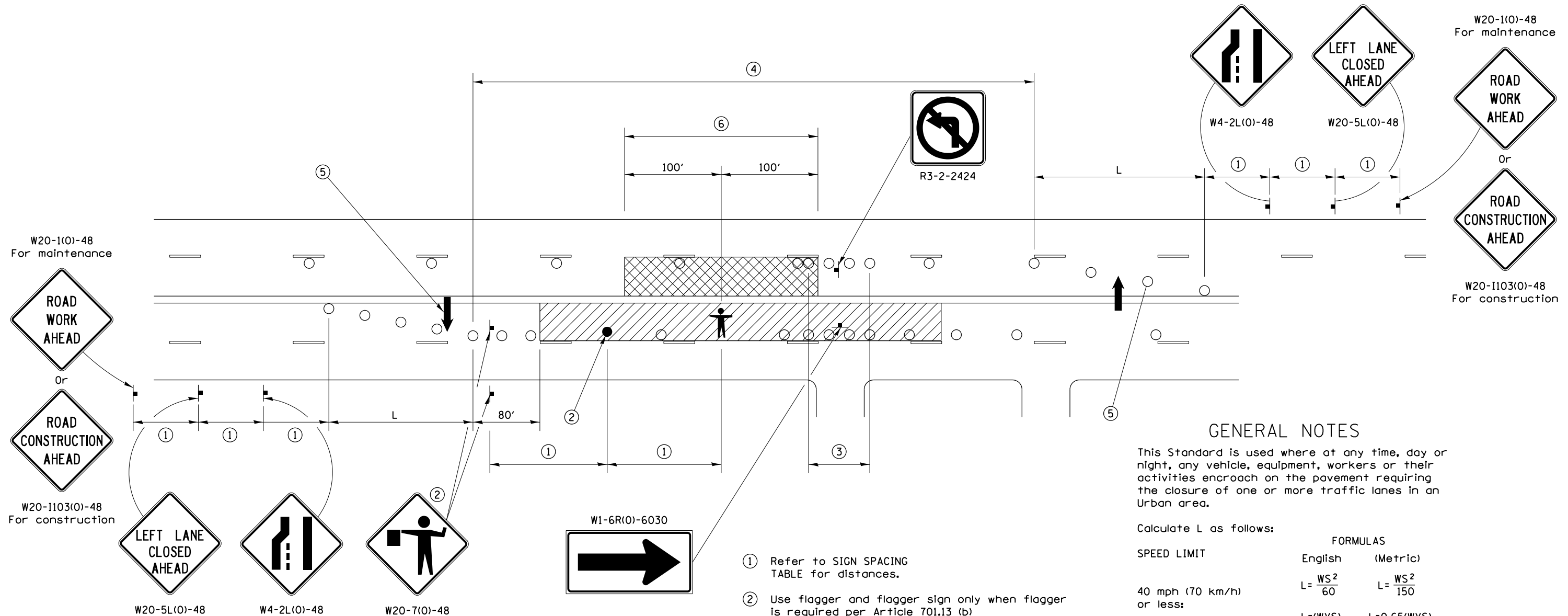

## GENERAL NOTES

This Standard is used where at any time, day or night, any vehicle, equipment, workers or their activities encroach on the pavement requiring the closure of one or more traffic lanes in an Urban area.

Calculate L as follows:

SPEED LIMIT	FORMULAS	
	English	(Metric)
40 mph (70 km/h) or less:	$L = \frac{WS^2}{60}$	$L = \frac{WS^2}{150}$
45 mph (80 km/h) or greater:	$L = (W)(S)$	$L = 0.65(W)(S)$

W = Width of offset in feet (meters).  
S = Normal posted speed mph (km/h).

All dimensions are in inches (millimeters) unless otherwise shown.

Lane closures in the opposite direction shall be removed when no workers are present.

Cones or reflectorized cones shall not be used during hours of darkness.

This Traffic Control detail shall be included in the cost of Traffic Control and Protection Standard 701606.

- ① Refer to SIGN SPACING TABLE for distances.
- ② Use flagger and flagger sign only when flagger is required per Article 701.13 (b)
- ③ Devices at 10' centers from edge of radius return to edge of radius return when left turns are prohibited due to actively working in the intersection
- ④ Cones at 20' (6 m) centers for 250' (75 m). Additional cones may be placed at 40' (12 m) centers. When drums or Type I or Type II barricades are used, the interval between devices may be doubled (excluding devices in intersections).
- ⑤ Cones, drums or barricades at 20' (6 m) centers in taper.
- ⑥ No equipment, materials, vehicles, or other hazards are allowed in the closed lane in the opposite direction within 100' of a worker on foot.

## SYMBOLS

- WORK AREA
- CLOSED LANE
- ARROW BOARD
- SIGN ON PORTABLE OR PERMANENT SUPPORT
- CONE, DRUM OR BARRICADE
- FLAGGER WITH TRAFFIC CONTROL SIGN.
- WORKER ON FOOT

SIGN SPACING	
Posted Speed	Sign Spacing
55	500' (150 m)
50-45	350' (100 m)
<45	200' (60 m)

## URBAN LANE INSIDE CLOSURE, MULTILANE, 2-WAY, WITH MOUNTABLE MEDIAN SHEET 1 OF 1 35.1

FILE NAME = S:\Projects\2012\JOBS\12-02-09\PTB 164 11 02 1-74 Bridge Repairs-Traffic Control Plans\CADD Sheets\0264H83-sht-Details.D2.dgn  
 MODEL = Default  
 PLOT DRIVER = 12-02-09\_PDF.plt



# TYPICAL PAVEMENT MARKINGS

## TYPICAL PAVEMENT MARKING FOR FLUSH MEDIAN AT LEFT TURN LANE

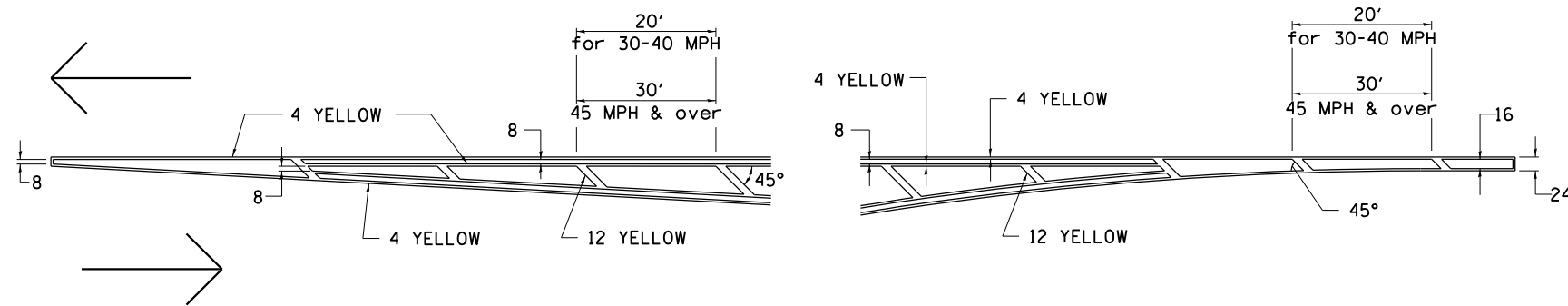

## MEDIAN PAVEMENT MARKING

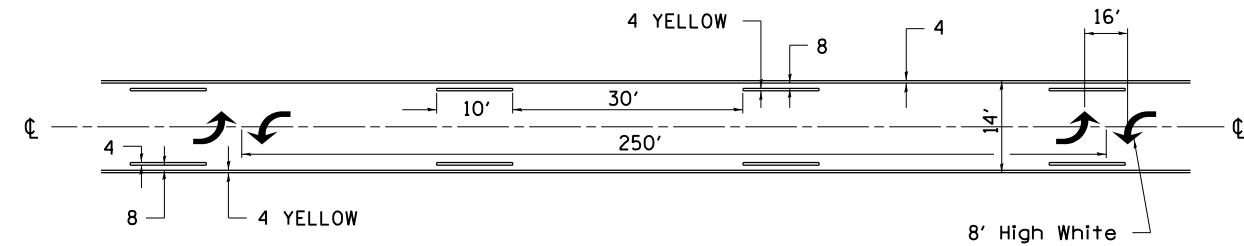

•• ALL DIMENSIONS ARE IN INCHES UNLESS OTHERWISE NOTED.

## TYPICAL ISLAND OFFSET SHOULDER WIDTH

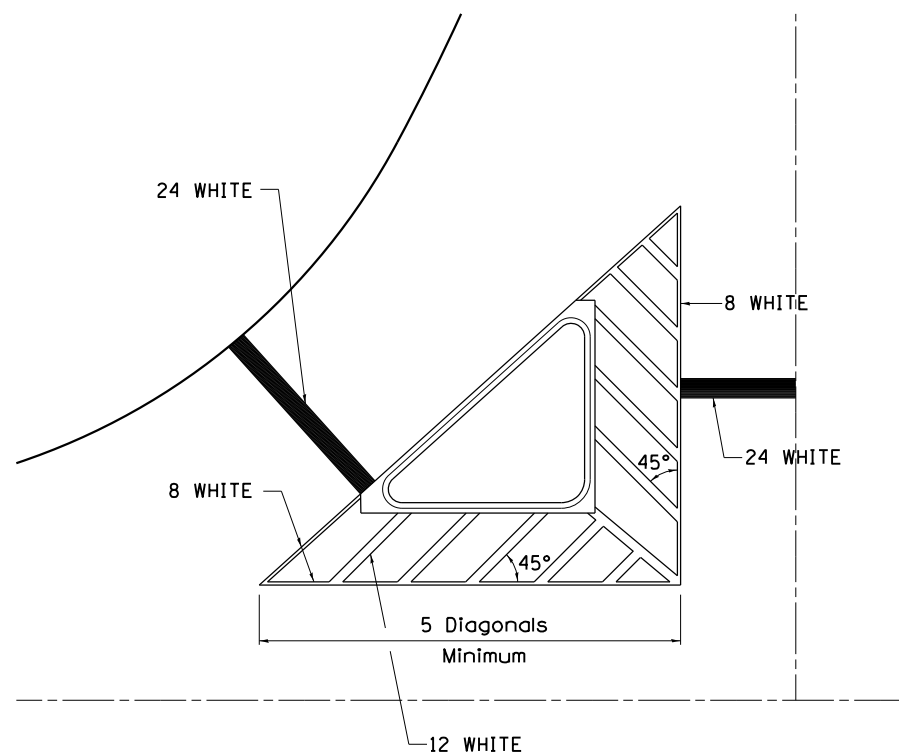

## TYPICAL MARKING FOR PAINTED ISLANDS

NOTE:  
\* 45° TO LOCAL TAN.

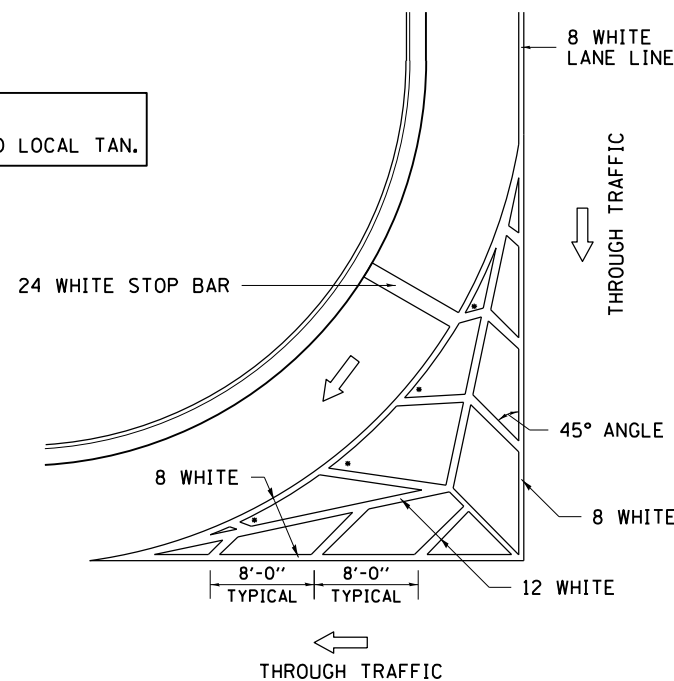

## STANDARD CROSSWALK MARKING

See Schedules for Locations

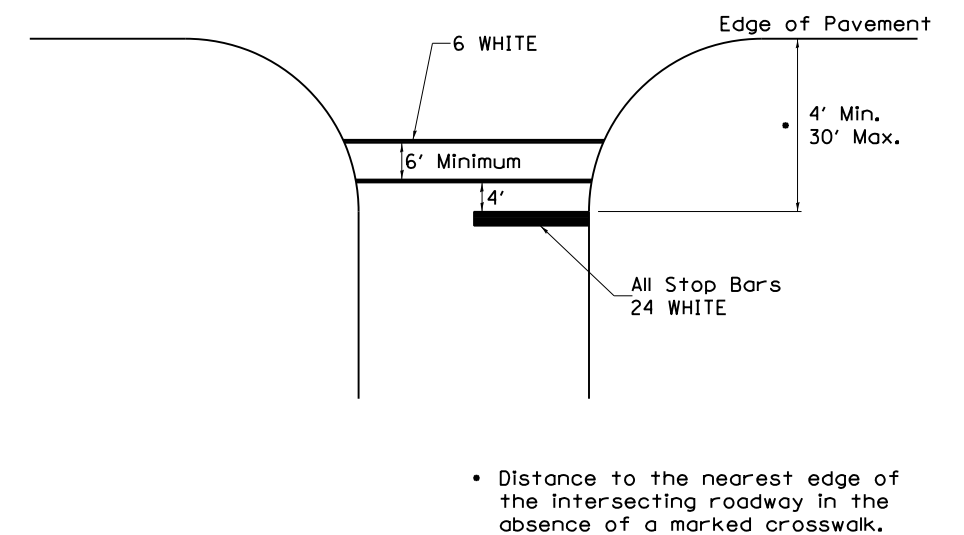

• Distance to the nearest edge of the intersecting roadway in the absence of a marked crosswalk.

# TYPICAL PAVEMENT MARKINGS

## ARROW LAYOUT

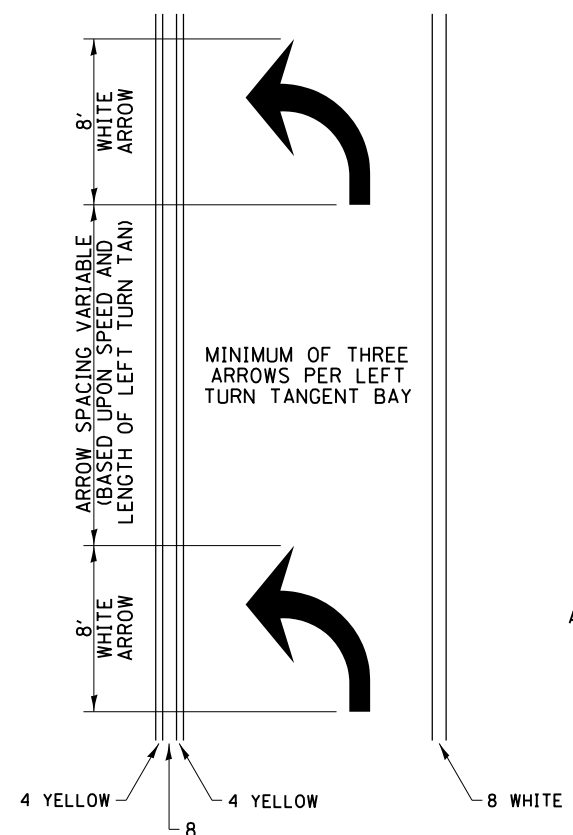

- ◀ ONE-WAY AMBER MARKER
- ◁ ONE-WAY CRYSTAL MARKER
- ◆ TWO-WAY AMBER MARKER

ALL DIMENSIONS ARE IN INCHES UNLESS OTHERWISE NOTED.

## TYPICAL PAVEMENT MARKING FOR FLUSH MEDIAN

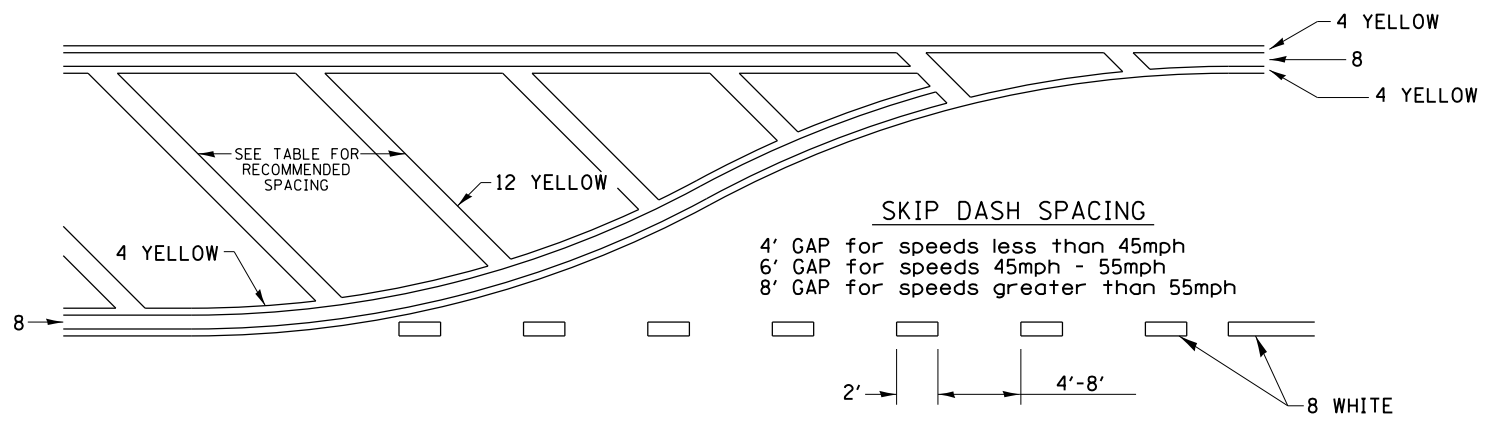

### RECOMMENDED SPACING BETWEEN DIAGONALS (IN FEET)

Speed Limit Range	Continuous Median Area	Intersection Channelization	Objects (Islands)
less than 30MPH	50'	15'	10'
30-40MPH	75'	20'	15'
45MPH & over	75'	30'	20'

NOTE: if the spacing recommended in the Table does not permit at least five diagonal lines in the area being marked, the spacing from the next lowest speed range should be used. The recommended spacing is measured parallel to the pavement center line.

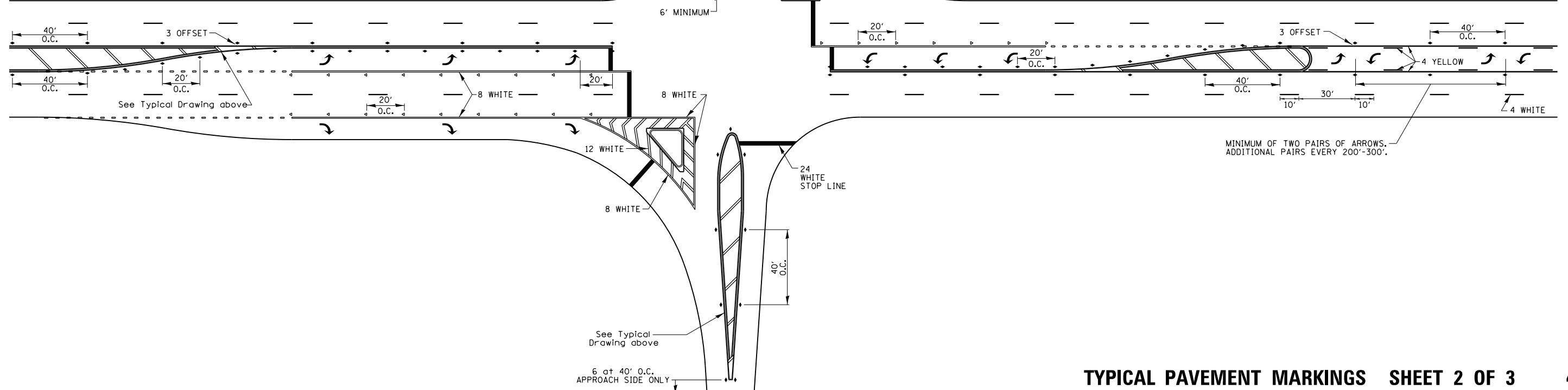

FILE NAME = S:\Projects\2012\JOBS\12-92-09 PTB 164 11 D2 1-74 Bridge Repairs-Traffic Control Plans\CADD\CADD Sheets\0264H83-sht-Details.D2.dgn  
 MODEL = Default  
 PLOT DRIVER = 12-92-09\_PDF.plt



USER NAME = twalker	DESIGNED - MTM	REVISED - 6-27-14
FILE NAME = D264H83-sht-Details.D2.dgn	DRAWN - RG	REVISED - 3-05-12
PLOT SCALE = 10.0000 ' / in.	CHECKED - MCV	REVISED -
PLOT DATE = 8/7/2015	DATE - 7/31/2015	REVISED -

STATE OF ILLINOIS  
DEPARTMENT OF TRANSPORTATION

REGION 2 / DISTRICT 2 STANDARD				
SCALE:	SHEET NO.	OF SHEETS	STA	TO STA

F.A.I. RTE.	SECTION	COUNTY	TOTAL SHEETS	SHEET NO.
74	(81-1HVB & 81-1HVB-1M-3	ROCK ISLAND	69	47
CONTRACT No. 64H83				
ILLINOIS FED. AID PROJECT				

# TYPICAL PAVEMENT MARKINGS

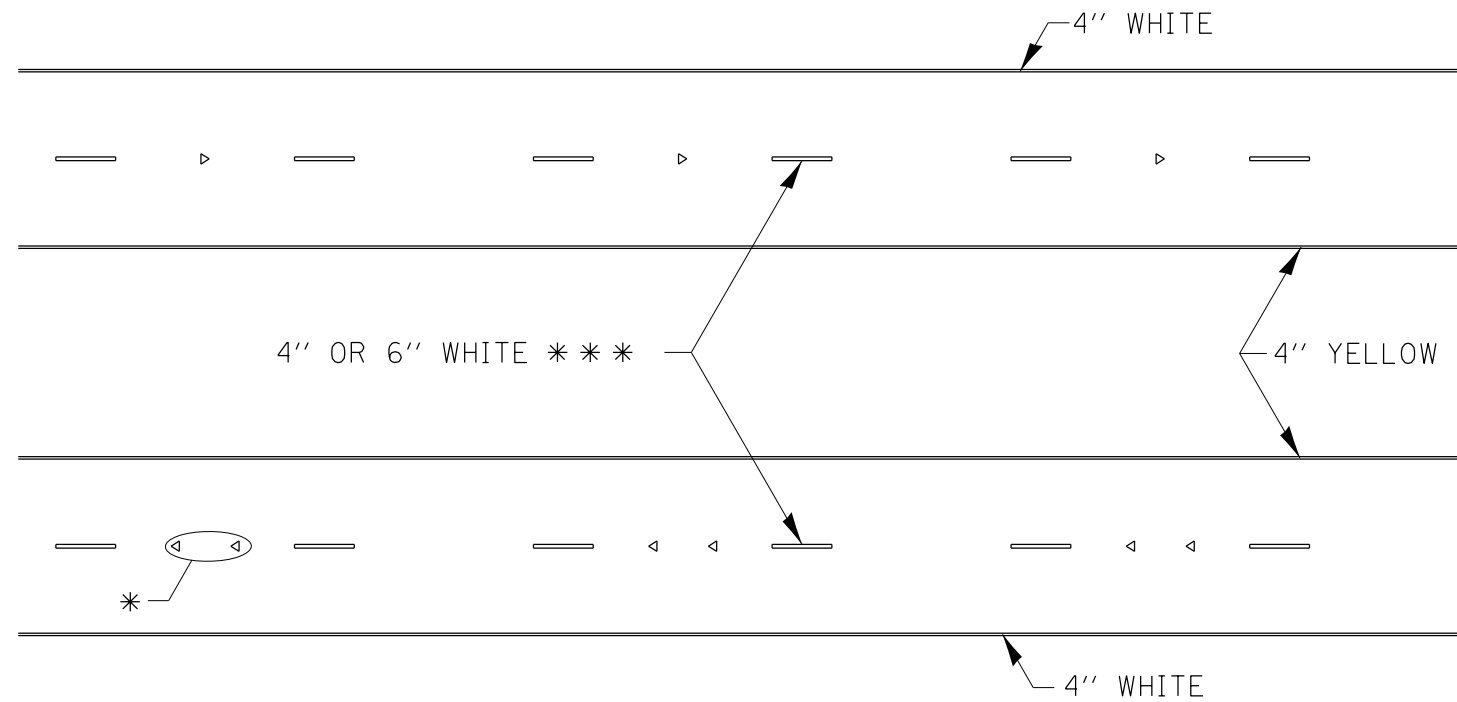

\* SEE HIGHWAY STANDARD 781001 FOR SPACING DETAILS.  
USE DOUBLE MARKERS WHEN ADT > 20,000.

## MULTI-LANE / DIVIDED

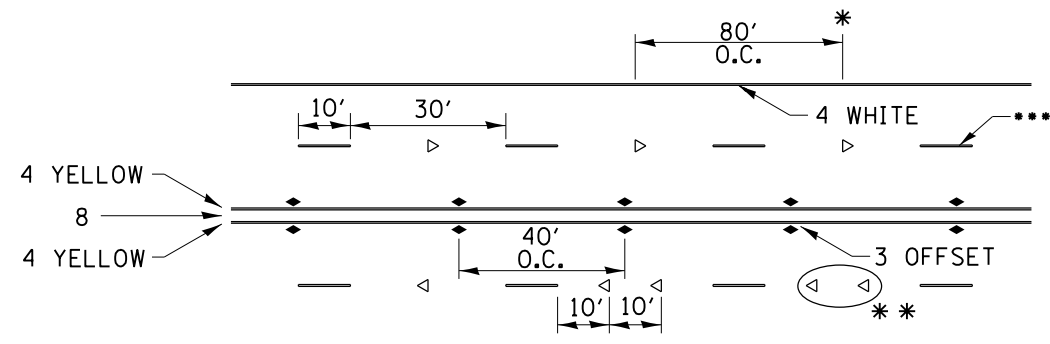

\* REDUCE TO 40' O.C. ON CURVES WHERE ADVISORY SPEEDS ARE 10 MPH LOWER THAN POSTED SPEEDS.

\*\* USE DOUBLE MARKERS WHEN ADT ≥ 20,000

\*\*\* CENTERLINE SKIP DASH PAVEMENT MARKING SPEED LIMIT LESS THAN 40 MPH USE 4" LINE. SPEED LIMIT 40 MPH AND OVER USE 6" LINE.

## MULTI-LANE / UNDIVIDED & ONE WAY

(FOR MULTI-LANE UNDIVIDED HIGHWAYS USE THIS DETAIL NOT HIGHWAY STANDARD 781001)

## TYPICAL PARKING SPACING

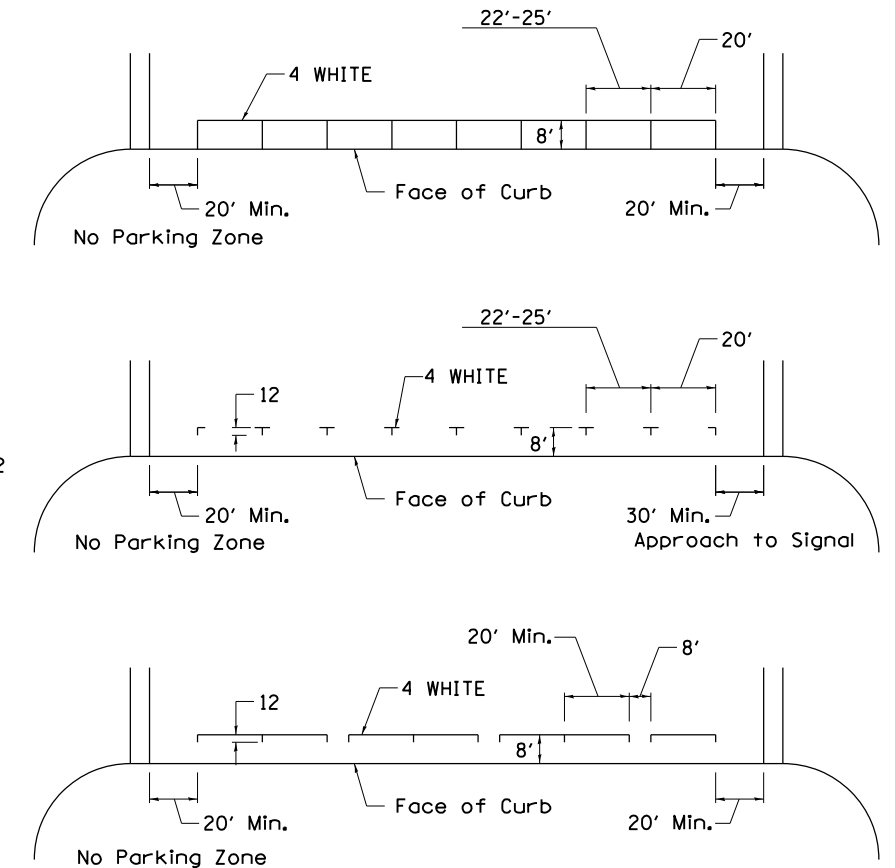

## TYPICAL PAVEMENT MARKING FOR TWO LANE SECTION – NO PASSING ZONES

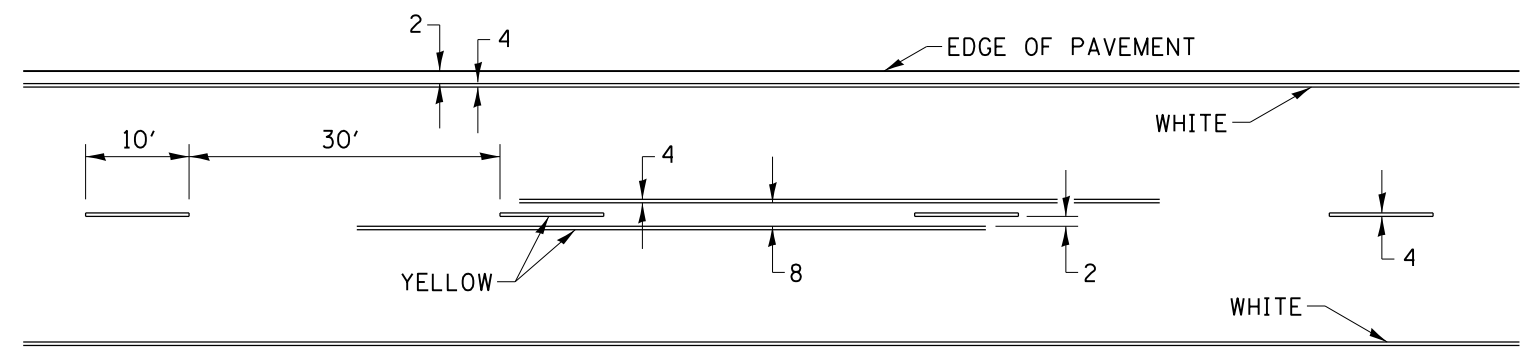

## SYMBOLS



# PAINING DETAILS

CENTERLINE SKIP DASH PAVEMENT MARKING WIDTH SHALL BE 4" WHEN THE POSTED SPEED LIMIT IS UNDER 40 MPH AND 6" WHEN THE POSTED SPEED LIMIT IS 40 MPH AND OVER.

## EXIT RAMP

NOTE: GORE HATCHING PLACED ONLY WHEN SCHEDULED IN THE PLANS

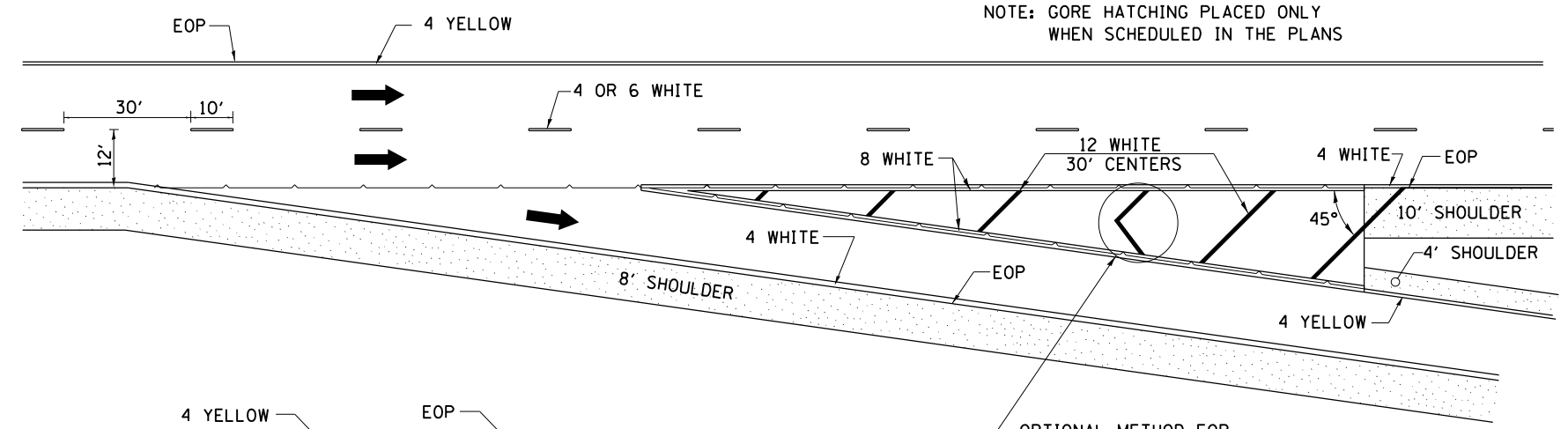

## ENTRANCE RAMP

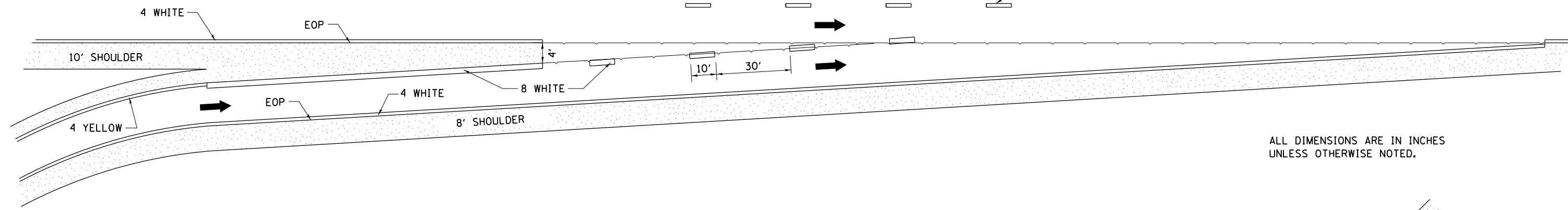

## CLOVERLEAF

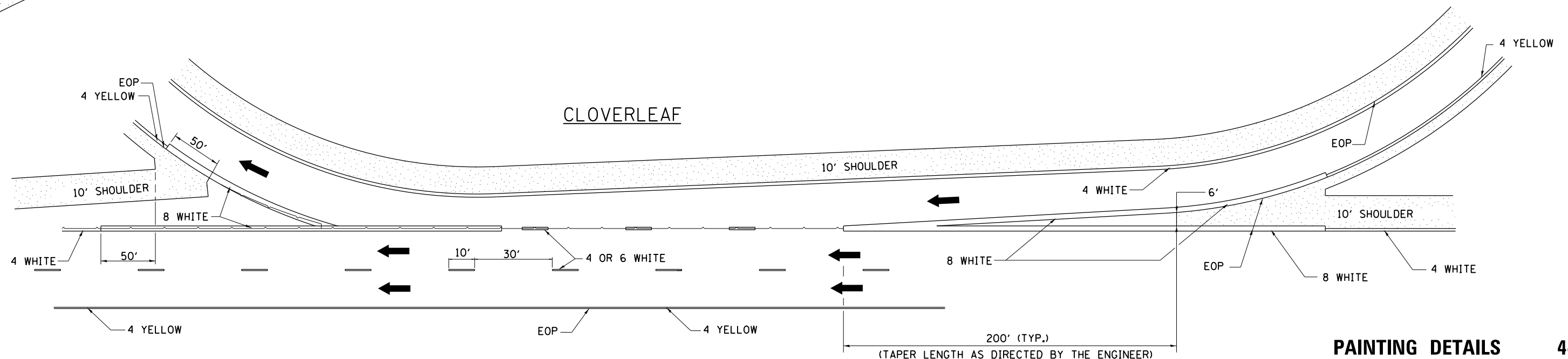

ALL DIMENSIONS ARE IN INCHES UNLESS OTHERWISE NOTED.

## PAINING DETAILS 44.1

FILE NAME = S:\Projects\2012\JOBS\12-92-09\PTB 164 11 02 1-74 Bridge Repairs-Traffic Control Plans\CADD Sheets\0264H83-sht-Details.D2.dgn  
 MODEL = Default  
 PLOT DRIVER = 12-92-09\_PDF.plt



USER NAME = twalker	DESIGNED - MTM	REVISED - 8-27-13
FILE NAME = 0264H83-sht-Details.D2.dgn	DRAWN - RG	REVISED - 10-18-11
PLOT SCALE = 10.0000 ' / in.	CHECKED - MCV	REVISED -
PLOT DATE = 8/7/2015	DATE - 7/31/2015	REVISED -

STATE OF ILLINOIS  
 DEPARTMENT OF TRANSPORTATION

REGION 2 / DISTRICT 2 STANDARD				
SCALE:	SHEET NO.	OF SHEETS	STA	TO STA

F.A.I. RTE.	SECTION	COUNTY	TOTAL SHEETS	SHEET NO.
74	(81-1HVB & 81-1HVB-1M-3	ROCK ISLAND	69	49
CONTRACT No. 64H83				
ILLINOIS FED. AID PROJECT				



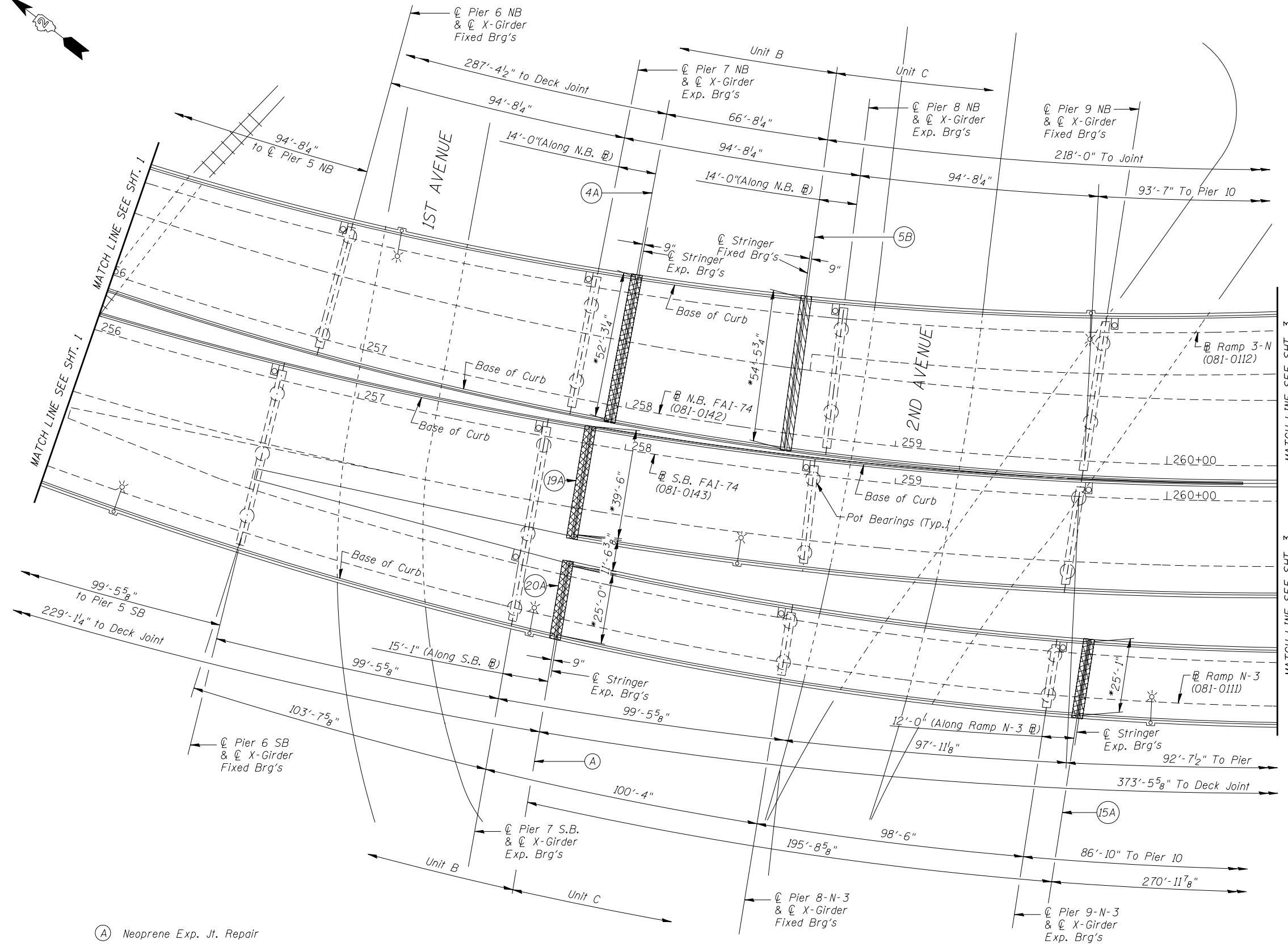
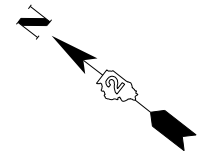

**LEGEND**

- Existing Light
- Existing Floor Drain
- (A)
- (B)
- (A) Neoprene Exp. Jt. Repair
- (B) P.J.S. Jt. Repair
- \* Joint Length given face to face of curb

Note: Dimensions shown are taken from existing plans.

**GENERAL PLAN, UNITS B, C**

FILE NAME = \\Quigg\Projects\Projects\2012\_JOBS\12-92-09\_PTB 164 11 02 1-74 Bridge Repairs-Traffic Control Plans\CADD\CADD Sheets\081-0142-0143-64H83-002-plan02.dgn  
 MODEL = Default  
 PLOT DRIVER = 12-92-09\_PDF.plt



USER NAME =	DESIGNED - MJK	REVISED
	CHECKED - DRB	REVISED
PLOT SCALE =	DRAWN - TRF	REVISED
PLOT DATE =	CHECKED - SCD	REVISED

**STATE OF ILLINOIS  
DEPARTMENT OF TRANSPORTATION**

**GENERAL PLAN UNITS B & C  
STRUCTURE NO. 081-0142 & 081-0143 & 081-0111 & 081-0112**

SHEET NO. 2 OF 20 SHEETS

F.A.I. RTE.	SECTION	COUNTY	TOTAL SHEETS	SHEET NO.
74	(81-IHVB & 81-IHVB-1)M-3	ROCK ISLAND	69	51
				CONTRACT NO. 64H83

ILLINOIS FED. AID PROJECT

FILE NAME = \\Quigg\Projects\Projects\2012\JOBS\12-92-09\PTB 164 11 02 1-74 Bridge Repairs-Traffic Control Plans\CADD Sheets\0810142-0143-64H83-003-plan-03.dgn  
 MODEL = Default  
 PLOT DRIVER = 12-92-09\_PDF.plt

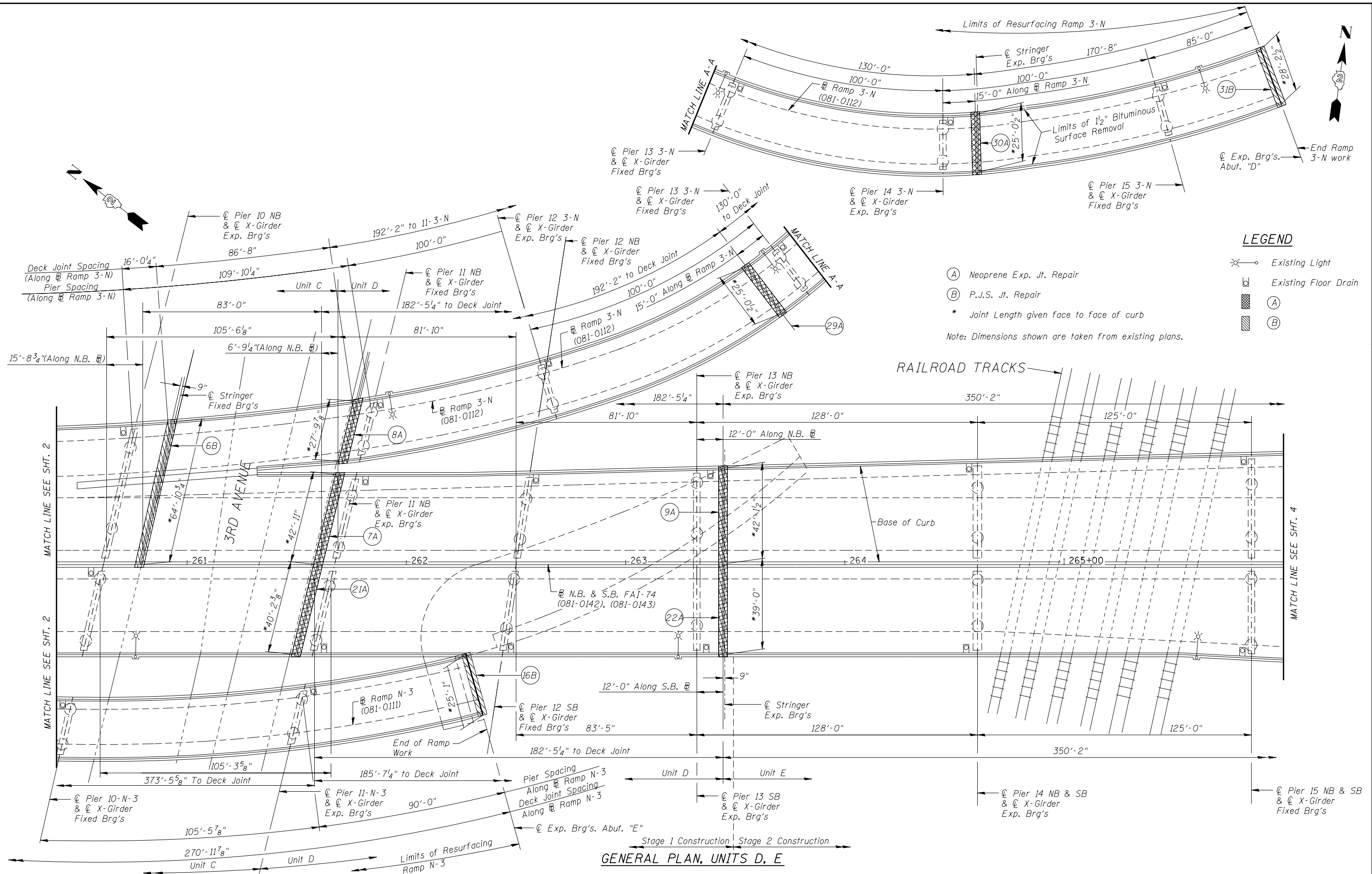

**LEGEND**

- (A) Neoprene Exp. Jt. Repair
  - (B) P.J.S. Jt. Repair
  - \* Joint Length given face to face of curb
  - Existing Light
  - Existing Floor Drain
- Note: Dimensions shown are taken from existing plans.

**GENERAL PLAN, UNITS D, E**



USER NAME =	DESIGNED - MJK	REVISED
	CHECKED - DRB	REVISED
PLOT SCALE =	DRAWN - TRF	REVISED
PLOT DATE	CHECKED - SCD	REVISED

**STATE OF ILLINOIS  
 DEPARTMENT OF TRANSPORTATION**

**GENERAL PLAN UNITS D & E  
 STRUCTURE NO. 081-0142 & 081-0143 & 081-0111 & 081-0112**

SHEET NO. 3 OF 20 SHEETS

F.A.I. RTE.	SECTION	COUNTY	TOTAL SHEETS	SHEET NO.
74	(81-1HVB & 81-1HVB-1M-3)	ROCK ISLAND	69	52
CONTRACT NO. 64H83				
ILLINOIS FED. AID PROJECT				

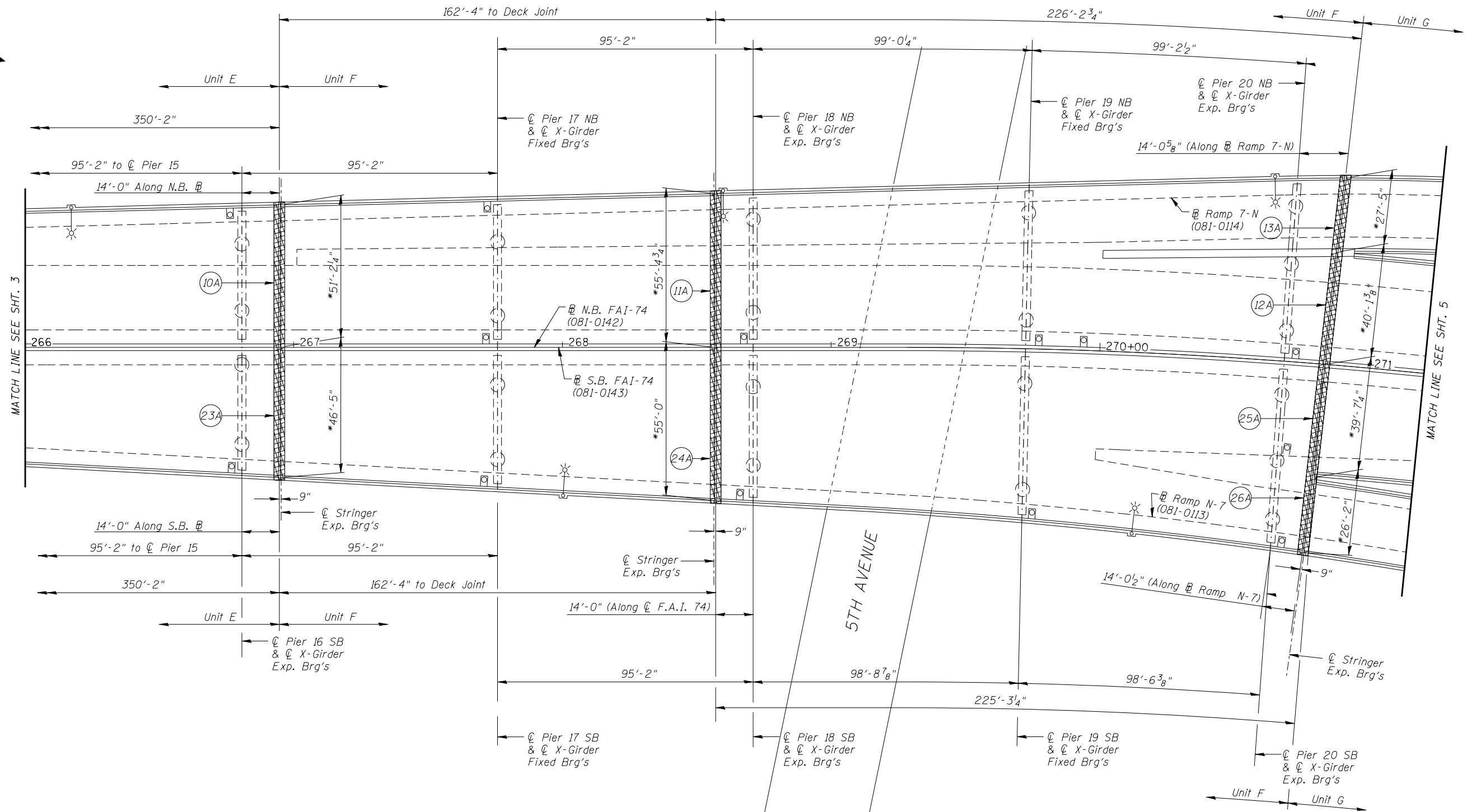
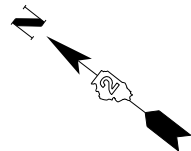

**GENERAL PLAN UNITS F**

**LEGEND**

- Existing Light
  - Existing Floor Drain
  - (A) Neoprene Exp. Jt. Repair
  - (B) P.J.S. Jt. Repair
  - \* Joint Length given face to face of curb
- Note: Dimensions shown are taken from existing plans.

FILE NAME = \\Quigg\Projects\Projects\2012\JOBS\12-92-09\PTB 164 11 02 1-74 Bridge Repairs-Traffic Control\Plans\CADD\Sheet\081-0142-0143-64H83-001-plan04.dgn  
 MODEL = Default  
 PLOT DRIVER = 12-92-09\_PDF.plt



USER NAME =	DESIGNED - MJK	REVISED
	CHECKED - DRB	REVISED
PLOT SCALE =	DRAWN - TRF	REVISED
PLOT DATE =	CHECKED - SCD	REVISED

**STATE OF ILLINOIS  
DEPARTMENT OF TRANSPORTATION**

**GENERAL PLAN UNIT F  
STRUCTURE NO. 081-0142 & 081-0143 & 081-0113 & 081-0114**

SHEET NO. 4 OF 20 SHEETS

F.A.I. RTE.	SECTION	COUNTY	TOTAL SHEETS	SHEET NO.
74	(81-1HVB & 81-1HVB-1)M-3	ROCK ISLAND	69	53
CONTRACT NO. 64H83				

ILLINOIS FED. AID PROJECT

FILE NAME = \\Quigg\Projects\Projects\2012\JOBS\12-92-09\PTB 164 11 02 1-74 Bridge Repairs-Traffic Control\Plans\CADD Sheets\0810142-0143-64H83-005-plan05.dgn  
 MODEL = Default  
 PLOT DRIVER = 12-92-09\_PDF.plt

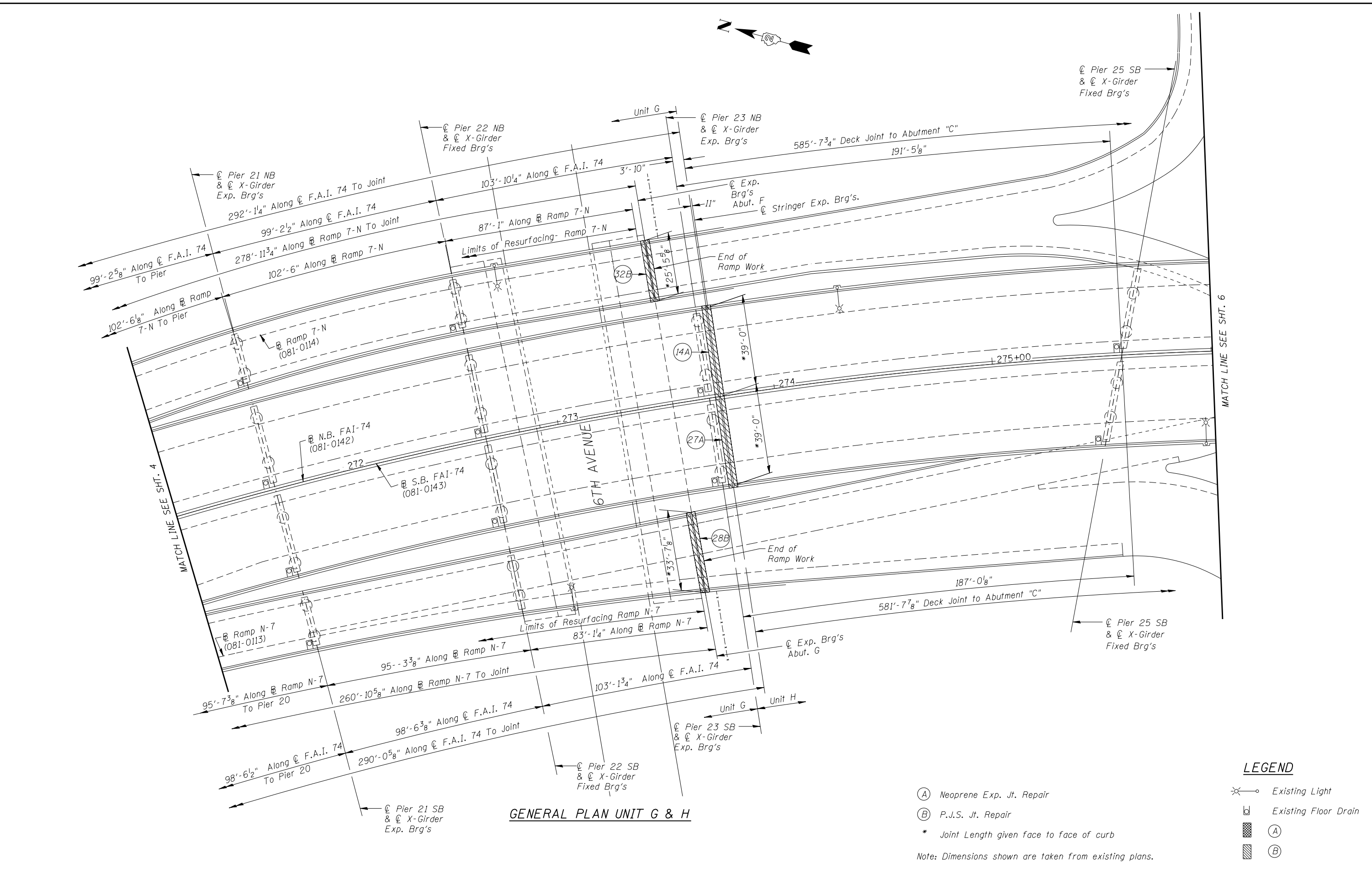

**GENERAL PLAN UNIT G & H**

- LEGEND**
- (A) Neoprene Exp. Jt. Repair
  - (B) P.J.S. Jt. Repair
  - \* Joint Length given face to face of curb
  - Existing Light
  - Existing Floor Drain
  - (A)
  - (B)

Note: Dimensions shown are taken from existing plans.



USER NAME =	DESIGNED - MJK	REVISED
	CHECKED - DRB	REVISED
PLOT SCALE =	DRAWN - TRF	REVISED
PLOT DATE =	CHECKED - SCD	REVISED

**STATE OF ILLINOIS  
 DEPARTMENT OF TRANSPORTATION**

**GENERAL PLAN UNIT G & H  
 STRUCTURE NO. 081-0142 & 081-0143**

SHEET NO. 5 OF 20 SHEETS

F.A.I. RTE.	SECTION	COUNTY	TOTAL SHEETS	SHEET NO.
74	181-1HVB & 81-1HVB-1JM-3	ROCK ISLAND	69	54

CONTRACT NO. 64H83

ILLINOIS FED. AID PROJECT

FILE NAME = \\Quigg\Projects\Projects\2012\JOBS\12-92-09\PTB 164 11 02 1-74 Bridge Repairs-Traffic Control Plans\CADD Sheets\0810142-0143-64H83-006-plan06.dgn  
 MODEL = Default  
 PLOT DRIVER = 12-92-09\_PDF.plt



USER NAME =	DESIGNED - MJK	REVISED
	CHECKED - DRB	REVISED
PLOT SCALE =	DRAWN - TRF	REVISED
PLOT DATE =	CHECKED - SCD	REVISED

STATE OF ILLINOIS  
DEPARTMENT OF TRANSPORTATION

GENERAL PLAN UNIT H  
STRUCTURE NO. 081-0142 & 081-0143

SHEET NO. 6 OF 20 SHEETS

F.A.I. RTE.	SECTION	COUNTY	TOTAL SHEETS	SHEET NO.
74	181-1HVB & 81-1HVB-1JM-3	ROCK ISLAND	69	55
CONTRACT NO. 64H83				
ILLINOIS FED. AID PROJECT				

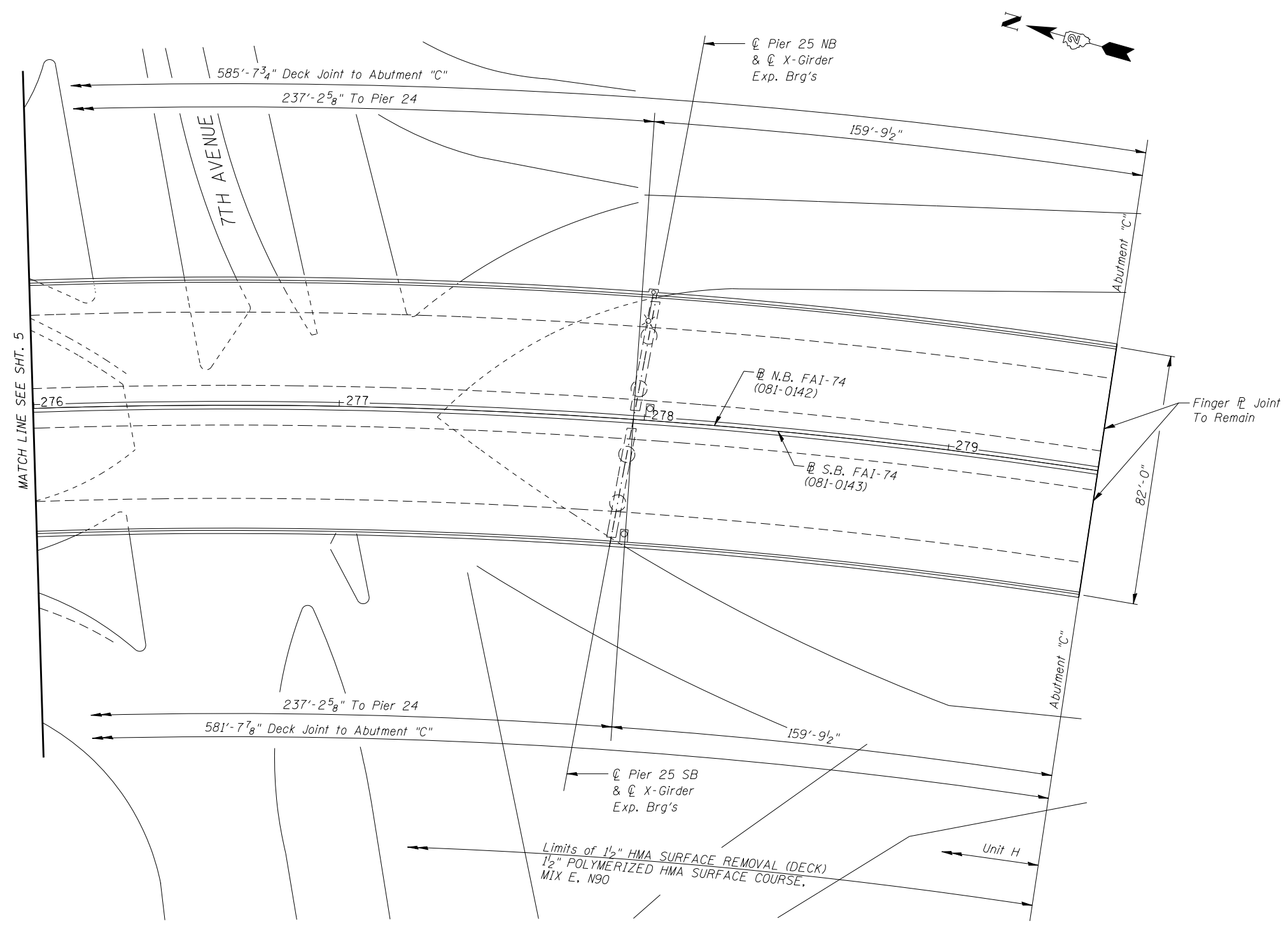

GENERAL PLAN UNIT H

- (A) Neoprene Exp. Jt. Repair
- (B) P.J.S. Jt. Repair

\* Joint Length given face to face of curb

Note: Dimensions shown are taken from existing plans.

LEGEND

- Existing Light
- Existing Floor Drain
- (A)
- (B)

**GENERAL NOTES**

All structural steel shall conform to AASHTO M270, Gr 36 unless otherwise noted.

Fasteners shall be ASTM A325 Type 1, mechanically galvanized bolts. Bolts 7/8"-φ, holes 15/16"-φ, unless otherwise noted.

The existing structural steel contains lead paint. The Contractor shall take appropriate precautions to deal with the presence of lead on this project.

Existing structural steel shall only be cleaned and painted as required at locations shown by the Special Provision "Cleaning and Painting Existing Structural Steel." Cost of Cleaning and Painting Existing Steel shall not be paid for separately, but shall be included in the cost for STRUCTURAL STEEL REPAIR.

Removal of existing joints shall be included in the cost of NEOPRENE EXPANSION JOINT or PREFORMED JOINT SEAL of the size specified as appropriate.

Plan dimensions and details relative to existing structures, have been taken from existing plans and are subject to nominal construction variations. It shall be the Contractor's responsibility to verify such dimensions and details in the field and make necessary approved adjustments prior to construction or ordering of materials. Such variations shall not be cause for additional compensation for a change in the scope of the work, however, the Contractor will be paid for the quantity actually furnished at the unit price bid for the work.

The Contractor shall be responsible for protecting utility and private property during construction operations as outlined in Article 107.26 of the Standard Specifications. The JULIE number is 800-892-0123. These utilities located within the project limits or immediately adjacent to the project construction limits are members of JULIE.

The millings from Bituminous Surface Removal shall become the property of the Contractor.

The SSPC-QP1 and SSPC-QP2 Painting Contractor certifications will not be required for this bridge.

All new structural steel shall be shop painted with the inorganic zinc rich primer per AASHTO M 300, Type 1. Cost included with STRUCTURAL STEEL REPAIR.

Existing structural steel that will be in contact with new structural steel shall be cleaned and painted prior to erection as required by the special provision "Cleaning and Painting Existing Steel Structures".

The designated areas cleaned per Near White Blast Cleaning - SSPC-SP10 and per Power Tool Cleaned - Commercial Grade shall be painted according to the requirements of Paint System 1 - OZ/E/U. The color of the final finish coat shall be Interstate Green, Munsell No 7.5G 4/8.

A minimum of four air monitors will be required to monitor abrasive blasting operations at this site, see special provision for "Containment and Disposal of Lead Paint Cleaning Residues." Cost of Containment and Disposal of Lead Paint Cleaning Residues included in STRUCTURAL STEEL REPAIR.

A nominal quantity of POLYMER MODIFIED PORTLAND CEMENT MORTAR has been included for the repair of concrete blockouts around expansion joints where required.

Nominal quantities of DECK SLAB REPAIR (FULL DEPTH, TYPE I); DECK SLAB REPAIR (FULL DEPTH, TYPE II); and DECK SLAB REPAIR (PARTIAL) are included in the Bill of Material. The actual quantity will be determined in the field following removal of the existing surface course and waterproofing membrane.

The quantity of PROTECTIVE SHIELD is based on the following schedule:

RR Between P4 & P5	1170 SQ YD
1st Ave	540 SQ YD
2nd Ave	540 SQ YD
3rd Ave	620 SQ YD
Ramp N3	560 SQ YD
RR Between P14 & P15	1200 SQ YD
5th Ave	540 SQ YD
6th Ave	100 SQ YD
7th Ave	2270 SQ YD
<b>Total</b>	<b>8440 SQ YD</b>

Protective shield shall be installed as needed to protect pedestrian, vehicular, and railroad traffic from falling objects. In spans, or portions of spans, where there is no full depth deck repair and no other potential for falling objects in the opinion of the Engineer, the Protective Shield for that area shall be deleted from the contract.

**INDEX OF SHEETS**

- 1 General Plan Units A & B
- 2 General Plan Units B & C
- 3 General Plan Units D & E
- 4 General Plan Unit F
- 5 General Plan Units G & H
- 6 General Plan Unit H
- 7 General Notes & Bill of Material
- 8 Typical Sections
- 9 Joint Location Plan
- 10 Joint Details
- 11 Crack Repair Girder 279 Detail A
- 12 Crack Repair Girder 103 Detail B
- 13 Crack Repair Girder 9 Detail C
- 14 Crack Repair Btwn G31 & G32 Detail D
- 15 Crack Repair Girder 223 Detail E
- 16 Crack Repair Girder 242 Detail F
- 17 Crack Repair Girder 266 Details G & H
- 18 Temporary Concrete Barrier for Stage Construction
- 19 Slopewall Repair - Abutment "E"
- 20 Slopewall Repair - 6th Ave.

**MAJOR ITEMS OF WORK**

1. Remove and replace neoprene joints with new neoprene joints of the size shown on the plans. No concrete modifications required.
2. Remove and replace preformed joint seals with new preformed joint seals of the size shown on the plans. No concrete modifications required.
3. Provide crack repair remedial measures at longitudinal girders and cross girder joints as shown on plans.
4. Full and partial depth repair of existing concrete deck.
5. Repair slope walls at Abut. 'E' and each side of 6th Ave. in accordance to the details shown on plans.
6. Remove existing HMA Surface Course and replace with new HMA Surface Course

**TOTAL BILL OF MATERIAL**

Item	Unit	Total
Slope Wall Removal	Sq Yd	89
Slope Wall 4 Inch	Sq Yd	89
Slope Wall Crack Sealing	Foot	1,924
Downspout Connection	Each	1
Preformed Joint Seal 1 3/4"	Foot	122
Preformed Joint Seal 2 1/2"	Foot	119
Neoprene Expansion Joint 2"	Foot	28
Neoprene Expansion Joint 2 1/2"	Foot	645
Neoprene Expansion Joint 4"	Foot	374
Polymer Modified Portland Cement Mortar	Cu Ft	25
Structural Steel Repair	L Sum	1
Hot-Mix Asphalt Surface Removal (Deck)	Sq Yd	32,880
Deck Slab Repair (Full Depth, Type I)	Sq Yd	1,101
Deck Slab Repair (Full Depth, Type II)	Sq Yd	543
Deck Slab Repair (Partial)	Sq Yd	3,288
Protective Shield	Sq Yd	8,440
Polymerized Hot-Mix Asphalt Surface Course, Mix E, N90	Ton	2,935
Polymerized Bituminous Materials (Prime Coat)	Pound	14,796

**DESIGN SPECIFICATIONS**

2002 AASHTO Standard Specifications for Highway Bridges, 17th Edition

**DESIGN STRESSES**

FIELD UNITS (New Construction)

f'c = 4,000 psi  
 fy = 60,000 psi (Reinforcement)  
 fy = 36,000 psi (M270 Gr.36)

FIELD UNITS (Existing Construction)

fc = 1,200 psi (Slab)  
 fc = 1,400 psi (Curb & Parapet)  
 fc = 1,000 psi (Substructure)  
 fs = 20,000 psi (Reinforcement Bars & Structural Steel), (A-36)  
 n = 10  
 Allowable LL Deflection L/1200 (Composite Construction Thru out).

**LOADING**

HS20-44 and alternate military loading.

FILE NAME = \\duigg\Projects\Projects\2012\JOBS\12-92-09\PTB 164 11 02 1-74 Bridge Repairs-Traffic Control Plans\CADD\Sheet\0810142-0143-64H83-007-generalnotes.dgn  
 MODEL = Default  
 PLOT DRIVER = 12-92-091.PDF.plt



USER NAME =	DESIGNED - MJK	REVISED
	CHECKED - DRB	REVISED
PLOT SCALE =	DRAWN - TRF	REVISED
PLOT DATE =	CHECKED - SCD	REVISED

**STATE OF ILLINOIS  
 DEPARTMENT OF TRANSPORTATION**

**GENERAL NOTES & BILL OF MATERIALS**

SHEET NO. 7 OF 20 SHEETS

F.A.I. RTE.	SECTION	COUNTY	TOTAL SHEETS	SHEET NO.
74	(81-IHVB & 81-IHVB-1)M-3	ROCK ISLAND	69	56
<b>CONTRACT NO. 64H83</b>				
ILLINOIS FED. AID PROJECT				



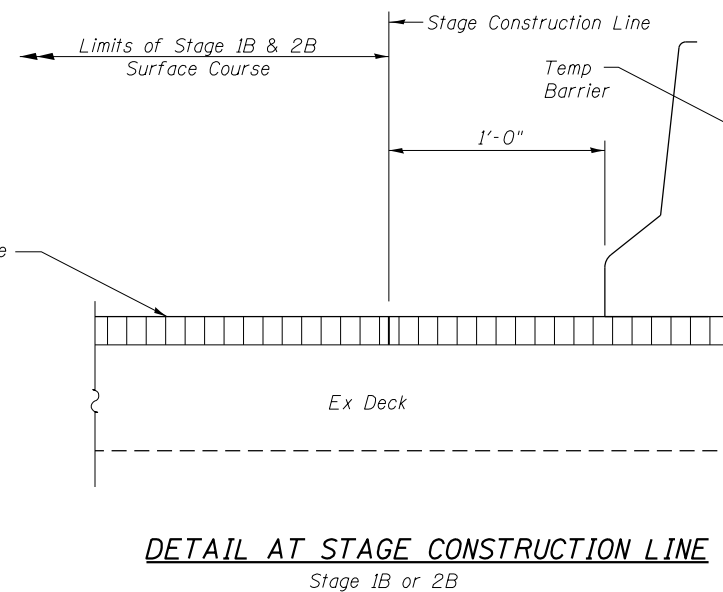
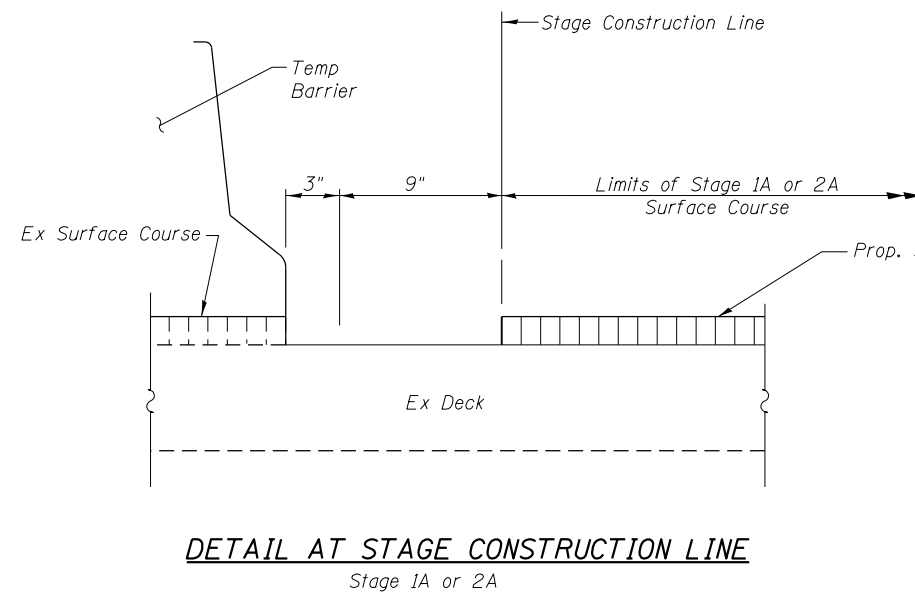
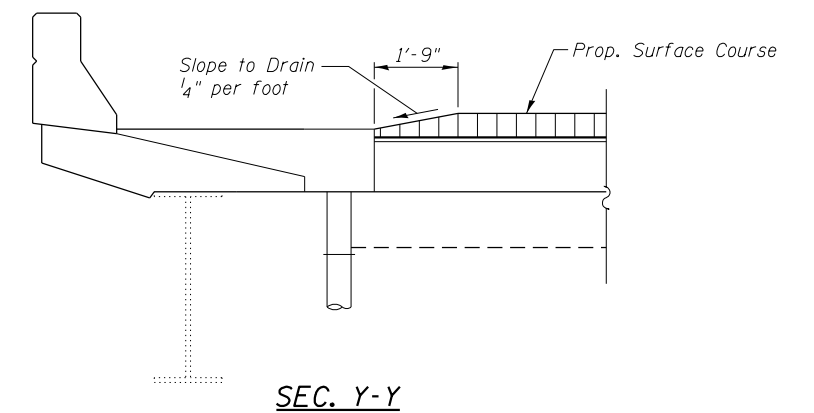
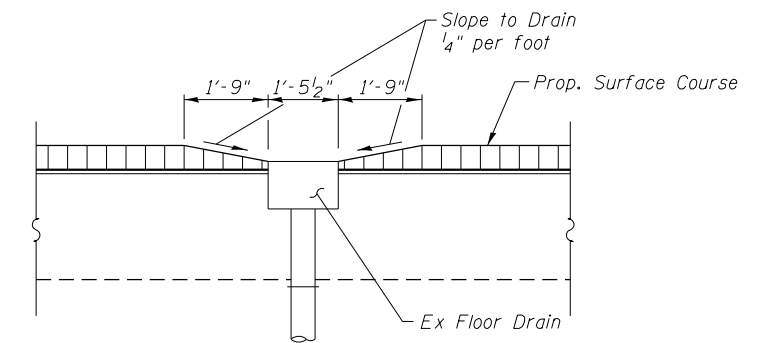
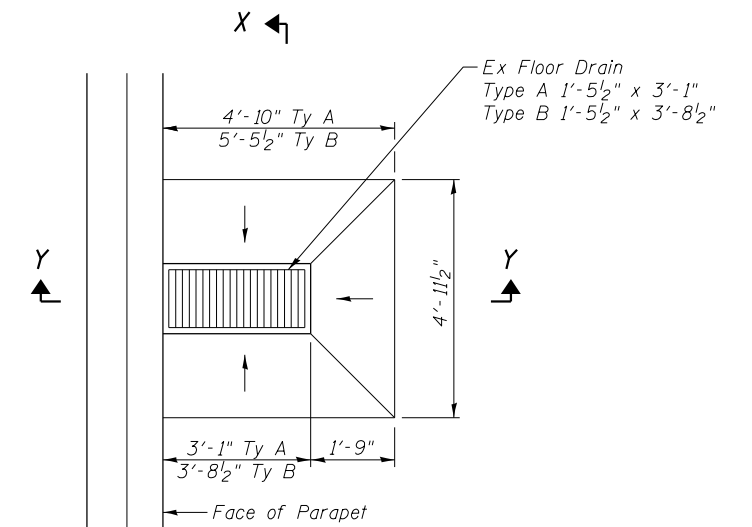
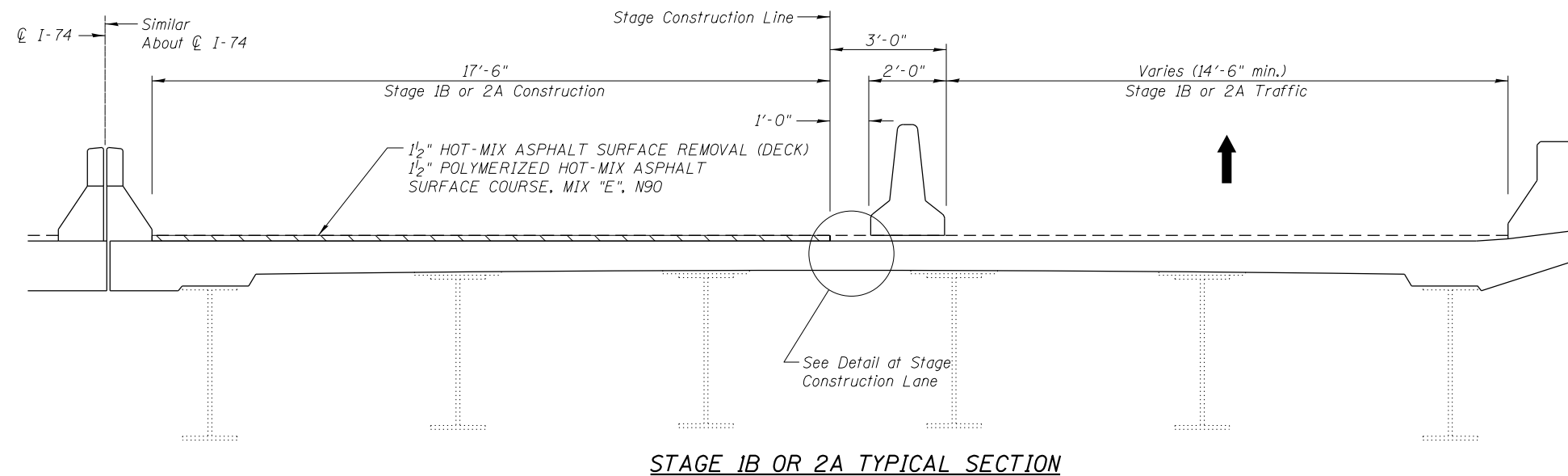
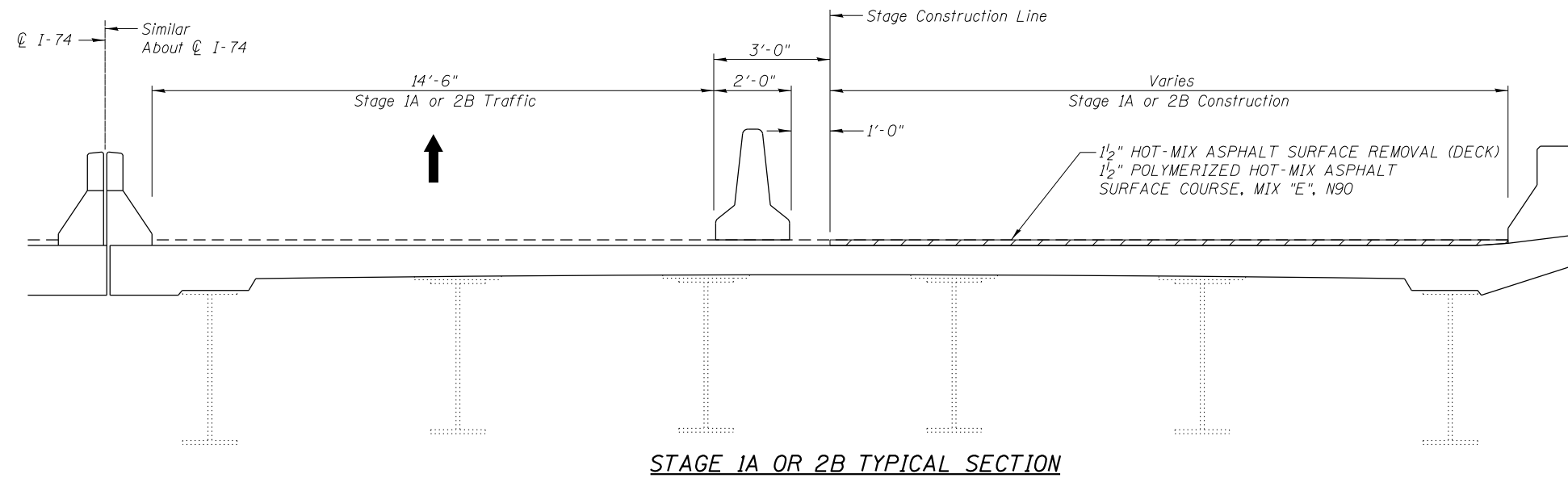

FILE NAME = \\Quigg\Projects\Projects\2012\JOBS\12-92-09\PTB 164 11 02 1-74 Bridge Repairs-Traffic Control Plans\CADD\CADD Sheets\0810142-0143-64H83-008-typical.dgn  
MODEL = Default  
PLOT DRIVER = 12-92-09\_PDF.plt



USER NAME =	DESIGNED - MJK	REVISED
	CHECKED - DRB	REVISED
PLOT SCALE =	DRAWN - TRF	REVISED
PLOT DATE =	CHECKED - SCD	REVISED

STATE OF ILLINOIS  
DEPARTMENT OF TRANSPORTATION

TYPICAL SECTIONS

SHEET NO. 8 OF 20 SHEETS

F.A.I. RTE.	SECTION	COUNTY	TOTAL SHEETS	SHEET NO.
74	(81-1HVB & 81-1HVB-1)M-3	ROCK ISLAND	69	57
CONTRACT NO. 64H83				
ILLINOIS FED. AID PROJECT				

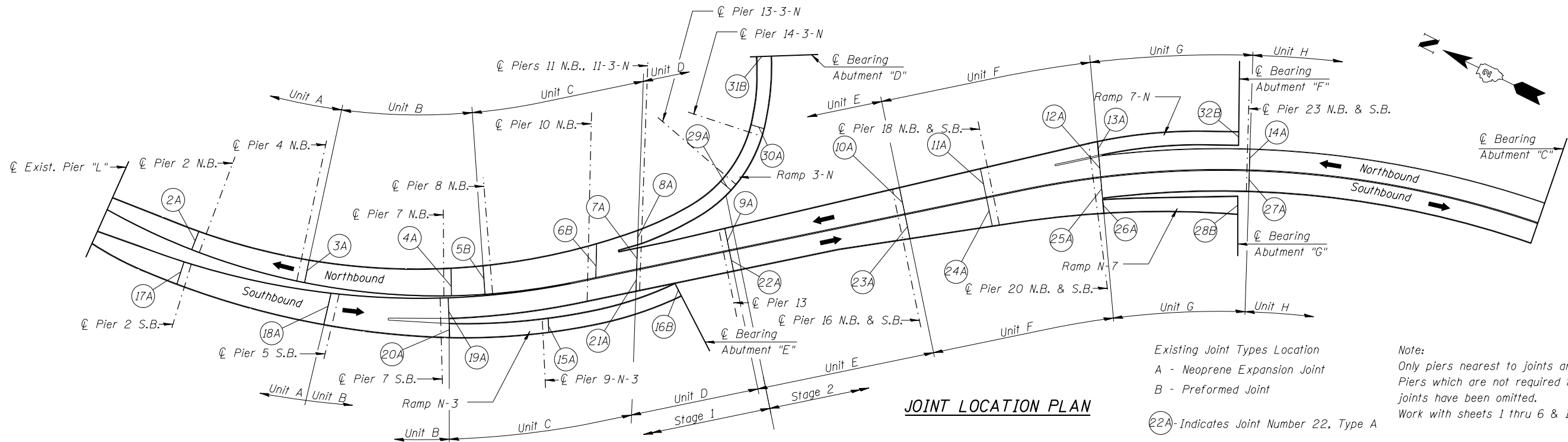

**STAGE 1: EXPANSION JOINT DIMENSIONS**

JOINT NUMBER	LANE	NEAREST SUBSTR UNIT	JOINT TYPE	OPENING @ 50* F (INCH)	JOINT LENGTH FACE OF CURB TO FACE OF CURB (FOOT)	STAGE 1A DIMENSION CURB TO STAGE CONST. (FOOT)	STAGE 1B DIMENSION CURB TO STAGE CONST. (FOOT)	ADD CURB PIECE (FOOT)	PAY LIMITS NEOPRENE 2" LENGTH (FOOT)	PAY LIMITS NEOPRENE 2.5" LENGTH (FOOT)	PAY LIMITS NEOPRENE 4" LENGTH (FOOT)	PAY LIMITS PJS 1.75" LENGTH (FOOT)	PAY LIMITS PJS 2.5" LENGTH (FOOT)
2A	NB	PIER 2	NEOPRENE	2.5	36.85	19.35	17.50	2		39			
3A	NB	PIER 4	NEOPRENE	3	43.38	25.88	17.50	2			46		
4A	NB	PIER 7	NEOPRENE	3	52.27	34.77	17.50	2			55		
5B	NB	PIER 8	PJS	1	54.48	36.98	17.50	1				56	
6B	NB	PIER 10	PJS	1	64.90	47.40	17.50	1				66	
7A	NB	PIER 11	NEOPRENE	2.5	42.92	25.42	17.50	2		45			
8A	RAMP	PIER 11	NEOPRENE	2.5	27.82	27.82		2		30			
9A	NB	PIER 13	NEOPRENE	3	42.13	24.63	17.50	2			45		
15A	RAMP	PIER 9	NEOPRENE	2	25.08	25.08		2	28				
16B	RAMP	ABUT E	PJS	1.75	25.08	25.08		1					27
17A	SB	PIER 2	NEOPRENE	2.5	43.71	26.21	17.50	2		46			
18A	SB	PIER 5	NEOPRENE	3	60.79	43.29	17.50	2			63		
19A	SB	PIER 7	NEOPRENE	3	39.50	22.00	17.50	2			42		
20A	RAMP	PIER 7	NEOPRENE	2.5	25.00	25.00		2		27			
21A	SB	PIER 11	NEOPRENE	2.5	40.20	22.70	17.50	2		43			
22A	SB	PIER 13	NEOPRENE	3	39.00	21.50	17.50	2			41		
29A	RAMP	PIER 13	NEOPRENE	2.5	25.04	25.04		2		28			
30A	RAMP	PIER 14	NEOPRENE	2.5	25.04	25.04		2		28			
31B	RAMP	ABUT D	PJS	1.75	28.21	28.21		1					30
<b>SUB TOTAL</b>									<b>28</b>	<b>286</b>	<b>292</b>	<b>122</b>	<b>57</b>

**STAGE 2: EXPANSION JOINT DIMENSIONS**

JOINT NUMBER	LANE	NEAREST SUBSTR UNIT	JOINT TYPE	OPENING @ 50* F (INCH)	JOINT LENGTH FACE OF CURB TO FACE OF CURB (FOOT)	STAGE 2B DIMENSION CURB TO STAGE CONST. (FOOT)	STAGE 2A DIMENSION CURB TO STAGE CONST. (FOOT)	ADD CURB PIECE (FOOT)	PAY LIMITS NEOPRENE 2" LENGTH (FOOT)	PAY LIMITS NEOPRENE 2.5" LENGTH (FOOT)	PAY LIMITS NEOPRENE 4" LENGTH (FOOT)	PAY LIMITS PJS 1.75" LENGTH (FOOT)	PAY LIMITS PJS 2.5" LENGTH (FOOT)
10A	NB	PIER 16	NEOPRENE	2.5	51.19	33.69	17.50	2		54			
11A	NB	PIER 18	NEOPRENE	2.5	55.40	37.90	17.50	2		58			
12A	NB	PIER 20	NEOPRENE	2.5	40.11	22.61	17.50			41			
13A	RAMP	PIER 20	NEOPRENE	2.5	27.42	27.42		1		29			
14A	NB	PIER 23	NEOPRENE	3	39.00	21.50	17.50	2			41		
23A	SB	PIER 16	NEOPRENE	2.5	46.42	28.92	17.50	2		49			
24A	SB	PIER 18	NEOPRENE	2.5	55.00	37.50	17.50	2		57			
25A	SB	PIER 20	NEOPRENE	2.5	39.60	22.10	17.50	2		42			
26A	RAMP	PIER 20	NEOPRENE	2.5	26.17	26.17		2		29			
27A	SB	PIER 23	NEOPRENE	3	39.00	21.50	17.50	2			41		
28B	RAMP	ABUT G	PJS	1.75	33.59	33.59		1					35
32B	RAMP	ABUT F	PJS	1.75	25.47	25.47		1					27
<b>SUBTOTAL</b>									<b>0</b>	<b>359</b>	<b>82</b>	<b>0</b>	<b>62</b>
<b>TOTALS</b>									<b>28</b>	<b>645</b>	<b>374</b>	<b>122</b>	<b>119</b>

FILE NAME = \\Quigg\Projects\Projects\2012\JOBS\12-92-09\PTB 164 11 02 1-74 Bridge Repairs-Traffic Control Plans\CADD\CADD Sheets\0810142-0143-64H83-003-exp\_Location.dgn  
 MODEL = Default  
 PLOT DRIVER = 12-92-09-PTB-164-11-02-1-74 Bridge Repairs-Traffic Control Plans\CADD\CADD Sheets\0810142-0143-64H83-003-exp\_Location.dgn



USER NAME =	DESIGNED - MJK	REVISED
	CHECKED - DRB	REVISED
PLOT SCALE =	DRAWN - TRF	REVISED
PLOT DATE	CHECKED - SCD	REVISED

**STATE OF ILLINOIS  
DEPARTMENT OF TRANSPORTATION**

**JOINT LOCATION PLAN**

SHEET NO. 9 OF 20 SHEETS

F.A.I. RTE.	SECTION	COUNTY	TOTAL SHEETS	SHEET NO.
74	(81-IHVB & 81-IHVB-1)M-3	ROCK ISLAND	69	58
CONTRACT NO. 64H83				
ILLINOIS FED. AID PROJECT				

FILE NAME = \\Quigg\Projects\Projects\2012\JOBS\12-92-09\PTB 164 11 02 1-74 Bridge Repairs-Traffic Control Plans\CADD\CADD Sheets\0810142-0143-64H83-010-exp.dwg  
 MODEL = Default  
 PLOT DRIVER = 12-92-09\_PDF.plt

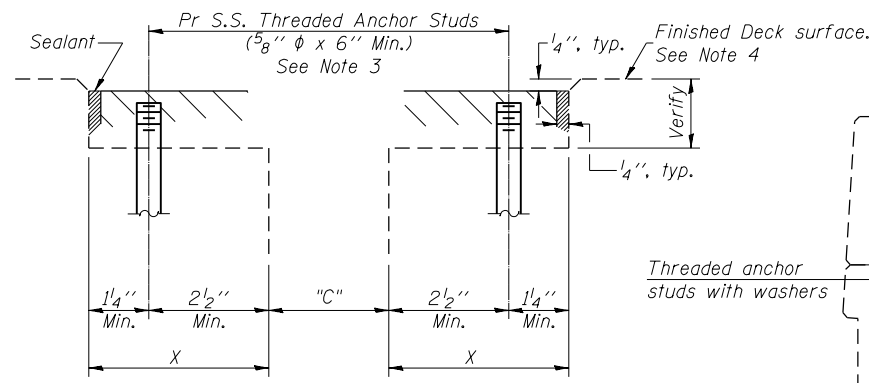
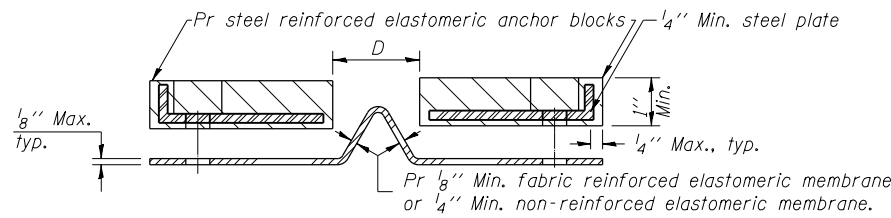

**CROSS SECTION - PROPOSED**  
Neoprene Exp. Jt.

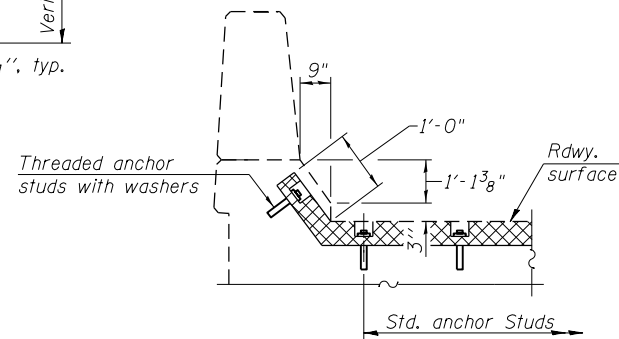

**AT PARAPET**

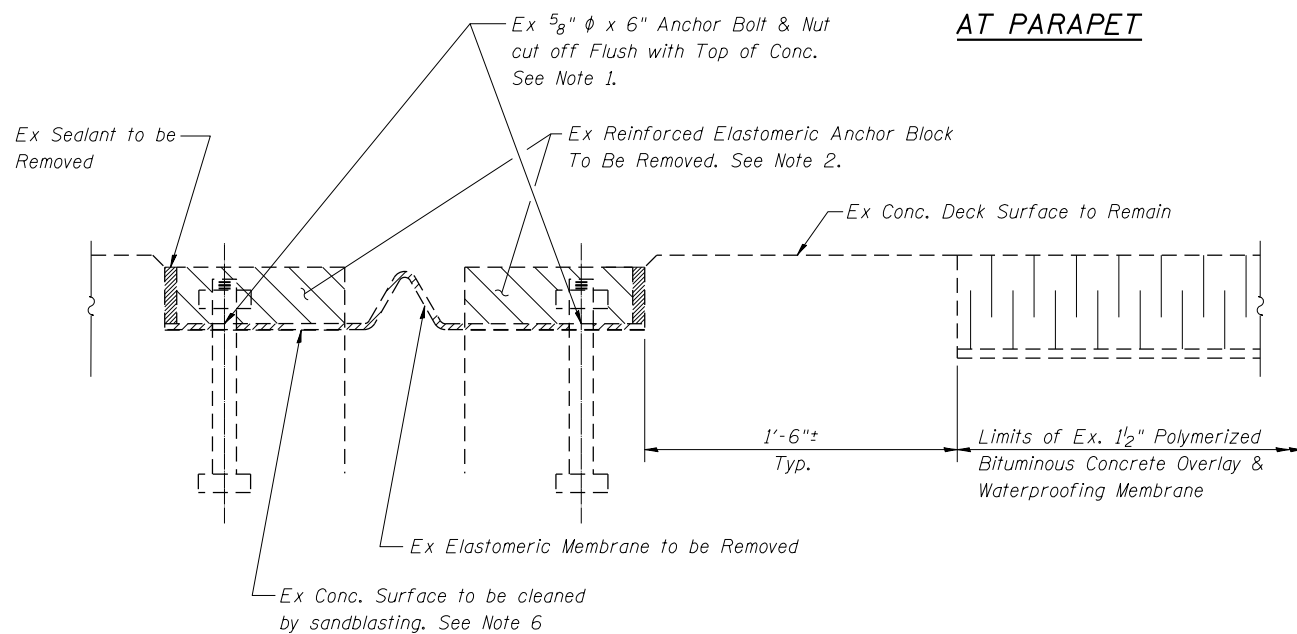

**CROSS SECTION - EXISTING**  
Neoprene Exp. Jt.

**NEOPRENE JOINT DETAILS**  
Designated as "A"

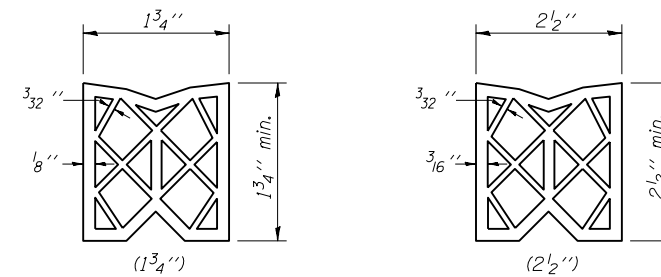

**PREFORMED JOINT SEAL**  
Designated as "B"

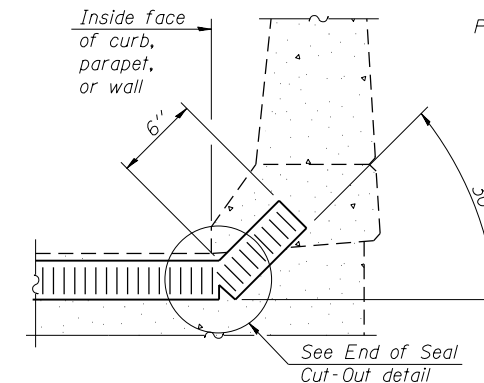

**AT CURB, PARAPET, OR WALL**  
(Showing seal)

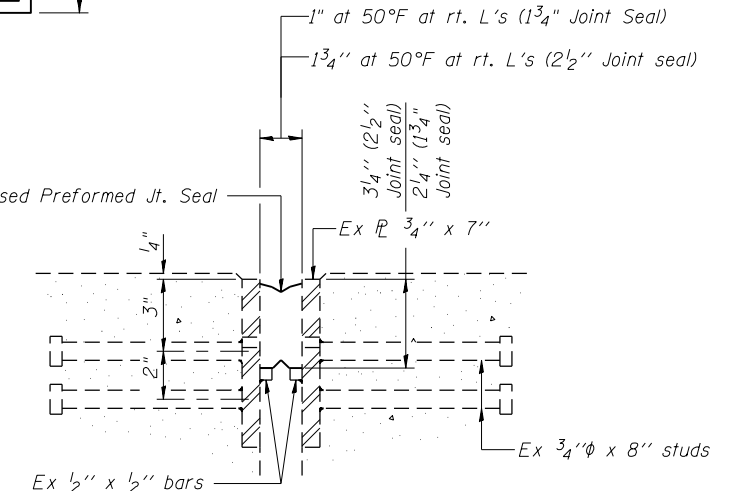

**CROSS SECTION-PROPOSED**  
Preformed Joint

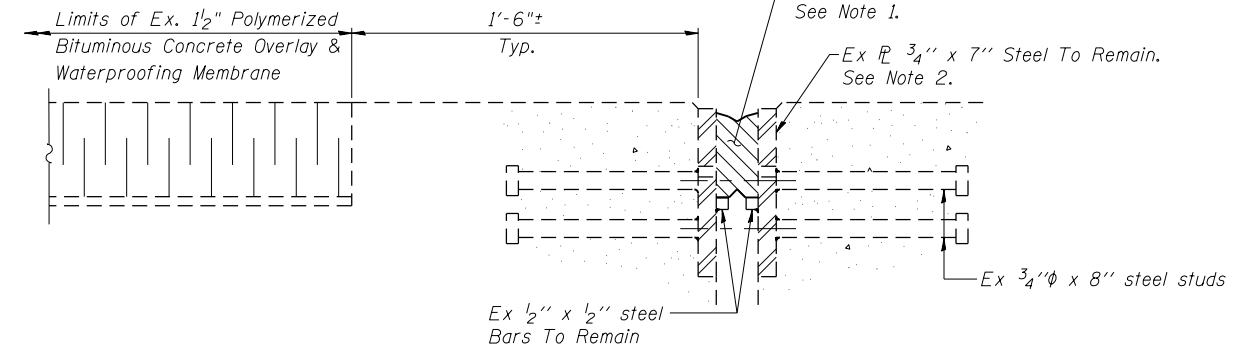

**CROSS SECTION - EXISTING**  
Preformed Joint Seal

**PREFORMED JOINT DETAILS**  
Designated as "B"

**Notes (Neoprene Expansion Joints):**

- All existing steel anchor Bolts shall be cut off flush or below concrete surface. Any projection shall be ground off flush.
- Existing anchor Blocks and Membrane shall be removed and disposed of properly.
- New 5/8 inch phi x 6 inch Stainless Steel Threaded Anchor Studs shall be drilled and Epoxy grouted in accordance with Art. 584 of the Standard Specifications at locations to fit New Neoprene Anchor Blocks. Layout of studs shall result in 6 inch minimum spacing from any existing anchor bolt.
- Contractor shall verify depth of existing Joint block-out prior to ordering material. Top of Joint Anchor block shall be 1/4 inch Below Existing deck surface.
- Cost included with NEOPRENE EXPANSION JOINT.
- Existing Concrete surfaces shall be cleaned to bare concrete by sandblasting. Depressions, bug holes, or other imperfections shall be repaired using POLYMER MODIFIED PORTLAND CEMENT MORTAR.

**Notes (Preformed Joint Seals):**

- Remove and Dispose of Existing rubber Joint seal.
- Clean Surface of steel plates above 1/2 inch bars by sandblasting to gray metal. Sandblasted areas shall be painted with one coat of Inorganic Zinc Rich Primer. Color shall be gray, Munsell No. 5B7/1.
- Cost included with PREFORMED JOINT SEAL.

USER NAME =	DESIGNED - MJK	REVISED
	CHECKED - DRB	REVISED
PLOT SCALE =	DRAWN - TRF	REVISED
PLOT DATE =	CHECKED - SCD	REVISED

F.A.I. RTE.	SECTION	COUNTY	TOTAL SHEETS	SHEET NO.
74	(81-IHVB & 81-IHVB-1)M-3	ROCK ISLAND	69	59
				CONTRACT NO. 64H83
ILLINOIS FED. AID PROJECT				

FILE NAME = \\Quigg\Projects\Projects\2012\JOBS\12-92-09\PTB 164 11 02 1-74 Bridge Repairs-Traffic Control Plans\CADD\Sheet\0810112-0143-64H83-011-steel-repair-01.dgn  
 MODEL = Default  
 PLOT DRIVER = 12-92-09\_PDF.plt

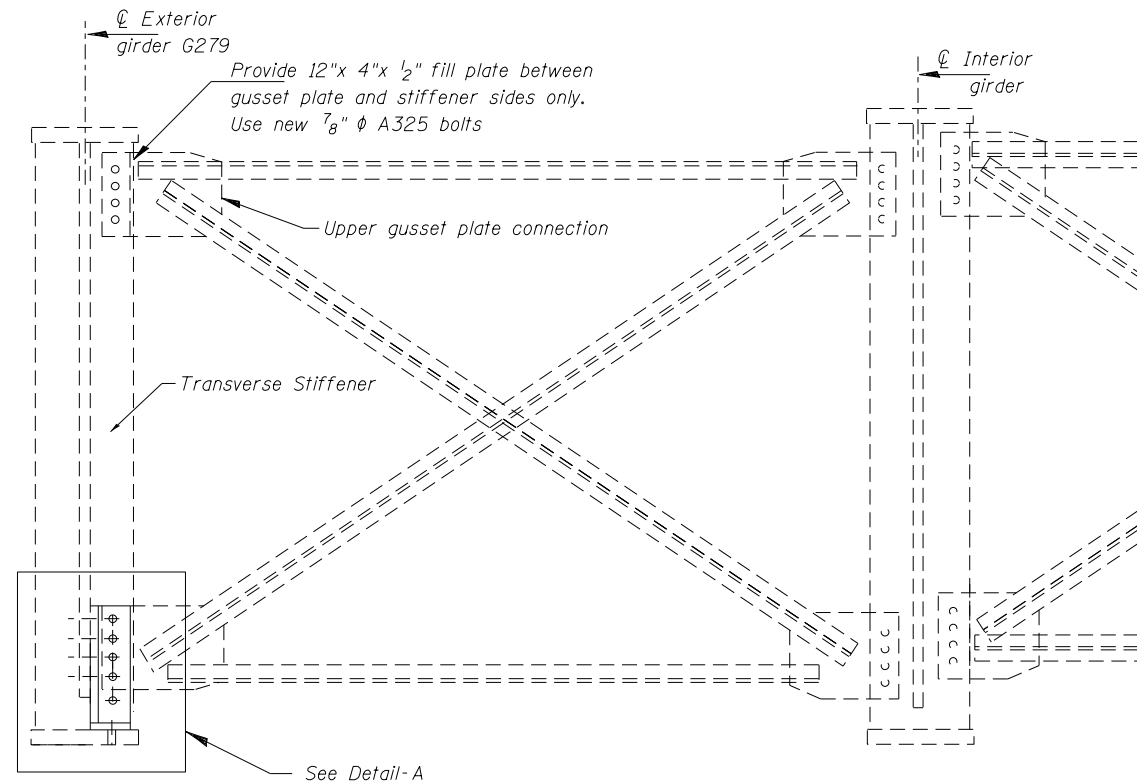

**INTERMEDIATE CROSS-FRAME DETAIL**

**Procedure for Detail A Repair**

Unbolt and remove existing strengthening angle on one side of the connection. Remove bolts at upper gusset plate connection and install 1/2" fill plate and new 7/8" diameter bolts

Drill 15/16" diameter holes thru existing web and stiffener holes and drill new holes thru girder flange to install the stiffening boxes on both sides of the existing stiffener.

Clean exposed steel surfaces to remove any contaminants or rusting.

Obtain approval of Engineer before proceeding. All ground and drilled surfaces shall be checked for cracks by magnetic particle testing.

Remove existing 7/8" diameter bolts from transverse stiffener.

Replace four fasteners to transverse stiffener with new 7/8" diameter A325 bolts.

Install new 7/8" diameter bolts in girder web & girder flange as shown.

Paint surfaces with undercoating prior to assembling connection. After connection is assembled paint with final coat as per Special Provision "Cleaning and Painting Existing Steel Structures".

Cost of this work shall be included in STRUCTURAL STEEL REPAIR.

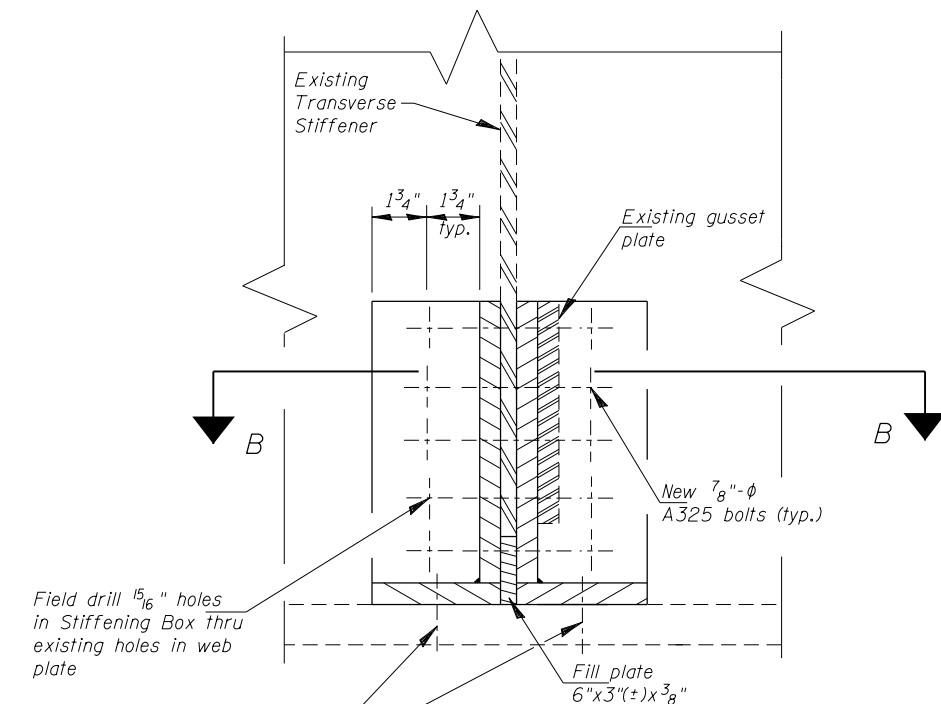

**DETAIL - A**

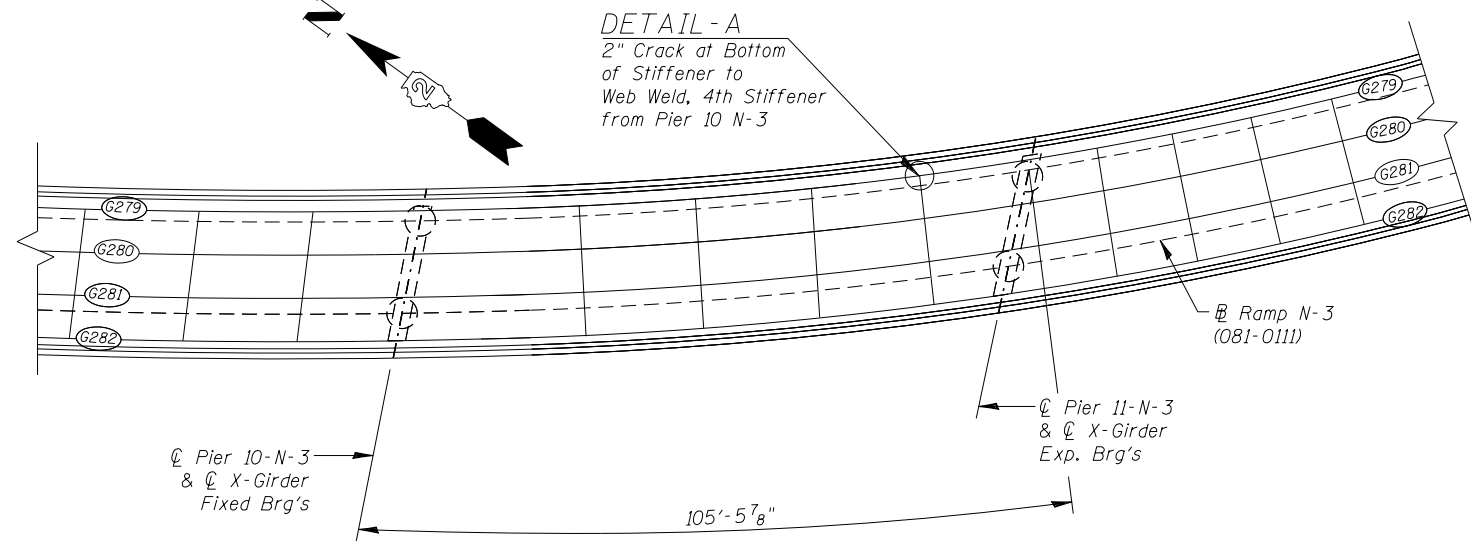

**PARTIAL PLAN**  
Ramp 081-0111

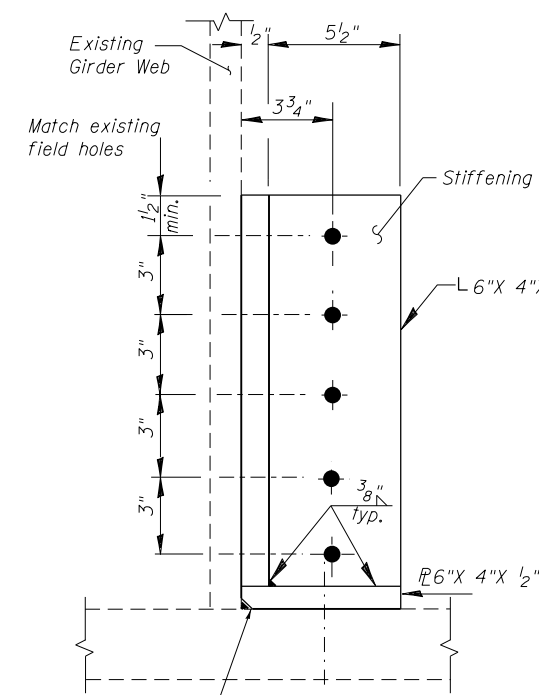

**SECTION C-C**

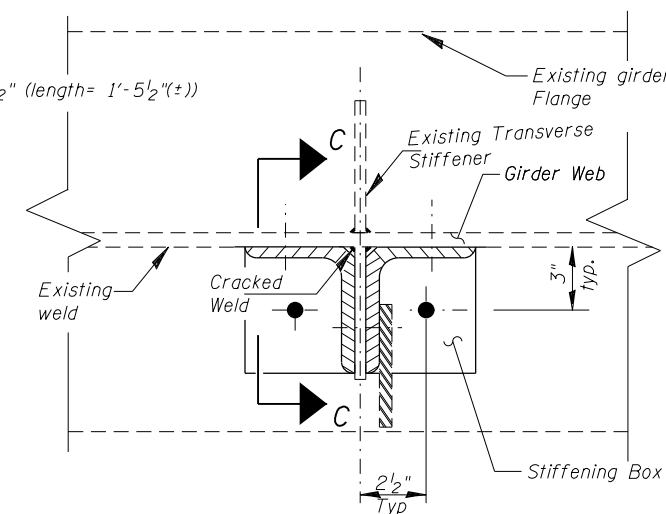

**SECTION B-B**



USER NAME =	DESIGNED - MJK	REVISED
	CHECKED - DRB	REVISED
PLOT SCALE =	DRAWN - TRF	REVISED
PLOT DATE =	CHECKED - SCD	REVISED

**STATE OF ILLINOIS  
DEPARTMENT OF TRANSPORTATION**

**CRACK REPAIR GIRDER 279 DETAIL-A  
STRUCTURE NO. 081-0111**

SHEET NO. 11 OF 20 SHEETS

F.A.I. RTE.	SECTION	COUNTY	TOTAL SHEETS	SHEET NO.
74	(81-IHVB & 81-IHVB-1)M-3	ROCK ISLAND	69	60
CONTRACT NO. 64H83				

ILLINOIS FED. AID PROJECT

**Procedure for Detail B Repair**

The provided  $1\frac{5}{16}$ "  $\phi$  stress relief hole is adequate to arrest the existing crack.

Clean exposed steel surfaces to remove any contaminants or rusting.

Paint surfaces with undercoating and final coat as per Special Provision "Cleaning and Painting Existing Steel Structures".

Obtain approval of Engineer before proceeding. All ground and drilled surfaces shall be checked for cracks by magnetic particle testing.

Cost of this work shall be included in STRUCTURAL STEEL REPAIR.

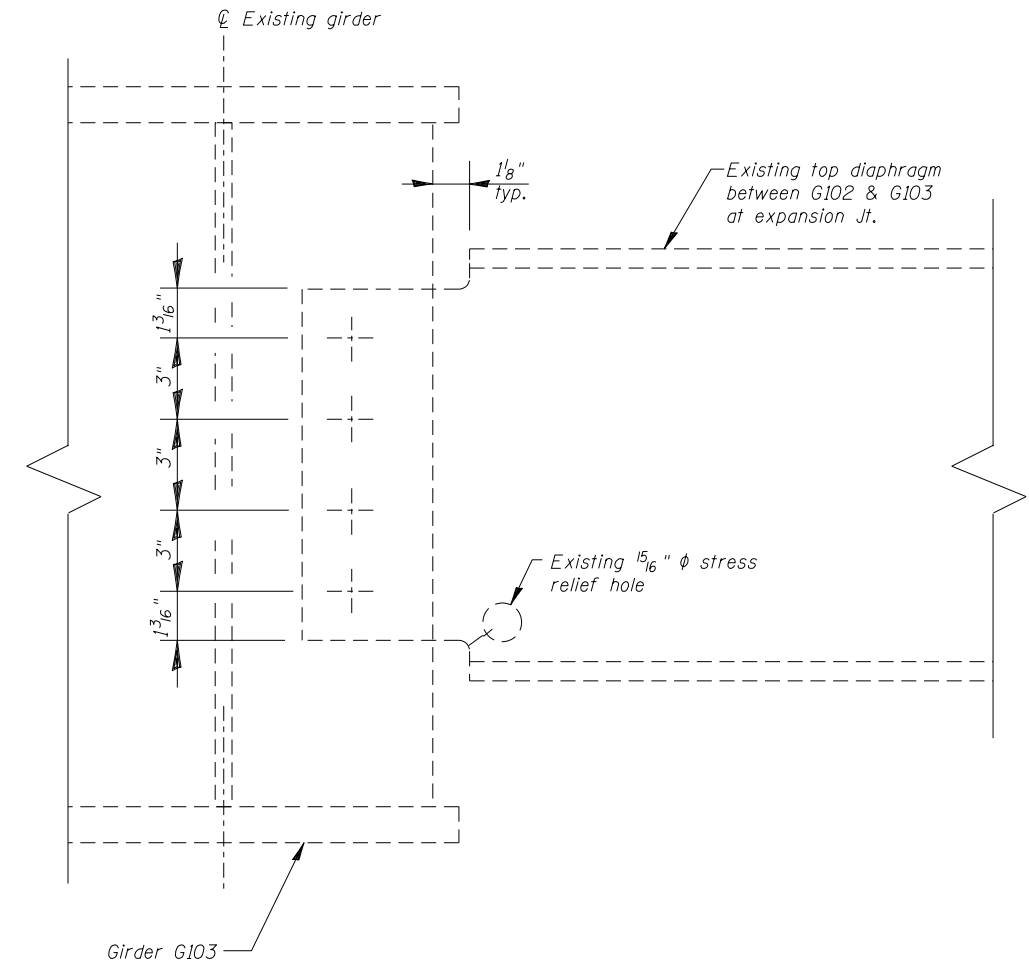

**DETAIL-B**

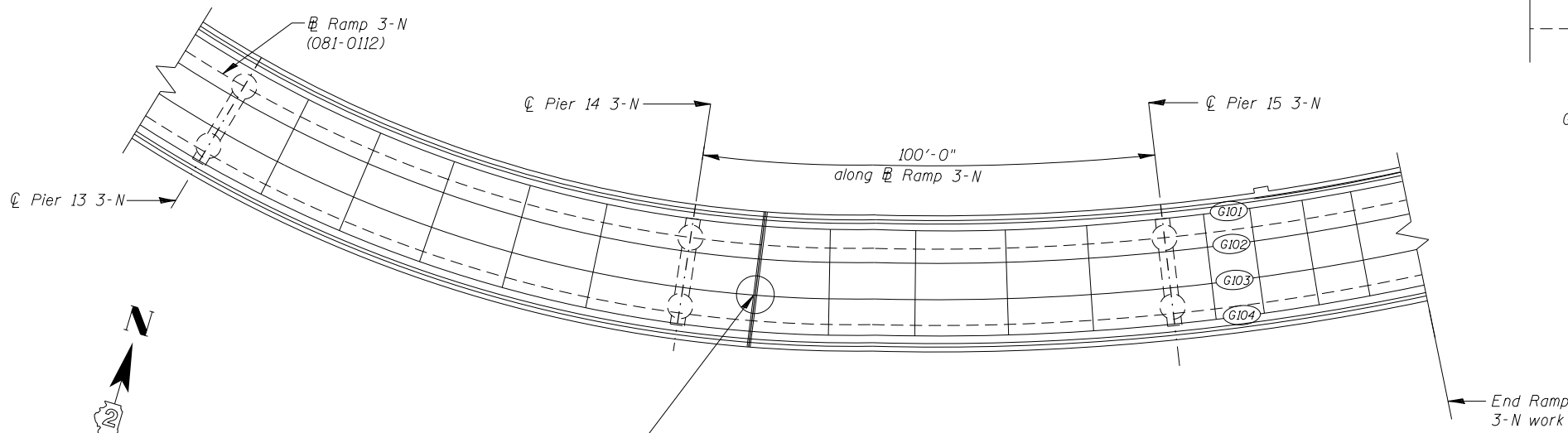

**Detail-B**  
Crack at corner of bottom cope on top diaphragm at G103 & Exp. Jt.

**PARTIAL PLAN**

(081-0112)



FILE NAME = \\Quigg\Projects\Projects\2012\JOBS\12-92-09\PTB 164 11 02 1-74 Bridge Repairs-Traffic Control Plans\CADD\Sheets\0810112-0143-64H83-012-steel-repair02.dgn  
MODEL = Default  
PLOT DRIVER = 12-92-09\_PDF.plt



USER NAME =	DESIGNED - MJK	REVISED
	CHECKED - DRB	REVISED
PLOT SCALE =	DRAWN - TRF	REVISED
PLOT DATE =	CHECKED - SCD	REVISED

**STATE OF ILLINOIS  
DEPARTMENT OF TRANSPORTATION**

**CRACK REPAIR GIRDER 103 DETAIL-B  
STRUCTURE NO. 081-0112**

SHEET NO. 12 OF 20 SHEETS

F.A.I. RTE.	SECTION	COUNTY	TOTAL SHEETS	SHEET NO.
74	181-1HVB & 81-1HVB-1JM-3	ROCK ISLAND	69	61
CONTRACT NO. 64H83				

ILLINOIS FED. AID PROJECT

**Procedure for Detail C Repair**

Drill two 1 1/2"  $\phi$  hole tangent to crossbeam as shown in Detail C.

Remove material in shaded area. Grind edges to provide smooth transitions between material removed and existing stress-relief hole.

Remove all burrs from cut edge and grind surface to obtain a surface roughness ( $R_a$ ) of 1000 or less.

Obtain approval of Engineer before proceeding. All ground and cored surfaces shall be checked for cracks by magnetic particle or dye penetrant testing.

Clean exposed steel surfaces to remove any contaminants or rusting.

Paint surfaces with undercoating and final coat as per Special Provision "Cleaning and Painting Existing Steel Structures".

Cost of this work shall be included in STRUCTURAL STEEL REPAIR.

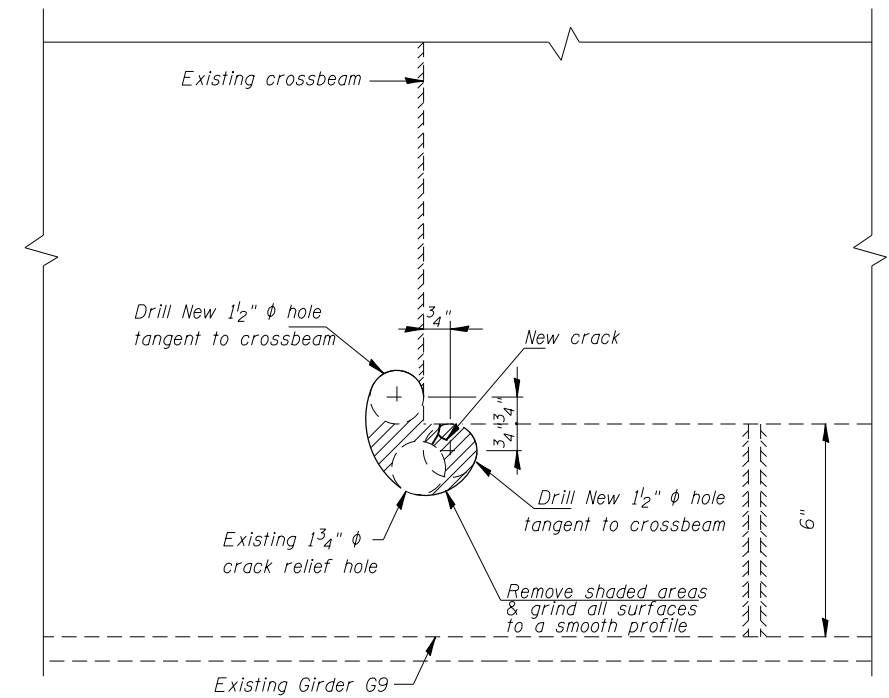

**DETAIL - C**

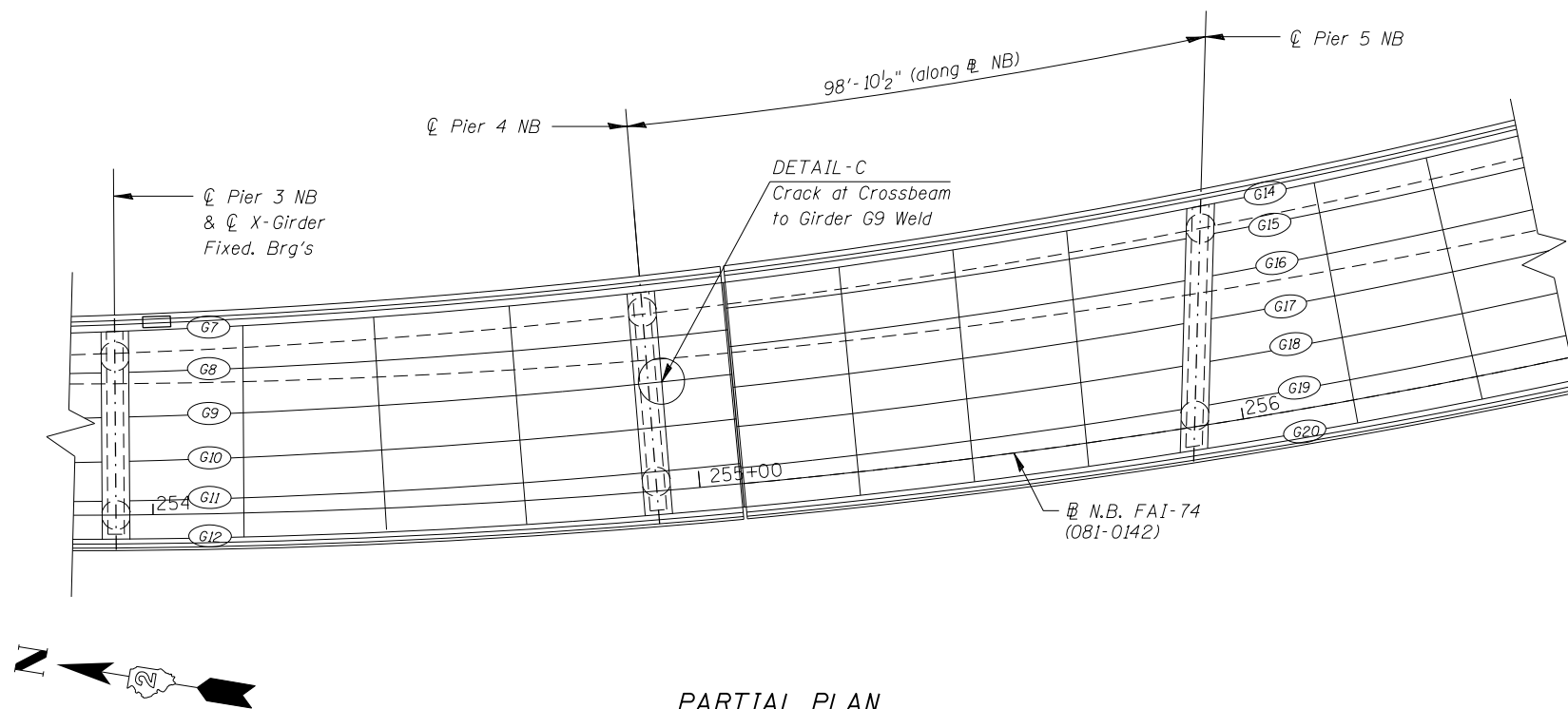

**PARTIAL PLAN**

SN 081-0142  
NB I-74

**STATE OF ILLINOIS  
DEPARTMENT OF TRANSPORTATION**

**CRACK REPAIR GIRDER 9 DETAIL-C  
STRUCTURE NO. 081-0142**

F.A.I. RTE.	SECTION	COUNTY	TOTAL SHEETS	SHEET NO.
74	(81-IHVB & 81-IHVB-1)M-3	ROCK ISLAND	69	62
CONTRACT NO. 64H83				

SHEET NO. 13 OF 20 SHEETS

ILLINOIS FED. AID PROJECT

FILE NAME = \\Quigg\Projects\Projects\2012\JOBS\12-92-09\PTB 164 11 02 1-74 Bridge Repairs-Traffic Control Plans\CADD\Sheets\0810142-0143-64H83-013-steel-repair-03.dgn  
MODEL = Default  
PLOT DRIVER = 12-92-091.PDF.plt



USER NAME =	DESIGNED - MJK	REVISED
	CHECKED - DRB	REVISED
PLOT SCALE =	DRAWN - TRF	REVISED
PLOT DATE =	CHECKED - SCD	REVISED

**Procedure for Detail D Repair**

Remove nuts only from the 6 upper connection bolts in stiffener, leaving bolts in place, and place a 1/2" plate shown with holes matching the connection bolts locations. Replace the 6 bolts one at a time and snug tight the nut until all 6 bolts are in place all snug tight.

Using Mending Plate as a template, Field drill holes in existing transfer beam and install bolts.

Tighten all new bolts in place.

Obtain approval of Engineer before proceeding. All ground and drilled surfaces shall be checked for cracks by magnetic particle testing.

Clean exposed steel surfaces to remove any contaminants or rusting.

Paint surfaces with undercoating prior to assembling connection. After connection is assembled paint with final coat as per Special Provision "Cleaning and Painting Existing Steel Structures".

Cost of this work shall be included in STRUCTURAL STEEL REPAIR.

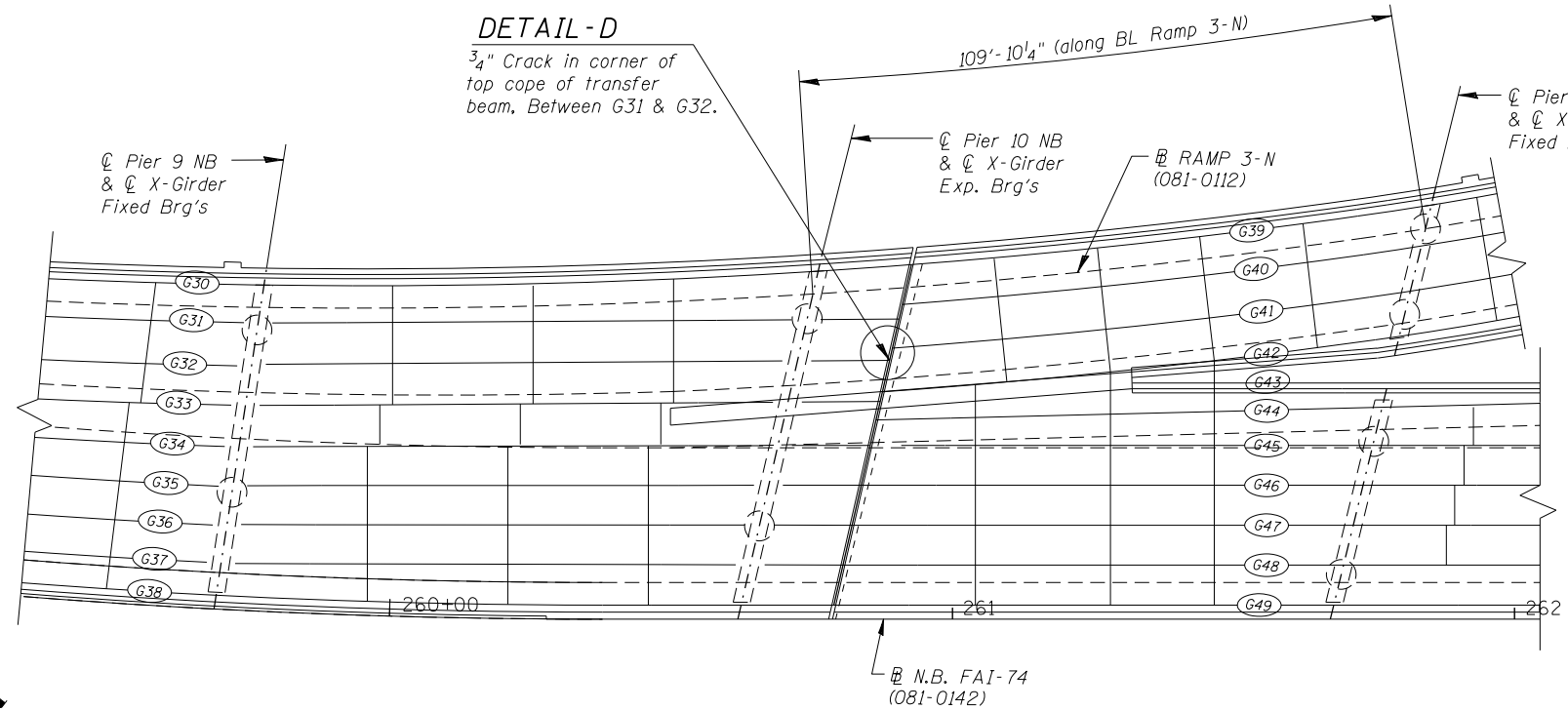
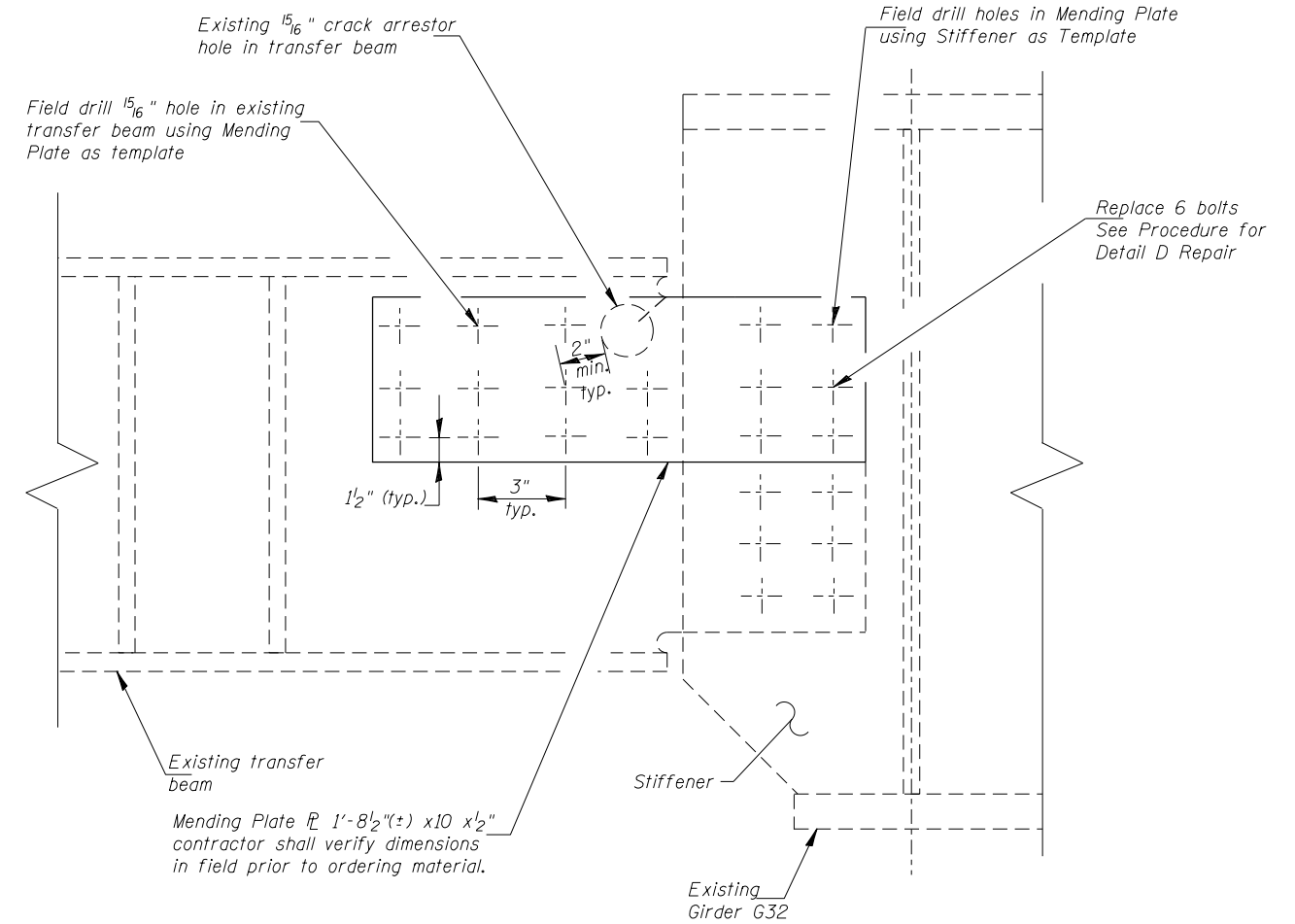

**PARTIAL PLAN**  
NB I-74 & RAMP 3-N  
081-0142 & 081-0112

**DETAIL-D**  
Crack at upper corner of transfer beam to Girder G32

FILE NAME = \\Quigg\Projects\Projects\2012\JOBS\12-92-09\PTB 164 11 02 1-74 Bridge Repairs-Traffic Control Plans\CADD Sheets\0810142-0143-64H83-014-steel-repair04.dgn  
MODEL = Default  
PLOT DRIVER = 12-92-09\_PDF.plt



USER NAME =	DESIGNED - MJK	REVISED
	CHECKED - DRB	REVISED
PLOT SCALE =	DRAWN - TRF	REVISED
PLOT DATE =	CHECKED - SCD	REVISED

**STATE OF ILLINOIS**  
**DEPARTMENT OF TRANSPORTATION**

**CRACK REPAIR BTWN G31 & G32 DETAIL-D**  
**STRUCTURE NO. 081-0142**

SHEET NO. 14 OF 20 SHEETS

F.A.I. RTE.	SECTION	COUNTY	TOTAL SHEETS	SHEET NO.
74	(81-1HVB & 81-1HVB-1)M-3	ROCK ISLAND	69	63
CONTRACT NO. 64H83				
ILLINOIS FED. AID PROJECT				

**Procedure for Detail E Repair**

Drill two 1/2"  $\phi$  holes through the girder web as shown in Detail E.

Remove material in shaded area. Grind edges to provide smooth transitions between material removed and existing stress-relief hole.

The transition partial circle is tangent to both 1/2"  $\phi$  holes as shown.

Remove all burrs from cut edge and grind surface to obtain a surface roughness ( $R_a$ ) of 1000 or less. Grinding operation shall use 1/2 in. diameter or larger carbide burrs.

Obtain approval of Engineer before proceeding. All ground and drilled surfaces shall be checked for cracks by magnetic particle or dye penetrant testing.

Clean exposed steel surfaces to remove any contaminants or rusting.

Paint surfaces with undercoating and final coat as per Special Provision "Cleaning and Painting Existing Steel Structures".

Cost of this work shall be included in STRUCTURAL STEEL REPAIR.

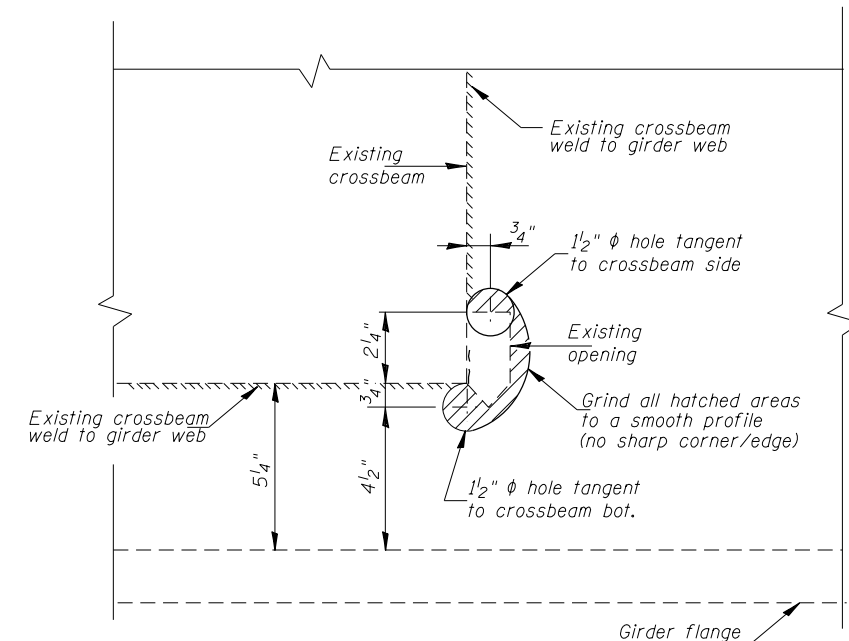

**DETAIL-E**  
Crack along crossbeam side weld to G223

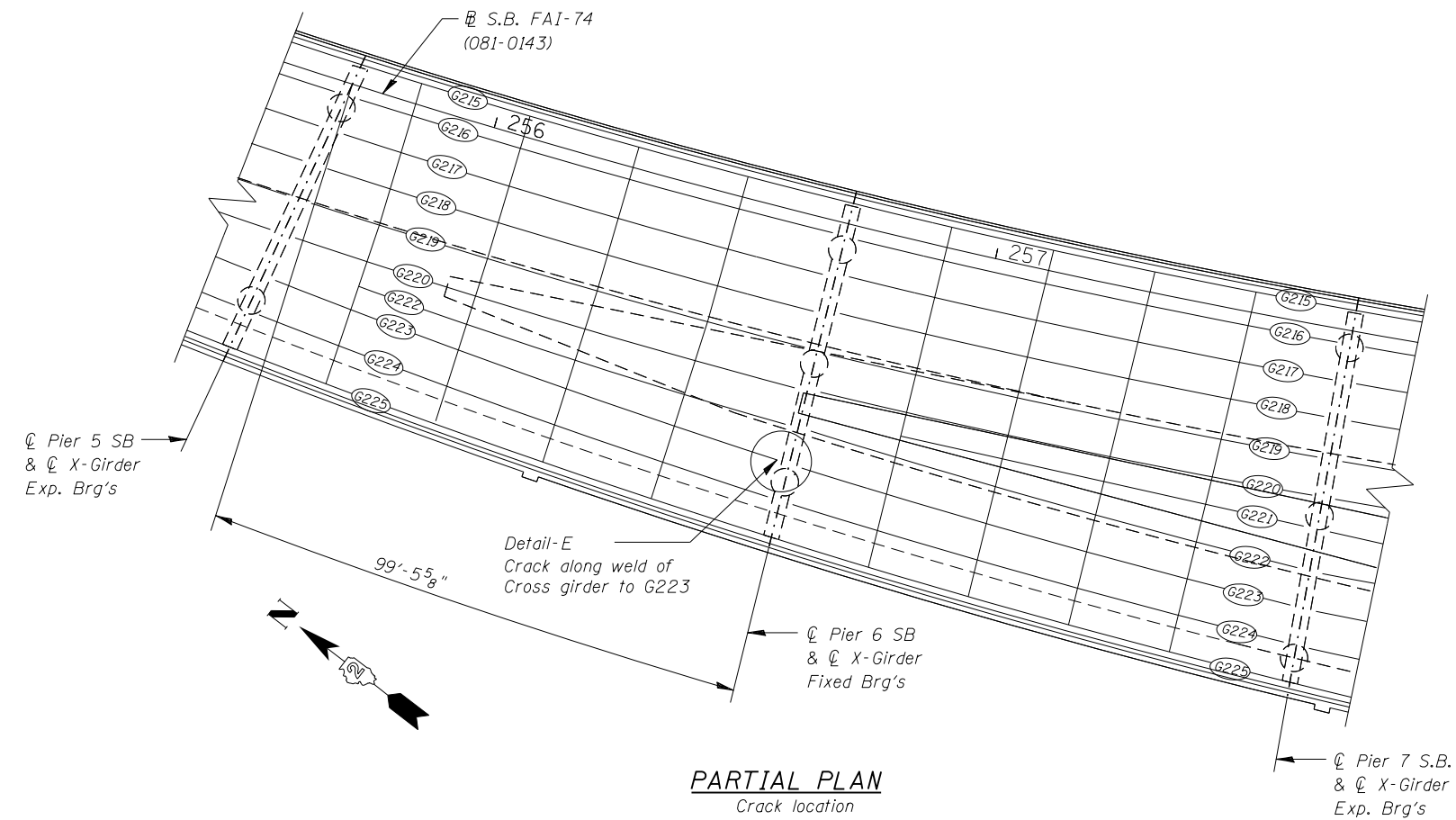

**PARTIAL PLAN**  
Crack location

FILE NAME = \\Quigg\Projects\Projects\2012\JOBS\12-92-09\PTB 164 11 02 1-74 Bridge Repairs-Traffic Control Plans\CADD Sheets\0810142-0143-64H83-015-steel-repair-05.dgn  
MODEL = Default  
PLOT DRIVER = 12-92-09\_PDF.plt



USER NAME =	DESIGNED - MJK	REVISED
	CHECKED - DRB	REVISED
PLOT SCALE =	DRAWN - TRF	REVISED
PLOT DATE =	CHECKED - SCD	REVISED

**STATE OF ILLINOIS  
DEPARTMENT OF TRANSPORTATION**

**CRACK REPAIR GIRDER 223 DETAIL-E  
STRUCTURE NO. 081-0143**

SHEET NO. 15 OF 20 SHEETS

F.A.I. RTE.	SECTION	COUNTY	TOTAL SHEETS	SHEET NO.
74	(81-IHVB & 81-IHVB-1)M-3	ROCK ISLAND	69	64
CONTRACT NO. 64H83				
ILLINOIS FED. AID PROJECT				



**Procedure for Detail F Repair**

The provided  $\frac{15}{16}$ "  $\phi$  crack relief hole is adequate to arrest the developed crack.

Clean exposed steel surfaces to remove any contaminants or rusting.

Obtain approval of Engineer before proceeding. All ground and drilled surfaces shall be checked for cracks by magnetic particle testing.

Paint surfaces with undercoating prior to assembling connection. After connection is assembled paint with final coat as per Special Provision "Cleaning and Painting Existing Steel Structures".

Cost of this work shall be included in STRUCTURAL STEEL REPAIR.

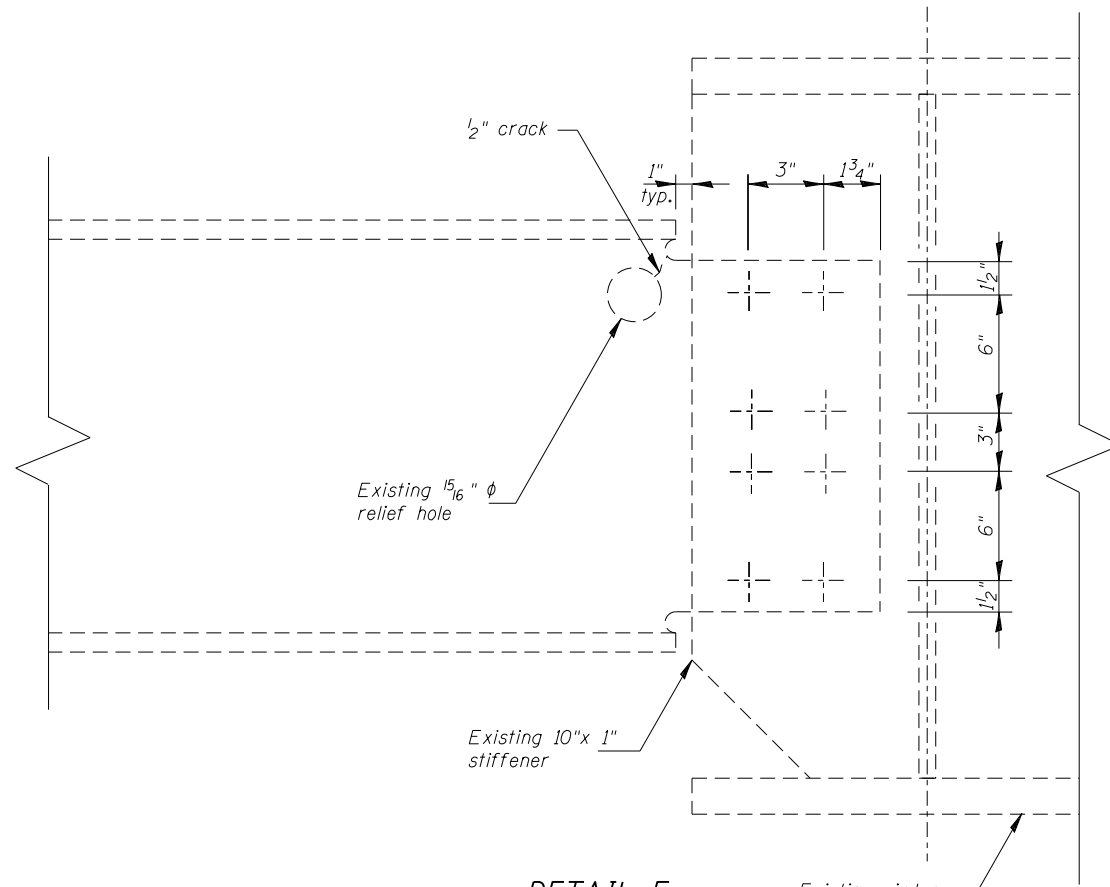

**DETAIL - F**

Crack at top cope on bottom diaphragm at girder G242

**DETAIL - F**

1/2" Crack @ corner of top cope on bottom diaphragm @ G242

S.B. FAI-74 (081-0143)

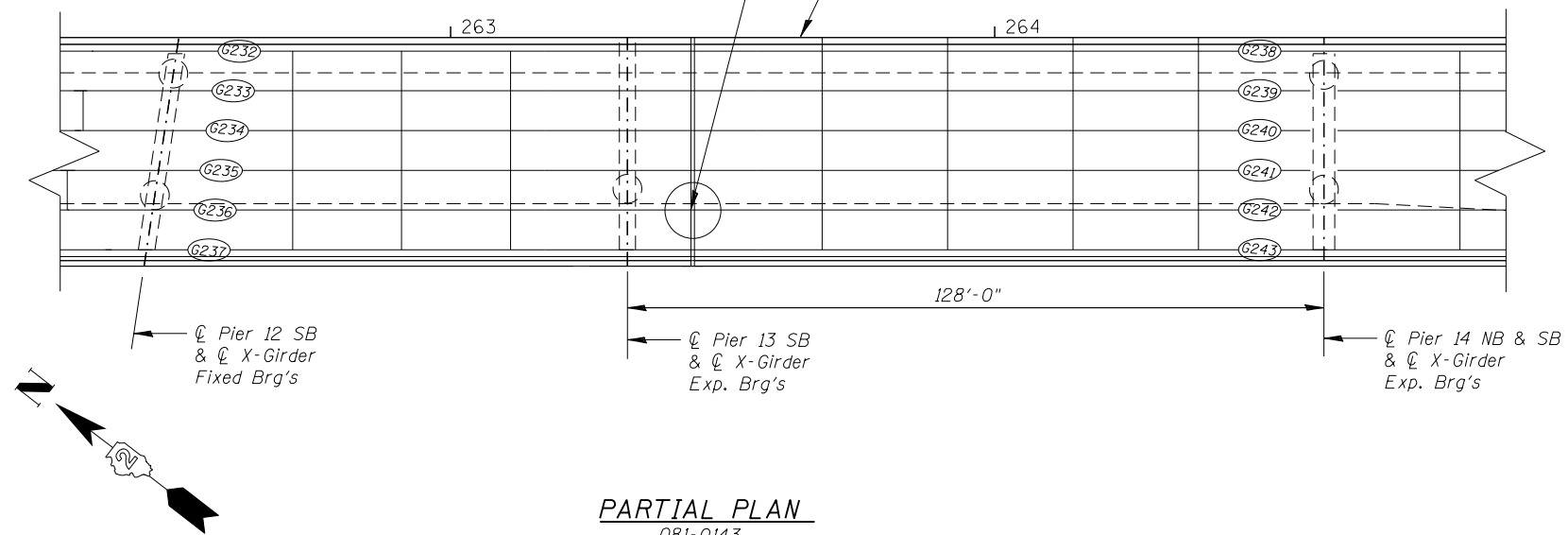

**PARTIAL PLAN**  
081-0143

FILE NAME = \\Quigg\Projects\Projects\2012\JOBS\12-92-09\PTB 164 11 02 1-74 Bridge Repairs-Traffic Control Plans\CADD Sheets\0810142-0143-64H83-016-steel-repair-06.dgn  
MODEL = Default  
PLOT DRIVER = 12-92-09\_PDF.plt



USER NAME =	DESIGNED - MJK	REVISED
	CHECKED - DRB	REVISED
PLOT SCALE =	DRAWN - TRF	REVISED
PLOT DATE =	CHECKED - SCD	REVISED

**STATE OF ILLINOIS  
DEPARTMENT OF TRANSPORTATION**

**CRACK REPAIR GIRDER 242 DETAIL-F  
STRUCTURE NO. 081-0143**

SHEET NO. 16 OF 20 SHEETS

F.A.I. RTE.	SECTION	COUNTY	TOTAL SHEETS	SHEET NO.
74	181-1HVB & 81-1HVB-1JM-3	ROCK ISLAND	69	65
CONTRACT NO. 64H83				

ILLINOIS FED. AID PROJECT

**Procedure for Detail G & H Repair**

Drill partial 1 3/4" φ & 2" φ hole through the girder web plate as shown in Details G & H respectively as shown.

Remove material in shaded area by saw cutting. Grind edges to provide smooth transitions between material removed and existing stress-relief hole.

Remove all burrs from cut edge and grind surface to obtain a surface roughness (R<sub>a</sub>) of 1000 or less. Grinding operation shall use 1/2 in. diameter or larger carbide burrs.

Obtain approval of Engineer before proceeding. All ground and drilled surfaces shall be checked for cracks by magnetic particle or dye penetrant testing.

Clean exposed steel surfaces to remove any contaminants or rusting.

Paint surfaces with undercoating and final coat as per Special Provision "Cleaning and Painting Existing Steel Structures".

Cost of this work shall be included in STRUCTURAL STEEL REPAIR.

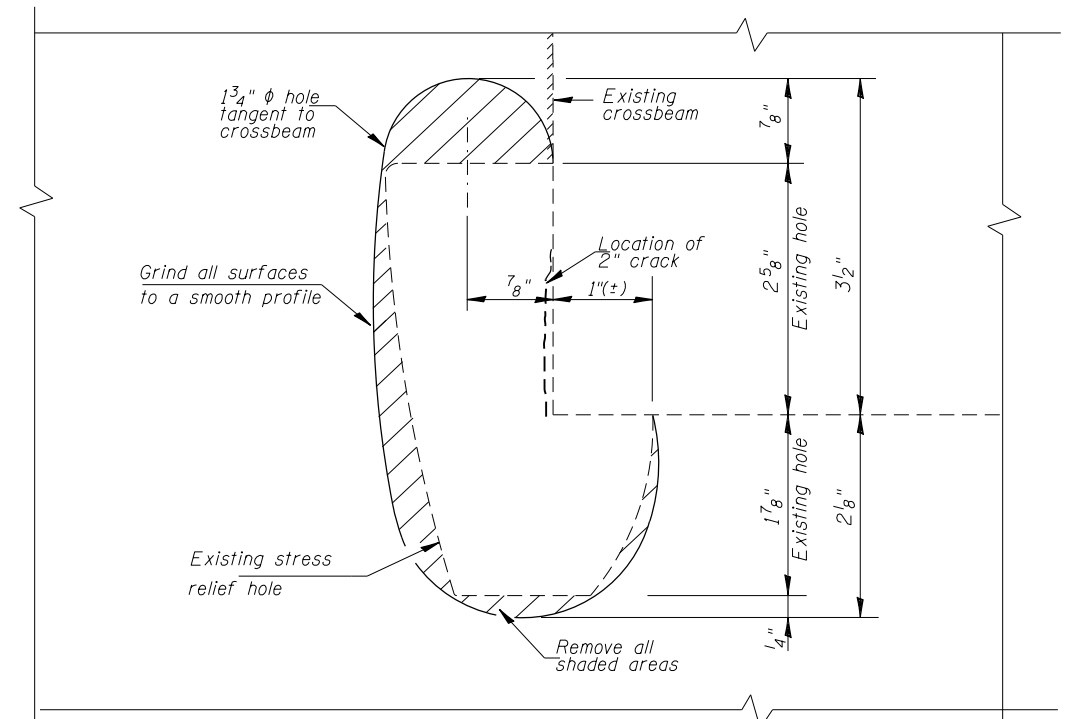

**DETAIL-G**

Crack in Crossbeam to girder G266 btwn spans 22 and 23

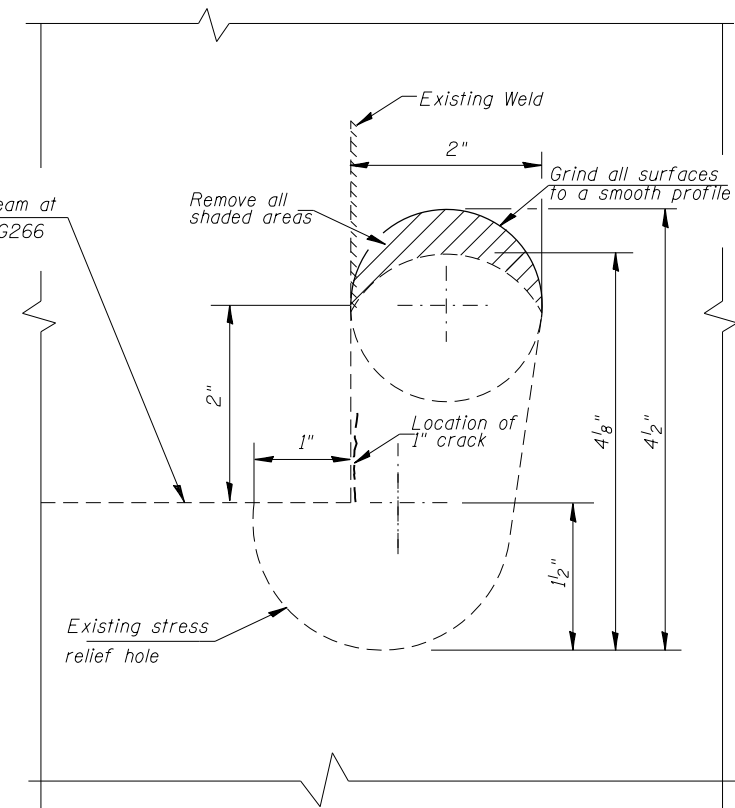

**DETAIL-H**

Crack in Crossbeam to girder G266 btwn spans 21 and 22

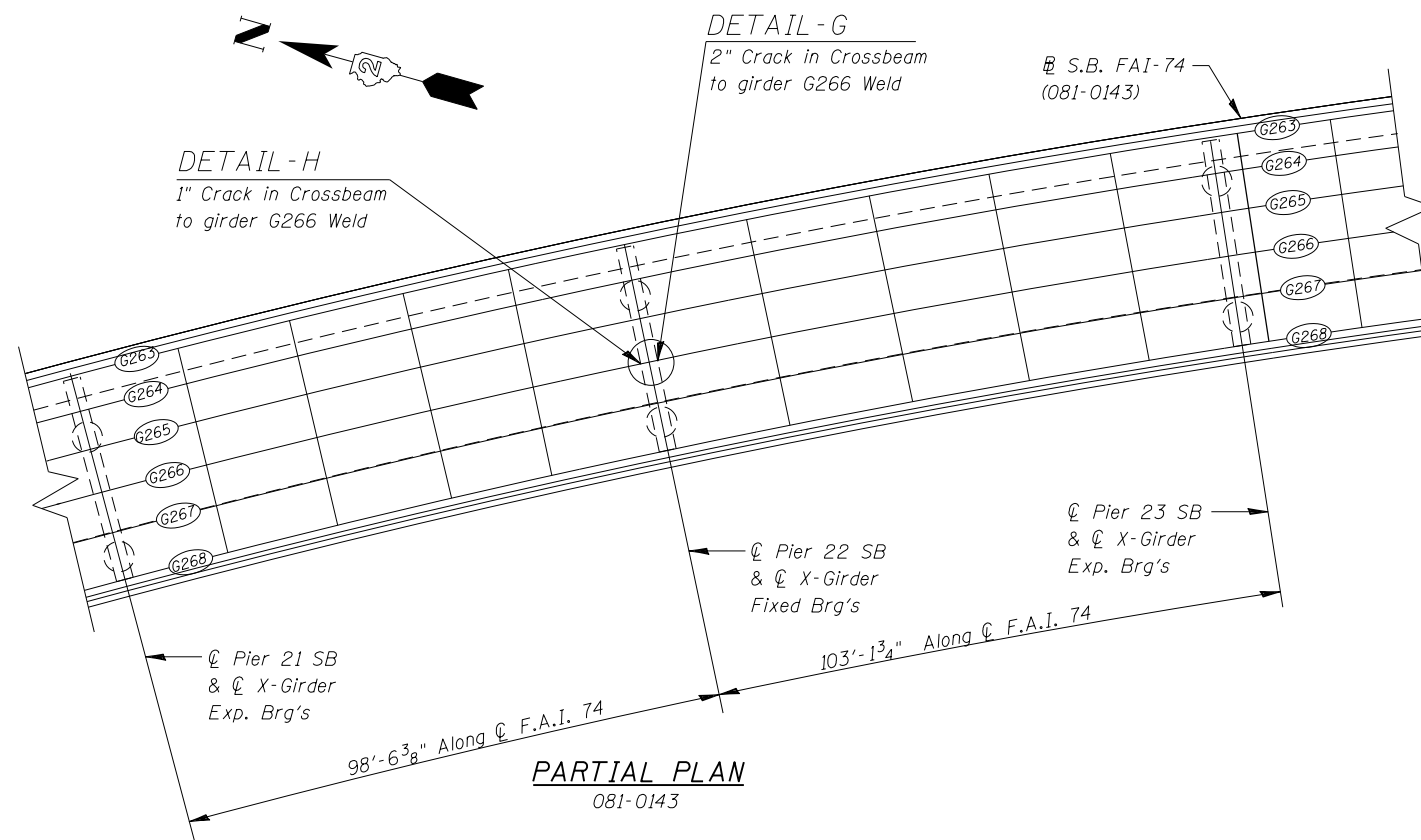

**PARTIAL PLAN**  
081-0143

FILE NAME = \\Quigg\Projects\Projects\2012\JOBS\12-92-09\PTB 164 11 02 1-74 Bridge Repairs-Traffic Control Plans\CADD\Sheet\0810142-0143-64H83-017-steel-repair07.dgn  
MODEL = Default  
PLOT DRIVER = 12-92-091.PDF.plt



USER NAME =	DESIGNED - MJK	REVISED
	CHECKED - DRB	REVISED
PLOT SCALE =	DRAWN - TRF	REVISED
PLOT DATE =	CHECKED - SCD	REVISED

**STATE OF ILLINOIS  
DEPARTMENT OF TRANSPORTATION**

**CRACK REPAIR GIRDER 266 DETAILS G & H  
STRUCTURE NO. 081-0143**

SHEET NO. 17 OF 20 SHEETS

F.A.I. RTE.	SECTION	COUNTY	TOTAL SHEETS	SHEET NO.
74	(81-IHVB & 81-IHVB-1)M-3	ROCK ISLAND	69	66
CONTRACT NO. 64H83				

ILLINOIS FED. AID PROJECT

When "A" is 3'-6" or less, the temporary concrete barrier shall be anchored to the new slab according to Detail I or Detail II. No anchorage is required when "A" is greater than 3'-6".

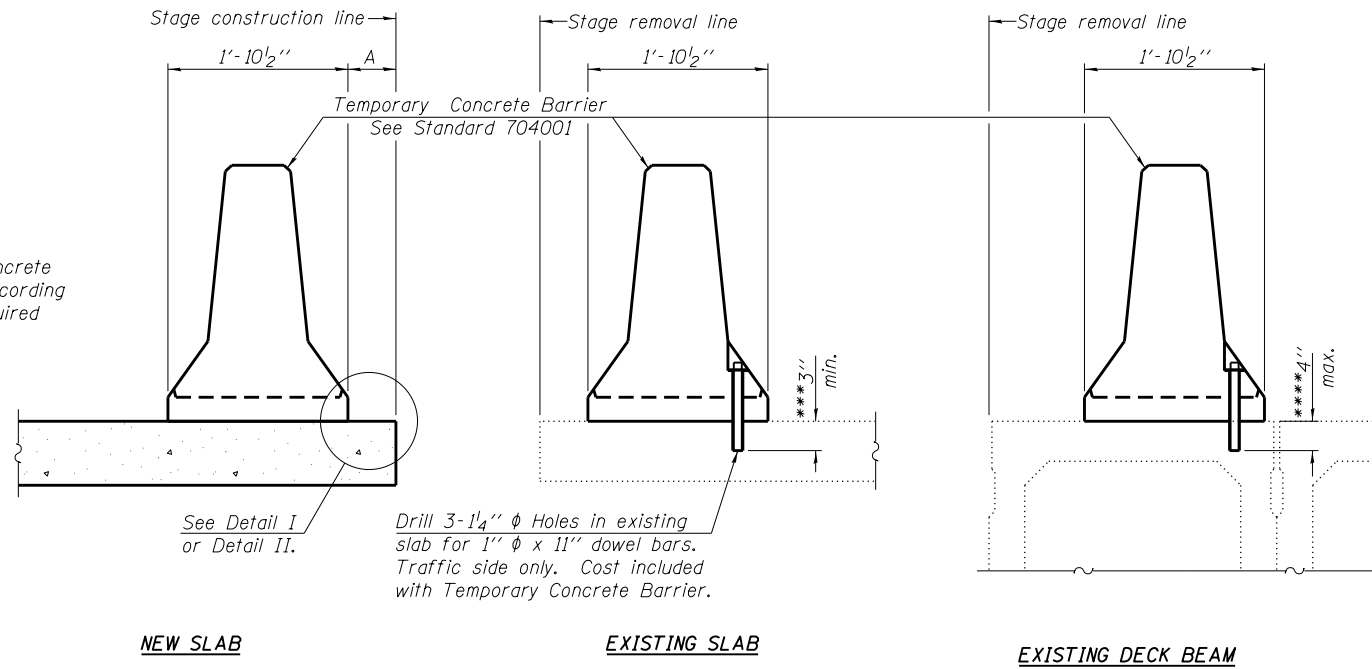

**SECTIONS THRU SLAB OR DECK BEAM**

**NOTES**

Detail I - With Bar Splicer or Couplers:  
Connect one (1) 1" x 7" x "W" steel PL to the top layer of couplers with 2-5/8" φ bolts screwed to coupler at approximate C of each barrier panel.

Detail II - With Extended Reinforcement Bars:  
Connect one (1) 1" x 7" x "W" steel PL to the concrete slab or concrete wearing surface with 2-5/8" φ Expansion Anchors or cast in place inserts spaced between the top layer of reinforcement at approximate C of each barrier panel.

Cost of anchorage is included with Temporary Concrete Barrier. The 1" x 7" x "W" plate shall not be removed until stage II construction forms and all reinforcement bars are in place and the concrete is ready to be placed.

\*\*\* Dimension shown is minimum required embedment into concrete. If hot-mix asphalt wearing surface is present, minimum embedment shall be in addition to wearing surface depth.

\*\*\*\* If existing deck beam is to remain in place after stage construction, embedment shall only be into wearing surface and not into existing deck beam concrete.

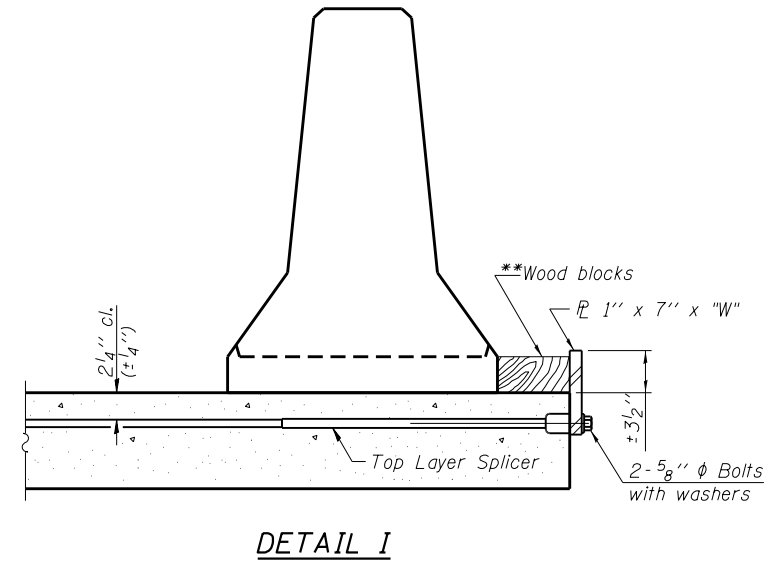

**DETAIL I**

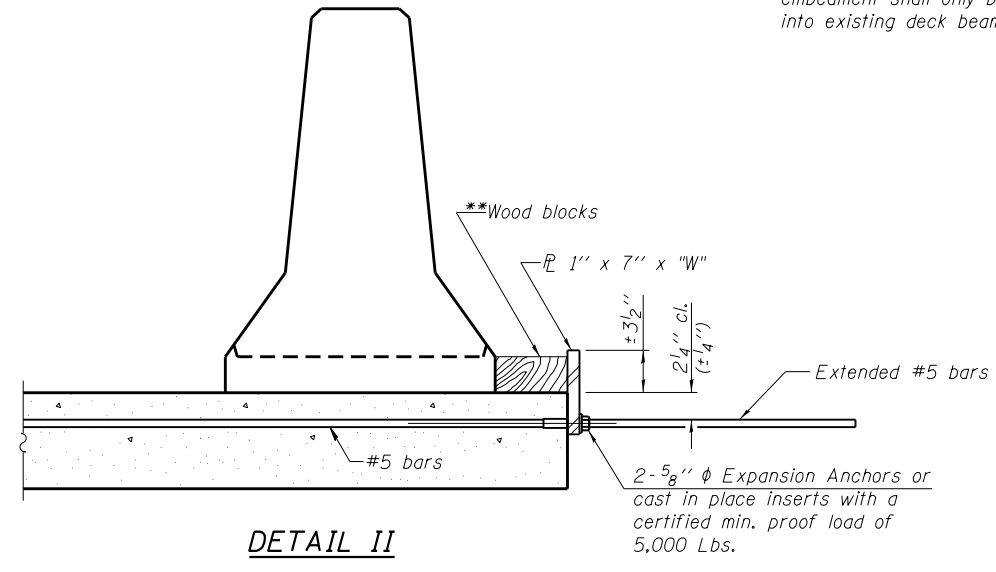

**DETAIL II**

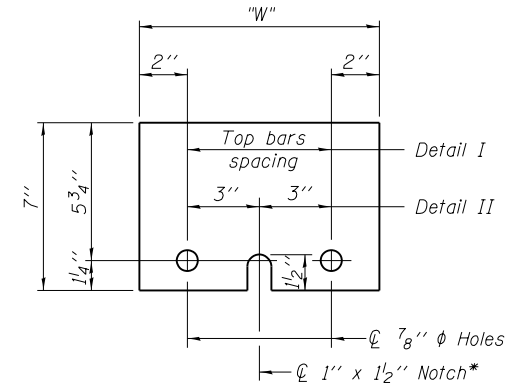

**STEEL RETAINER PL 1" x 7" x "W"**  
\* Required only with Detail II

\*\* Wood blocks may be omitted when required to provide minimum stage traffic lane width. When the wood blocks are omitted, the concrete barrier shall be in direct contact with the steel retainer plate.

"W" = Top bars spacing + 4"

FILE NAME = \\Quigg\Projects\Projects\2012\JOBS\12-92-09\PTB 164 11 02 1-74 Bridge Repairs-Traffic Control Plans\CADD\CADD Sheets\0810142-0143-64H83-018-TempConcBarr.dgn  
MODEL = Default  
PLOT DRIVER = 12-92-09\_PDF.plt

R-27 7-1-10



USER NAME =	DESIGNED - MJK	REVISED
	CHECKED - DRB	REVISED
PLOT SCALE =	DRAWN - TRF	REVISED
PLOT DATE =	CHECKED - SCD	REVISED

**STATE OF ILLINOIS  
DEPARTMENT OF TRANSPORTATION**

**TEMPORARY CONCRETE BARRIER FOR STAGE CONSTRUCTION  
STRUCTURE NO. 081-0142 & 081-0143**

SHEET NO. 18 OF 20 SHEETS

F.A.I. R.E.	SECTION	COUNTY	TOTAL SHEETS	SHEET NO.
74	(81-IHVB & 81-IHVB-1)M-3	ROCK ISLAND	69	67
			CONTRACT NO. 64H83	
ILLINOIS FED. AID PROJECT				

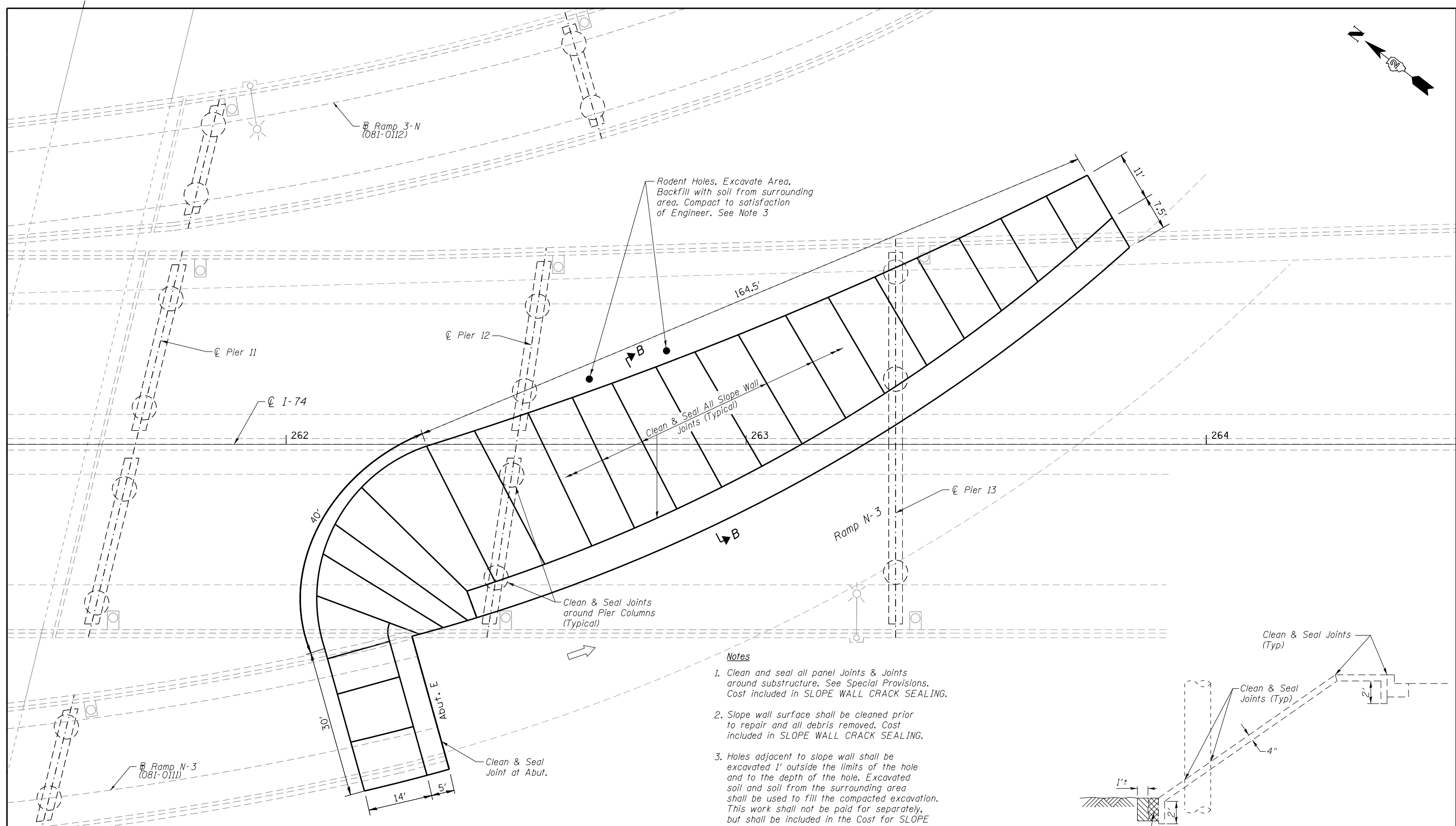
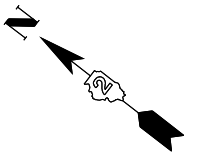

**PLAN**

**Notes**

1. Clean and seal all panel joints & joints around substructure. See Special Provisions. Cost included in SLOPE WALL CRACK SEALING.
2. Slope wall surface shall be cleaned prior to repair and all debris removed. Cost included in SLOPE WALL CRACK SEALING.
3. Holes adjacent to slope wall shall be excavated 1' outside the limits of the hole and to the depth of the hole. Excavated soil and soil from the surrounding area shall be used to fill the compacted excavation. This work shall not be paid for separately, but shall be included in the Cost for SLOPE WALL CRACK SEALING.

**BILL OF MATERIAL**

Item	Unit	Total
Slope Wall Crack Sealing	Foot	1031

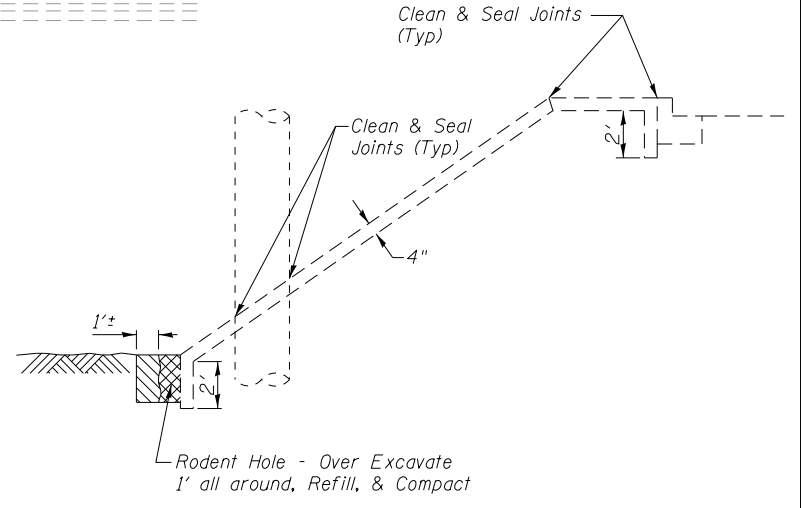

**SECTION B-B - SLOPE WALL - ABUT 'E'**

FILE NAME = \\Quigg\Projects\Projects\2012\JOBS\12-92-09\PTB 164 11 02 1-74 Bridge Repairs-Traffic Control Plans\CADD\CADD Sheets\081-0142-0143-64H83-019-SlopeWallRepair.dgn  
 MODEL = Default  
 PLOT DRIVER = 12-92-09\_PDF.plt



USER NAME =	DESIGNED - MJK	REVISED
	CHECKED - DRB	REVISED
PLOT SCALE =	DRAWN - TRF	REVISED
PLOT DATE =	CHECKED - SCD	REVISED

**STATE OF ILLINOIS  
DEPARTMENT OF TRANSPORTATION**

**SLOPE WALL REPAIR - ABUTMENT E  
STRUCTURE NO. 081-0142 & 081-0143 & 081-0111**

SHEET NO. 19 OF 20 SHEETS

F.A.I. RTE.	SECTION	COUNTY	TOTAL SHEETS	SHEET NO.
74	(81-IHVB & 81-IHVB-1)M-3	ROCK ISLAND	69	68
CONTRACT NO. 64H83				
ILLINOIS FED. AID PROJECT				

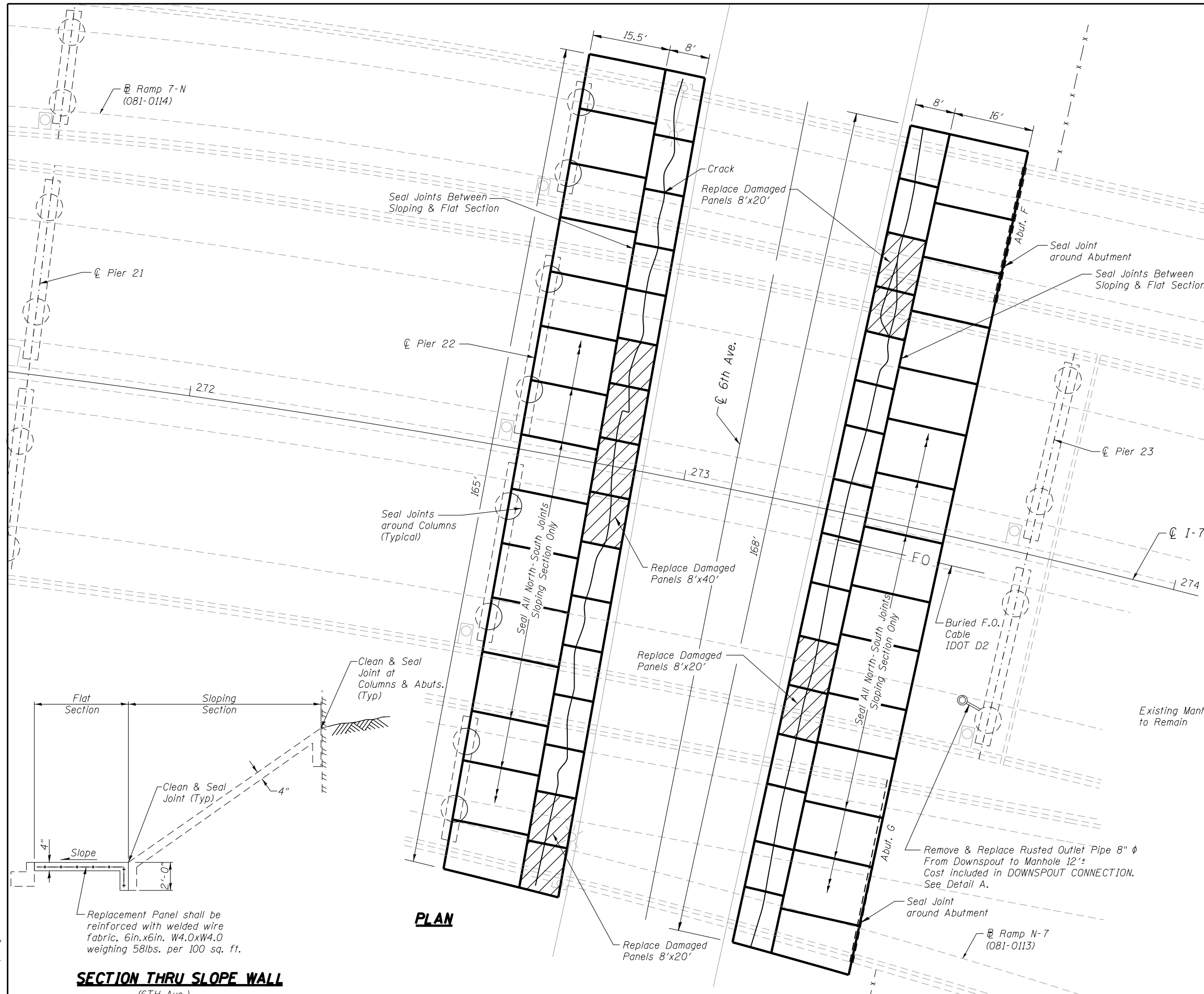
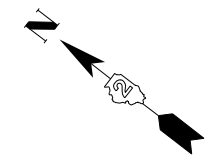

- Notes**
1. All North-South panel Joints in sloping section shall be cleaned and sealed. See Special Provisions. Cost included in SLOPE WALL CRACK SEALING.
  2. All Joints between sloping section and flat section shall be cleaned and sealed. See Special Provisions. Cost included in SLOPE WALL CRACK SEALING.
  3. All Joints between pier column and abutment walls and slope shall be cleaned and sealed. See Special Provisions. Cost included in SLOPE WALL CRACK SEALING.
  4. Slope wall surface shall be cleaned prior to repair and all debris removed. Cost included in SLOPE WALL CRACK SEALING.
  5. Damaged panels to be removed and replaced shall include the entire panel from Joint to Joint.

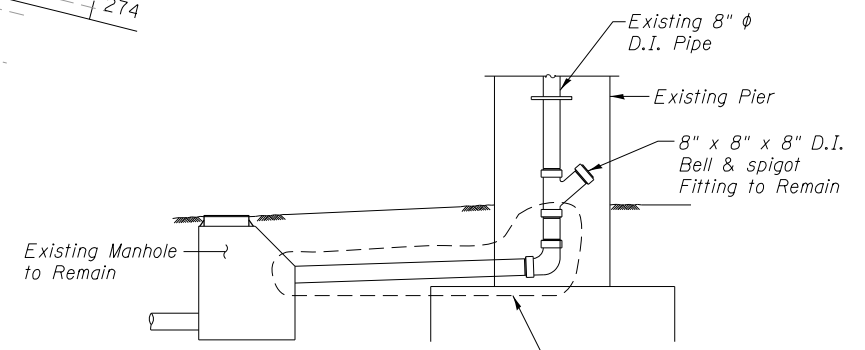

- DETAIL A**
- Limits of DOWNSPOUT CONNECTION shall include:
- Vertical Pipe below Y
  - 90° Elbow
  - Horizontal Pipe to manhole
  - Connection to downspout & manhole

**BILL OF MATERIAL**

Item	Unit	Total
Slope Wall Removal	Sq Yd	89
Slope Wall 4 Inch	Sq Yd	89
Slope Wall Crack Sealing	Foot	893
Downspout Connection	Each	1

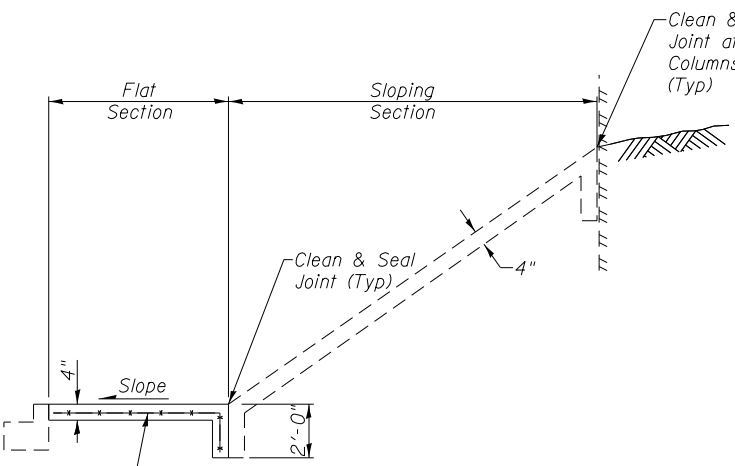

**SECTION THRU SLOPE WALL**  
(6TH Ave.)

Replacement Panel shall be reinforced with welded wire fabric, 6in.x6in. W4.0xW4.0 weighing 58lbs. per 100 sq. ft.

FILE NAME = \\Quigg\Projects\Projects\2012\JOBS\12-92-09\PTB 164 11 02 1-74 Bridge Repairs-Traffic Control Plans\CADD\CADD Sheets\081-0142-0143-64H83-020-SlopeWall\Repair-02.dgn  
 MODEL = Default  
 PLOT DRIVER = 12-92-091.PDF.plt



USER NAME =	DESIGNED - MJK	REVISED
	CHECKED - DRB	REVISED
PLOT SCALE =	DRAWN - TRF	REVISED
PLOT DATE =	CHECKED - SCD	REVISED

**STATE OF ILLINOIS**  
**DEPARTMENT OF TRANSPORTATION**

**SLOPE WALL REPAIR - 6TH AVE.**  
**STRUCTURE NO. 081-0142 & 081-0143 & 081-0113 & 081-0114**

SHEET NO. 20 OF 20 SHEETS

F.A.I. RTE.	SECTION	COUNTY	TOTAL SHEETS	SHEET NO.
74	181-IHVB & 81-IHVB-1M-3	ROCK ISLAND	69	69
CONTRACT NO. 64H83				
ILLINOIS FED. AID PROJECT				