

Hexagon locknut and washer (top), leveling nut and washer (bottom). Galvanize per AASHTO M232. Nuts shall each be tightened against base plate with 200 lb.-ft. minimum torque.

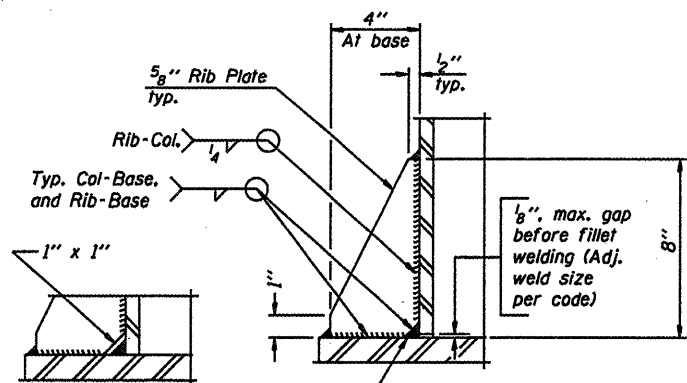

Alternate detail if welding col. to base plate first, then snip inside corner of ribs. Terminate weld on rib 1/4" from snip.

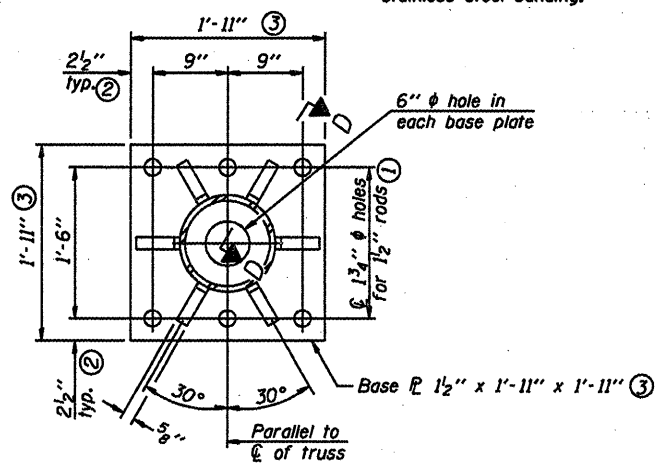
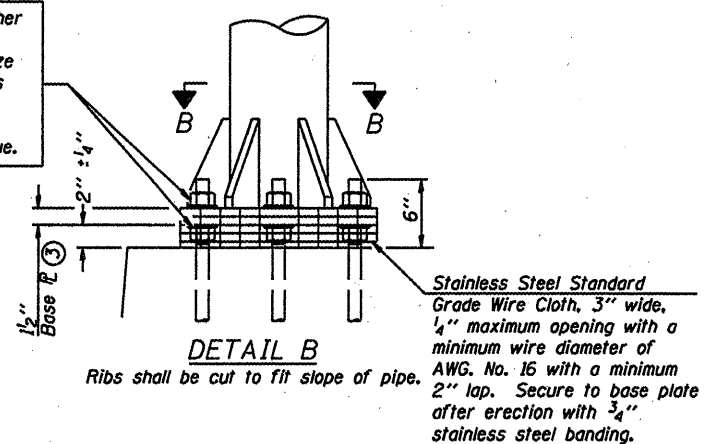
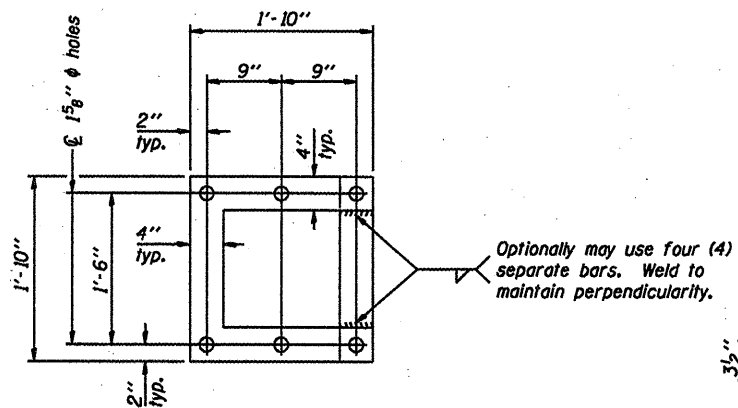

At each location, provide 1/4" thick positioning plate(s) and six (6) additional nuts to be used with leveling nuts to maintain anchor bolts position during concrete placement.

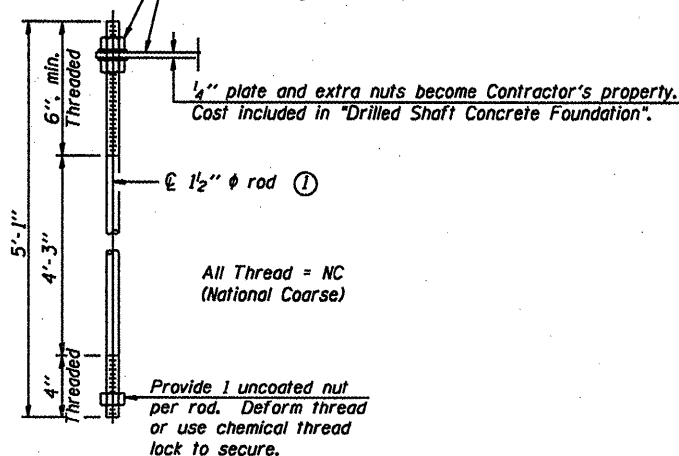

**ANCHOR ROD DETAIL**

Anchor rods shall conform to AASHTO M314 Grade 36 or 55 and meet Charpy V-Notch (CVN) energy of 15 lb.-ft. at 40° F. Galvanize upper 12" per AASHTO M232. No welding shall be permitted on rods.

**TYPE III-A TRUSS  
12"  $\phi$  PIPE SUPPORT FRAME DETAILS**

Notes:  
For Type III-A Truss spans greater than 150 ft. and up to 160 ft.:

- ① 1 3/4"  $\phi$  rod, 2"  $\phi$  holes
- ② 2 3/4" edge distance
- ③ Base P 1 5/8" x 1'-11 1/2" x 1'-11 1/2"

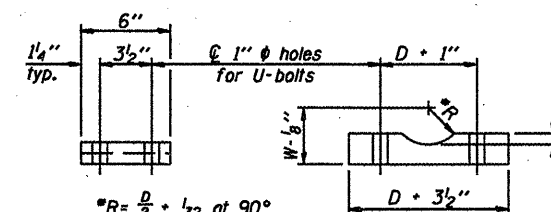
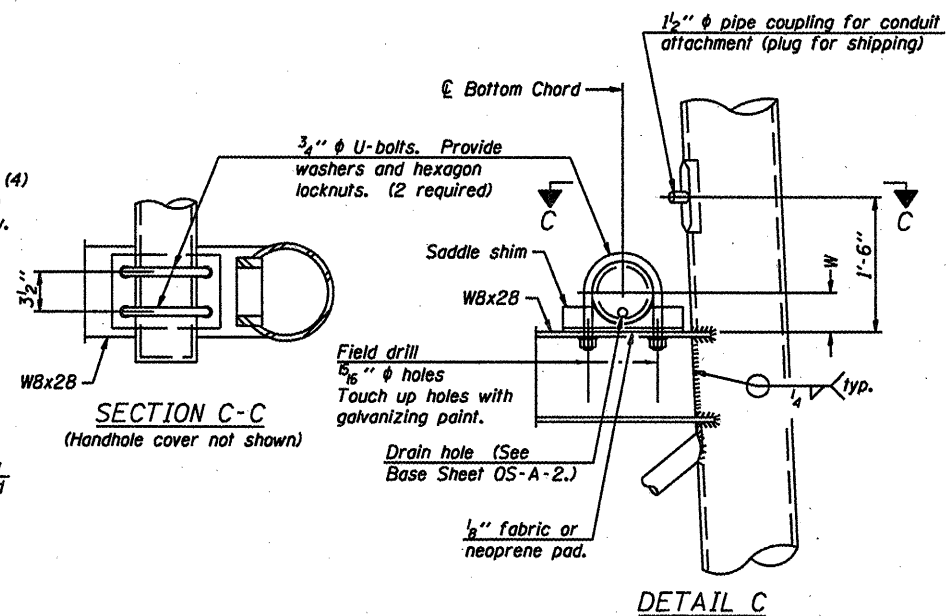

Truss Chord Nominal Dia.	a
7"	1"
8 1/2"	1 1/4"
9"	1 3/8"

**SADDLE SHIM DETAIL**  
ASTM B26 Alloy 356-F  
or  
ASTM B209 Alloy 6061-T651  
(4 required per sign truss)

**OVERHEAD SIGN STRUCTURES  
SUPPORT FRAME for TYPE III-A ALUMINUM TRUSS**

District 6  
Overhead Sign Structure  
Replacement

DESIGNED -	20
CHECKED -	EXAMINED
DRAWN -	PASSED
CHECKED -	ENGINEER OF BRIDGES AND STRUCTURES

NUMBER	REVISION	DATE