

When "A" is 3'-6" or less, the temporary concrete barrier shall be anchored to the new slab according to Detail I or Detail II. No anchorage is required when "A" is greater than 3'-6".

When "A" is 1'-1 1/2" (N. edge of deck during Stage II), the temporary concrete barrier shall be anchored to the new slab using 1" dowels bars using the detail for securing temporary concrete barriers to existing slabs.

NOTES

Detail I - With Bar Splicer or Couplers:
Connect one (1) 1"x7"x11" steel PL to the top layer of couplers with 2-5/8" φ bolts screwed to coupler at approximate CL of each barrier panel.

Detail II - With Extended Reinforcement Bars:
Connect one (1) 1"x7"x11" steel PL to the concrete slab or concrete wearing surface with 2-5/8" φ Expansion Anchors or cast in place inserts spaced between the top layer of reinforcement at approximate CL of each barrier panel.

Cost of anchorage is included with Temporary Concrete Barrier. The 1" x 7" x 11" plate shall not be removed until stage II construction forms and all reinforcement bars are in place and the concrete is ready to be placed.

SECTIONS THRU SLAB

***Dimension shown is minimum required embedment into concrete. If hot-mix asphalt wearing surface is present, minimum embedment shall be in addition to wearing surface depth.

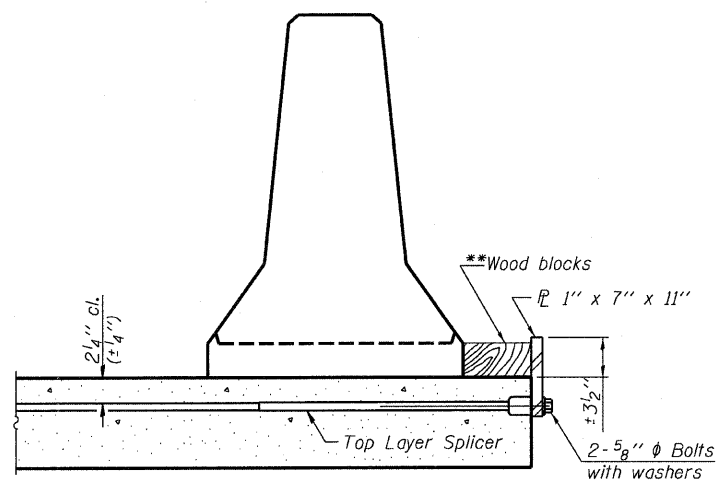

DETAIL I

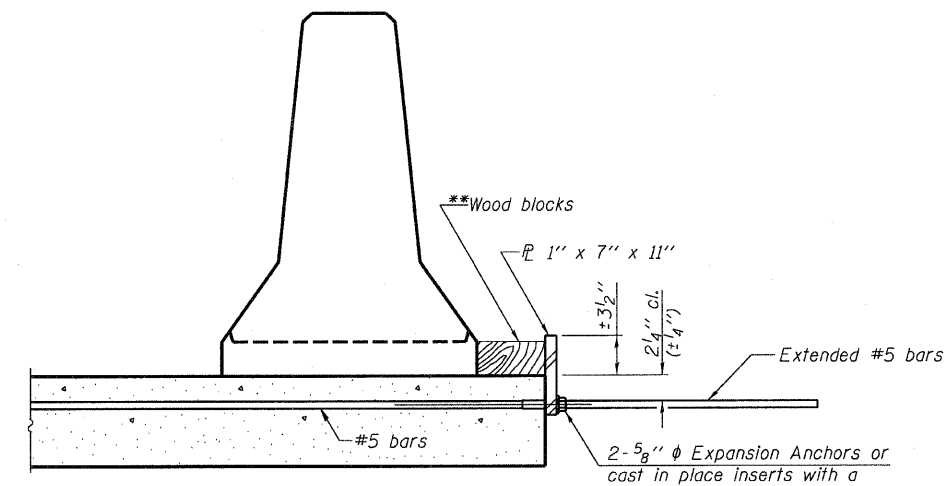

DETAIL II

**Wood blocks may be omitted when required to provide minimum stage traffic lane width. When the wood blocks are omitted, the concrete barrier shall be in direct contact with the steel retainer plate.

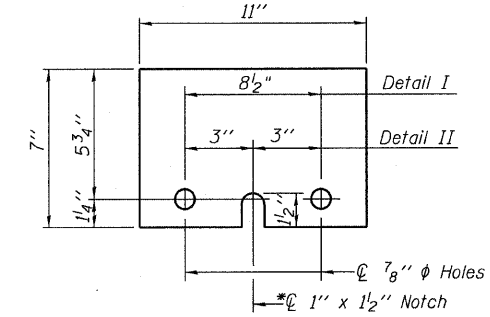

STEEL RETAINER PL 1" x 7" x 11"

* Required only with Detail II

Note:
For quantity of Temporary Concrete Barrier, see roadway plans.

REVISIONS	
NAME	DATE

ILLINOIS DEPARTMENT OF TRANSPORTATION
TEMPORARY CONCRETE BARRIER
FOR STAGE CONSTRUCTION
31 ST. STREET OVER KILBOURN AVE.
F.A.U. ROUTE 1463 SECTION 159-1010.1B
COOK COUNTY
STATION 223+67.45
STR. NO. 016-0872

SCALE: VERT. DRAWN BY JHR
HORIZ. CHECKED BY CLS
DATE JANUARY 2008