

CONTRACT #63078

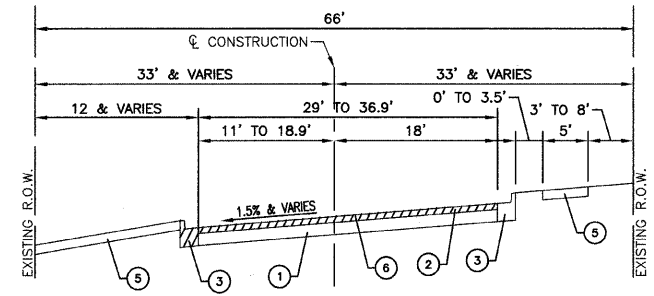

EXISTING TYPICAL SECTION
STA. 39+50 TO STA. 43+09.05

- EXISTING LEGEND**
- ① EXISTING PAVEMENT - 9.5" TO 12"
 - ② HMA SURFACE REMOVAL - 1.5" & VARIABLE
 - ③ COMB. CONC. CURB & GUTTER, TYPE B-6.18
 - ④ HMA SHOULDER
 - ⑤ PCC SIDEWALK
 - ⑥ STRIP REFLECTIVE CRACK CONTROL TREATMENT SYSTEM A
 - ▨ ITEM TO BE REMOVED

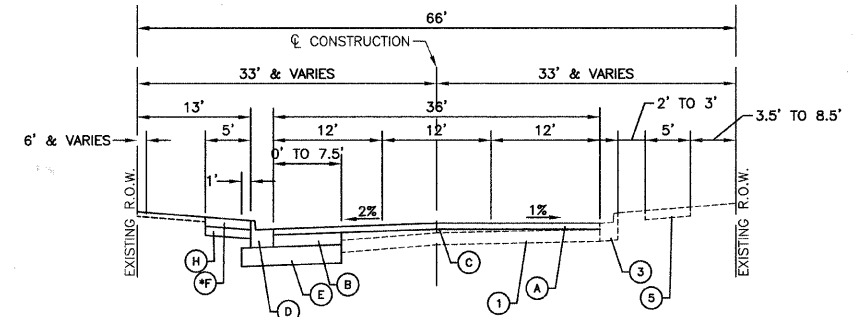

PROPOSED TYPICAL SECTION
STA. 39+50 TO STA. 43+09.06

*PAVEMENT REMOVAL FROM 32+50 TO 35+50

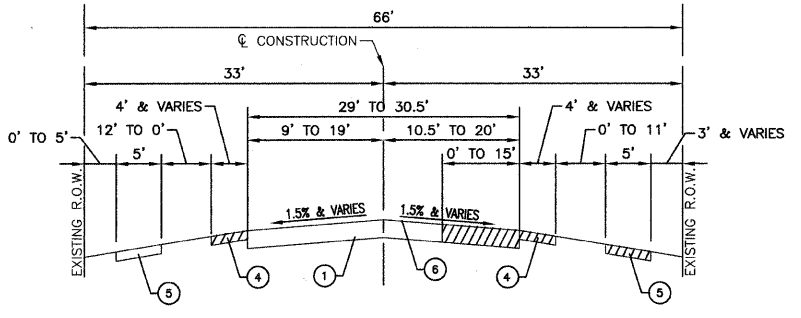

EXISTING TYPICAL SECTION
STA. 33+50 TO STA. 37+00

- PROPOSED LEGEND**
- Ⓐ HOT-MIX ASPHALT SURFACE COURSE, MIX "D", N70, 2"
 - Ⓑ HOT-MIX ASPHALT BINDER COURSE, IL 19.0, N70, 10"
 - Ⓒ LEVELING BINDER (MACHINE METHOD), IL-4.75, N50, 3/4" & VARIES
 - Ⓓ COMBINATION CONCRETE CURB AND GUTTER TYPE B-6.24
 - Ⓔ AGGREGATE SUBGRADE, 12"
 - Ⓕ PORTLAND CEMENT CONCRETE SIDEWALK, 5"
 - Ⓖ TOPSOIL FURNISH AND PLACE, 4" - SEEDING, CLASS 2A & EROSION CONTROL BLANKET OR SODDING, SALT TOLERANT
 - Ⓗ AGGREGATE BASE COURSE, TYPE B, 4"

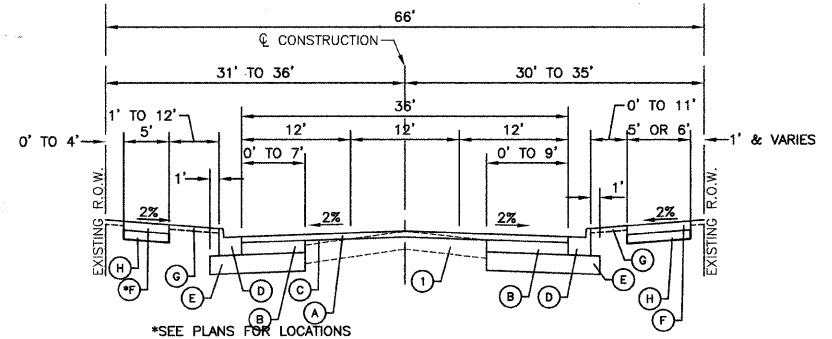

PROPOSED TYPICAL SECTION
STA. 32+86.40 TO STA. 39+50

*PAVEMENT REMOVAL FROM 32+50 TO 35+50

EARTHWORK QUANTITIES

TOTAL CUT=	2399 CY
TOTAL TOPSOIL (ESTIMATED)=	800 CY
TOTAL AVAILABLE CUT TO FILL =	1599 CY
TOTAL FILL =	480 CY
CUT TO FILL (15% SHRINKAGE) =	552 CY

SOILS NOTE:

A QUANTITY FOR POROUS GRANULAR EMBANKMENT, SUBGRADE HAS BEEN INCLUDED FOR LOCATIONS OF SOILS WHICH TEND TO BE UNSTABLE WHEN WET. THE ACTUAL NEED FOR REMOVAL AND REPLACEMENT WITH POROUS GRANULAR EMBANKMENT, SUBGRADE WILL BE DETERMINED IN THE FIELD AT THE TIME OF CONSTRUCTION BY THE ENGINEER. IF UNSTABLE AND/OR UNSUITABLE MATERIALS ARE ENCOUNTERED, THE SOILS SHALL BE REMOVED AND REPLACED WITH POROUS GRANULAR EMBANKMENT, SUBGRADE. IF UNSTABLE OR UNSUITABLE SOILS ARE NOT ENCOUNTERED, THEN THE QUANTITY SHALL BE DEDUCTED AND NO ADDITIONAL COMPENSATION WILL BE DUE THE CONTRACTOR.

REVISIONS

NAME	DATE

ILLINOIS DEPARTMENT OF TRANSPORTATION
**MAIN STREET IMPROVEMENTS
NORTH MAIN STREET TO CAMPBELL STREET
TYPICAL CROSS SECTIONS**

SCALE: VERT. NA
HORIZ. NA
DATE: 7-24-08
DRAWN BY: PS/AY
CHECKED BY: WPD