

STATE OF ILLINOIS  
DEPARTMENT OF TRANSPORTATION

ROUTE NO.	SECTION	COUNTY	TOTAL SHEETS	SHEET NO.	SHEET NO. 15
FAP 308	109BR-5	WHITESIDE	83	49	19 SHEETS
FED. AID DIST. NO. 7	ILLINOIS	FED. AID PROJECT			

Contract #64C25

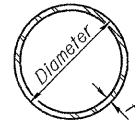

**METAL SHELL PILE TABLE**

Designation and outside diameter	Wall thickness t	Weight per foot (Lbs./ft.)	Inside volume (yd. <sup>3</sup> /ft.)
PP12	0.179"	22.60	0.0274
PP12	0.250"	31.37	0.0267
PP14	0.250"	36.71	0.0368
PP14	0.312"	45.61	0.0361

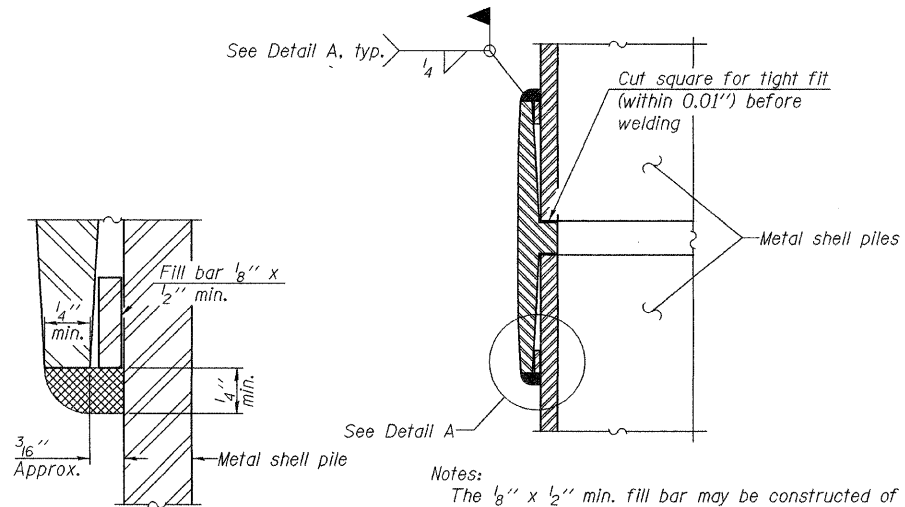

**DETAIL A**

**WELDED COMMERCIAL SPLICE**

Notes:  
The 1/8" x 1/2" min. fill bar may be constructed of 2 bars with a 1/8" max. gap between them.  
Pile segments shall be driven to solid contact with splicer before welding.

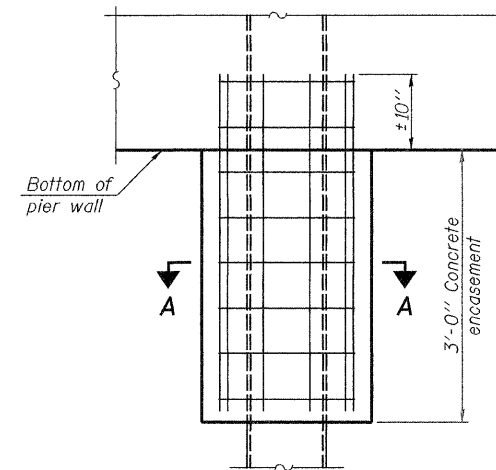

**ELEVATION**

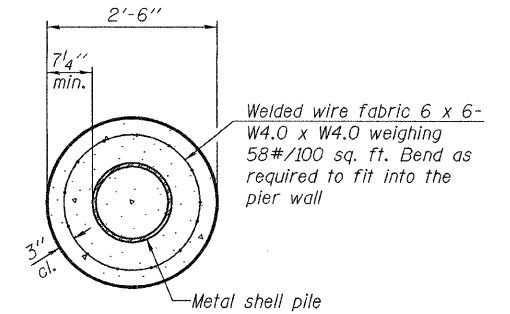

**SECTION A-A**

Note: Forms for encasement may be omitted when soil conditions permit.

**CONCRETE ENCASEMENT AT PIERS**

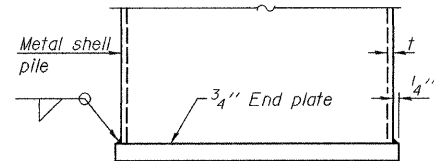

**END PLATE ATTACHMENT**

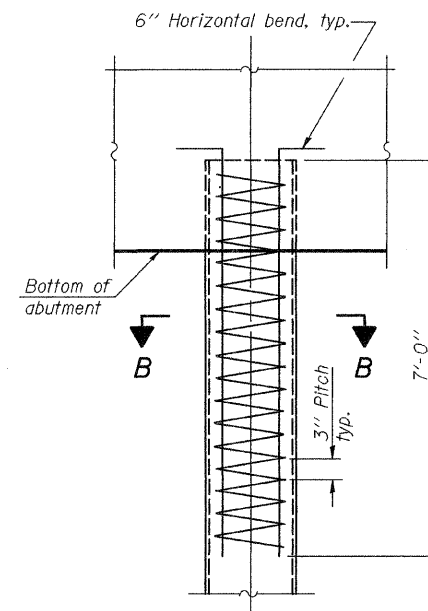

**ELEVATION**

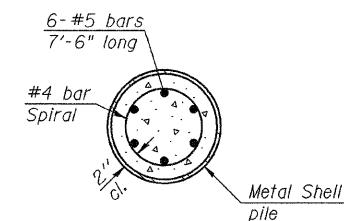

**SECTION B-B**

**METAL SHELL REINFORCEMENT AT ABUTMENTS**

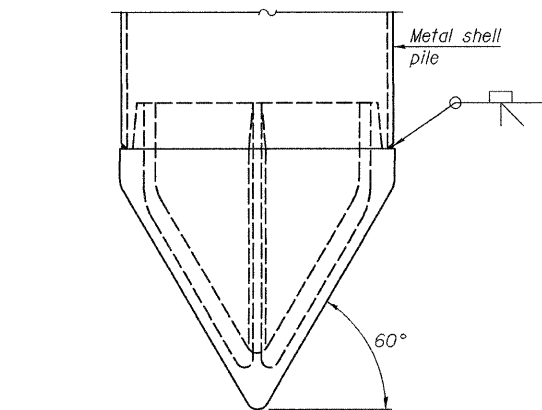

**METAL SHELL PILE SHOE ATTACHMENT**

(See Note A)

Note A:  
When called for on the plans, the Contractor shall furnish metal shell pile shoes consisting of a single piece conical pile point as shown. The pile shoes shall be cast in one piece steel according to either ASTM A 148 Grade 90-60 or AASHTO M 103 Grade 65-35 and shall provide full bearing over the full circumference of the metal shell pile. The pile shoe shall have tapered leads to assure proper alignment and fitting and shall be secured to the pile with a circumferential weld.

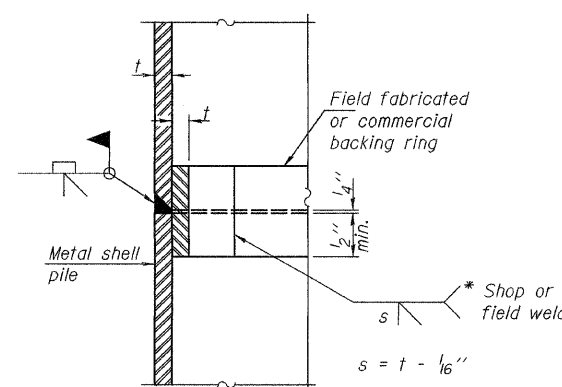

**COMPLETE PENETRATION WELD SPLICE**

\* Field fabricated backing ring may be made from pile shell by removing segment to allow reducing circumference and vertically rejoin with partial joint penetration weld.

Note: The metal shell piles shall be according to ASTM A 252 Grade 3.

DESIGNED	Dewey H. Coultas
CHECKED	Stephen M. Ryan
DRAWN	BECKY M. LEACH
CHECKED	DHC/SMR

September 2, 2008
EXAMINED <i>Thomas J. Domagala</i>
PASSED <i>Ralph E. Anderson</i>

F-MS 5-16-08

**METAL SHELL PILE DETAILS**  
**F.A.P. ROUTE 308 - SECTION 109BR-5**  
**WHITESIDE COUNTY**  
**STATION 344+76.69**  
**STRUCTURE NO. 098-0114**