

WITNESS MARKER FOR PERMANENT SURVEY MARKERS, TYPE II

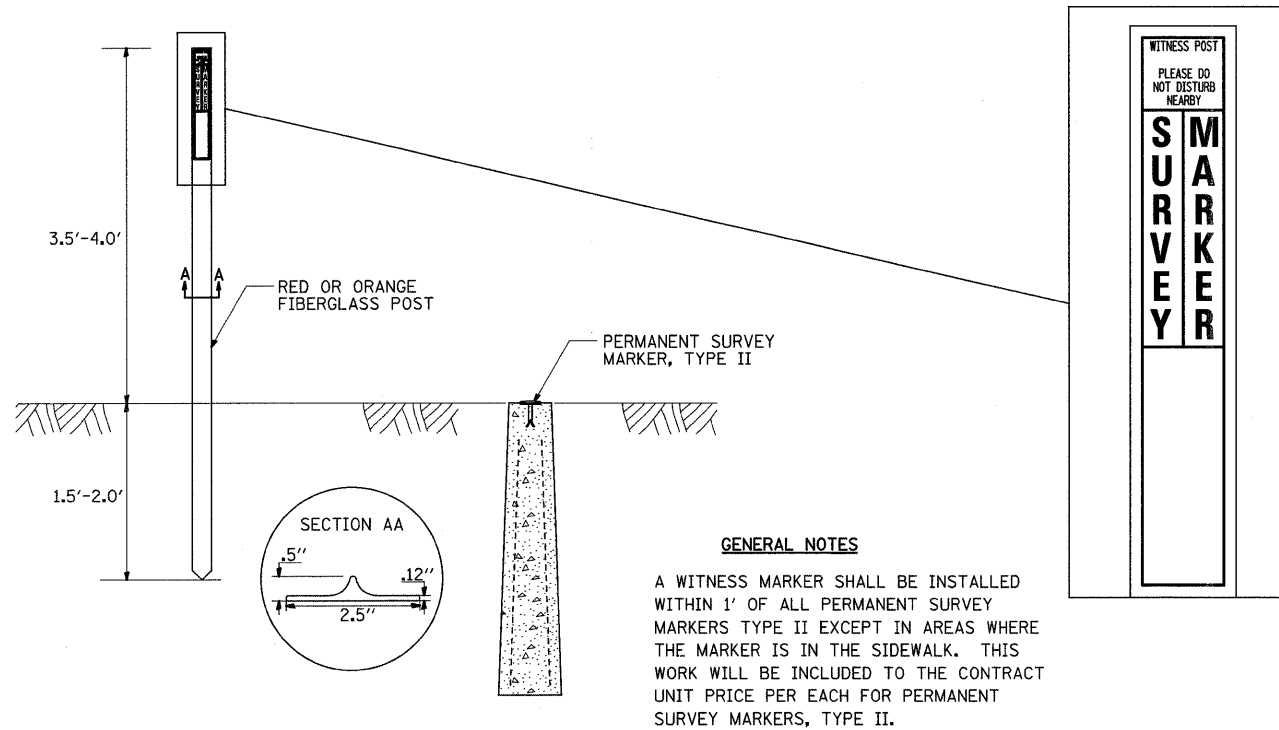

TWO CENTER CURVE DATA

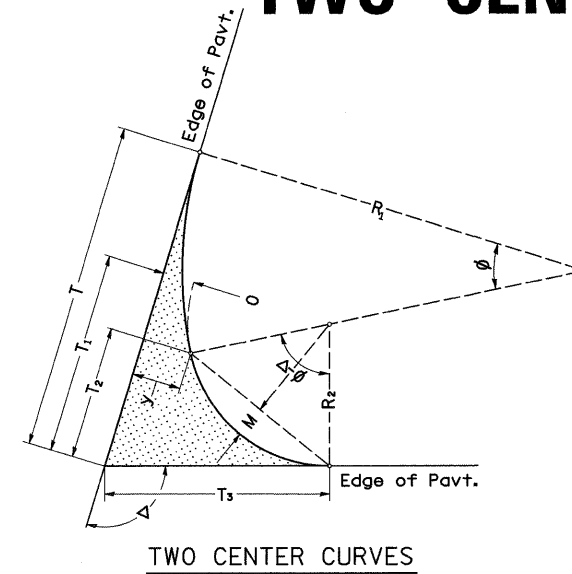

| CURVE # | 1 | | | | | | |
|----------------|--------|--|--|--|--|--|--|
| R ₁ | 230.00 | | | | | | |
| R ₂ | 30.00 | | | | | | |
| O | 15.00 | | | | | | |
| Δ | 136.20 | | | | | | |
| T | 166.26 | | | | | | |
| T ₁ | 90.27 | | | | | | |
| T ₂ | 78.87 | | | | | | |
| T ₃ | 96.30 | | | | | | |
| y | 17.25 | | | | | | |
| 4y/9 | 7.67 | | | | | | |
| y/9 | 1.92 | | | | | | |
| M | 13.63 | | | | | | |
| ISM | 12.78 | | | | | | |
| SM | 10.22 | | | | | | |
| TM | 5.96 | | | | | | |
| C | 50.28 | | | | | | |

ALL DIMENSIONS ARE IN MILLIMETERS (INCHES) UNLESS OTHERWISE NOTED.

PERMANENT SURVEY MARKERS, TYPE II

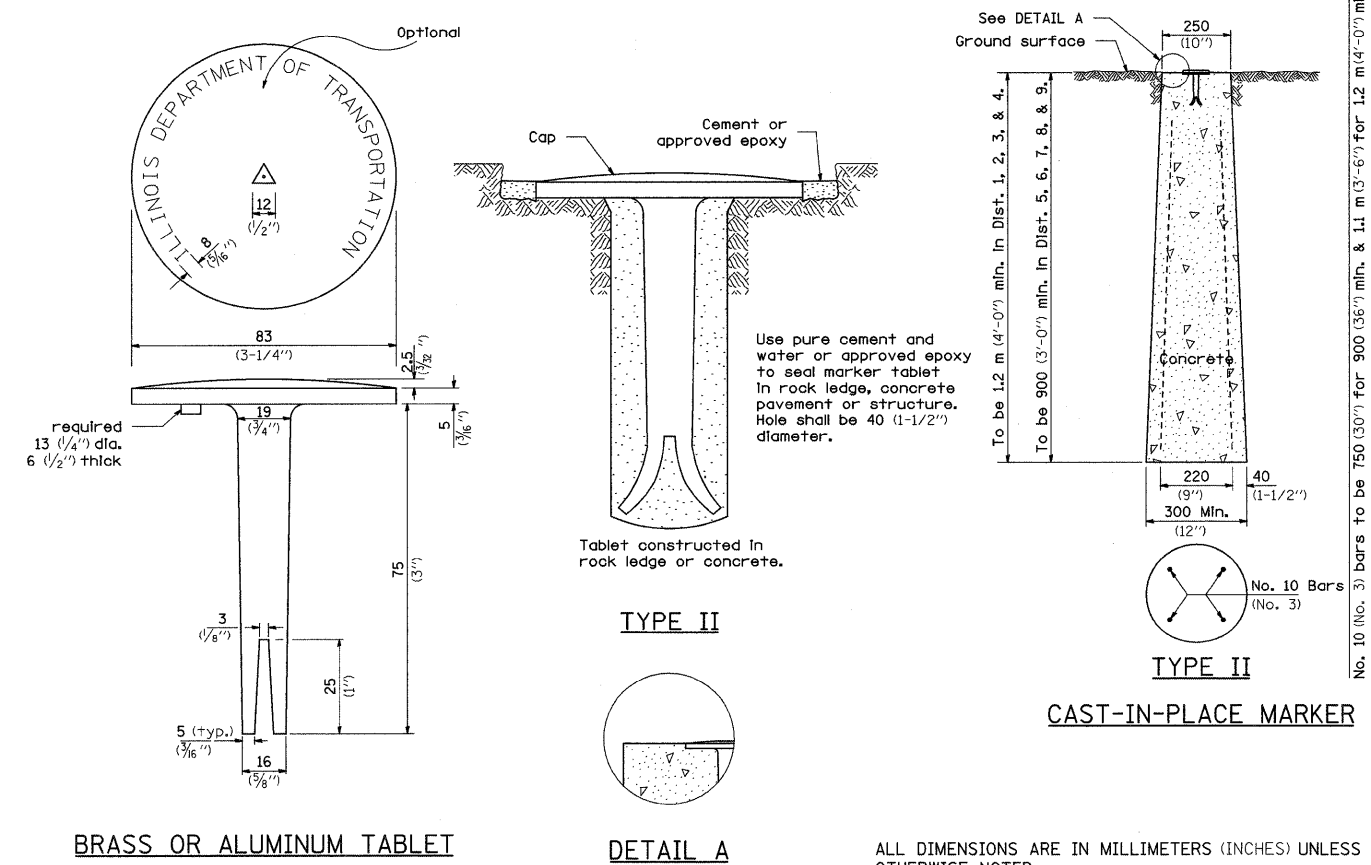

ALL DIMENSIONS ARE IN MILLIMETERS (INCHES) UNLESS OTHERWISE NOTED.

REVISED - 6-26-06

| | | | | | | |
|-------------------|--------------------------------|---|---------|-----------|--------------|-----------|
| REVISED - 3-22-90 | REGION 2 / DISTRICT 2 STANDARD | F.A.P. RTE. | SECTION | COUNTY | TOTAL SHEETS | SHEET NO. |
| REVISED - | | 308 | 109BR-5 | WHITESIDE | 83 | 66 |
| REVISED - | | CONTRACT NO. 64C25 | | | | |
| REVISED - | | FED. ROAD DIST. NO. ILLINOIS FED. AID PROJECT | | | | |