

STATE OF ILLINOIS
DEPARTMENT OF TRANSPORTATION

CONTRACT NO. 98542				
F.A.S. RTE	SECTION	COUNTY	TOTAL SHEETS	SHEET NO
932	(8,9,11)W,RS-1		401	163
STA.		TO STA.		
FED. ROAD DIST. NO.	ILLINOIS	FED. AID PROJECT		
• JOHNSON/POPE				

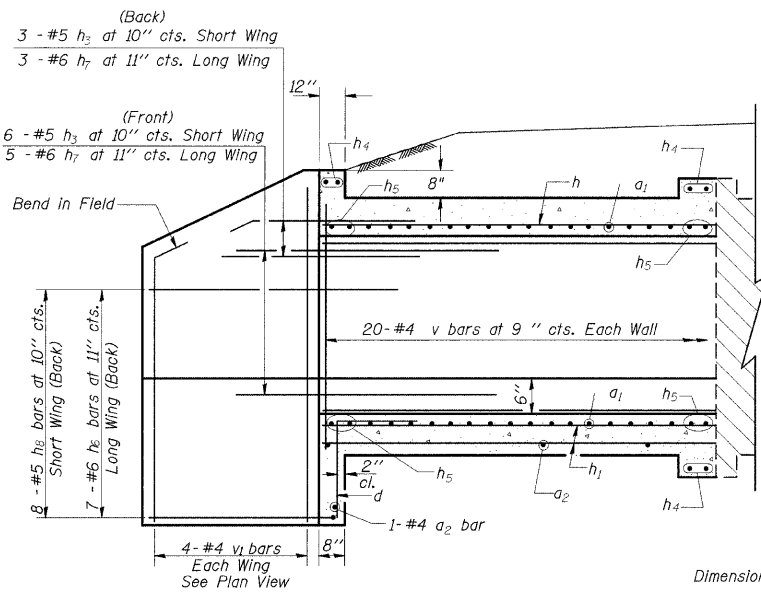

HALF LONG. SECTION

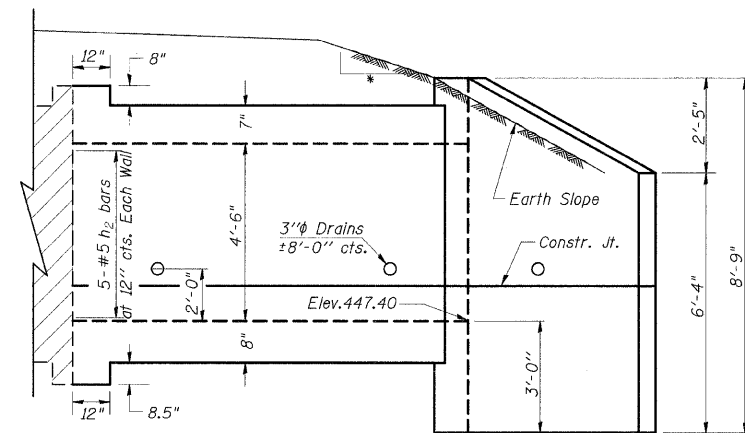

HALF ELEVATION

- 4:1 TO CLEAR ZONE
- 3:1 AFTER CLEAR ZONE

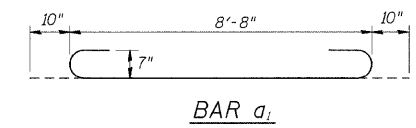
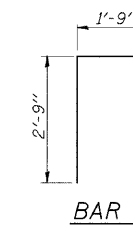
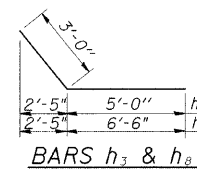

DESIGN STRESSES

$f_y = 60,000$ psi
 $f'_c = 3,500$ psi

LOADING HS 20-44 & ALT.

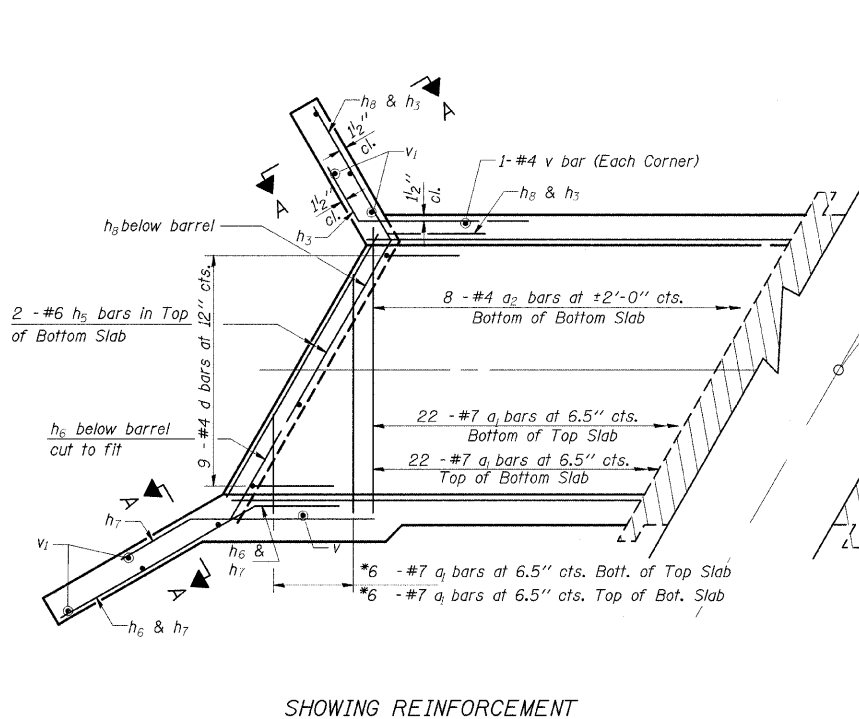
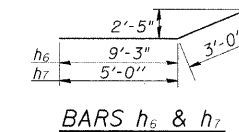

SHOWING REINFORCEMENT

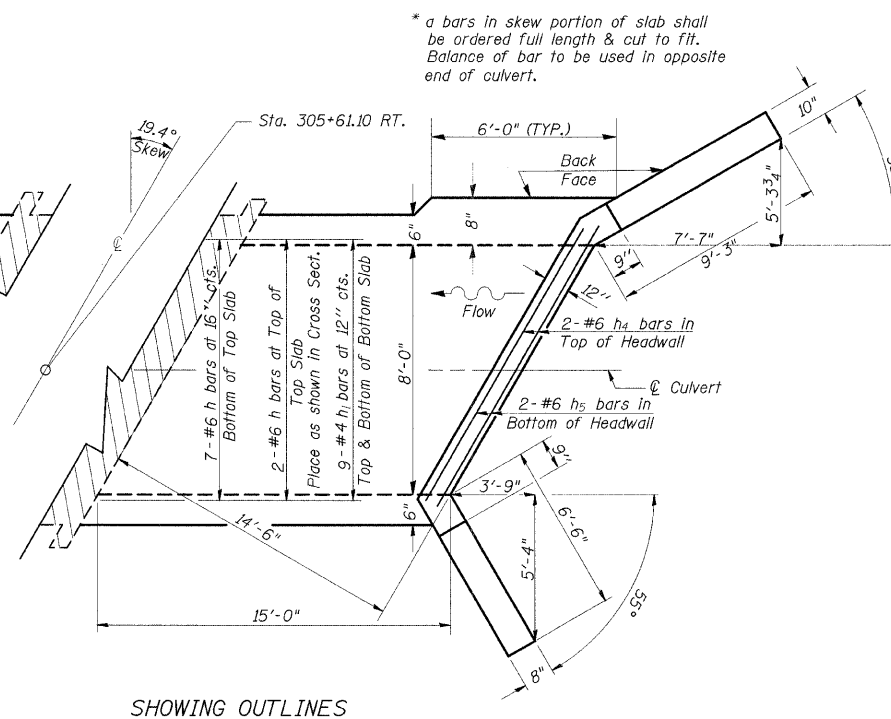

SHOWING OUTLINES

NOTES

A distance of half the length of the wingwall but not less than six feet of the barrel shall be poured monolithically with the wingwalls.
Reinforcement Bars shall conform to the requirements of AASHTO M-31, M-42 or M-53, Grade 60.
Bars indicated thus 12 x 4 - #5 etc. indicates 12 lines of bars with 4 lengths per line.
All construction joints shall be bonded.

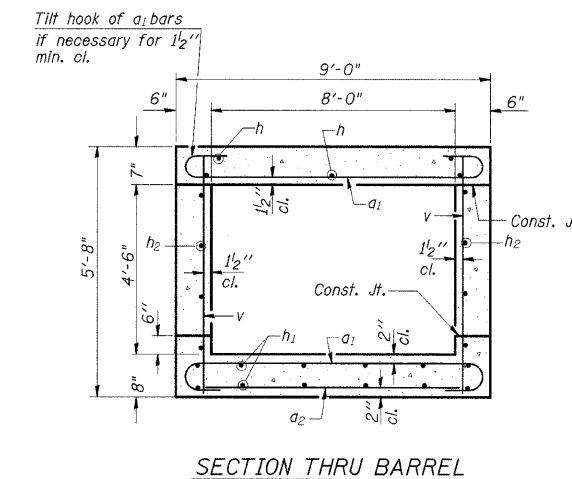

SECTION THRU BARREL

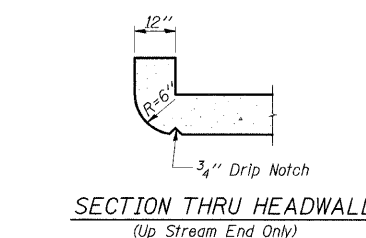
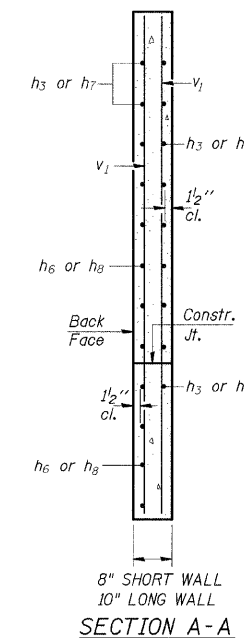

BILL OF MATERIAL

Bar	No.	Size	Length	Shape
a_1	56	#7	10'-4"	
a_2	9	#4	8'-3"	
d	9	#4	4'-6"	
h	11	#6	14'-9"	
h_1	18	#4	14'-9"	
h_2	10	#5	14'-9"	
h_3	9	#5	8'-0"	
h_4	6	#6	8'-6"	
h_5	8	#6	8'-6"	
h_6	7	#6	12'-3"	
h_7	8	#6	8'-0"	
h_8	8	#5	9'-6"	
v	42	#4	6'-0"	
v_1	8	#4	7'-5"	
Expansion Bolts 3/4"				Each 20
Concrete Box Culverts				Cu. Yd. 13.6
Reinforcement Bars				Pound 2560

PRECAST OPTION NOT ALLOWED

ILLINOIS DEPARTMENT OF TRANSPORTATION
BOX CULVERT EXTENSION
STATION 305+61.10 RT.
8' X 4.5', SKEW 19.4° RT. AH.
EXTEND 15'-0"