

FILE PATH = p:\388035\pmt\escomon\line\local\FM\W26\Documents\01\_Americas\Transportation\62629938\_Circle\Phase\_1\000\_CAD\005\_Roadway\Sheets\60W26\_Contract\0160W26-sht-WM-06.dgn

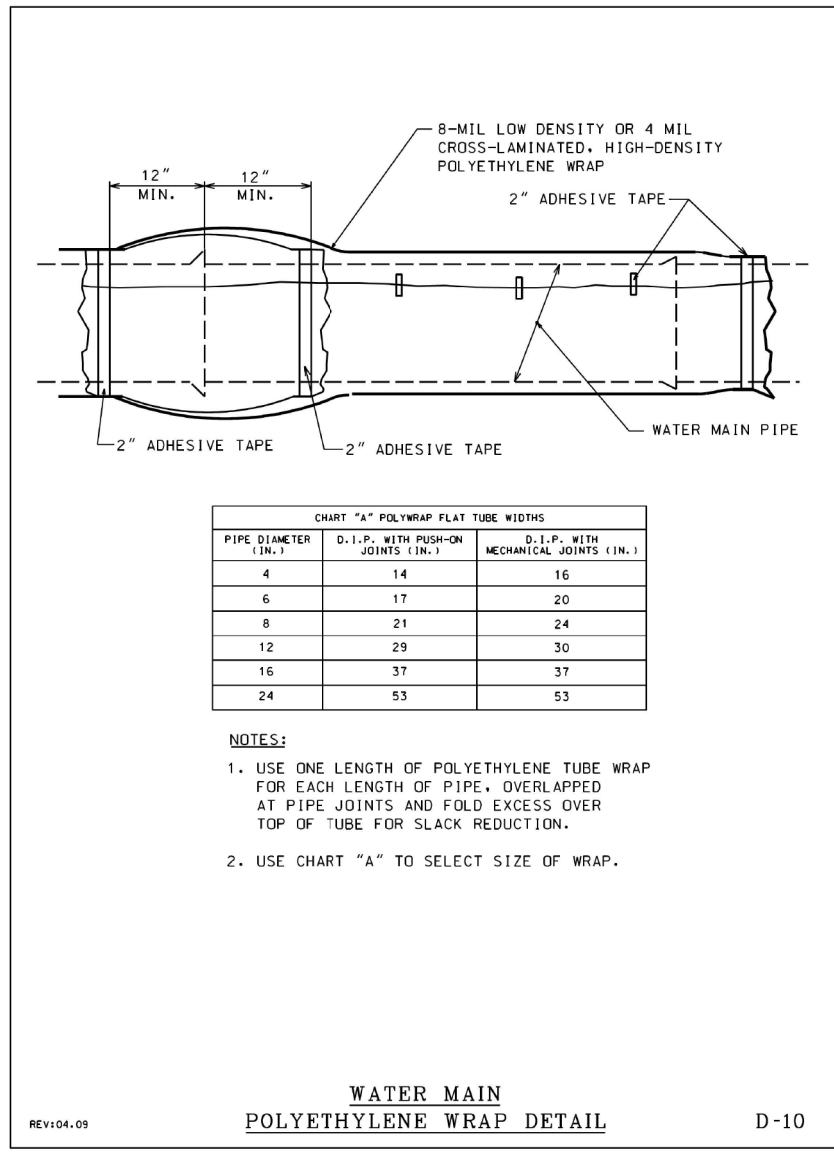
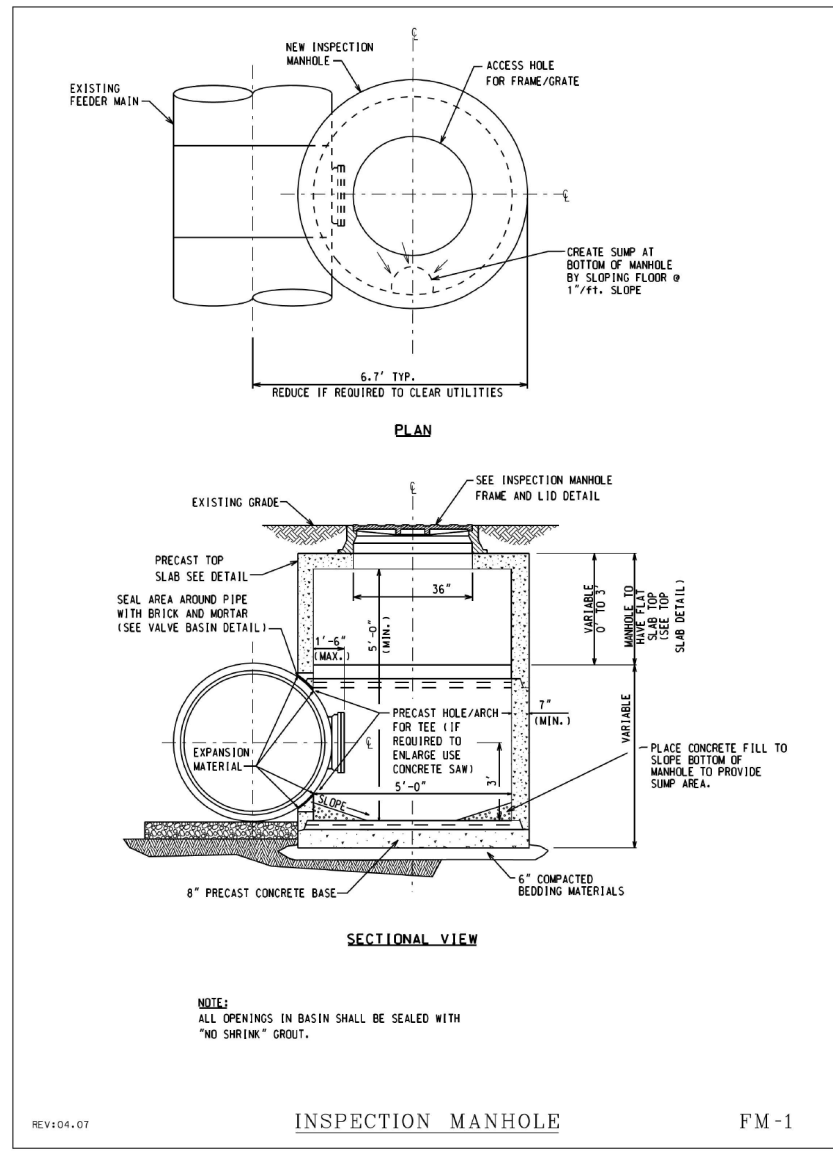

CHART "A" POLYWRAP FLAT TUBE WIDTHS

| PIPE DIAMETER (IN.) | D.I.P. WITH PUSH-ON JOINTS (IN.) | D.I.P. WITH MECHANICAL JOINTS (IN.) |
|---------------------|----------------------------------|-------------------------------------|
| 4                   | 14                               | 16                                  |
| 6                   | 17                               | 20                                  |
| 8                   | 21                               | 24                                  |
| 12                  | 29                               | 30                                  |
| 16                  | 37                               | 37                                  |
| 24                  | 53                               | 53                                  |

- NOTES:
1. USE ONE LENGTH OF POLYETHYLENE TUBE WRAP FOR EACH LENGTH OF PIPE, OVERLAPPED AT PIPE JOINTS AND FOLD EXCESS OVER TOP OF TUBE FOR SLACK REDUCTION.
  2. USE CHART "A" TO SELECT SIZE OF WRAP.

WATER MAIN  
POLYETHYLENE WRAP DETAIL  
REV:04.09 D-10



NOTE:  
ALL OPENINGS IN BASIN SHALL BE SEALED WITH "NO SHRINK" GROUT.

INSPECTION MANHOLE  
REV:04.07 FM-1

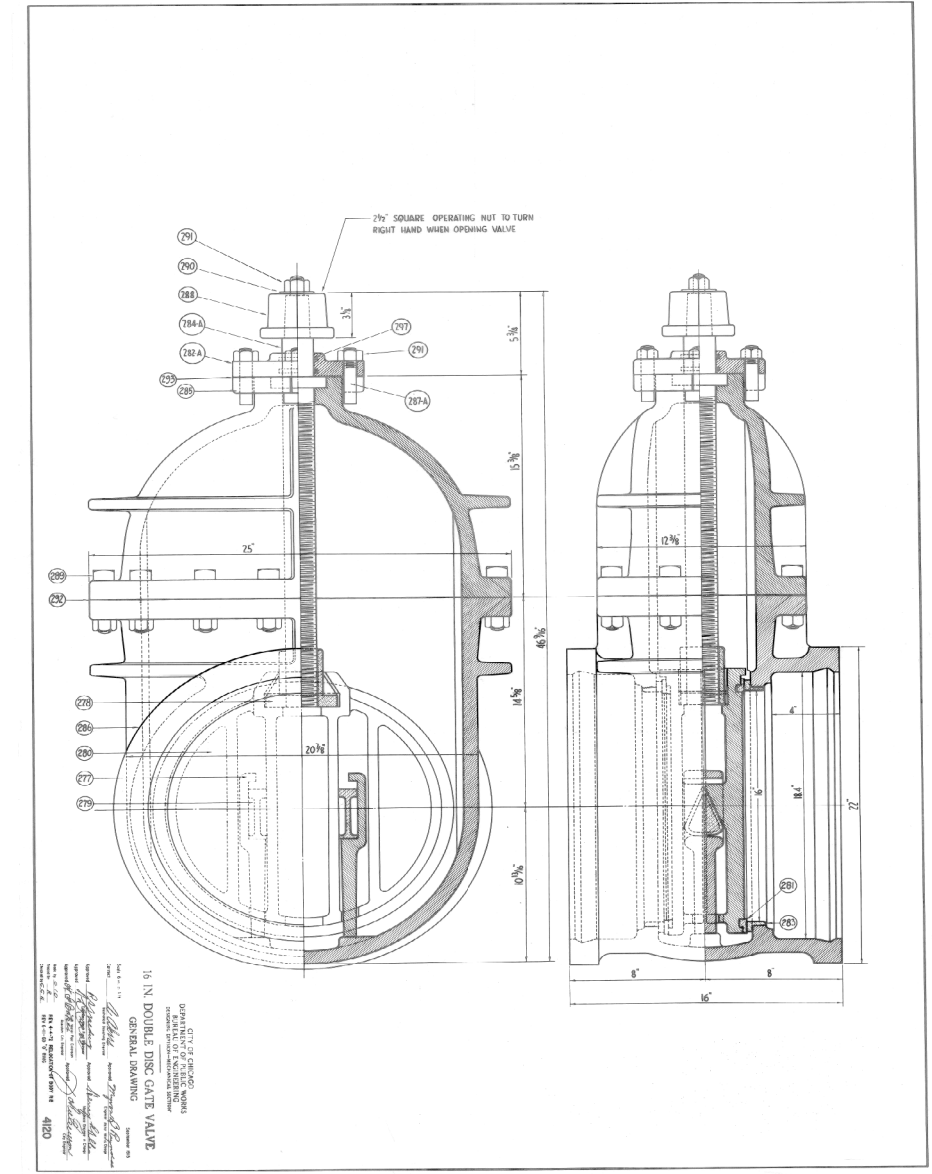

16 IN DOUBLE DISC GATE VALVE  
GENERAL DRAWING  
DRAWN BY: [Signature]  
CHECKED BY: [Signature]  
DATE: 9/15/13

WATER MAIN DETAILS

SCALE: SHEET OF SHEETS STA. TO STA.

|                           |           |        |              |           |
|---------------------------|-----------|--------|--------------|-----------|
| F.A.I. RTE.               | SECTION   | COUNTY | TOTAL SHEETS | SHEET NO. |
| 90/94/290                 | 2013-008R | COOK   | 559          | 145       |
| CONTRACT NO. 60W26        |           |        |              |           |
| ILLINOIS FED. AID PROJECT |           |        |              |           |



D160W26-sht-WM-06.dgn  
USER NAME = CooperM2  
PLOT SCALE = 20.0000' / in.  
PLOT DATE = 9/15/2013

DESIGNED - HHC  
DRAWN - HHC  
CHECKED - RBB  
DATE - 9/15/13

REVISED -  
REVISED -  
REVISED -  
REVISED -

STATE OF ILLINOIS  
DEPARTMENT OF TRANSPORTATION