

FILE PATH = p:\388035\pmt\escomon\me\local\AECOM\01\Documents\01\Americas\Transportation\60269938\_Circle\Phase\_1\1000\_CAD\005\_Roadway\Sheets\60W26\_Contract\0160W26-sht-WM-07A.dgn

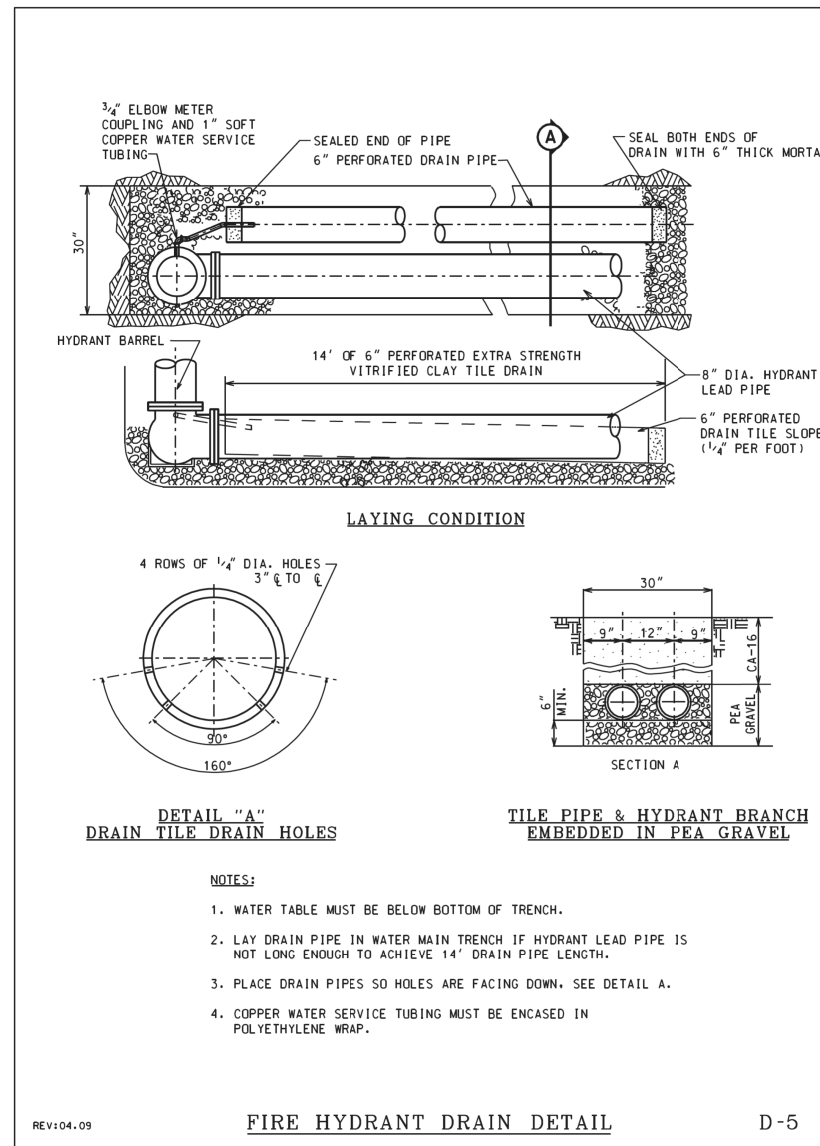
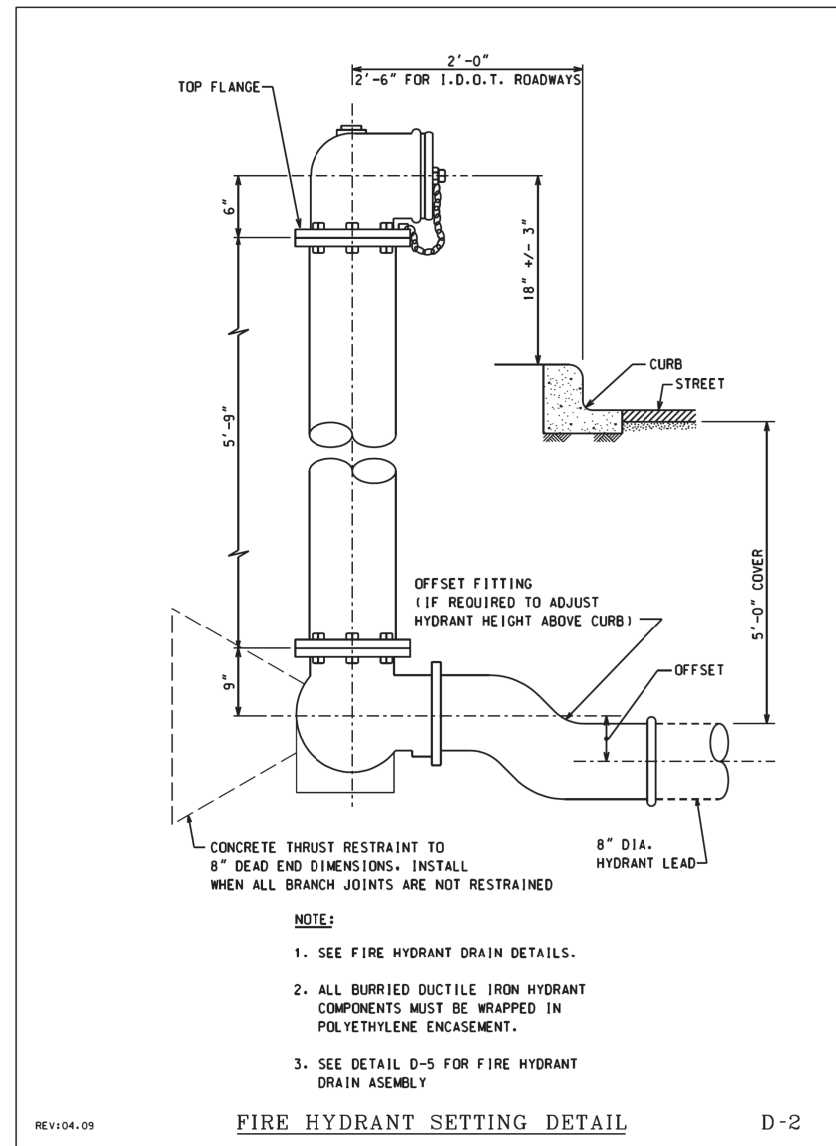

D160W26-sht-WM-07A.dgn  
USER NAME = pimsarno  
PLOT SCALE = 40.0000' / in.  
PLOT DATE = 9/15/2013

DESIGNED - HHC  
DRAWN - HHC  
CHECKED - RBB  
DATE - 9/15/13

REVISED -  
REVISED -  
REVISED -  
REVISED -

STATE OF ILLINOIS  
DEPARTMENT OF TRANSPORTATION

WATER MAIN DETAILS

SCALE: SHEET OF SHEETS STA. TO STA.

|                           |           |        |                 |              |
|---------------------------|-----------|--------|-----------------|--------------|
| F.A.I.<br>RTE.            | SECTION   | COUNTY | TOTAL<br>SHEETS | SHEET<br>NO. |
| 90/94/290                 | 2013-008R | COOK   | 559             | 146A         |
| CONTRACT NO. 60W26        |           |        |                 |              |
| ILLINOIS FED. AID PROJECT |           |        |                 |              |