

**STAGE I REMOVAL**

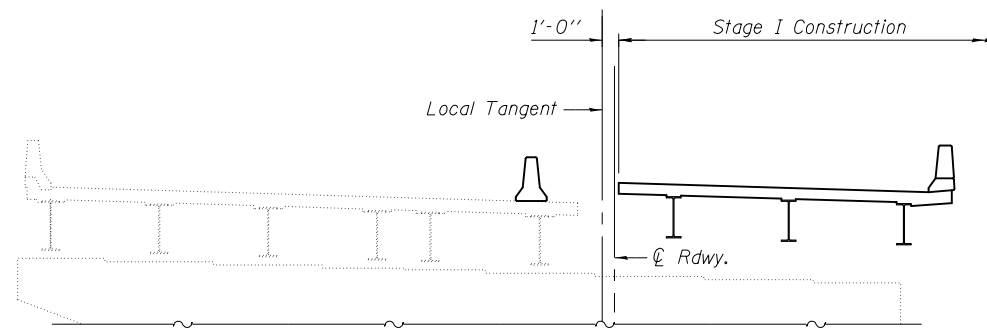

**STAGE I CONSTRUCTION**

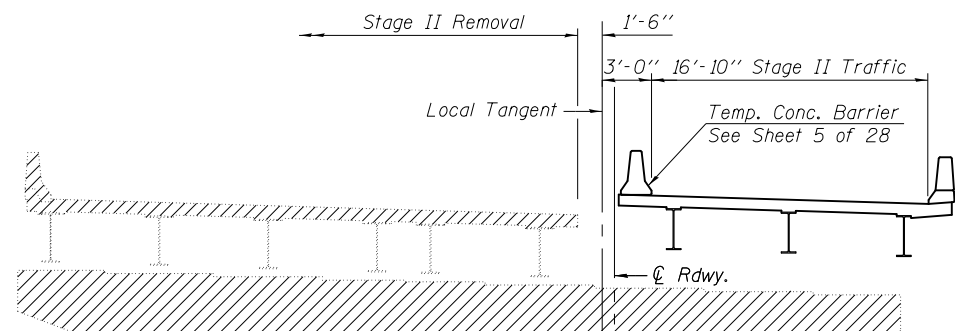

**STAGE II REMOVAL**

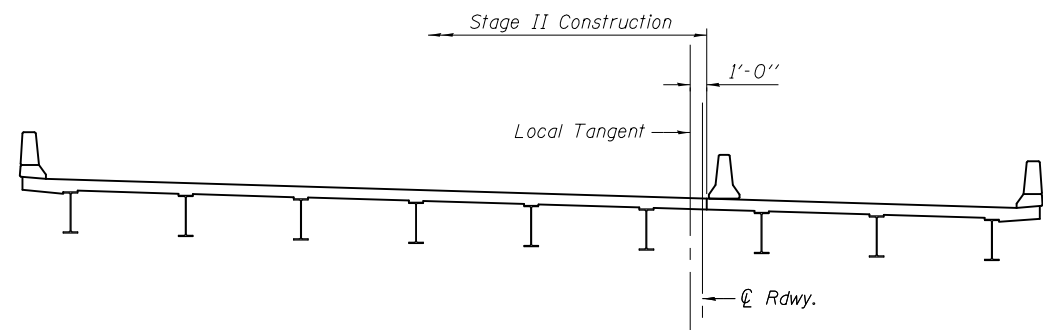

**STAGE II CONSTRUCTION**

**Staging Notes:**  
 All staging cross sections are looking South.  
 Hatched areas indicate Removal of Existing Structures.  
 See Rdwy. plans for quantity of Temporary Concrete Barrier.  
 Stage construction joint location for the pier cap and footing will differ from those shown for the superstructure. See pier sheets for these joint locations.  
 Stage I Removal shall NOT include any portion of the existing piers below the steel beam bearings. Stage I Construction will be completed over the top of the existing pier.

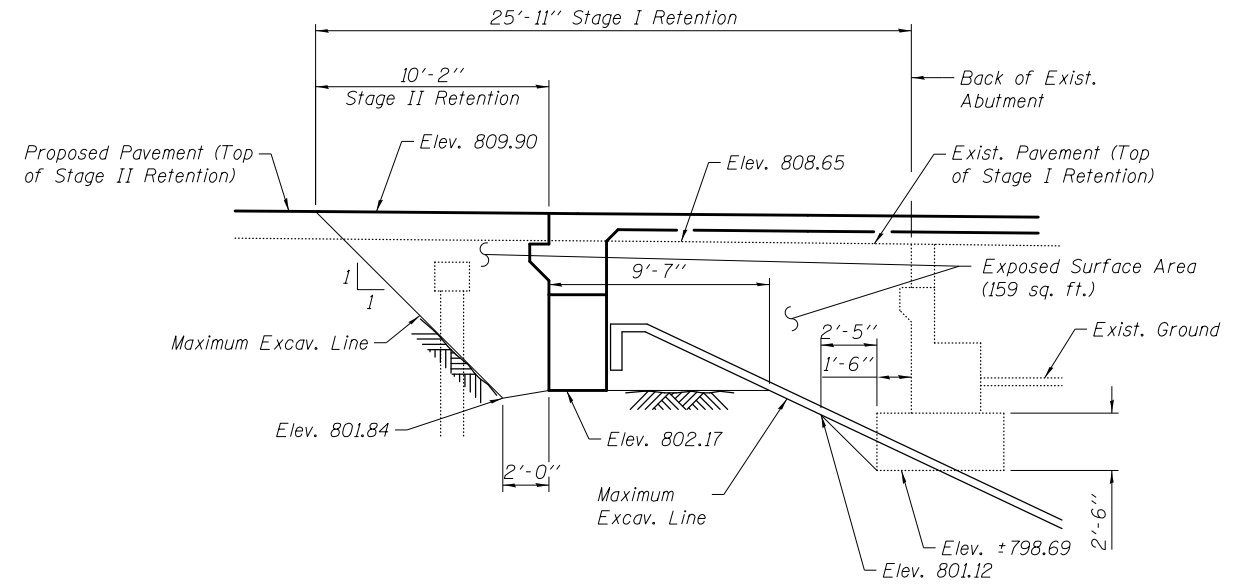

**TEMPORARY SOIL RETENTION SYSTEM**

**NORTH ABUTMENT**

(Looking East)

**Notes:**  
 Due to the potential for difficult driving conditions, a cantilevered sheet piling design does not appear feasible and additional members or other retention systems may be necessary. The Contractor shall submit a temporary soil retention system design including plan details and calculations for review and acceptance by the Engineer.  
 Dimensions and slopes are shown along the temporary soil retention unless noted otherwise.

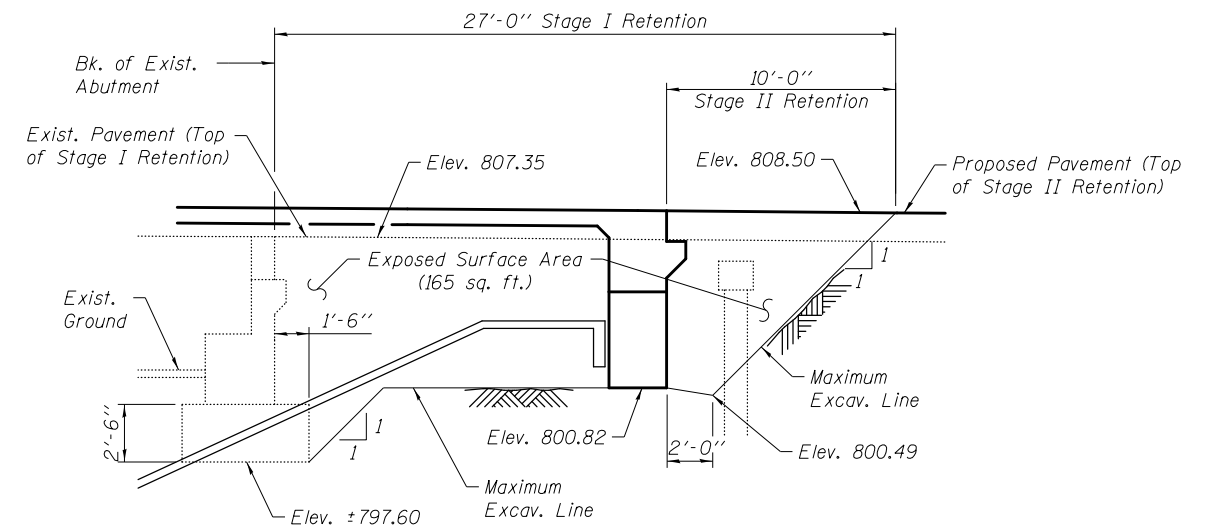

**TEMPORARY SOIL RETENTION SYSTEM**

**SOUTH ABUTMENT**

(Looking East)

FILE NAME =	USER NAME = piersonbr	DESIGNED - MJT	REVISED -
\$FILES*		CHECKED - RJP	REVISED -
		DRAWN - BAS	REVISED -
		CHECKED - MJT	REVISED -

**STATE OF ILLINOIS  
 DEPARTMENT OF TRANSPORTATION**

**STAGING CONSTRUCTION DETAILS  
 STRUCTURE NO. 057-0251**

SHEET NO. 4 OF 28 SHEETS

F.A.I. RTE.	SECTION	COUNTY	TOTAL SHEETS	SHEET NO.
74	(57-20HB-1)BR	MCLEAN	440	157
CONTRACT NO. 70570				
ILLINOIS FED. AID PROJECT				