

SECTION AT DRAIN

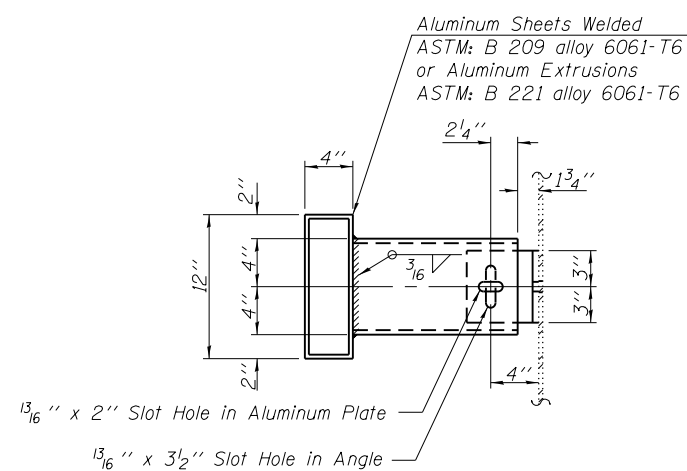

SECTION A-A

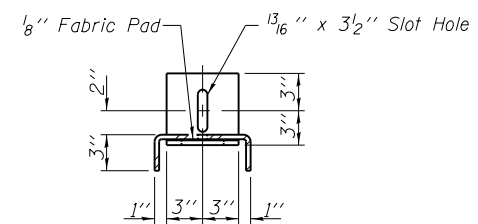

SECTION B-B

Note:
Removal and disposal of existing Drain Extensions is included in the cost of "Deck Drain Extensions".

USER NAME = *OPERATOR*	DESIGNED - TJZ	REVISED
FILE NAME = 0110514-72A61.dgn	CHECKED -	REVISED
PLOT SCALE = 0:2.0000 ' / 1"	DRAWN - DLH	REVISED
PLOT DATE = 8/16/2013	CHECKED -	REVISED

F.A.P. RTE.	SECTION	COUNTY	TOTAL SHEETS	SHEET NO.
•	4(I)	CHRISTIAN	97	72A
• 75 (IL 27) & 714 (IL 48)			CONTRACT NO. 72A61	