

When cantilever forming brackets are used, the work shall be done according to Article 503.06(b) of the Standard Specifications, except as modified below and in the details shown on this sheet.

The finishing machine rails shall be placed on the top flange of the exterior beams.

The beams or girders, supporting cantilever forming brackets, shall be tied together at 4 foot intervals.

For Standard construction, or Stage Construction the Hardwood bracing materials shall be placed as shown between webs of beams in each bay.

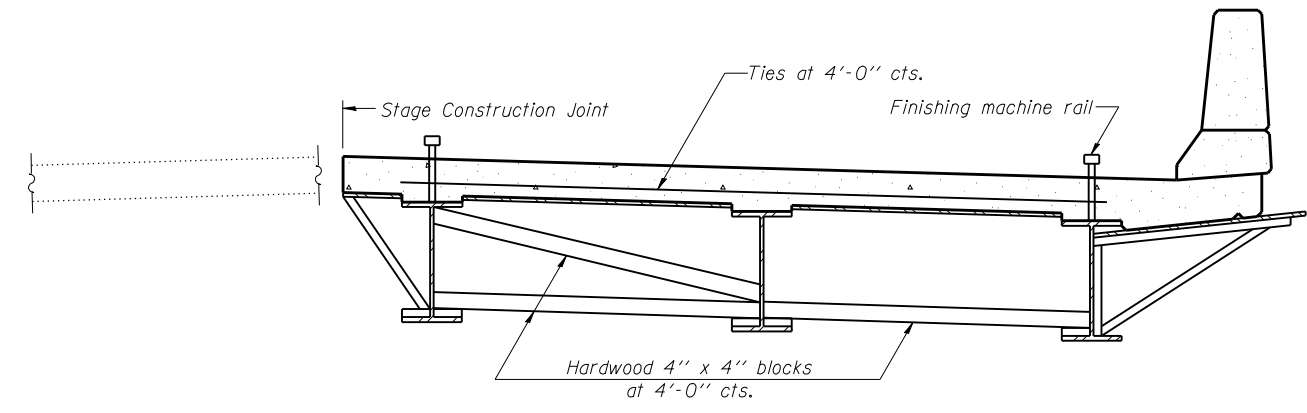

**FORM BRACES FOR
STAGE CONSTRUCTION**

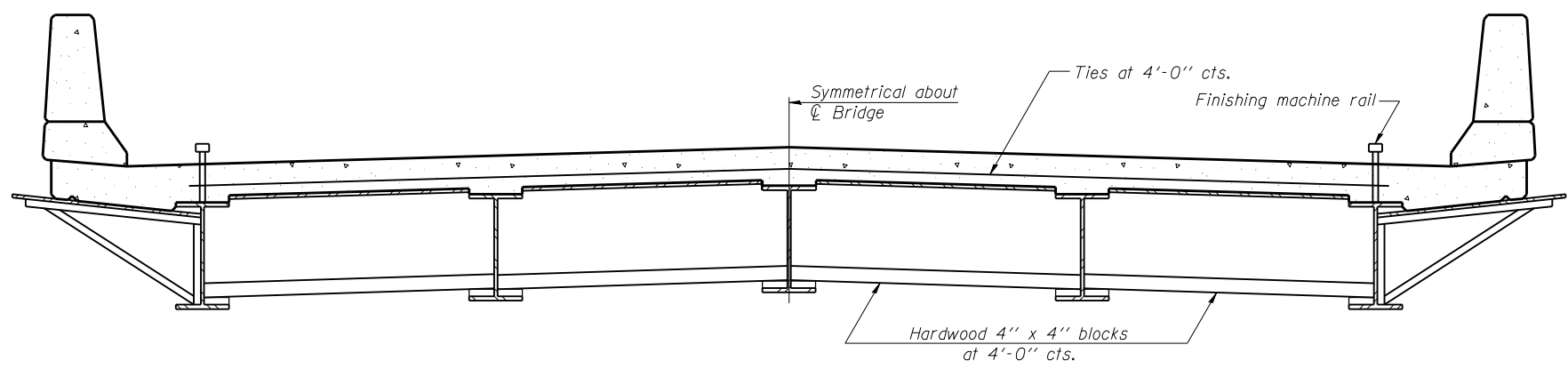

**FORM BRACES FOR
STANDARD CONSTRUCTION**

FILE NAME = 74217-021-1b-1.dgn
 PROJECT NO. 00853-5

SB-1 7-1-10

Coome-Bloxdorf P.C.
 - CIVIL ENGINEERS -
 - STRUCTURAL ENGINEERS -
 - LAND SURVEYORS -
 Design Firm License No. 184-002703

USER NAME = .CFC.	DESIGNED - GB/MCB	REVISED -
	CHECKED - MCB	REVISED -
PLOT SCALE = 0:2.000000 '1' / IN.	DRAWN - TFG	REVISED -
PLOT DATE = 7/23/2013	CHECKED - MCB	REVISED -

**STATE OF ILLINOIS
DEPARTMENT OF TRANSPORTATION**

**CANTILEVER FORMING BRACKETS FOR SUPERSTRUCTURES WITH
W27 BEAMS AND SMALLER STRUCTURE NO. NO. 093-0024**

F.A. RTE.	SECTION	COUNTY	TOTAL SHEETS	SHEET NO.
1B	(12A)B-1	WABASH	52	43
ILLINOIS FED. AID PROJECT			CONTRACT NO. 74217	