

A-A \*

\* DIMENSIONS OF THE CURB & GUTTER AT SECTION A-A ARE SHOWN ON STATE STANDARD 606001. FOR DETAILS OF OUTLET FOR CONCRETE CURB & GUTTER, TYPE B-6.24 (B-15.60) SEE STATE STANDARD 606006.

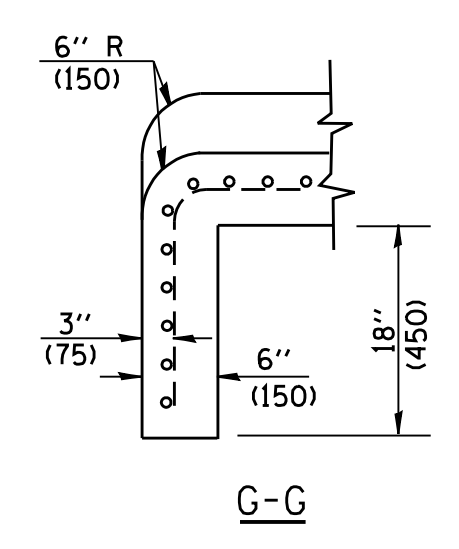
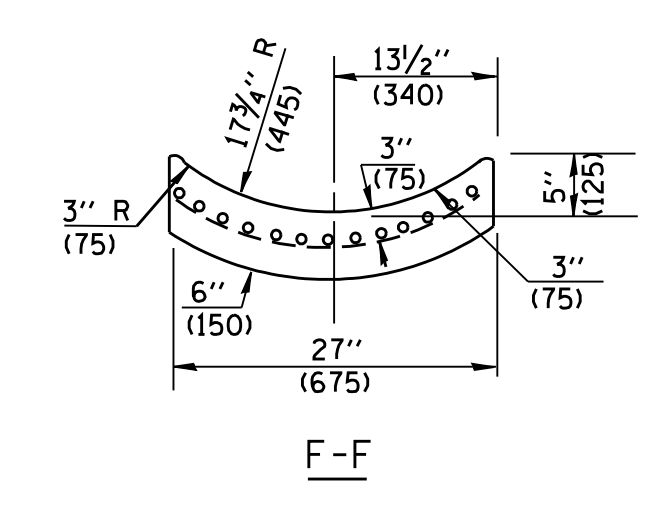
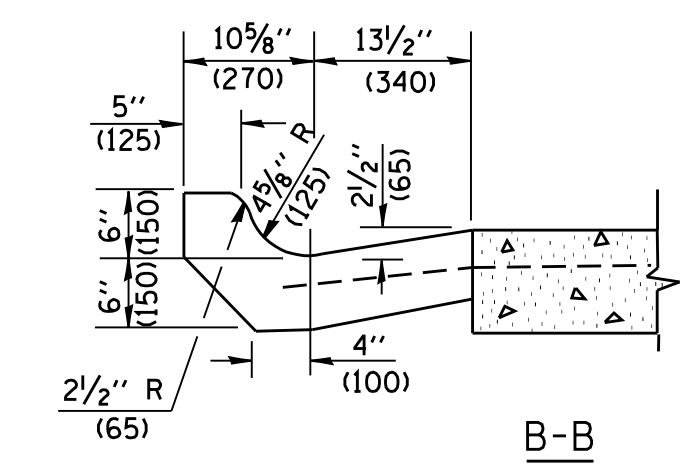
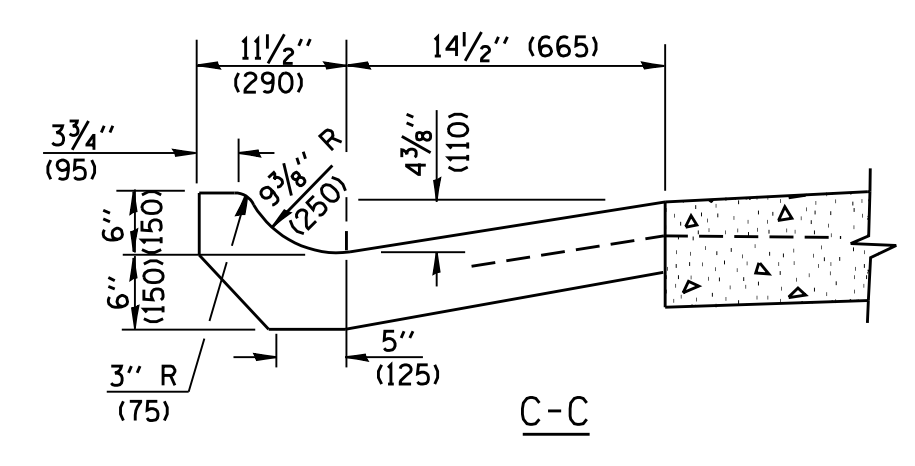
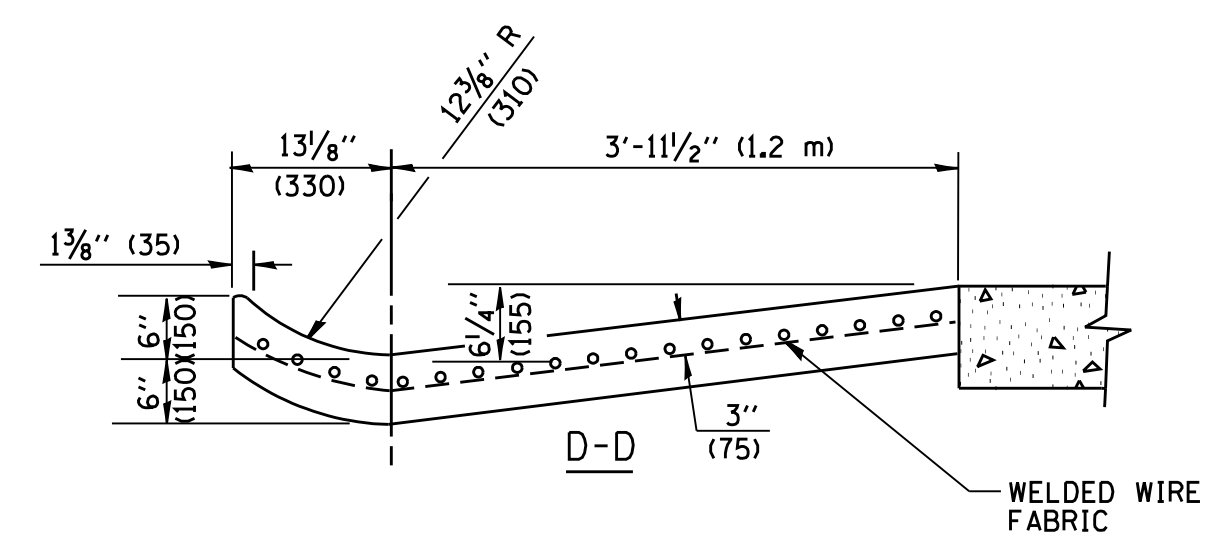
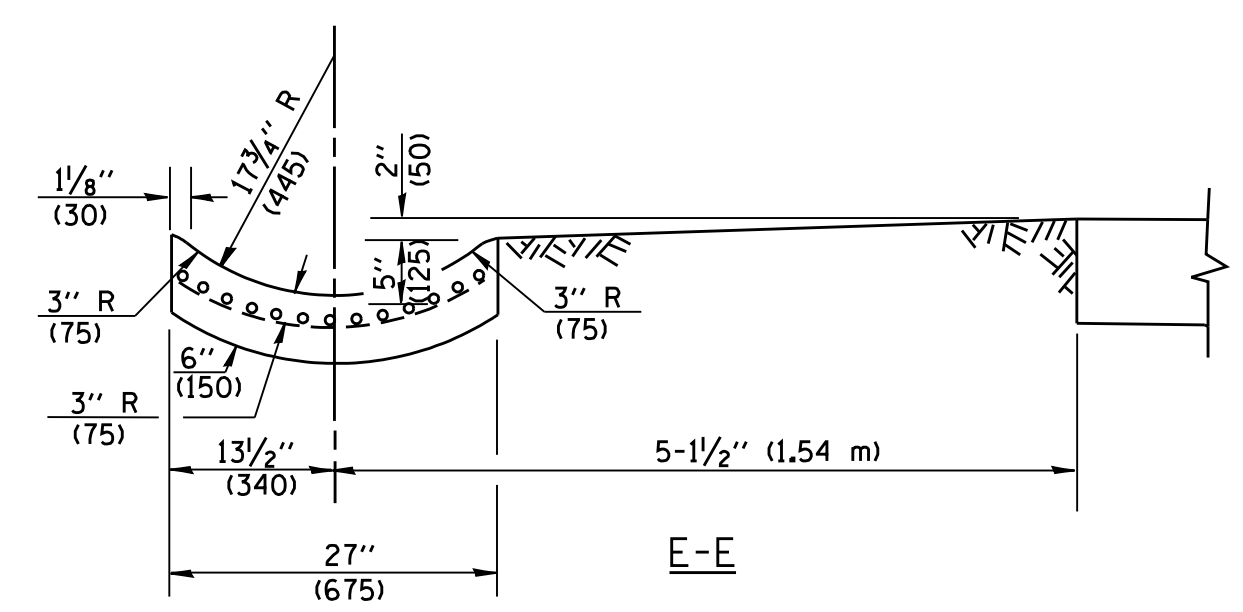

**GENERAL NOTES**

GUTTER OUTLET SHALL BE TIED TO THE PAVEMENT IN ACCORDANCE WITH DETAILS FOR LONGITUDINAL CONSTRUCTION JOINT SHOWN ON STANDARD 420001.

TIE BARS SHALL BE NO. 20 (NO.6) AT 24\"/>

IF THE AVERAGE GRADE OF PAVEMENT FOR THE DISTANCE FROM SECTION A-A TO D-D EXCEEDS 2%, THIS DISTANCE SHALL BE INCREASED 6' (1.8 m) FOR EACH 1% INCREASE IN GRADE.

**QUANTITIES**

FOR SECTION A-A TO E-E AND CURTAIN WALL =  
 1.25 CU. YDS. (0.96 m<sup>3</sup>) CLASS S1 CONCRETE (OUTLET) FOR 9\"/>

ALL DIMENSIONS ARE IN INCHES (MILLIMETERS) UNLESS OTHERWISE SHOWN.

FILE NAME = W:\diststd\22x34\bd03.dgn	USER NAME = gaglionobt	DESIGNED - M. DE YONG	REVISED - R. SHAH 09-09-94	<b>STATE OF ILLINOIS DEPARTMENT OF TRANSPORTATION</b>	<b>OUTLET FOR CONCRETE CURB AND GUTTER</b>			F.A. RTE.	SECTION	COUNTY	TOTAL SHEETS	SHEET NO.
	PLOT SCALE = 50.0000' / IN.	CHECKED -	REVISED - R. SHAH 10-25-94		SCALE: NONE	SHEET NO. 1 OF 1 SHEETS	STA.	TO STA.	BD600-01 (BD-03)	CONTRACT NO.		
PLOT DATE = 1/4/2008	DATE - 08-04-86		REVISED - E. GOMEZ 12-21-00					FED. ROAD DIST. NO. 1	ILLINOIS	FED. AID PROJECT		