

**PRIMARY TRANSVERSE,  
LONGITUDINAL CRACK &  
P.C.C. CENTERLINE JOINT**

**SECONDARY  
ADJACENT CRACK**

**NOTES**

- ① Route or saw to  $\frac{3}{4}(20)$  wide by  $\frac{3}{4}(20)$  deep; (1:1 ratio).
- ② Overfill with sealant; squeegee to provide 2 (50) wide flush "band-aid" effect; feather edges flush.
- ③ Seal flush without "band-aid" effect.
- ④ Route to 1(25) depth; clean and reface walls.
- ⑤ Route or saw  $\frac{3}{4}(20)$  wide by variable depth. Depth based upon crack or joint depth and  $\frac{3}{4}(20)$  minimum sealer over backer rod.

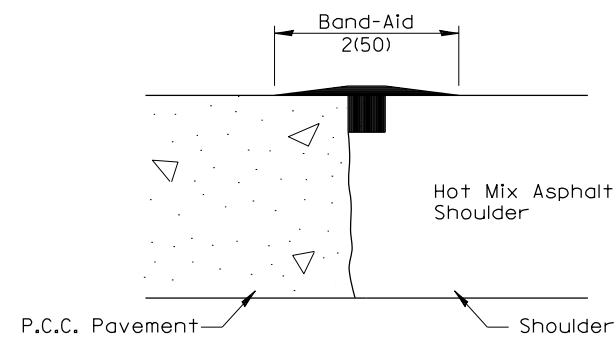

**SHOULDER JOINT (Notes ① & ②) AND  
LONGITUDINAL RANDOM CRACK (Notes ① & ③)**

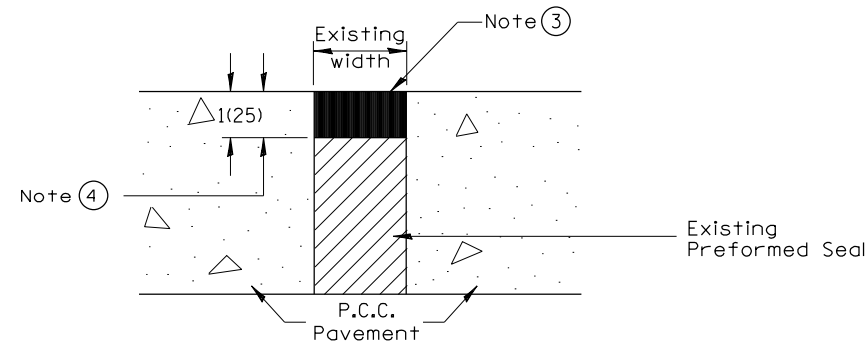

**TRANSVERSE EXPANSION JOINT**

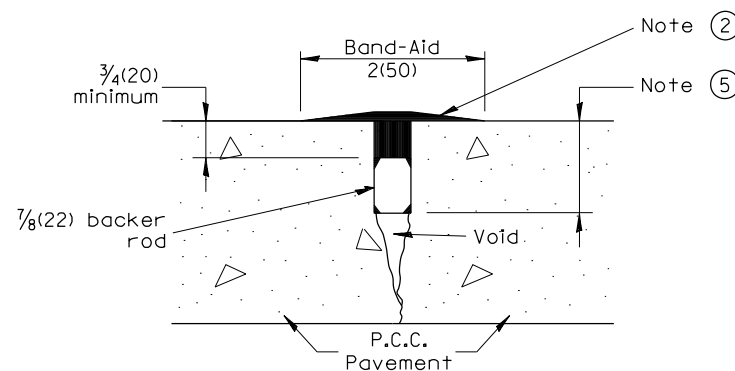

**SPECIAL TREATMENT - BACKER ROD**  
FOR JOINTS AND/OR CRACKS GREATER  
THAN  $\frac{3}{4}(20)$  DEEP  
(DOES NOT APPLY TO TRANSVERSE RANDOM CRACKS  
IN CONTINUOUSLY REINFORCED PAVEMENTS)

**GENERAL NOTES**

- 1. Crack and Joint Sealing shall conform to Section 451 and 452.
- 2. The "Band Aid" width shall be reduced or eliminated in areas adjacent to existing pavement markings.

All dimensions are in inches (millimeters) unless otherwise noted.

01-01-97	RENUM. C-36.01, NEW REVISE BOX	T.P.
05-01-97	REVISED	E.T.
10-16-06	REVISED TO 2007 SPEC.	M.A.

**STATE OF ILLINOIS  
DEPARTMENT OF TRANSPORTATION**

**CRACK AND JOINT SEALING**

NOT TO SCALE

CADD STD. 452001-D4

F.A. RTE.	SECTION	COUNTY	TOTAL SHEETS	SHEET NO.
CONTRACT NO.				
FED. ROAD DIST. NO. ILLINOIS FED. AID PROJECT				