

# NON-COMMERCIAL AND COMMERCIAL URBAN

(WITH 0' TO 2 1/2' (0 mm TO 760 mm) FROM BACK OF CURB TO SIDEWALK)

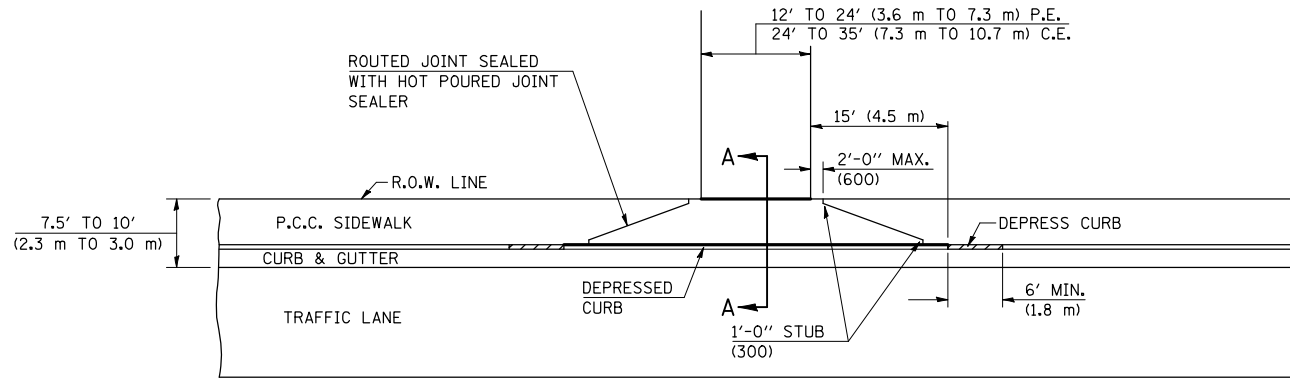

**PLAN WITHOUT BOULEVARD**

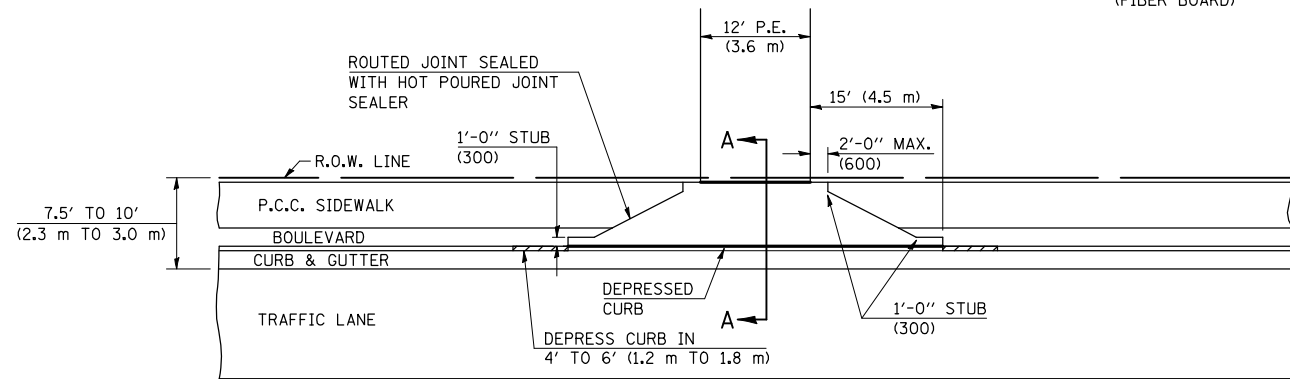

**PLAN WITH BOULEVARD**

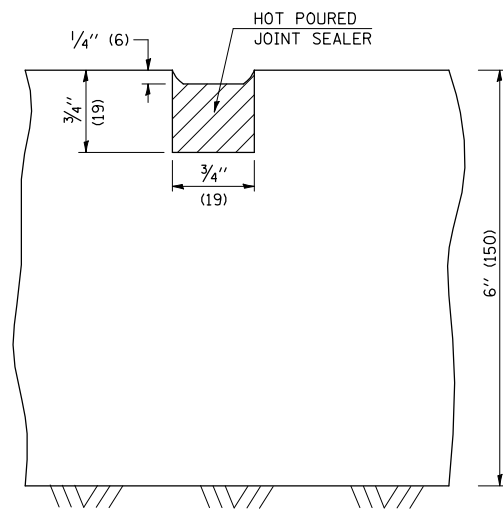

**DETAIL OF SAWED OR ROUTED JOINT**

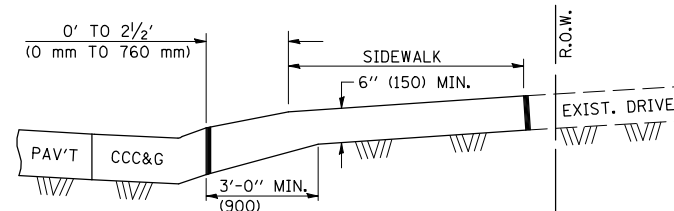

**SECTION A-A**

### GENERAL NOTES

THICKEN SIDEWALK TO 6" (150 mm) (MIN.) WITHIN LIMITS OF DEPRESSED CURB.

1. THIS LONGITUDINAL CURB EXPANSION JOINT SHALL BE PLACED ONLY WHERE THE PROPOSED P.C. CONCRETE SIDEWALK OR DRIVEWAY PAVEMENT MEETS AN EXISTING CONCRETE ENTRANCE.
2. THE LONGITUDINAL CURB EXPANSION JOINT SHALL CONFORM TO SECTION 1051 OF THE STANDARD SPECIFICATIONS.
3. THICKEN SIDEWALK FROM 5" TO 6" (127 mm TO 150 mm) WITHIN DRIVEWAY LIMITS OF DRIVEWAY.

10' TO 15' (3 m TO 4.6 m) FROM TRAVELLED LANE TO RIGHT OF WAY

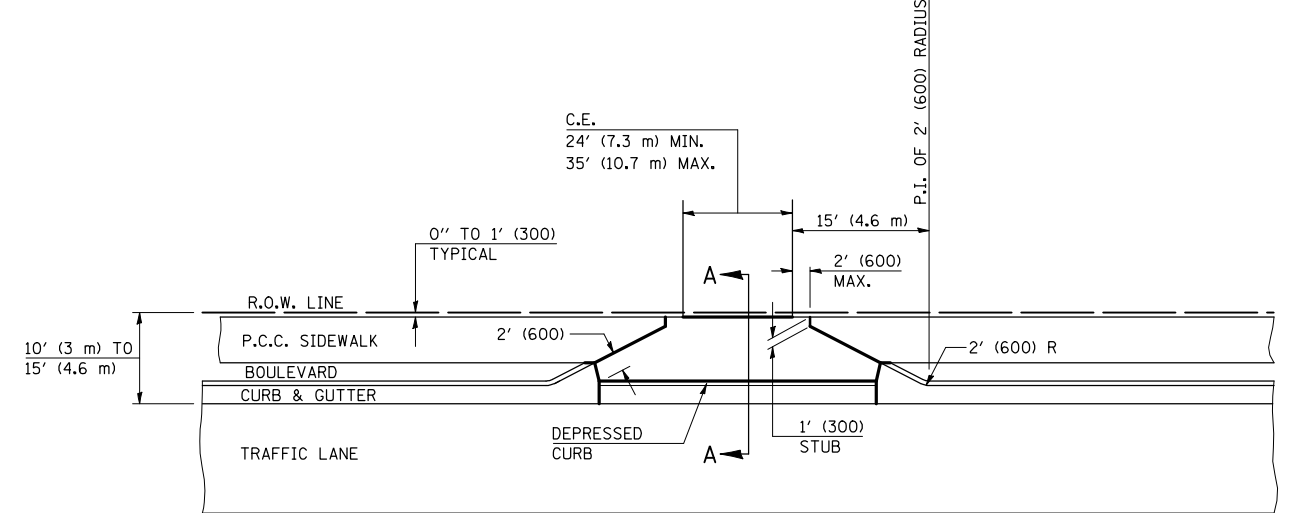

PREFORMED EXPANSION JOINT (FIBER BOARD)

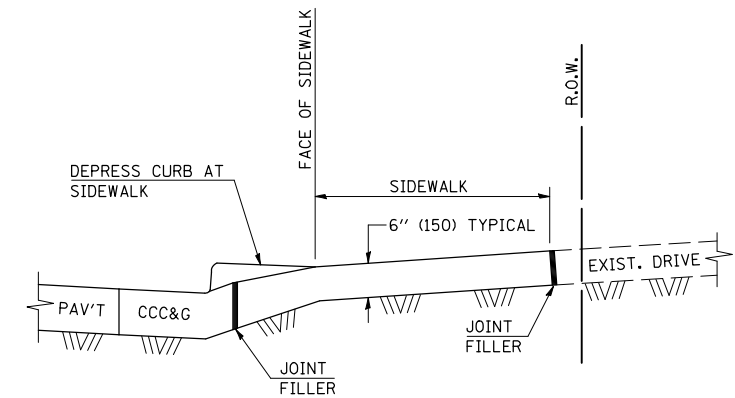

**SECTION A-A WITH SIDEWALK**

NOTE: WHEN EXISTING SIDEWALK IS TO REMAIN IN PLACE, THE JOINT FILLER IS TO BE PLACED AT THE FACE OF SIDEWALK.

NOTE: THICKEN SIDEWALK FROM 5" (125) TO 6" (150) WITHIN LIMITS OF DRIVEWAY FLARE [15' (4.6 m) EITHER SIDE OF DRIVEWAY].

Note: All dimensions are in INCHES (millimeters) unless otherwise shown.

### DISTRICT 5 DETAIL NO. 42300BBB

FILE NAME =	USER NAME = craigre	DESIGNED -	REVISED - 11/06
et\p\work\PWIDOT\CRAIGRE\0101509\42300bbb.dgn		DRAWN -	REVISED -
PLOT SCALE = 40.000' / IN.		CHECKED -	REVISED -
PLOT DATE = 1/7/2010		DATE -	REVISED -

**STATE OF ILLINOIS  
DEPARTMENT OF TRANSPORTATION**

### ENTRANCES WITH NARROW R.O.W.

SCALE: SHEET NO. OF SHEETS STA. TO STA.

F.A. RTE.	SECTION	COUNTY	TOTAL SHEETS	SHEET NO.
CONTRACT NO.				
FED. ROAD DIST. NO. ILLINOIS FED. AID PROJECT				

FOR C.E. WITH DISTANCE FROM EDGE OF TRAVELLED LANE BETWEEN 15' (4.6 m) AND 17' (5.2 m) USE 15' (4.6 m) OR 20' (6.1 m) RADIUS AND TRUNCATE AT BACK OF SIDEWALK.

FOR P.E. WITH DISTANCE FROM EDGE OF TRAVEL LANE TO R.O.W. BETWEEN 10' (3.0 m) TO 5.2 m) USE 15' (4.6 m) RADIUS AND TRUNCATE AT BACK OF SIDEWALK.

SEE PLAN PREPARATION MEMORANDUM 40-09