

GUTTER DEPRESSION 1" (25mm)

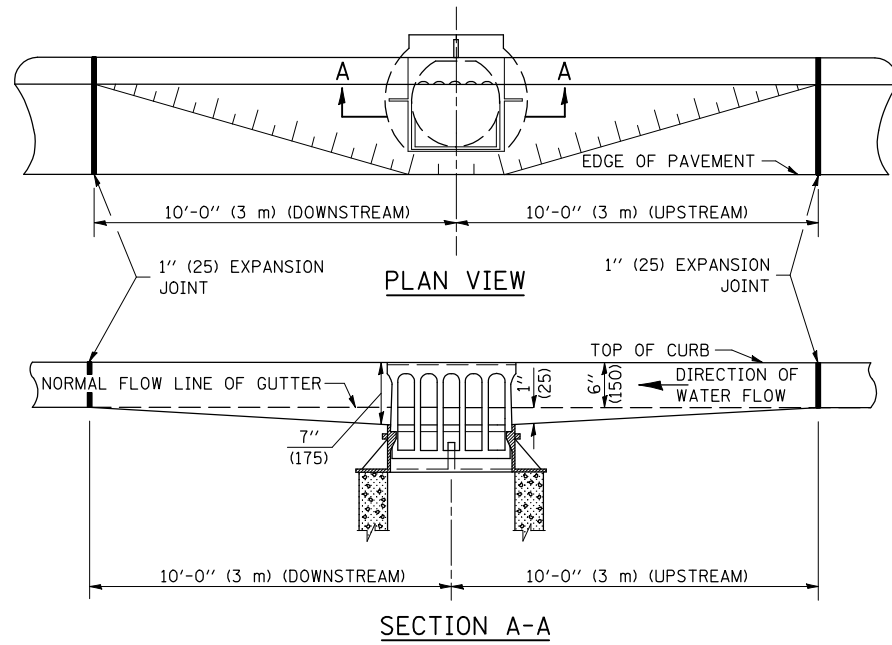

GUTTER DEPRESSION 0.1 FOOT (30mm)

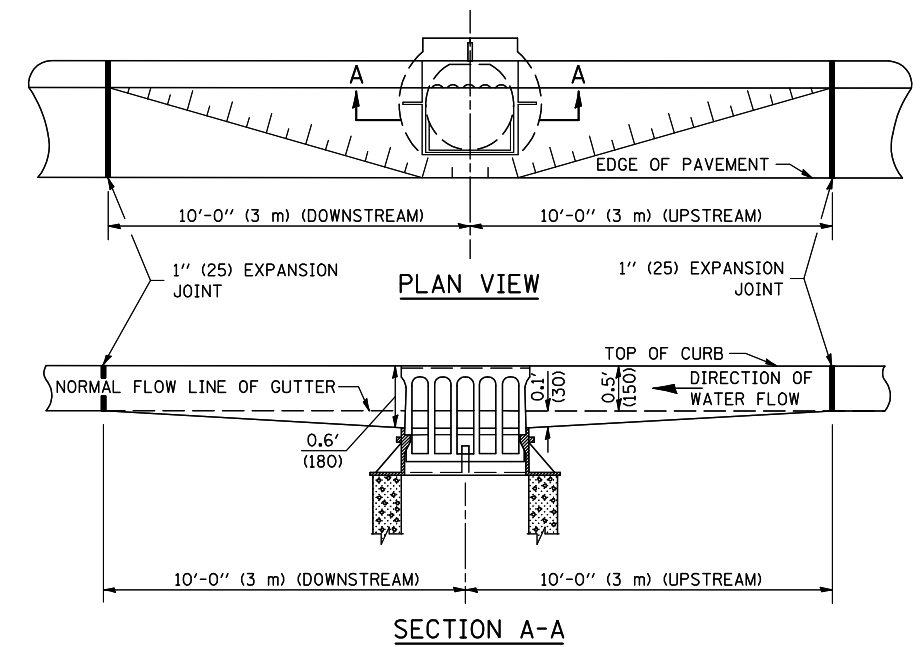

GUTTER DEPRESSION 2" (50mm)

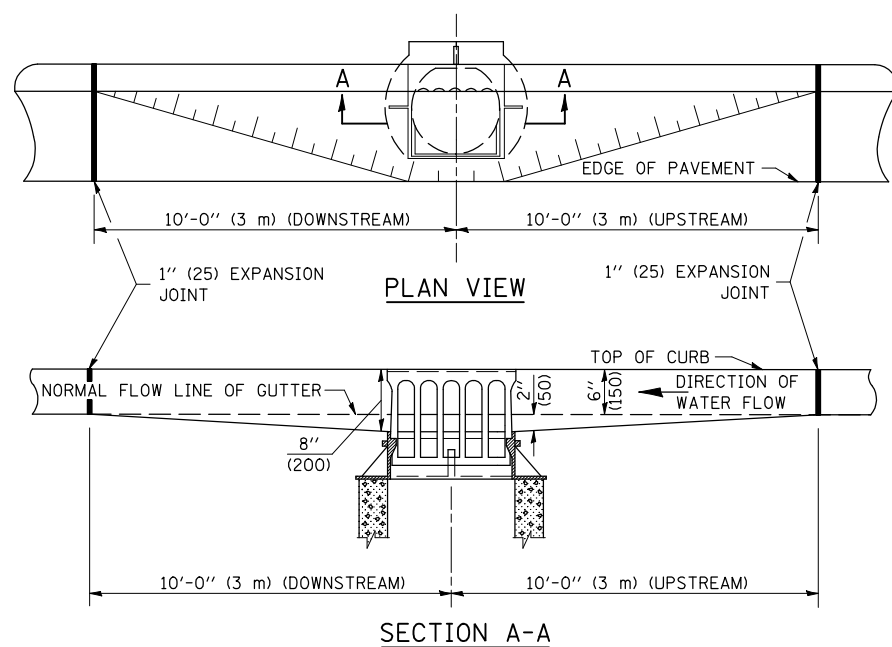

GUTTER DEPRESSION 0.2 FOOT (60mm)

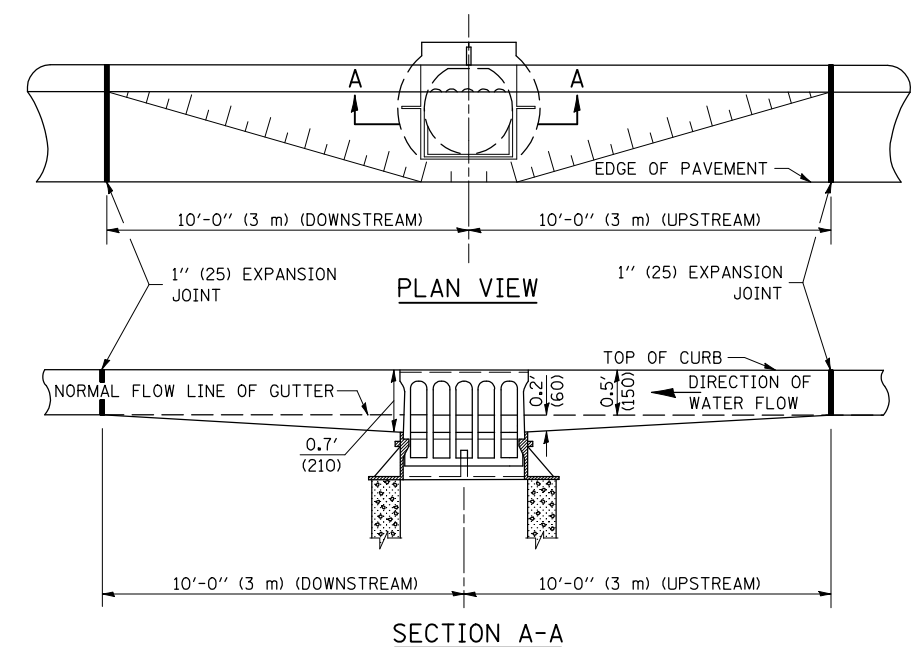

GENERAL NOTES

1. THE TWO EXPANSION JOINTS SHALL BE PLACED AS SHOWN IN STANDARD 606001.
2. THE GUTTER GRADE SHALL BE DEPRESSED AT ALL INLETS, CATCH BASINS AND MANHOLES UNLESS OTHERWISE SPECIFIED IN THE PLANS.
3. THE COST OF THIS WORK SHALL BE INCLUDED IN THE COST OF THE VARIOUS PAY ITEMS OF WORK INVOLVED.

Note: All dimensions are in INCHES (millimeters) unless otherwise shown.

DISTRICT 5 DETAIL NO. 606AAAAA

FILE NAME =	USER NAME = craigre	DESIGNED -	REVISED - 11/06
ct:\pw\work\PWIDOT\CRAIGRE\0101509\606000.dgn		DRAWN -	REVISED -
	PLOT SCALE = 40.000' / IN.	CHECKED -	REVISED -
	PLOT DATE = 1/7/2010	DATE -	REVISED -

**STATE OF ILLINOIS
DEPARTMENT OF TRANSPORTATION**

GUTTER DEPRESSION AT INLETS, CATCH BASINS AND MANHOLES

SCALE: SHEET NO. OF SHEETS STA. TO STA.

F.A. RTE.	SECTION	COUNTY	TOTAL SHEETS	SHEET NO.
CONTRACT NO.				
FED. ROAD DIST. NO. ILLINOIS FED. AID PROJECT				