

TYPE "A3" BICYCLE RACK ELEVATION

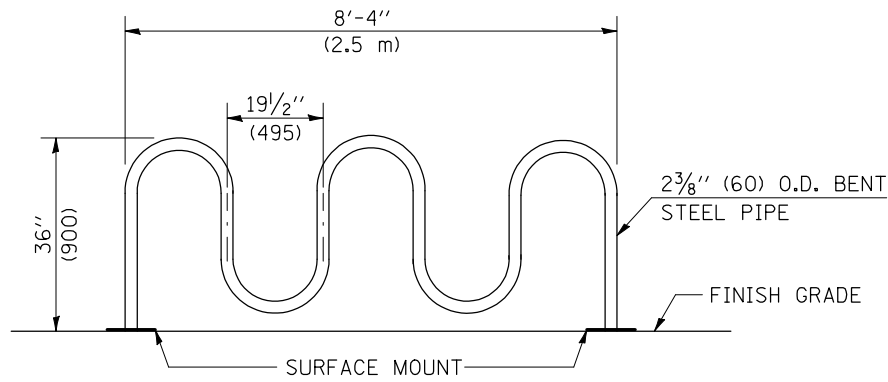

TYPE "A5" BICYCLE RACK ELEVATION

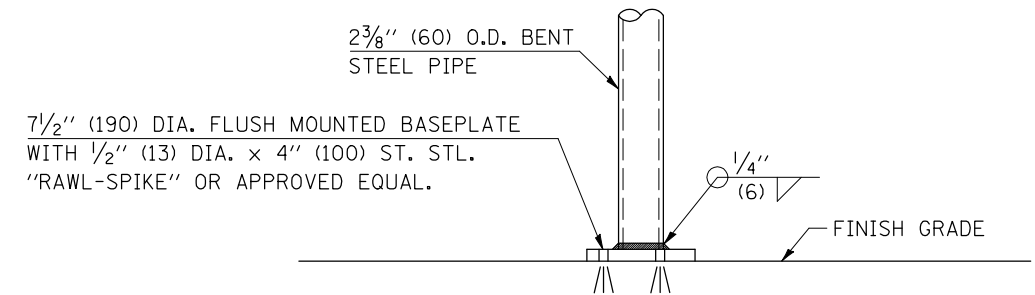
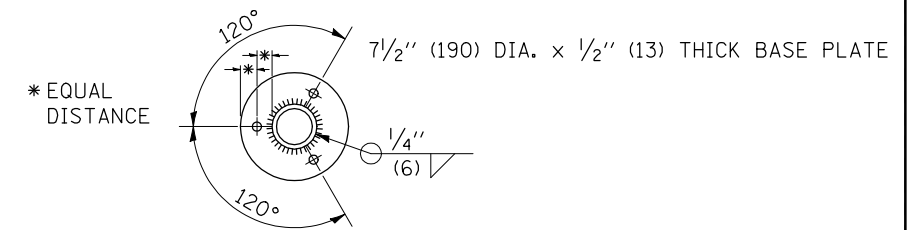

SURFACE MOUNT DETAIL

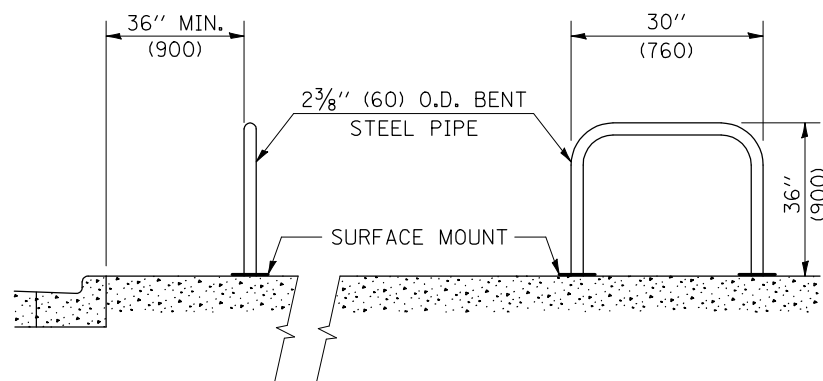

TYPE "B" BICYCLE RACK ELEVATION

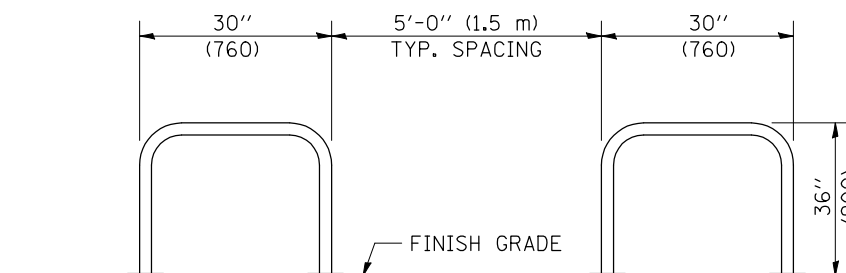

Note: All dimensions are in INCHES (millimeters) unless otherwise shown.

DISTRICT 5 DETAIL NO. XX001011

FILE NAME =	USER NAME = craigre	DESIGNED -	REVISED - 12/06
et\p\work\PWIDOT\CRAIGRE\d0101509\xx001011.dgn		DRAWN -	REVISED -
	PLOT SCALE = 40.0000 ' / IN.	CHECKED -	REVISED -
	PLOT DATE = 1/7/2010	DATE -	REVISED -

**STATE OF ILLINOIS
DEPARTMENT OF TRANSPORTATION**

BICYCLE RACKS

SCALE: SHEET NO. OF SHEETS STA. TO STA.

F.A. RTE.	SECTION	COUNTY	TOTAL SHEETS	SHEET NO.
CONTRACT NO.				
FED. ROAD DIST. NO. ILLINOIS FED. AID PROJECT				