

STATE OF ILLINOIS  
DEPARTMENT OF PUBLIC WORKS AND BUILDINGS  
BUREAU OF DESIGN

CONSTRUCTION PLAN INDEX

REEL 0-65

ROUTE	SECTION	COUNTY	NO. OF EXP.	REMARKS
CH-130 SBI-63	3035-15B-2-Y-2B	COOK	65	
SBI-1 (FA-1)	3268-15B-2-W-1	COOK	41	
	BUILDING REMOVAL			
FA-131	Master Plan For Building Removal	COOK	12	
SBI-46 (FA-45)	464-Y-I-V Building Removal	COOK	6	
CH (SA) 128	3072-A-15B-2-Y-V	COOK	6	
SBI-46	462-D-3	COOK	15	
SBI-53 FA-61	531-2-1	COOK	105	
FAI-90	3334-250 80	COOK	8	
Dist. 10	10X-FR-1964-2	COOK	13	
FAI-59	0507-635-TB	COOK	14	
FAI-90	3334-250 TB	COOK	16	
Dist. 10	Pavement Marking 1958-1	COOK	7	
SA-263	263-21012 A MPT	COOK	15	
SBI-46 FA-45	Intersection Improvement 464-Y-I	COOK	39	
SBI-53 FA-61	531-2-VNB	COOK	69	
FA-42 CHS-33	1964-17 2B Bit. Resurfacing	COOK	11	
FA-6 UB-20	(S R-1) I	COOK	7	

STATE OF ILLINOIS  
DEPARTMENT OF PUBLIC WORKS AND BUILDINGS  
BUREAU OF DESIGN

CONSTRUCTION PLAN INDEX

REEL 0-65

ROUTE	SECTION	COUNTY	NO. OF EXP.	REMARKS
FAI-94	BR-1964-1E Bridge Repair	COOK	12	
SBI-4 FA-98	430-B-W	COOK	23	
E.O.R.M.	1963-1	COOK	11	
SBI-19	70-R-I	COOK	9	
SBI-22	728-28	COOK	14	
P.E.R.	1963-1	COOK	9	
FAI-90 FAI-94 FAI-90	(2424) 1958-1 (0116) (0307 & 2426)	COOK	10	
SBI-60 FA-60	Z NY-Ext. & Z R-1-T	COOK	37	
	Total		369	

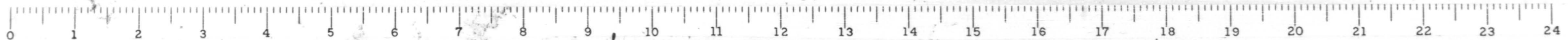

RT. SBI-53  
FA-61

SEC. 531-2-VHB

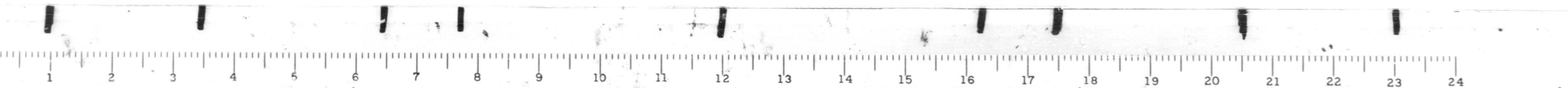



**STATE OF ILLINOIS**  
**DEPARTMENT OF PUBLIC WORKS AND BUILDINGS**  
**DIVISION OF HIGHWAYS**  
**PLANS FOR PROPOSED**  
**FEDERAL AID HIGHWAY**

FEDERAL AID ROUTE NO.	SEC.	COUNTY	TOTAL SHEETS	SHEET NO.
S.B.I. 53	531-2	COOK	67	1
F.A. 61	-VHB			

JOB NO. P-90-003-00

INDEX OF SHEETS ON SHEET NO. 2

(S.B.I. ROUTE 53) F.A. ROUTE 61 SECTION 531-2-VHB-COOK COUNTY  
 PROJECT U-UG 184 (36)

C-90-412-64

RELOCATED ROUTE 53

DUAL STRUCTURES OVER NORTHWEST HIGHWAY & C. & N. W. R.R.

PROJECT LENGTH 516.58 LIN. FT. OR 0.098 MILES

PROJECT U-UG-184(36)  
 ENDS STA. 272 + 18.03

SECTION 531-2-VHB INCLUDES THE CONSTRUCTION OF DUAL 7-SPAN CONTINUOUS WIDE FLANGE BEAM GRADE SEPARATION STRUCTURES (TO CARRY RELOCATED ROUTE 53 OVER NORTHWEST HIGHWAY AND THE C. & N.W. R.R.) WITH SPANS AT 64'-5 1/2", 82'-6", 65'-2 1/2", 79'-8", 77'-2", 82'-10" AND 61'-5", ON OPEN R.C. ABUTMENTS AND R.C. PIERS, AT STATION 270 + 71.17 IN PALATINE TOWNSHIP;

PROJECT U-UG 184(36)  
 BEGINS STA. 267 + 01.45

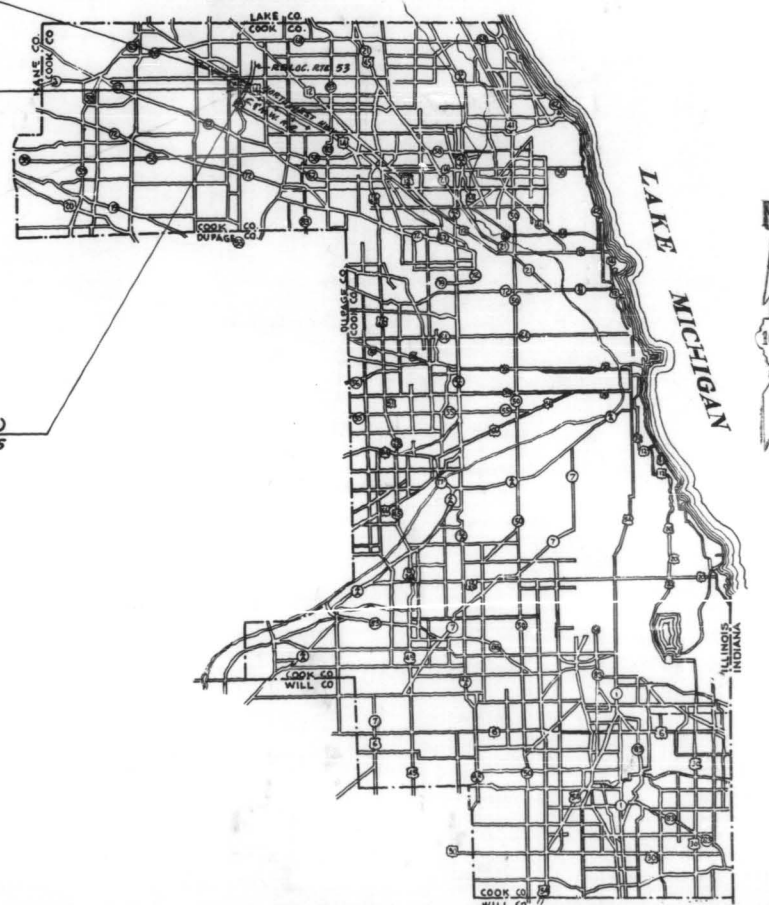

LOCATION OF SECTION INDICATED THIS:—

STATE OF ILLINOIS  
 DEPARTMENT OF PUBLIC WORKS AND BUILDINGS  
 DIVISION OF HIGHWAYS

SUBMITTED July 17 1964  
*C.A. Penowen* DISTRICT ENGINEER

EXAMINED July 27 1964  
*William R. Dandell* DISTRICT ENGINEER

PASSED July 27 1964  
*John J. ...* DISTRICT ENGINEER

APPROVED July 27 1964  
*[Signature]* DISTRICT ENGINEER

APPROVED July 27 1964  
*[Signature]* DISTRICT ENGINEER

DEPARTMENT OF COMMERCE  
 BUREAU OF PUBLIC ROADS

APPROVED \_\_\_\_\_

DIVISION ENGINEER DATE

CONTRACT NO. 23778

COUNTY COOK SECTION 531-2-VHB F. A. ROUTE 61

F. KENNEDY

PLANS PREPARED BY BUREAU OF DESIGN  
 APPROVED BY ASS'T DISTRICT ENGINEER-ENGINEERING  
 EXAMINED BY BUREAU OF CONSTRUCTION  
 EXAMINED BY BUREAU OF MAINTENANCE  
 EXAMINED BY BUREAU OF TRAFFIC  
 EXAMINED BY BUREAU OF MATERIALS  
 ENTIRE SECTION INSPECTED AND APPROVED  
 AS TO POLICY DISTRICT ENGINEER

*Albert Sipes* DATE 7-16-64  
*Arthur C. Williams* DATE 7-17-64  
*Frank W. Thompson* DATE 7-16-64  
*August J. Smith* DATE 7-16-64  
*Charles P. McLean* DATE 7-16-64  
*Ed. J. Smith* DATE 7-16-64  
*C.A. Benouin* DATE 7-17-64

ROAD DISTRICT	SECTION	COUNTY	TOTAL SHEETS	SHEET NO.
581-99	581-2-VH	COOK	67	2
PA-61				
STA.	TO STA.			
U.S. BUREAU OF PUBLIC ROADS, DIV. 6   ILLINOIS PROJECT				

### SUMMARY OF QUANTITIES

PAY ITEM	UNIT	TOTAL QUANTITY	CODE NO.
POROUS GRANULAR EMBANKMENT	CU YD	250	019001
CONCRETE REMOVAL	CU YD	19	049003
EXPANSION BOLTS, 3/4 INCH	EACH	24	049005
CLASS A EXCAVATION FOR STRUCTURES	CU YD	1,490	050001
CLASS X CONCRETE	CU YD	4,572.5	052003
PROTECTIVE COAT	SQ YD	7,786	052021
FURNISHING AND ERECTING STRUCTURAL STEEL	POUND	1,993,140	054001
REINFORCEMENT BARS	POUND	906,700	059001
FURNISHING CREDOSOTED PILES, 20.1 TO 38 FEET	LIN FT	19,392	060005
FURNISHING CREDOSOTED PILES, OVER 38 FEET	LIN FT	1,800	060006
TEST PILES, TIMBER	EACH	2	060007
DRIVING TIMBER PILES	EACH	21,192	060008
FURNISHING PRECAST CONCRETE PILES, 14"	LIN FT	4,634	060010
TEST PILES, PRECAST CONCRETE	EACH	1	060012
DRIVING PRECAST CONCRETE PILES	LIN FT	4,634	060013
DRIVING CONCRETE PILES	LIN FT	3,555	060043
FURNISHING CONCRETE PILES	LIN FT	3,555	060044
TEST PILES, CONCRETE	EACH	3	060047
TEMPORARY SHEETING	SQ FT	9,841	060051
NAME PLATES	EACH	2	061001
PAVEMENT REMOVAL	SQ YD	140	082001
SLOPE WALL, 4 INCH	SQ YD	2,910	083002
ALUMINUM HANDRAIL	LIN FT	2,052	200004
RAILROAD PROTECTIVE SERVICES	L SUM	1	201065

### INDEX OF SHEETS

SHEET NO.	DESCRIPTION
1.	COVER SHEET
2.	INDEX OF SHEETS, SUMMARY OF QUANTITIES, SIGNATURES
3.	EXISTING TOPOGRAPHY & PLAN OF PROPOSED IMPROVEMENT
4.	PROFILES & ROADWAY SECTIONS
5.	DETAIL OF EXISTING STONE ARCH CULVERT
6.	GENERAL PLAN & ELEVATION OF STRUCTURES
7.	BILL OF MATERIAL, GENERAL NOTES & SHEET INDEX FOR STRUCTURES
8.	SLOPE WALL DETAILS
9 - 11.	BORING DATA
12 - 17.	SUPERSTRUCTURE DETAILS - UNIT "B"
18 - 23.	SUPERSTRUCTURE DETAILS - UNIT "E"
24 - 29.	SUPERSTRUCTURE DETAILS - UNIT "C"
30 - 35.	SUPERSTRUCTURE DETAILS - UNIT "F"
36 - 41A.	EXPANSION DEVICE DETAILS & HANDRAIL
42.	RAIL & LIGHT STANDARD DETAILS
43 - 46.	RAIL & PARAPET DETAILS
47 - 50.	ABUTMENT DETAILS
51 - 63.	PIER DETAILS
64.	TEMPORARY SHEETING DETAILS
65.	PILE DETAILS
66.	STANDARD 1686-2 (SYMBOLS); STANDARD 2113-1 (NAME PLATE)
67.	STANDARD 1971-3 ("ROAD UNDER CONSTRUCTION" SIGN); STANDARD 2114 (FLAGMAN SIGN); STANDARD 2158-2 (FEDERAL AID PRIMARY SIGN)

NOTE: SEE SHEET 7 FOR DETAILED INDEX OF STRUCTURE PLAN SHEETS (SHEETS 6 TO 65).

TWO (2) SIGNS CONFORMING TO STANDARD 2158-2 SHALL BE ERECTED AT LOCATIONS SHOWN ON SHEET 3 OR AS DIRECTED BY THE ENGINEER.

NOTE: THE "STANDARD SPECIFICATIONS FOR ROAD & BRIDGE CONSTRUCTION" ADOPTED JANUARY 2, 1958 AND THE SUPPLEMENTAL SPECIFICATIONS EFFECTIVE MARCH 2, 1964, SHALL GOVERN THE CONSTRUCTION OF THIS WORK

AXLE LOAD LIMITS: **DHV-20 - CLASSIFICATION - DESIGN SPEED**  
 SINGLE - 18,000 LBS  
 TANDEM - 24,000 LBS  
 6425 M 70

REV. 7-22-64 CHANGED CODE FROM 3425 L.F. TO 3335 L.F. TO AGREE W/ PLAN SHEETS 1-1E  
 SELECTED PAY ITEM "CONSTRUCTION IDENTIFICATION SIGNS" 1 EACH --JE



B.M. "a" Cut in center of South Headwall for Salt Creek under Northwest Hwy, Elev. 714.49.

STATE OF ILLINOIS  
DEPARTMENT OF PUBLIC WORKS & BUILDINGS  
DIVISION OF HIGHWAYS

ROUTE NO.	SECTION	COUNTY	TOTAL SHEETS	SHEET NO.	SHEET NO. / GO SHEETS
53	531-2-VHB	COOK	67	6	
FED. ROAD DIST. NO. 7		ILLINOIS	FED. AID PROJECT: U-UG-184(36)		

S.B.I. RT. 53 - HORIZ. CURVE DATA

$\Delta = 77^{\circ} 11' 38''$   
 $D = 0^{\circ} 57' 17.8''$   
 $R = 6000'$   
 $T = 4789.21'$   
 $L = 6083.72'$   
 $E = 1677.02'$   
 $PC = Sta. 185 + 48.07$   
 $PT = Sta. 236 + 37.28$   
 $PI = Sta. 269 + 31.79$   
 $S.E. = 0.02\%$   
 Transition from Full Superelevation to Normal Crown Sta. 268 + 31.79 to Sta. 270 + 31.79.

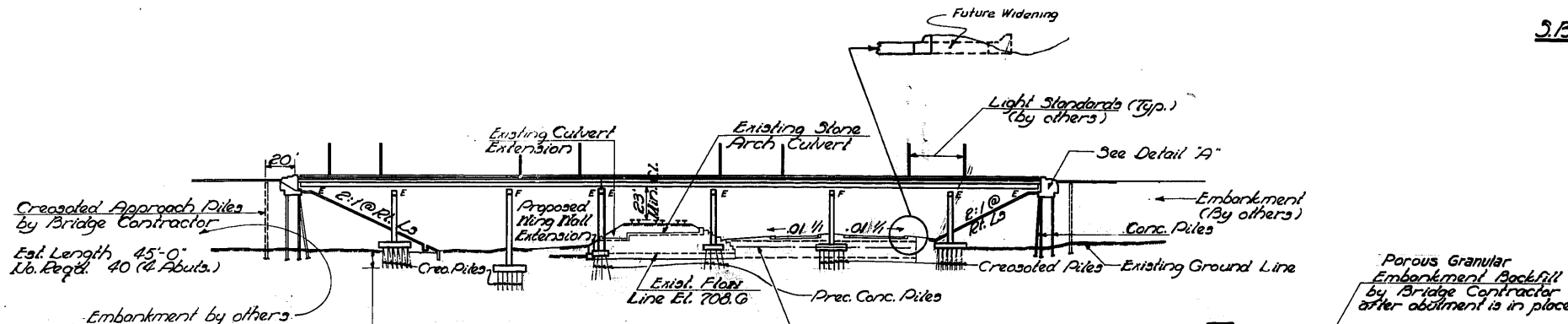

Note: ±G.O. of unsuitable material to be removed and replaced with embankment by others prior to placement of embankment cone

CURVE DATA - RAMP 'B'

$\Delta = 6^{\circ} 58' 32''$   
 $R = 6072.19'$   
 $L = 739.31'$   
 $T = 370.10'$   
 $E = 11.27'$

DETAIL 'A'

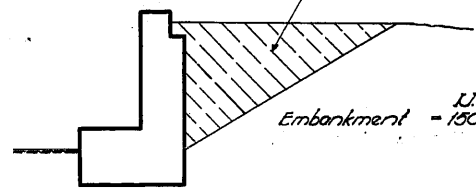

S.B.I. RT. 53 - VERTICAL CURVE DATA

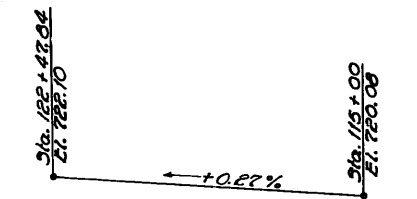

PROFILE - NORTHWEST HWY

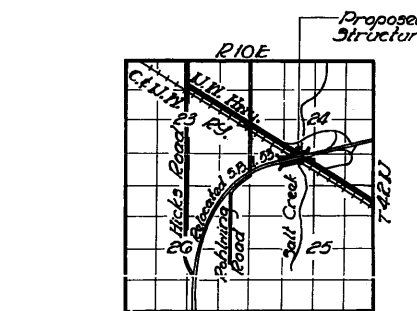

LOCATION PLAN

Angle btwn. curve tangents =  $0^{\circ} 49' 48''$   
 Reference Tangent Pt. = Sta. 269 + 31.79  
 Ramp 'B' PC: 50' Lt. Sta. 261 + 99.30

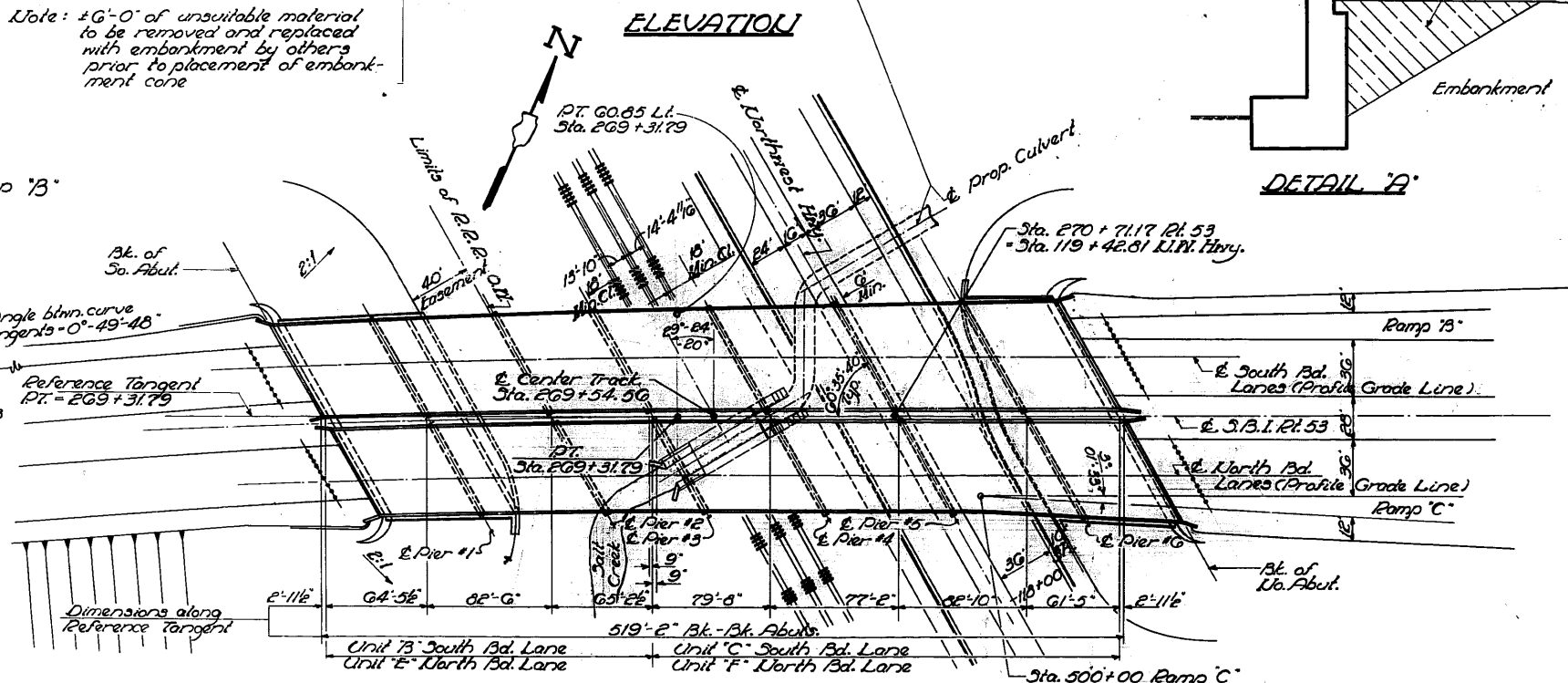

PLAN

Note: For slopefill & embankment details See Sheet #3.  
 Flow in Salt Creek shall be diverted by Contractor for Sec. 531-21 before construction begins. All excavation shall be classified as Class A Excavation for Structures.

STATIONS & ELEVATIONS

SOUTHBOUND LANES			
Location	Station	Grade Elev.	Btm. Ftg. Elev.
Bk. So. Abut.	266 + 61.92	755.83	747.04
E. Pier 1	267 + 47.61	756.22	714.96
E. Pier 2	268 + 23.52	756.55	704.79
E. Pier 3	268 + 92.89	756.69	707.71
E. Pier 4	269 + 72.24	756.72	710.00
E. Pier 5	270 + 49.41	756.61	714.38
E. Pier 6	271 + 32.24	756.31	714.62
Bk. No. Abut.	271 + 96.61	755.97	747.00

NORTHBOUND LANES			
Location	Station	Grade Elev.	Btm. Ftg. Elev.
Bk. So. Abut.	267 + 20.98	756.07	747.53
E. Pier 1	267 + 62.74	756.40	714.69
E. Pier 2	268 + 69.99	756.65	699.37
E. Pier 3	269 + 35.41	756.73	708.01
E. Pier 4	270 + 15.08	756.68	710.20
E. Pier 5	270 + 92.25	756.48	713.93
E. Pier 6	271 + 25.08	756.10	714.54
Bk. No. Abut.	272 + 39.45	755.68	746.79

C. & U.P. RY.  
 BUILT 1964 BY  
 STATE OF ILLINOIS  
 S.B.I. RT. 53 - SEC. 531-2-VHB  
 FA/PROJ. U-UG-184(36) STA. 270 + 71  
 LOADING H20

NAME PLATE  
 For Lettering See Std. 2113-1

DESIGN STRESSES  
 $f_c = 1400$  p.s.i. Super. & Sub.  
 $f_s = 20000$  p.s.i. Reinfr.  
 $f_s = 20000$  p.s.i. Struct. (A-36)  
 $V_c = 75$  p.s.i. Ftgs.  
 $n = 10$   
 Allowable 4 Deflection =  $L/1000$   
 LOADING H20-44

PROJ. U-UG-184(36)  
 GENERAL PLAN & ELEVATION  
 S.B.I. ROUTE 53 OVER  
 NORTHWEST HWY & C. & U.P. RY.  
 S.B.I. RT. 53 SEC. 531-2-VHB  
 COOK COUNTY  
 STA. 270 + 71.17

DESIGNED: James Harving  
 CHECKED: J. A. Nelson  
 DRAWN: Jacobs  
 EXAMINED: W. B. Blummann  
 PASSED: [Signature]  
 APPROVED: [Signature]  
 JUN 16 1964

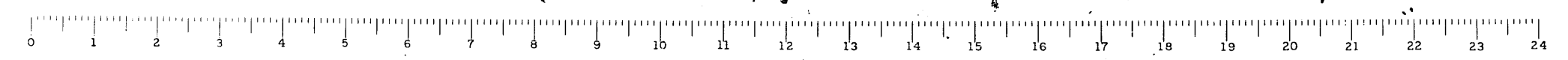



STATE OF ILLINOIS  
DEPARTMENT OF PUBLIC WORKS & BUILDINGS  
DIVISION OF HIGHWAYS

ROUTE NO.	SECTION	COUNTY	TOTAL SHEETS	SHEET NO.	SHEET NO. 2 60 SHEETS
S.B.I. 531-2-VHB	67	COOK	67	7	
P.A. 67	2-VHB				
FED. ROAD DIST. NO. 7	ILLINOIS	FED. AID PROJECT			

SHEET INDEX

6	GENERAL PLAN & ELEVATION	36	EXPAN. DEVICE-SO. ABUT-UNIT B
7	TOTAL BILL OF MATERIAL, GEN. NOTES	37	EXPAN. DEVICE-SO. ABUT-UNIT E
8	SLOPEWALL DETAILS	38	EXPAN. DEVICE-PIER 3-UNIT B & C
9	BORINGS	39	EXPAN. DEVICE-PIER 3-UNIT E & F
10	BORINGS	40	EXPAN. DEVICE-NO. ABUT. UNIT C
11	BORINGS	41	EXPAN. DEVICE-NO. ABUT. UNIT F
12	SUPERSTRUCTURE	42	RAIL & LIGHT STANDARD DETAILS
13	SUPERSTRUCTURE	43	RAIL & PARAPET-UNIT B
14	SLAB ELEVATIONS	44	RAIL & PARAPET-UNIT E
15	SLAB ELEVATIONS	45	RAIL & PARAPET-UNIT C
16	STRUCTURAL STEEL	46	RAIL & PARAPET-UNIT F
17	BRGS & DIAPHRAGMS	47	SOUTH ABUTMENT-UNIT B
18	SUPERSTRUCTURE	48	SOUTH ABUTMENT-UNIT E
19	SUPERSTRUCTURE	49	NORTH ABUTMENT-UNIT C
20	SLAB ELEVATIONS	50	NORTH ABUTMENT-UNIT F
21	SLAB ELEVATIONS	51	PIER 1 - SOUTHBOUND
22	STRUCTURAL STEEL	52	PIER 1 - NORTHBOUND
23	BRGS & DIAPHRAGMS	53	PIER 2 - SOUTHBOUND
24	SUPERSTRUCTURE	54	PIER 2 - NORTHBOUND
25	SUPERSTRUCTURE	55	PIER 3 - SOUTHBOUND
26	SLAB ELEVATIONS	56	PIER 3 - NORTHBOUND
27	SLAB ELEVATIONS	57	PIER 3 - NORTHBOUND
28	STRUCTURAL STEEL	58	PIER 4 - SOUTHBOUND
29	BRGS & DIAPHRAGMS	59	PIER 4 - NORTHBOUND
30	SUPERSTRUCTURE	60	PIER 5 - SOUTHBOUND
31	SUPERSTRUCTURE	61	PIER 5 - NORTHBOUND
32	SLAB ELEVATIONS	62	PIER 6 - SOUTHBOUND
33	SLAB ELEVATIONS	63	PIER 6 - NORTHBOUND
34	STRUCTURAL STEEL	64	TEMPORARY SHEETING
35	BRGS & DIAPHRAGMS	65	PILE DETAILS

TOTAL BILL OF MATERIAL

ITEMS	SUPER	SUBST	TOTAL
Porous Granular Embankment	Cu. Yds.	250	250
Concrete Removal	Cu. Yds.	19	19
Class A Excav. for Struct	Cu. Yds.	1490	1490
Expansion Bolts 3/4"	Each	24	24
Class X Concrete	Cu. Yds.	1,754.6	4572.5
Structural Steel	Lbs.	1,993,140	1,993,140
Aluminum Handrail	Lin. Ft.	2,032	2,032
Reinforcement Bars	Lbs.	422,320	906,700
Creosoted Piles (over 38')	Lin. Ft.	1800	1800
Creosoted Piles (24'-38')	Lin. Ft.	19392	19392
Test Piles (Timber)	Each	2	2
Precast Concrete Piles 14"	Lin. Ft.	4634	4634
Test Piles (Prec. Conc.)	Each	11	11
Name Plates	Each	2	2
Slope Wall	Sq. Yds.	2,910	2,910
Protective Coat	Sq. Yds.	7,786	7,786
Concrete Piles	Lin. Ft.	3,553	3,553
Test Pile (Cone)	Ft.	3	3
Temporary Sheeting	Sq. Ft.	9841	9841

\*Includes excavation for Slope Wall.

GENERAL NOTES

Coarse aggregate to be used in parapet handrails and end posts must be absolutely free of chert, flint, limonite, lignite and soft sandstone.

The concrete floor slab shall be finished in accordance with Article 51.19 of the Standard Specifications.

Slope Wall shall be reinforced with welded wire fabric G\*G mesh weighing 58# per 100 Sq. Ft.

All reinforcement bars shall be lapped 20 diameters unless otherwise shown.

Rivets 3/4", Open holes 1 1/8", unless otherwise noted.

Anchor bolts shall be set before riveting diaphragms over supports.

The exposed surfaces of the expansion guards shall be given two shop coats of red lead paint, the contact surfaces shall be given one coat of red lead paint. Anchor studs shall not be painted.

Expansion guards are included in the quantity of Structural Steel. Est. Wt. 62,080 lbs.

Permanent forms will not be permitted in forming the concrete floor.

Except as otherwise provided, all structural steel shall receive one shop coat of red lead paint and two field coats of Aluminum paint. See Art. 56.1 to 56.5 inclusive of the Standard Specifications.

Concrete piles of abutments shall be driven in holes prepared through the embankment in accordance with Art. 60.9(C) of the Standard Specifications. Precore to natural ground at South Abut.

The contractor shall drive concrete test piles in permanent locations as directed by the engineer at So. Abut. Southbound Lanes, So. Abut. Northbound Lanes, No. Abut. Northbound Lanes and Pier 4 Northbound Lanes.

The contractor shall drive one timber test pile in the vicinity of Pier 2 Northbound Lanes and Pier 5 Southbound Lanes as directed by the engineer.

Roadway expansion guards shall be assembled in the shop in proper position, with ends in place and shall be left assembled for shop inspection.

Drive all test piles before ordering the remainder of piles. All exterior surfaces of the culvert extension of Pier 3 NB shall be waterproofed.

All structural steel shall conform to ASTM Designations A-36

DESIGNED	Jama Nearing
CHECKED	W. Nelson
DRAWN	W.E. Dickerson
CHECKED	J.N.

EXAMINED	JUNE 16 1966
PASSED	[Signature]
APPROVED	[Signature]

GEN. NOTES - TOTAL BILL OF MAT'L'S

S.B.I. ROUTE 53  
SEC. 531-2-VHB  
COOK COUNTY  
STATION 270+71.7

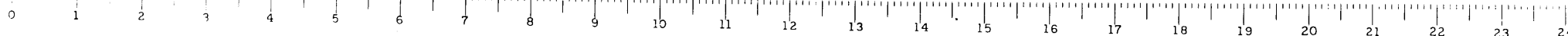

STATE OF ILLINOIS  
DEPARTMENT OF PUBLIC WORKS & BUILDINGS  
DIVISION OF HIGHWAYS

ROUTE NO.	SECTION	COUNTY	TOTAL SHEETS	SHEET NO.	SHEET NO.
S.B.I. 53	531-2	COOK	67	8	60 SHEETS
P.A. 61	VHB				
FED. ROAD DIST. NO. 7	ILLINOIS	FED. AID PROJECT			

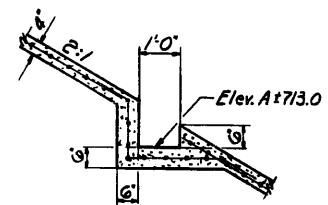
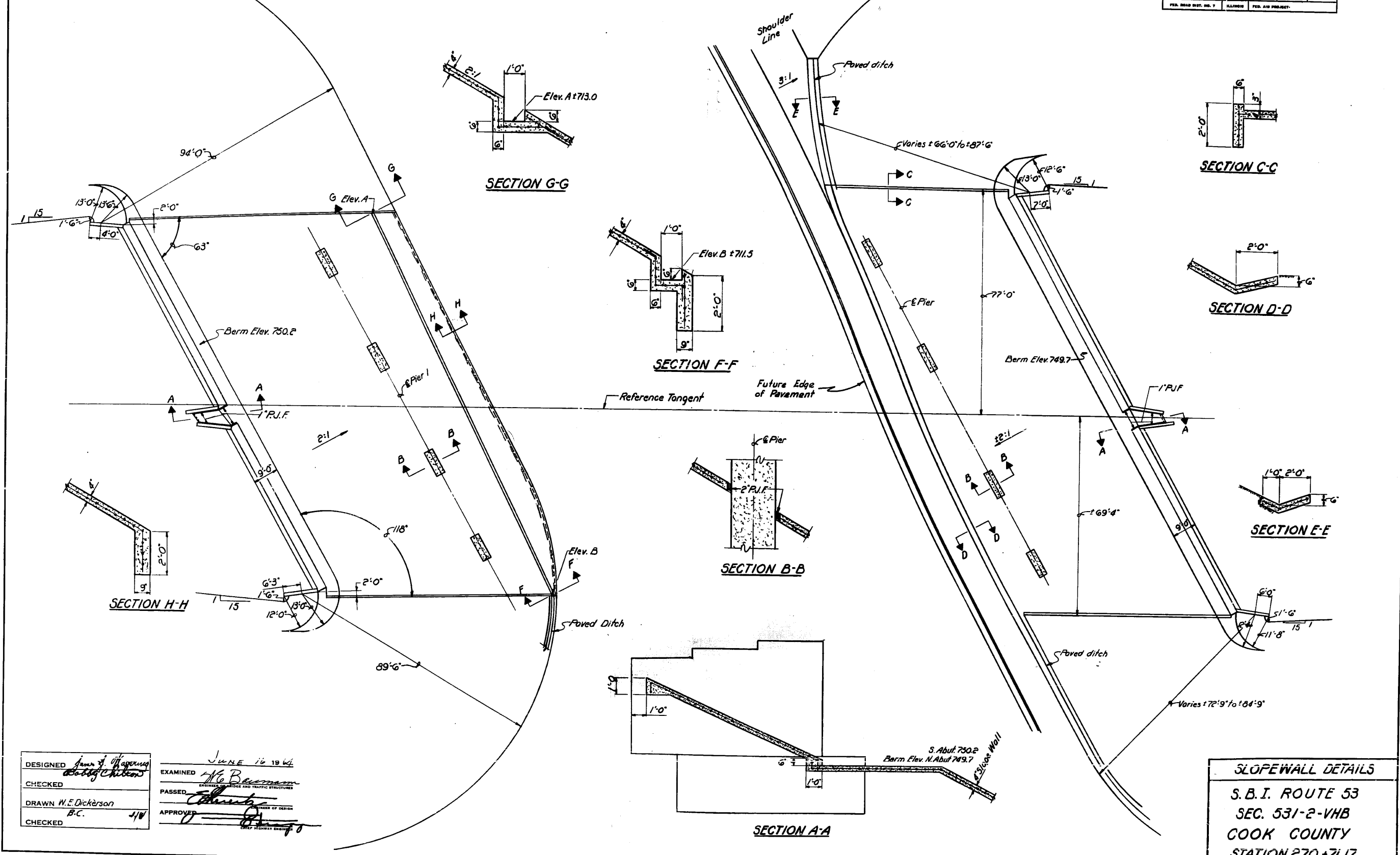

SECTION G-G

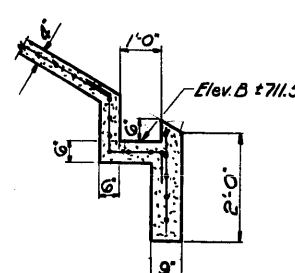

SECTION F-F

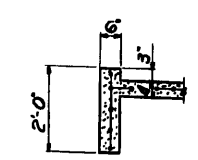

SECTION C-C

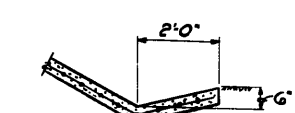

SECTION D-D

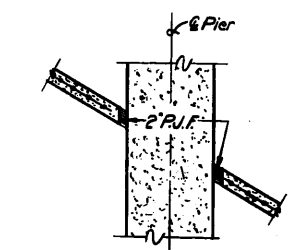

SECTION B-B

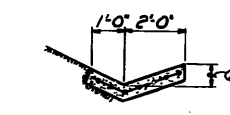

SECTION E-E

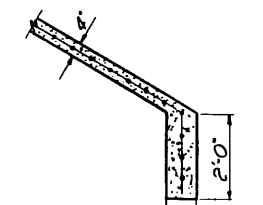

SECTION H-H

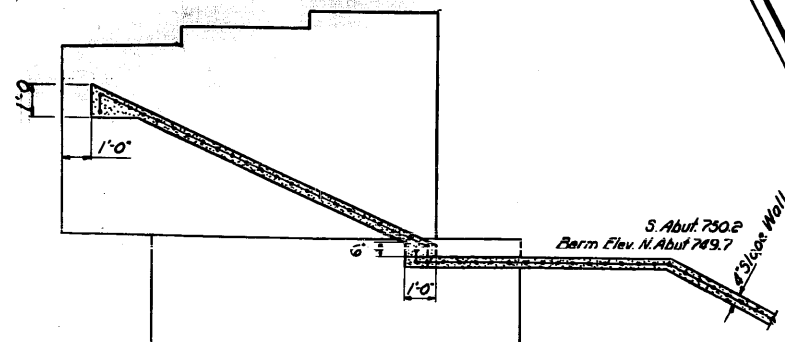

SECTION A-A

**SLOPEWALL DETAILS**  
S.B.I. ROUTE 53  
SEC. 531-2-VHB  
COOK COUNTY  
STATION 270+71.17

DESIGNED *James J. Hayward*  
CHECKED *W.E. Dickerson*  
DRAWN *W.E. Dickerson*  
CHECKED *B.C.*

EXAMINED *W.E. Dickerson*  
PASSED *W.E. Dickerson*  
APPROVED *W.E. Dickerson*

JUNE 16 1964

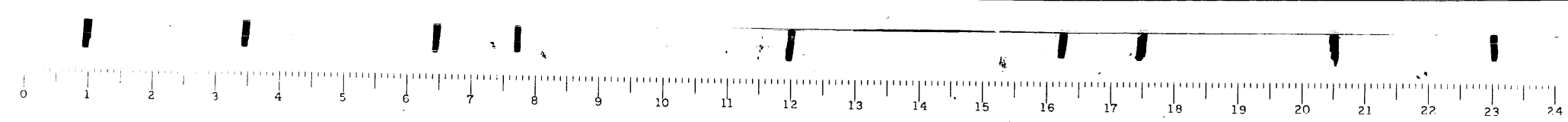

STATE OF ILLINOIS  
DEPARTMENT OF PUBLIC WORKS & BUILDINGS  
DIVISION OF HIGHWAYS

ROUTE NO. SECTION COUNTY TOTAL SHEETS SHEET NO.  
531-2 VHB COOK 67 9 60 SHEETS  
FED. ROAD DIST. NO. 1 ILLINOIS FED. AID PROJECT

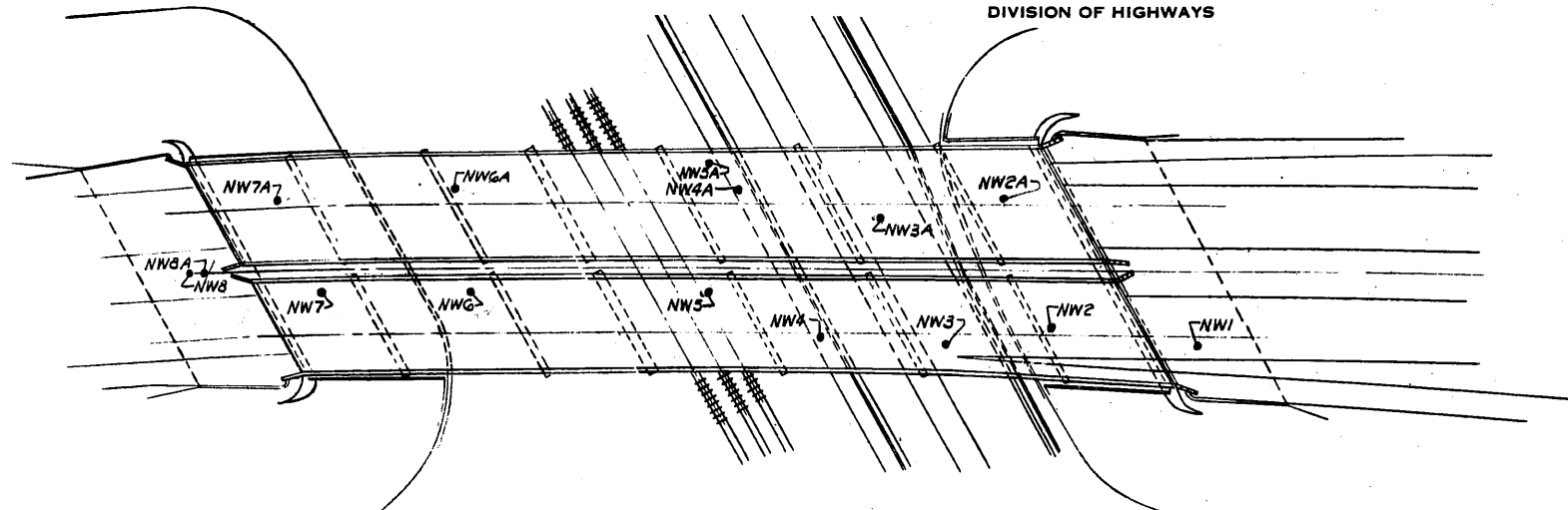

Boring No.	Station	Offset	Ground Surface Elevation	Surface Water E. After Hours	Groundwater E. at Completion	Soil Description	Depth (ft)	Moisture (%)	Penetration (lb/ft)
NW-7	267+00	5.0	721.7			GRAY SAND	0		
						BROWN CLAY FILL	0-2.33		
						BLACK CLAY LOAM	2.33-3.10		
						BROWN CLAY	3.10-3.88		
						BROWN SILTY CLAY	3.88-4.66		
						BROWNISH GRAY STONEY CLAY	4.66-5.44		
						GRAY STONEY CLAY	5.44-6.22		
						GRAY CLAYEY SILTY FINE SAND	6.22-7.00		
						GRAY CLAYEY SILTY FINE SAND	7.00-7.78		
						LAMINATIONS GRAY SILTY SAND CLAY	7.78-8.56		
						GRAY CLAY	8.56-9.34		
						GRAY CLAY LAYER OF GRAY CLAYEY SILTY SAND	9.34-10.12		
						END OF BORING	10.12		

Boring No.	Station	Offset	Ground Surface Elevation	Surface Water E. After Hours	Groundwater E. at Completion	Soil Description	Depth (ft)	Moisture (%)	Penetration (lb/ft)
NW-8	267+00	5.0	723.0			GRAY CLAY	0		
						BROWN CLAY FILL	0-1.63		
						GRAY CLAY	1.63-3.26		
						BLACK CLAY LOAM	3.26-4.89		
						BROWNISH GRAY CLAY	4.89-6.52		
						GRAY CRITTY CLAY	6.52-8.15		
						GRAY CRITTY CLAY LAYER OF GRAY SILT	8.15-9.78		
						GRAY SANDY SILT	9.78-11.41		
						GRAY SAND SILT	11.41-13.04		
						GRAY SILT	13.04-14.67		
						(LIVERFERRY) GRAY CLAYEY SANDY SILT	14.67-16.30		
						END OF BORING	16.30		

Boring No.	Station	Offset	Ground Surface Elevation	Surface Water E. After Hours	Groundwater E. at Completion	Soil Description	Depth (ft)	Moisture (%)	Penetration (lb/ft)
NW-7A	267+11	4.0	719.0			GRAY CLAY	0		
						BLACK MUCK	0-2.72		
						BROWN CLAY FILL	2.72-3.50		
						BROWN CLAY GRAY CLAY	3.50-4.28		
						BROWNISH GRAY CLAY	4.28-5.06		
						LAYER OF SAND & GRAVEL GRAY CLAY	5.06-5.84		
						FINE GRAY SAND	5.84-6.62		
						GRAY CLAYEY SILTY SAND	6.62-7.40		
						GRAY SILTY SANDY CLAY	7.40-8.18		
						WASHER	8.18-8.96		
						GRAY SILTY SAND	8.96-9.74		
						LAYER OF SILTY SANDY CLAY	9.74-10.52		
						END OF BORING	10.52		

DESIGNED  
CHECKED  
DRAWN W.E. Dickerson  
CHECKED J.B. Mc...

EXAMINED  
PASSED  
APPROVED  
JUNE 14 1964  
W.E. Beermann  
Thurman  
U.S. ENGINEER

N - Standard Penetration Test - Blows per foot to drive 2" O.D. Split Spore Sampler 12" with 140# hammer falling 30".  
Cu - Uncorrected Compressive Strength - 1/4"  
w - Water Content - percentage of oven dry weight - %

Type failure:  
B - Bulge Failure  
S - Shear Failure  
E - Estimated Value

BORINGS  
S.B.I. ROUTE 53  
SEC. 531-2-VHB  
COOK COUNTY  
STATION 270+71.7

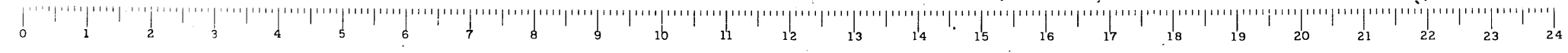

STATE OF ILLINOIS  
DEPARTMENT OF PUBLIC WORKS & BUILDINGS  
DIVISION OF HIGHWAYS

ROUTE NO. S.B.I. 53 S.E. 47	SECTION 531-2 -VHB	COUNTY COOK	TOTAL SHEETS 67	SHEET NO. 10	SHEET NO. 5 60 SHEETS
-----------------------------------	--------------------------	----------------	--------------------	-----------------	--------------------------

Surface Water Elev. 4'

Surface Water Elev. 4'

Surface Water Elev. 5'

Depth	Soil Description	Moisture %	Specific Gravity	Notes
0	Ground Surface	718.0		
1	BROWN CLAY FILL	NO TEST		
2	BLACK CLAY LOAM	NO TEST		
3	BLACK TO GRAY LOAM	1.98 B		
4	GRAY CLAY	1.98 B		
5	GRAY CLAYEY SANDY SILT	1.30 B		
6	GRAY CLAYEY SANDY SILT	1.13 B		
7	GRAY CLAYEY SANDY SILT	NO TEST		
8	LAYER OF GREEN SILTY CLAY	2.82 B		
9	HEAVY STONEY CLAY	2.82 B		
10	GRAY CLAY	2.72 B		
11	GRAY CLAY	2.51 B		
12	GRAY CLAY	1.63 B		
13	GRAY STONEY CLAY	4.80 B		
14	GRAY CLAY	4.05 B		
15	GRAY CLAY	4.05 B		
16	GRAY CLAY	3.88 B		
17	Gray	2.72 B		
18	HEAVY STONEY CLAY	2.72 B		
19	END OF BORING			

Depth	Soil Description	Moisture %	Specific Gravity	Notes
0	Ground Surface	711.6		
1	BROWN CLAY FILL	NO TEST		
2	BLACK CLAY LOAM	1.48 B		
3	GRAY CRISTY CLAY	1.65 B		
4	GRAY CRISTY CLAY	1.30 B		
5	BROWN CRISTY CLAY	2.82 B		
6	GRAY W/ SAND	NO TEST		
7	LAYER OF SAND	NO TEST		
8	LAYER OF SAND	NO TEST		
9	GRAY CLAY	1.30 B		
10	GRAY CLAY	1.63 B		
11	GRAY CLAY	1.63 B		
12	THIN LAYER OF SAND & GRAVEL	2.13 B		
13	GRAY CLAY	2.13 B		
14	GRAY CLAY	2.82 B		
15	GRAY CLAY	7.18 B		
16	GRAY CLAY	5.02 B		
17	END OF BORING			

Depth	Soil Description	Moisture %	Specific Gravity	Notes
0	Ground Surface	712		
1	CLAY FILL			
2	BLACK & GRAY MOTTLED CLAY	1.81 B		
3	BLACK & GRAY CLAY	1.89 B		
4	BLACK & GRAY CLAY	1.89 B		
5	GRAVELLY GRAY CLAY	2.33 B		
6	BROWN & GRAY SILTY CLAY	1.63 B		
7	GRAY CLAYEY SILTY SAND	NO TEST		
8	GRAY CLAYEY SILTY SAND	NO TEST		
9	GRAY CLAY	2.52 B		
10	GRAY CLAY	2.13 B		
11	GRAY CLAY	2.13 B		
12	GRAY STONEY CLAY	2.91 B		
13	GRAY CLAY	3.30 B		
14	GRAY CLAY	2.52 B		
15	GRAY CLAY	2.52 B		
16	LAMINATED LAYERS OF BROWN & GRAY CLAYEY SILT	2.33 B		
17	GRAY CLAY	4.65 B		
18	GRAY CLAY	2.52 B		
19	GRAY CLAY	2.52 B		
20	END OF BORING			

Depth	Soil Description	Moisture %	Specific Gravity	Notes
0	Ground Surface	713.0		
1	BLACK CLAY	NO TEST		
2	LOAM	NO TEST		
3	BLACK TO GRAY CLAY	NO TEST		
4	GRAY CLAY	1.81 B		
5	LAMINATED GRAY SAND & SILT	1.65 B		
6	LAYER OF GRAY SAND	2.52 B		
7	LAYER OF SILT & SAND	2.52 B		
8	GRAY CLAY	2.52 B		
9	GRAY CLAY	2.52 B		
10	GRAY CLAY	1.63 B		
11	GRAY CLAY	3.00 P		
12	GRAY CLAY	2.91 B		
13	GRAY CLAY	3.00 P		
14	GRAY CLAY	3.00 P		
15	GRAY CLAY	3.00 P		
16	GRAY CLAY	3.00 P		
17	GRAY CLAY	3.00 P		
18	GRAY CLAY	3.00 P		
19	END OF BORING			

Depth	Soil Description	Moisture %	Specific Gravity	Notes
0	Ground Surface	714.0		
1	BLACK CLAY LOAM	NO TEST		
2	BLACK TO GRAY CLAY	1.33 B		
3	GRAY CLAY	1.49 B		
4	GRAY CLAY	1.63 B		
5	LAYER OF GRAY SAND	1.73 B		
6	LAYER OF GRAY SAND	1.63 B		
7	LAYER OF GRAY SAND	1.63 B		
8	GRAY CLAY	3.00 P		
9	GRAY CLAY	3.00 P		
10	GRAY CLAY	3.00 P		
11	GRAY CLAY	3.00 P		
12	GRAY CLAY	3.00 P		
13	GRAY CLAY	3.00 P		
14	GRAY CLAY	3.00 P		
15	GRAY CLAY	3.00 P		
16	GRAY CLAY	3.00 P		
17	GRAY CLAY	3.00 P		
18	GRAY CLAY	3.00 P		
19	END OF BORING			

DESIGNED  
CHECKED  
DRAWN *W.E. Dickerson*  
CHECKED *J.B. Nelson*

JUNE 16 1966  
EXAMINED *H.E. B...*  
PASSED *[Signature]*  
APPROVED *[Signature]*

BORINGS  
S.B.I. ROUTE 53  
SEC. 531-2-VHB  
COOK COUNTY  
STATION 270+71.7

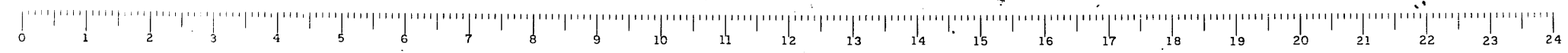

STATE OF ILLINOIS  
DEPARTMENT OF PUBLIC WORKS & BUILDINGS  
DIVISION OF HIGHWAYS

Surface Water Elev. -15'  
After 72 hrs -4'

ROUTE NO.	SECTION	COUNTY	TOTAL SHEETS	SHEET NO.	SHEET NO. G
61	531-2	COOK	67	11	60 SHEETS
P.L. 61 - VHB		FOR ROAD DIST. NO. 7			

Surface Water Elev. -4'

Soil Description	Depth (ft)	Moisture (%)	Notes
BLACK CLAY LOAM	0-1		
BLACK CLAY LOAM	1-2	75	B
BLACK CLAY LOAM	2-5	78	B
BLACKISH GRAY CLAY	5-7	78	B
GRAY GRITTY CLAY	7-10	78	B
GRAY GRITTY CLAY	10-14	78	B
BROWN & GRAY SANDY CLAY	14-16	78	B
LAYER OF GRAY SAND & SILT	16-17		B
WASHED GRAY SAND & GRAVEL	17-20		No Test
GRAY SILTY SANDY GRAVEL	20-23		No Test
GRAY CLAY	23-26		B
GRAY CLAY	26-27		B
GRAY CLAY	27-28		B
GRAY STONEY CLAY	28-31		B
GRAY GRITTY CLAY	31-33		B
GRAY SILTY GRAVELLY CLAY	33-35		B
GRAY STONEY SILTY CLAY	35-36		B
END OF BORING			

Surface Water Elev. -4'

Soil Description	Depth (ft)	Moisture (%)	Notes
BLACK CLAY LOAM	0-1		
BLACK CLAY LOAM	1-2	75	P
BLACK CLAY LOAM	2-3	51	P
GRAY SILTY SANDY CLAY	3-5	50	P
GRAY CLAY	5-7	75	P
GRAY CLAY	7-9	2.1	B
BROWNISH GRAY GRITTY CLAY	9-10	4.07	B
GRAY STRATIFIED SILT & CLAY	10-11	2.72	B
GRAY CLAYEY SILTY SAND TO GRAY CLAY	11-12	1.63	B
GRAY CLAYEY SILTY SANDY GRAVEL	12-13		No Test
WASHED GRAY SAND & GRAVEL	13-14		No Test
GRAY CLAYEY SAND & GRAVEL	14-15		No Test
LAYER OF SAND	15-16		
GRAY GRITTY CLAY	16-17	4.65	B
GRAY CLAY	17-18	2.13	B
GRAY CLAY	18-19	8.33	B
GRAY GRITTY CLAY	19-21	6.01	B
GRAY CLAY	21-23	7.76	B
GRAY CLAY	23-25	8.53	B
GRAY CLAY	25-27	8.53	B
GRAY CLAY	27-28	5.82	B
END OF BORING			

Surface Water Elev. -4'

Soil Description	Depth (ft)	Moisture (%)	Notes
BLACK CLAY LOAM	0-1		
BLACK CLAY LOAM	1-2	No Test	
BLACK & GRAY MOTTLED CLAY	2-3	No Test	
BLACK & GRAY MOTTLED CLAY	3-4	1.43	B
GRAY CLAY	4-6	2.13	B
GRAY CLAYEY CLAY	6-9	3.30	B
GRAY GRITTY CLAY	9-10	3.49	B
GRAY GRITTY CLAY	10-11	3.10	B
GRAY SANDY CLAY	11-12	1.54	P
GRAY SANDY SILTY CLAY	12-13	2.69	B
GRAY SILTY CLAY	13-14	2.13	B
LAYER OF GRAVEL & SAND	14-15		S
GRAY SAND & GRAVEL	15-16	No Test	
GRAY SAND & GRAVEL	16-17	No Test	
GRAY CLAY	17-18	2.91	B
GRAY CLAY	18-19	2.92	B
GRAY CLAY	19-20	2.92	B
GRAY CLAY	20-21	2.89	B
GRAY CLAY	21-22	3.49	B
GRAY CLAY	22-23	4.07	B
GRAY CLAY	23-24	2.13	B
GRAY CLAY	24-25	4.65	B
GRAY CLAY	25-26	4.65	B
END OF BORING			

Surface Water Elev. -5'

Soil Description	Depth (ft)	Moisture (%)	Notes
CONCRETE & GRAVEL	0-1		
BLACK CLAY LOAM	1-2	1.11	B
BROWN & GRAY MOTTLED CLAY	2-3	65	B
BR & GRAY MOTTLED	3-5	1.11	B
GRAVELLY GRAY CLAY	5-7	1.11	B
GRAVELLY GRAY CLAY	7-9	5.38	B
FINELY GRAY CLAY	9-11	3.49	B
FINELY GRAY CLAY	11-12	3.16	B
GRAY CLAYEY SANDY SILT	12-13	1.54	P
GRAY SANDY SILTY CLAY	13-14	3.10	B
GRAY SILTY CLAY	14-15	2.13	P
GRAY CLAYEY GRAVEL	15-16	3.50	P
GRAY CLAY	16-17	6.21	B
GRAY CLAY	17-18	2.72	B
GRAY CLAY	18-19	2.91	B
GRAY CLAY	19-20	2.72	B
GRAY CLAY	20-21	3.49	B
GRAY CLAY	21-22	4.07	B
GRAY CLAY	22-23	3.10	B
GRAY CLAY	23-24	3.10	B
GRAY CLAY	24-25	4.65	B
GRITTY GRAY CLAY	25-26	4.65	B
END OF BORING			

Surface Water Elev. -15'

Soil Description	Depth (ft)	Moisture (%)	Notes
GRAVEL & CONCRETE	0-1		
BLACK CLAY LOAM	1-2	No Test	
BLACK, BROWN & GRAY MOTTLED CLAY	2-3	78	P
BROWN & YELLOW GRITTY CLAY	3-5	2.72	B
FINELY GRAY CLAY w/ TRACES OF BR CLAY	5-7	2.71	B
GRITTY GRAY CLAY	7-9	2.33	B
GRITTY GRAY CLAY	9-10	3.10	B
GRITTY GRAY CLAY	10-11	2.71	B
LAYER OF GRAY SAND & GRAY CLAYEY SILT	11-12	8.1	B
GRAY SILTY CLAY w/ TRACES OF BR CLAY	12-13	1.17	B
GRAY SILTY CLAY	13-14	2.13	B
GRAY CLAYEY GRAVELLY SILTY SAND	14-15	1.63	B
GRAY CLAY	15-16	No Test	
GRAY CLAY	16-17	3.30	B
GRAY CLAY	17-18	2.33	B
GRAY CLAY	18-19	3.10	B
LAYER OF GRAY SAND & GRAY CLAY	19-20	2.33	B
GRAY CLAY	20-21	3.03	B
GRAY CLAY	21-22	2.13	B
LAYER OF SILT	22-23		
GRAY CLAY	23-24	1.31	B
GRAY CLAY w/ SHALE CONC.	24-25	5.21	B
GRAY CLAY w/ STONES	25-26	5.21	B
GRITTY GRAY CLAY	26-27	3.30	B

Surface Water Elev. -15'

Soil Description	Depth (ft)	Moisture (%)	Notes
GRAY CLAY	0-1		
GRAY CLAY	1-2		
GRAY CLAY w/ LENSES OF SILT & SAND	2-3		
FINELY BROWN CLAY	3-4	4.27	B
FINELY BROWN CLAY	4-5	3.00	B
GRITTY GRAY CLAY	5-6	3.49	B
GRITTY GRAY CLAY	6-7	2.72	B
LAYER OF WELL GRADED FINE GRAY SAND & GRAY SILTY SANDY CLAY	7-8	2.50	P
LAYER OF CLAYEY SILTY SAND & GRAY CLAY	8-9	1.30	B
VERY COMPRESSIBLE GRAY CLAY	9-10	5.01	B
GRAY CLAY	10-11	1.63	B
GRAY CLAY	11-12	3.03	B
GRAY CLAY	12-13	1.63	B
GRAY CLAY	13-14	1.63	B
GRAY CLAY	14-15	1.78	B
GRAY CLAY w/ GRAVEL	15-16	3.10	B
GRAY CLAY	16-17	2.33	B
GRAY CLAY	17-18	3.10	B
GRAY CLAY	18-19	3.03	B
GRAY CLAY	19-20	5.82	B
GRAY CLAY	20-21	5.82	B

Soil Description	Depth (ft)	Moisture (%)	Notes
GRAY CLAY	10-11	5.01	
GRAY CLAY	11-12		
GRAY CLAY w/ LENSES OF SILT & SAND	12-13		
END OF BORING			5/1/63 11: AM

DESIGNED	
CHECKED	
DRAWN	W.E. Dickerson
CHECKED	J.D. N.

JUNE 16 1966  
EXAMINED  
PASSED  
APPROVED

BORINGS  
S.B.I. ROUTE 53  
SEC. 531-2-VHB  
COOK COUNTY  
STATION 270+71.7

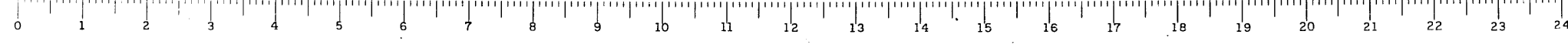



STATE OF ILLINOIS  
DEPARTMENT OF PUBLIC WORKS & BUILDINGS  
DIVISION OF HIGHWAYS

ROUTE NO.	SECTION	COUNTY	TOTAL SHEETS	SHEET NO.	SHEET NO. 7
S.B.I. 53	531-2	COOK	67	12	60 SHEETS
P.F. 51	VHB				
FED. ROAD DIST. NO. 7	ILLINOIS	FED. AID PROJECT			

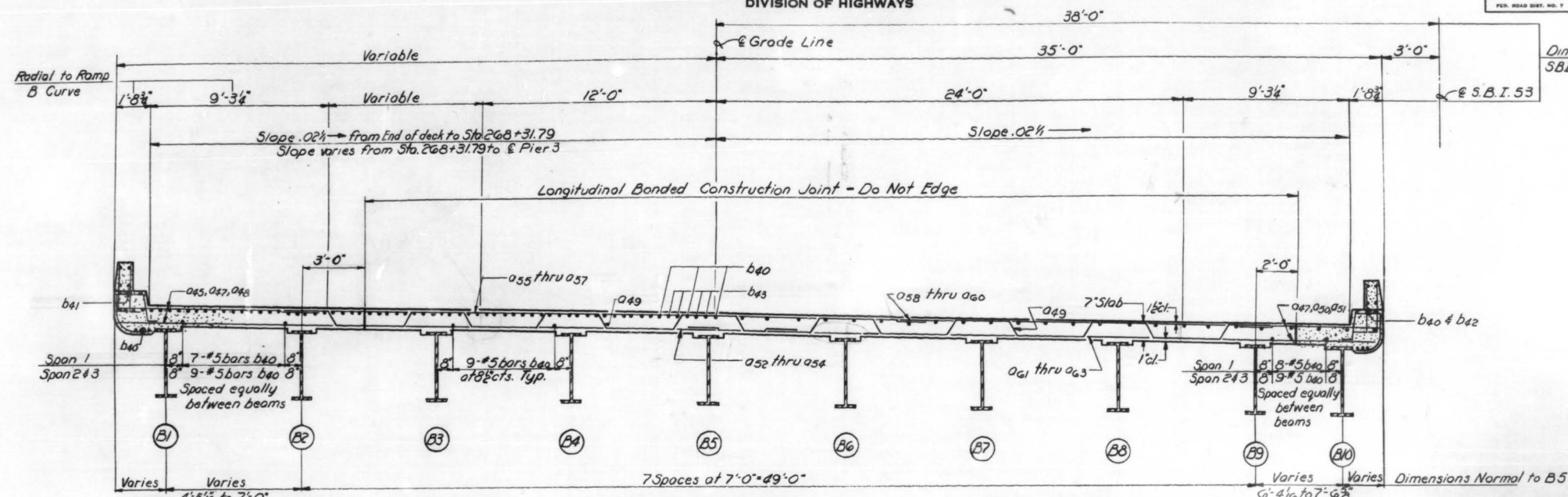

Dimensions Radial to SBI 53 Curve except as noted

NEAR PIER

NEAR MIDSPAN

CROSS SECTION

BILL OF MATERIAL

Bar	No.	Size	Length	Shape
a49	280	#6	27'-8"	---
a50	56	#6	10'-3"	---
a51	56	#6	10'-9"	---
a52	28	#6	29'-9"	---
a53	28	#6	30'-3"	---
a54	136	#6	30'-9"	---
a55	28	#6	40'-3"	---
a56	28	#6	40'-9"	---
a57	136	#6	41'-3"	---
a58	83	#6	27'-3"	---
a59	28	#6	27'-9"	---
a60	81	#6	28'-3"	---
a61	83	#6	37'-9"	---
a62	28	#6	38'-3"	---
a63	81	#6	38'-9"	---
a64	56	#6	8'-8"	---
a65	336	#6	9'-10"	---
a66	56	#6	9'-2"	---
b40	1075	#5	27'-6"	---
b41	24	#5	10'-6"	---
b42	12	#5	30'-6"	---
b43	178	#6	23'-6"	---
c41	332	#5	5'-6"	---
d40	958	#5	2'-8"	---
* Reinforcement Bars		Lbs.	103,380	
** Structural Steel		Lbs.	393,680	
Class X Concrete		Cu. Yds.	368.0	

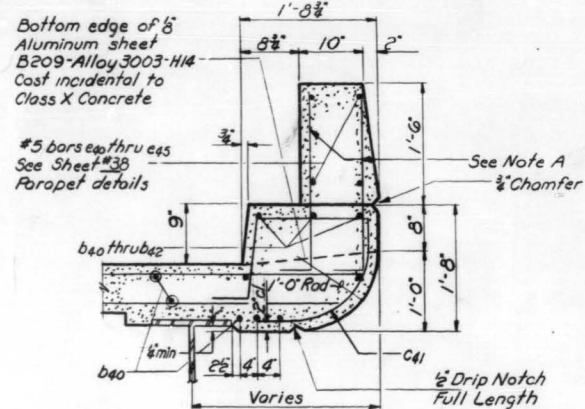

CURB DETAIL

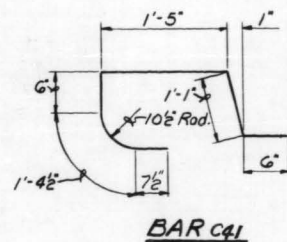

BAR C41

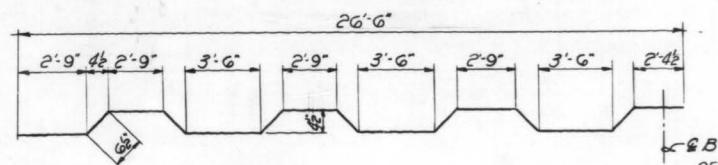

BAR a49

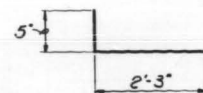

BAR d40

Work this sheet with following sheet

DESIGNED *Sobby Christen*  
CHECKED *John G. ...*  
DRAWN *W.E. Dickerson*  
CHECKED *JWW*

EXAMINED *H.C. Beaman*  
PASSED *[Signature]*  
APPROVED *[Signature]*  
JUNE 16 1964

\*\* Structural Steel quantity includes the following  
1) Bearing Assemblies, including lead plates and anchor bolts. Est. Wt. 11,930 lbs.  
2) Sliding plate Expansion Device - includes all material attached (directly or indirectly) to diaphragms of the unit and to theabut. Est. Wt. 13,000 lbs.  
\* Reinforcement Bars quantity includes e series bars in parapet.

**SUPERSTRUCTURE-UNIT B**  
S.B.I. ROUTE 53  
SEC. 531-2-VHB  
COOK COUNTY  
STATION 270+71.17



STATE OF ILLINOIS  
DEPARTMENT OF PUBLIC WORKS & BUILDINGS  
DIVISION OF HIGHWAYS

ROUTE NO.	SECTION	COUNTY	TOTAL SHEETS	SHEET NO.
531-2	VHB	COOK	67	13
SHEET NO. 8				
60 SHEETS				

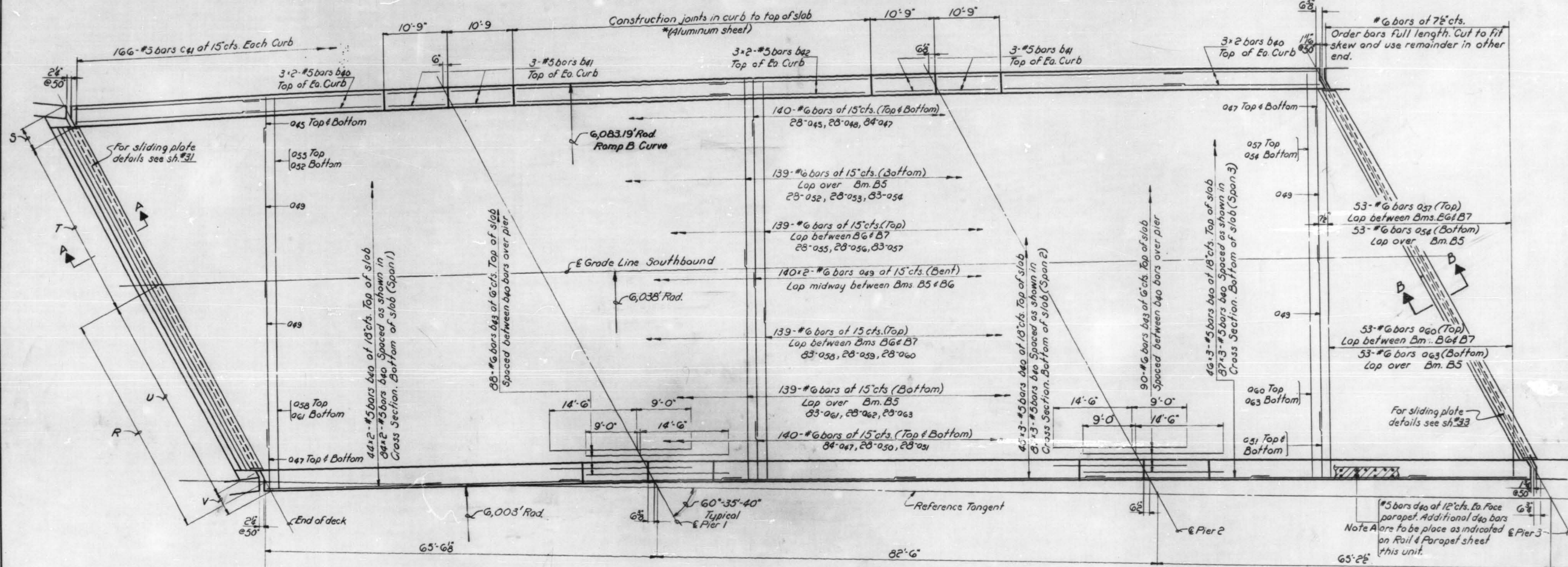

PLAN

Note:  
Bars indicated thus 20x3-#5 etc.  
indicates 20 lines of bars with  
3 lengths per line. Lap all a series  
bars min. of 2'-0". Lap all b series  
bars min. of 20 diameters.  
\*Aluminum sheets to be placed  
normal to water table

Location	R	S	T	U	V
End of deck	37'-8 1/2"	1'-11 1/2"	31'-7 3/4"	37'-4 1/2"	1'-11 1/2"
± Pier 1	40'-4 1/2"	1'-11 1/2"	32'-10 3/8"	37'-7"	1'-11 1/2"
± Pier 2	42'-7"	1'-11 1/2"	34'-5 3/8"	37'-10 1/4"	1'-11 1/2"
± Pier 3	43'-5 1/4"	1'-11 1/2"	35'-8 3/8"	38'-1"	1'-11 1/2"

Hatched area to be poured  
after superstructure forms  
have been removed.  
Quantity of Class X Concrete  
included with superstructure

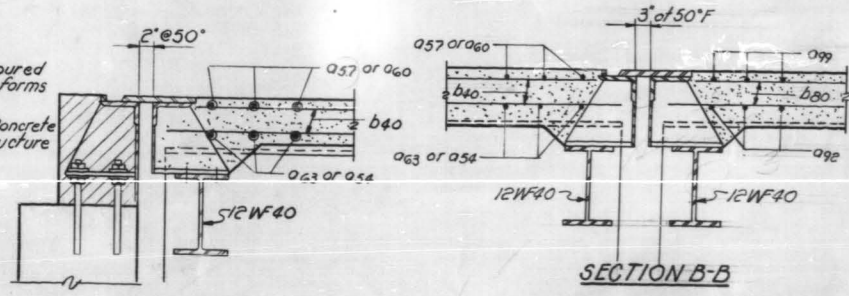

SECTION A-A

SECTION B-B

DESIGNED *Bobbi Chisbon*  
CHECKED *J. Wawrony*  
DRAWN *W.E. Dickerson*  
CHECKED *B.C. JW*

EXAMINED *W.G. Baumann*  
PASSED *[Signature]*  
APPROVED *[Signature]*  
JUNE 16 1964

SUPERSTRUCTURE-UNIT B  
S.B.I. ROUTE 53  
SFC. 531-2-VHB  
COOK COUNTY  
STATION 270+71.17

Work this with  
preceding sheet.





STATE OF ILLINOIS  
DEPARTMENT OF PUBLIC WORKS & BUILDINGS  
DIVISION OF HIGHWAYS

ROUTE NO.	SECTION	COUNTY	TOTAL SHEETS	SHEET NO.
53	531-2	COOK	67	14
SHEET NO. 9				
60 SHEETS				

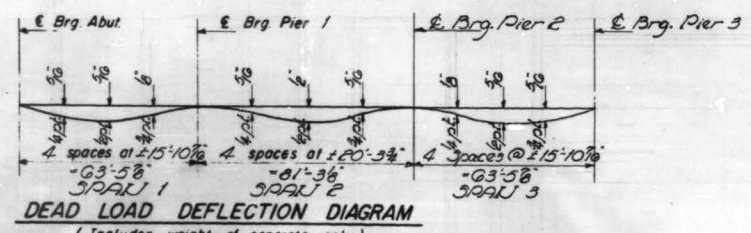
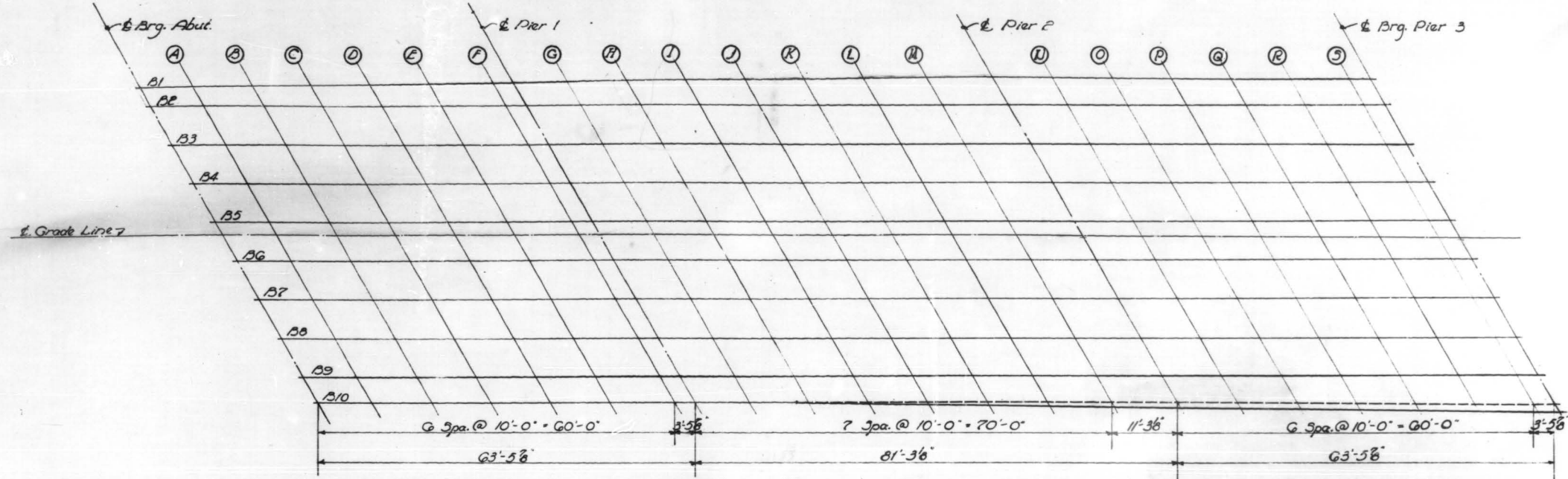

Beam	Station	Offset	Theoretical Grade Elevations	Theoretical Grade Elevations Adjusted For Dead Load Deflection	
Abut. Brg.	B1	26670.733	27.843	756.312	756.312
A	B1	26680.498	27.530	756.381	756.396
B	B1	26690.276	28.034	756.448	756.472
C	B1	26700.047	28.152	756.512	756.538
D	B1	26709.819	28.288	756.575	756.593
E	B1	26719.588	28.439	756.635	756.644
F	B1	26729.257	28.606	756.693	756.696
Pier 1	B1	26732.767	28.668	756.714	756.714
G	B1	26742.636	28.858	756.769	756.782
H	B1	26752.300	29.029	756.822	756.848
I	B1	26762.181	29.075	756.871	756.905
J	B1	26772.042	29.131	756.912	756.959
K	B1	26781.925	29.204	756.961	756.996
L	B1	26791.766	29.292	757.003	757.030
M	B1	26801.627	29.398	757.043	757.057
Pier 2	B1	26812.731	29.436	757.085	757.085
N	B1	26822.592	29.676	757.121	757.127
O	B1	26832.452	29.833	757.150	757.164
P	B1	26842.311	30.006	757.122	757.146
Q	B1	26852.170	30.195	757.091	757.116
R	B1	26862.028	30.401	757.058	757.078
S	B1	26871.886	30.623	757.021	757.026
Brig.-Pier 3	B1	26879.325	30.706	757.007	757.007

Beam	Station	Offset	Theoretical Grade Elevations	Theoretical Grade Elevations Adjusted For Dead Load Deflection	
Abut. Brg.	B10	26701.286	32.325	755.310	755.310
A	B10	26711.276	32.423	755.369	755.384
B	B10	26721.266	32.503	755.426	755.451
C	B10	26731.257	32.568	755.481	755.507
D	B10	26741.248	32.615	755.533	755.551
E	B10	26751.239	32.646	755.583	755.592
F	B10	26761.230	32.660	755.631	755.634
Pier 1	B10	26771.221	32.661	755.648	755.648
G	B10	26781.212	32.653	755.693	755.706
H	B10	26791.203	32.642	755.733	755.758
I	B10	26794.749	32.697	755.772	755.809
J	B10	26804.790	32.735	755.811	755.854
K	B10	26814.833	32.755	755.847	755.882
L	B10	26824.875	32.762	755.879	755.906
M	B10	26834.917	32.745	755.910	755.924
Pier 2	B10	26843.225	32.710	755.941	755.941
N	B10	26853.267	32.661	755.967	755.973
O	B10	26866.308	32.596	755.991	755.996
P	B10	26876.350	32.513	756.013	756.017
Q	B10	26886.391	32.413	756.031	756.036
R	B10	26896.432	32.297	756.048	756.068
S	B10	26906.473	32.081	756.063	756.069
Brig.-Pier 3	B10	26909.978	32.117	756.068	756.068

Elevations shown are along E beams.

DESIGNED James Manning  
CHECKED Bob Chilton  
DRAWN jacob3  
CHECKED JVV

EXAMINED H.G. Baumann  
PASSED [Signature]  
APPROVED [Signature]

JUNE 16 1964

SLAB ELEVATIONS - UNIT B  
S.B.I. ROUTE 53  
SEC. 531-2-VHB  
COOK COUNTY  
STA. 270+71.7

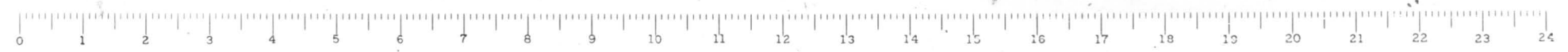





STATE OF ILLINOIS  
DEPARTMENT OF PUBLIC WORKS & BUILDINGS  
DIVISION OF HIGHWAYS

ROUTE NO.	SECTION	COUNTY	TOTAL SHEETS	SHEET NO.
53	531-2	COOK	67	16
1-1	VHB			
ILLINOIS		FED. AID PROJECT		

SHEET NO. 11  
60 SHEETS

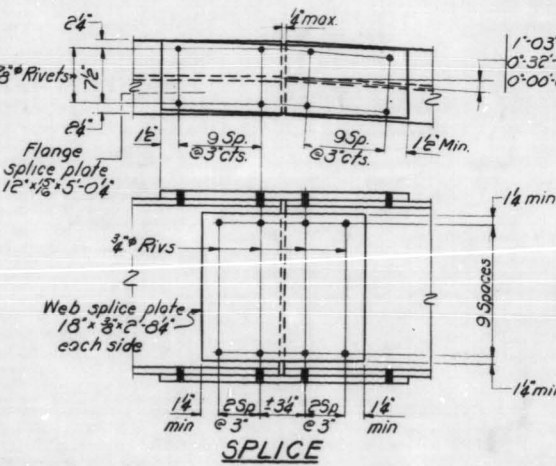
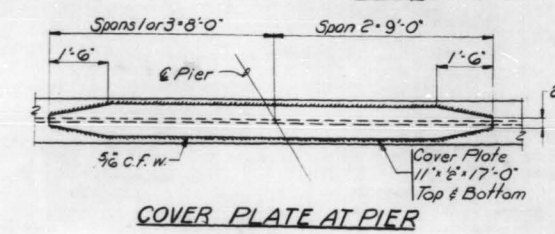
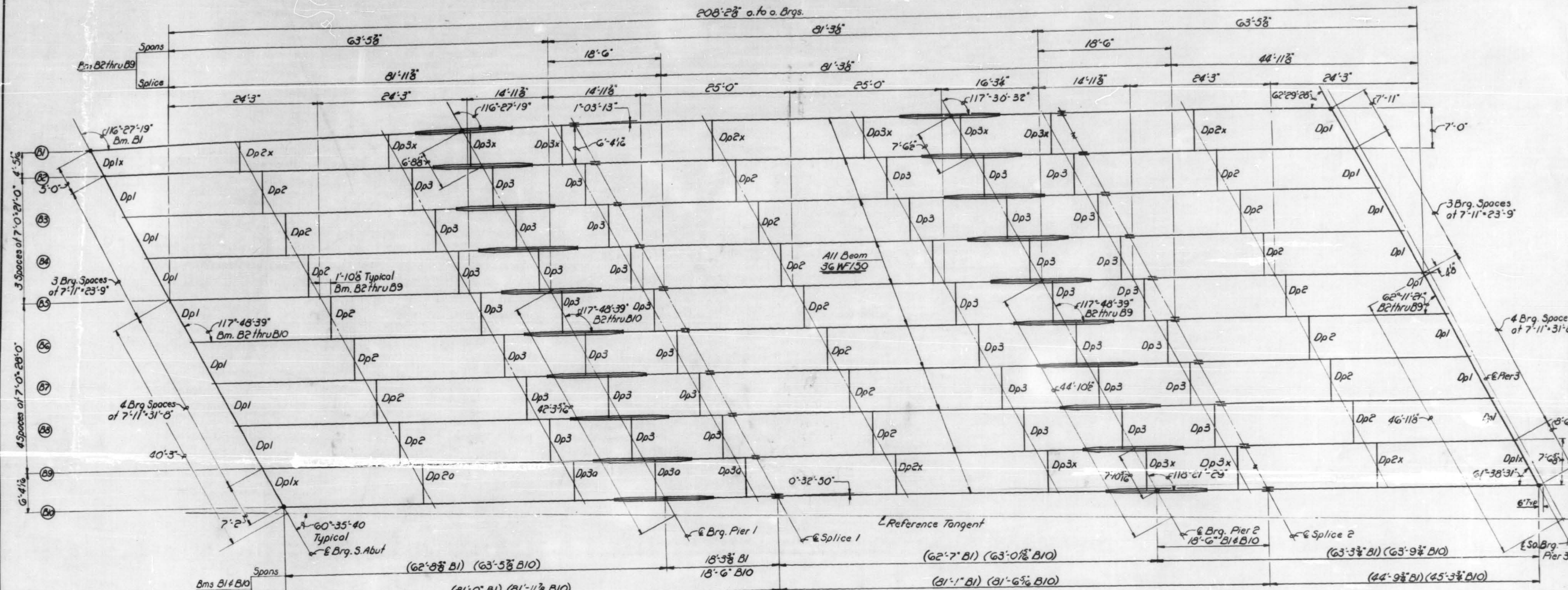

STRUCTURAL STEEL LAYOUT

TOP OF BEAM ELEVATIONS

Beam	So. Abut. Brg.	Pier 1	Splice 1	Pier 2	Splice 2	So. Brg. Pier 3
B1	755.74	756.05	756.14	756.35	756.42	756.30
B2	755.66	755.97	756.06	756.27	756.34	756.22
B3	755.55	755.86	755.95	756.16	756.23	756.27
B4	755.43	755.74	755.83	756.04	756.11	756.15
B5	755.31	755.62	755.71	755.92	755.99	756.03
B6	755.18	755.49	755.58	755.79	755.86	755.90
B7	755.06	755.37	755.46	755.67	755.74	755.78
B8	754.93	755.24	755.33	755.54	755.61	755.63
B9	754.80	755.11	755.20	755.41	755.48	755.52
B10	754.67	754.98	755.07	755.28	755.35	755.39

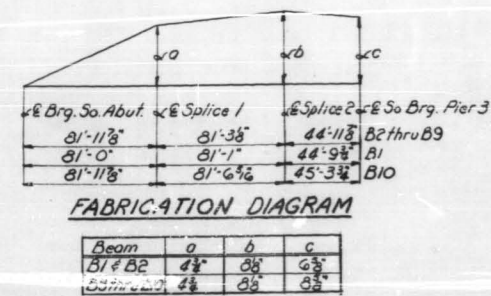

FABRICATION DIAGRAM

Beam	a	b	c
B1 & B2	4 1/2	2 1/2	6 3/4
B3 thru B10	4 1/2	2 1/2	8 3/4

STRUCTURAL STEEL-UNIT B  
S.B.I. ROUTE 53  
SEC. 531-2-VHB  
COOK COUNTY  
STATION 270+71.17

DESIGNED: James Manning  
EXAMINED: W.E. Dickerson  
CHECKED: Thomas...  
DRAWN: W.E. Dickerson  
APPROVED: [Signature]

JUNE 16 1964





STATE OF ILLINOIS  
DEPARTMENT OF PUBLIC WORKS & BUILDINGS  
DIVISION OF HIGHWAYS

DATE	BY	CHECKED	SCALE	SHEET NO.
5/11/66	J.W.	G.R.	AS SHOWN	12
5/11/66	J.W.	G.R.	AS SHOWN	60 SHEETS

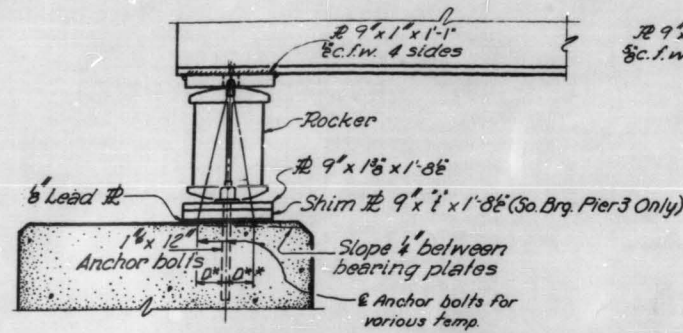

**ELEVATION**

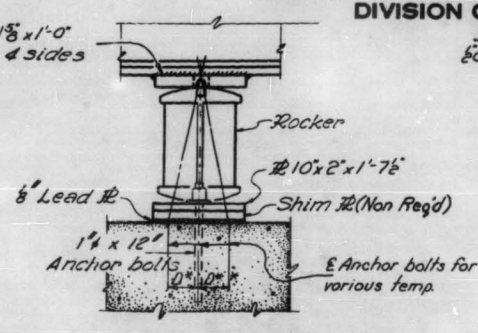

**ELEVATION**

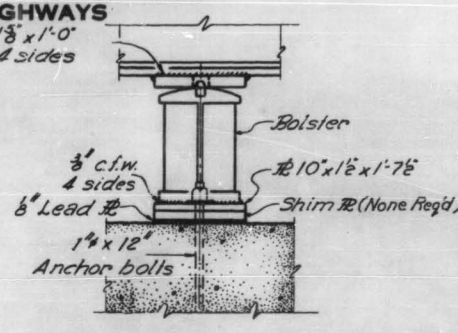

**ELEVATION**

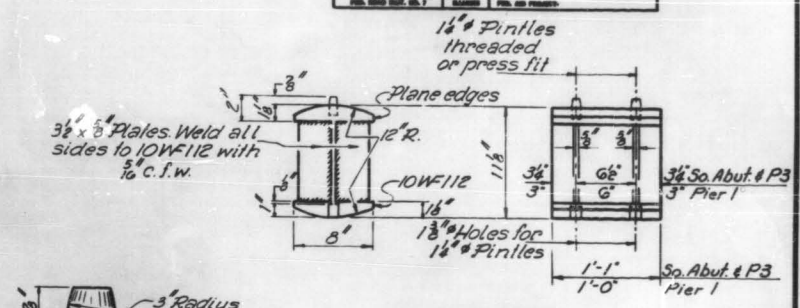

**ROCKER**

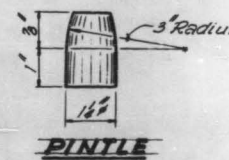

**PINTLE**

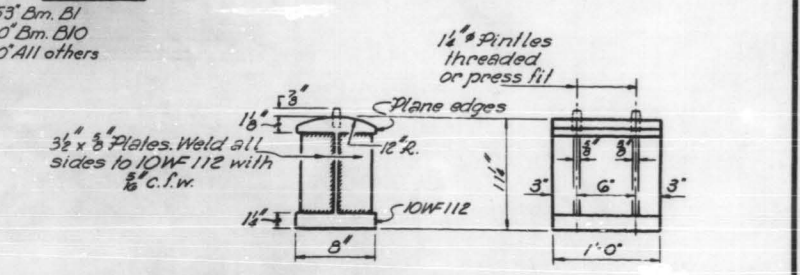

**BOLSTER**

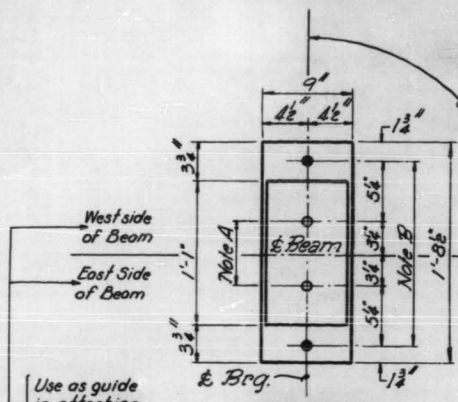

**PLAN**

**SO. BRG. PIER 3**

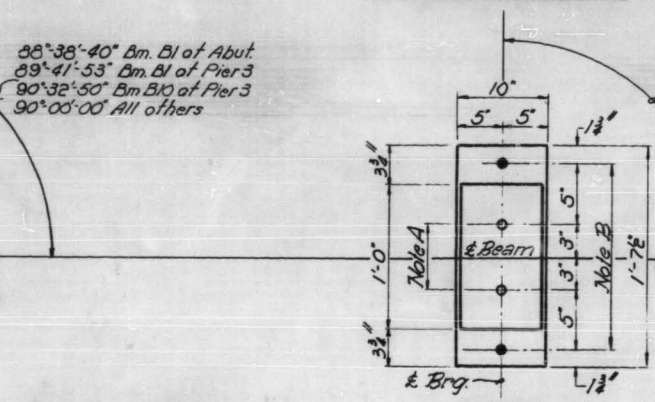

**PLAN**

**PIER 1**

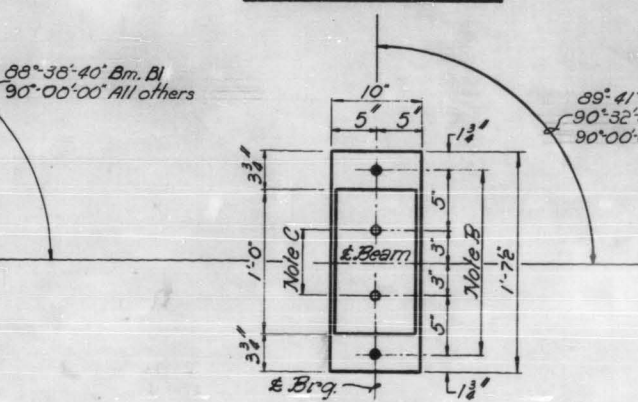

**PLAN**

**PIER 2**

**Note A**  
1 1/2" Holes 1" deep in top flange for pinholes. Thread or press fit pinholes into bottom flange.

**Note B**  
1 1/2" Holes for 1 1/2" anchor bolts. 2 1/2" x 2 1/2" x 1/8" R. Washer under rivet.

**Note C**  
1 1/2" Holes 1" deep in top flange only for 1 1/2" pinholes.

**BEARING ASSEMBLY DETAILS**

**SHIM THICKNESS "t"**

So. Brg. Pier 3 - Bm. B1 - 1 1/8"
Bm. B2 - 5/8"
Bm. B3 - 1 1/8"
Bm. B4 - 1 1/8"
Bm. B5 - 1/2"
Bm. B9 - 1/2"
Bm. B10 - 1/2"

**NOTES ON SETTING OF ANCHOR BOLTS AT EXPANSION BRGS**

- a) D\*\* - (Side of brg away from fixed brg.)  
D\*\* = 5" per each 100' increment of expansion for every 15° fall from temp. of 50°F
- b) D\*\* - (Side of brg. toward fixed brg.)  
D\*\* = 5" per each 100' increment of expansion for every 15° rise from temp. of 50°F
- b) After beams have been erected and dimensions (D or D\*\*) determined anchor bolts shall be placed in drilled holes and grouted.

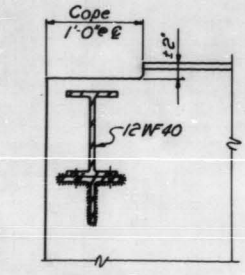

**ELEVATION**

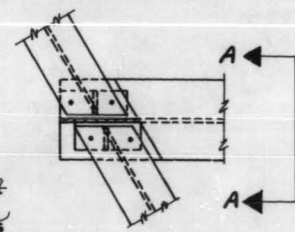

**PLAN**

**DIAPHRAGM Dp1-Dp2**

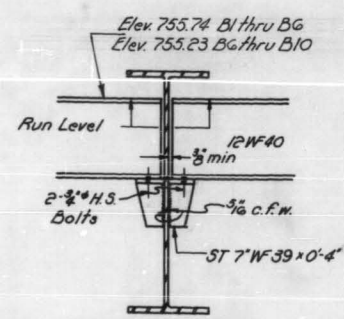

**SECTION A-A**  
For So. Brg. Pier 3 Only

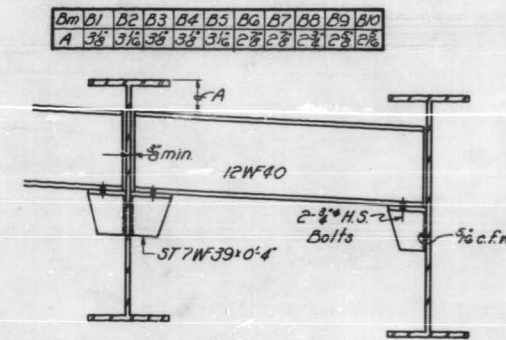

**SECTION A-A**  
For So. Abut. Only

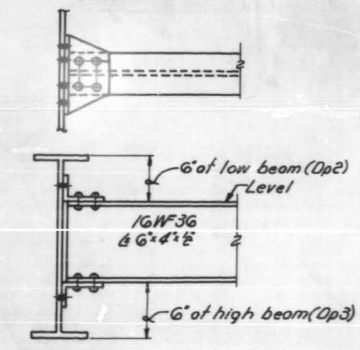

**DIAPHRAGM Dp2 & Dp3**

Work this sheet with preceding sheet.

DESIGNED	James Wang
CHECKED	Toma Kozan
DRAWN	W.E. Dickerson
CHECKED	G.R.

DATE	JUNE 16 1966
EXAMINED	W.E. Dickerson
APPROVED	[Signature]

**BRGS & DIAPH - UNIT B**  
S.B.I. ROUTE 53  
SEC. 531-2-VHB  
COOK COUNTY  
STATION 270+71.7



STATE OF ILLINOIS  
DEPARTMENT OF PUBLIC WORKS & BUILDINGS  
DIVISION OF HIGHWAYS

ROUTE NO.	SECTION	COUNTY	TOTAL SHEETS	SHEET NO.
S. I. 53	531-2-VHB	COOK	67	18
FED. ROAD DIST. NO. 7		ILLINOIS	FED. AID PROJECT	

60 SHEETS

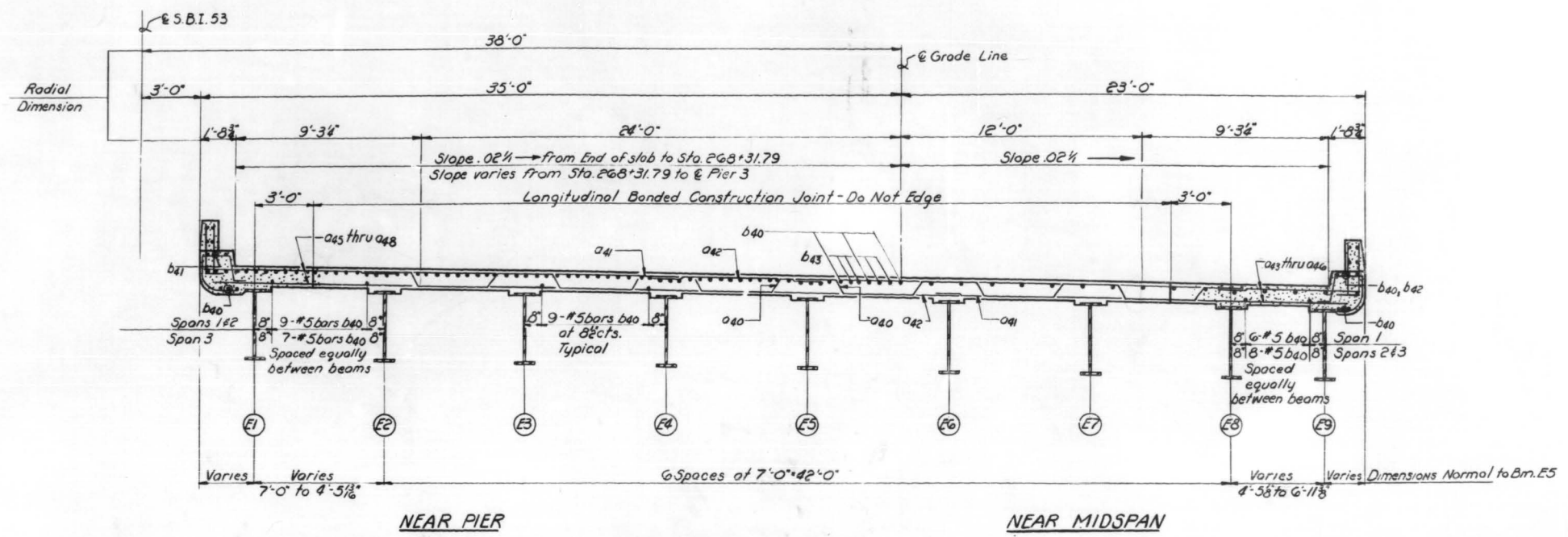

CROSS SECTION

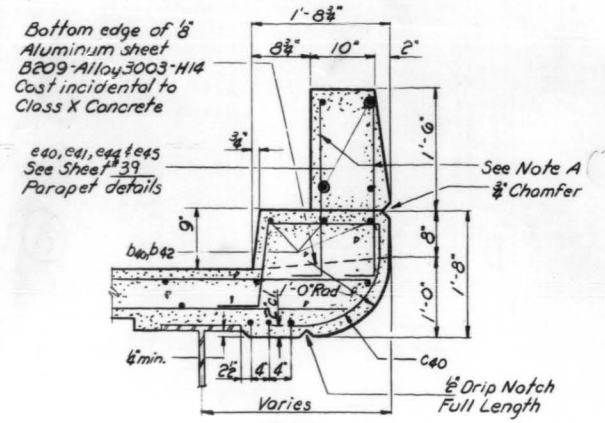

CURB DETAIL

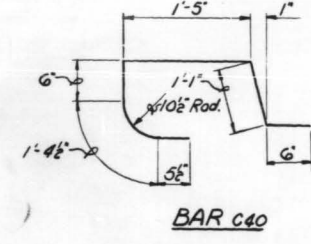

BAR C40

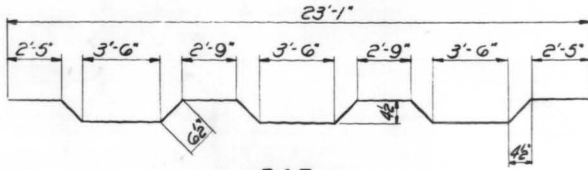

BAR a40

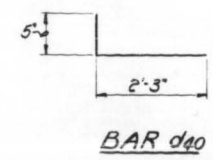

BAR d40

BILL OF MATERIAL

Bar	No	Size	Length	Shape
a40	290	#6	24'-1"	~
a41	380	#6	23'-0"	~
a42	380	#6	37'-0"	~
a43	134	#6	7'-9"	~
a44	52	#6	8'-4"	~
a45	104	#6	8'-8"	~
a46	104	#6	9'-6"	~
a47	134	#6	9'-10"	~
a48	52	#6	9'-2"	~
b40	828	#5	27'-6"	~
b41	24	#5	10'-6"	~
b42	12	#5	30'-6"	~
b43	152	#6	23'-6"	~
c40	336	#5	5'-4"	~
d40	966	#5	2'-8"	~
*Reinforcement Bars			Lbs.	88,330
**Structural Steel			Lbs.	350,090
Class X Concrete			Cu Yds.	328.5

Work this sheet with following sheet

\*\*Structural Steel Quantity includes the following  
1.) Bearing Assemblies, including lead plates and anchor bolts. Est. Wt. 10,960 lbs.  
2.) Sliding plate Expansion Device - includes all material attached (directly or indirectly) to diaphragms of the unit and to the abut. Est. Wt. 13,190 lbs.  
\*Reinforcement Bars quantity includes a series bars in parapet.

**SUPERSTRUCTURE-UNITE**  
S.B.I. ROUTE 53  
SEC. 531-2-VHB  
COOK COUNTY  
STATION 270+71.17

DESIGNED *Lobby (J. Storn)*  
CHECKED *James Warrney*  
DRAWN *W.E. Dickerson*  
CHECKED *JJW*

EXAMINED *H.G. Beeman*  
PASSED *Chucky*  
APPROVED *[Signature]*

JUNE 16 1964





STATE OF ILLINOIS  
DEPARTMENT OF PUBLIC WORKS & BUILDINGS  
DIVISION OF HIGHWAYS

ROUTE NO.	SECTION	COUNTY	TOTAL SHEETS	SHEET NO.	SHEET NO. 14
S. B. I. 53	531-2-VHB	COOK	67	19	60 SHEETS
P. A. 61					
FED. ROAD DIST. NO. 7	ILLINOIS	FED. AID PROJECT			

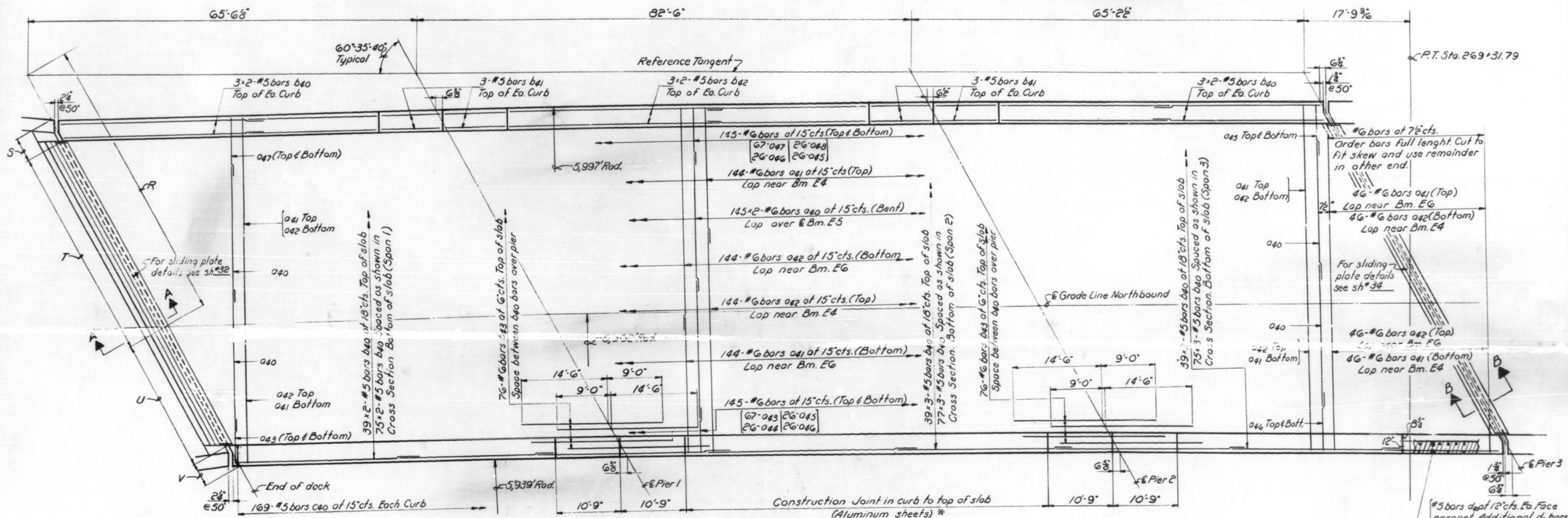
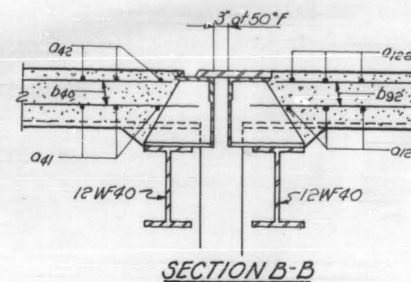

PLAN

NOTE:  
Bars indicated thus 20x3 #5 efc. indicates 20 lines of bars with 3 lengths per line. Lap all a series bars min. of 2'-0". Lap all b series bars min. of 20 diameters.  
\* Aluminum sheeps to be placed normal to water table.

Location	R	S	T	U	V
End of deck	47'-9"	1'-11 1/2"	37'-5 3/8"	23'-11 3/8"	1'-11 3/8"
Center Pier 1	45'-7 1/2"	1'-11 1/2"	37'-8"	24'-14"	1'-11 1/2"
Center Pier 2	43'-11 1/2"	1'-11 1/2"	37'-11 1/2"	24'-3 1/2"	1'-11 1/2"
Center Pier 3	43'-7 1/2"	1'-11 1/2"	38'-2"	24'-5"	1'-11 1/2"

Hatched area to be poured after superstructure forms have been removed. Quantity of Class X Concrete included with superstructure

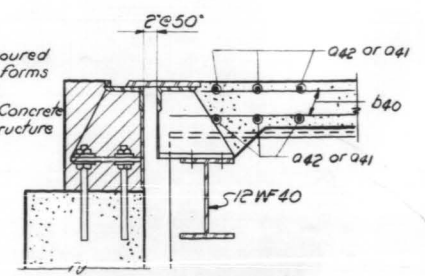

SECTION A-A

Work this sheet with preceding sheet

DESIGNED *Bobby Chilton*  
CHECKED *James Hanning*  
DRAWN *W.E. Dickerson*  
CHECKED *J.W.*

EXAMINED *H.G. Baumann*  
PASSED *Cherry*  
APPROVED *[Signature]*  
CHIEF HIGHWAY ENGINEER

JUNE 16 1964

**SUPERSTRUCTURE-UNIT E**  
S. B. I. ROUTE 53  
SEC. 531-2-VHB  
COOK COUNTY  
STATION 270+71.17





STATE OF ILLINOIS  
DEPARTMENT OF PUBLIC WORKS & BUILDINGS  
DIVISION OF HIGHWAYS

ROUTE NO.	SECTION	COUNTY	TOTAL SHEETS	SHEET NO.
53	531-2	COOK	67	20
61	VHB			

SHEET NO. 15  
60 SHEETS

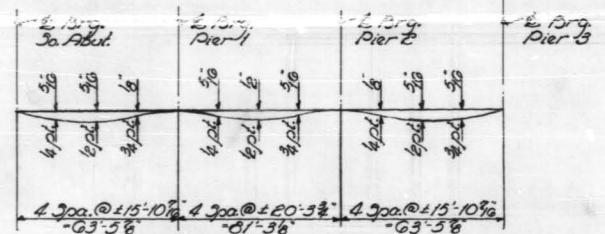
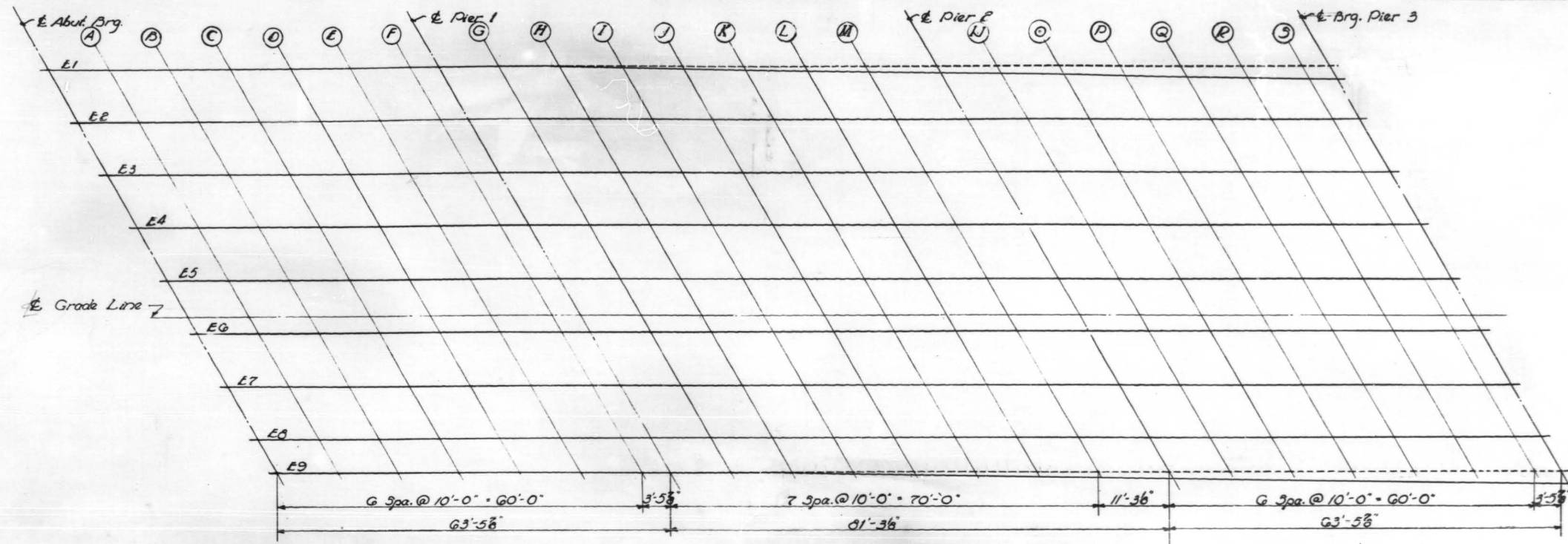

Span 1 Span 2 Span 3  
DEAD LOAD DEFLECTION DIAGRAM

(Includes weight of concrete only)  
Note: The above deflections are not to be used in the field if the Engineer is working from the grade elevations adjusted for dead load deflections

Beam	Station	Offset	Theoretical Grade Elevations	Theoretical Grade Elevations Adjusted For Dead Load Deflection
E Abut.	26706.752	- 11.052	756.651	756.651
A	26716.760	- 12.963	756.709	756.725
B	26726.768	- 12.892	756.765	756.790
C	26736.776	- 12.877	756.818	756.845
D	26746.785	- 12.798	756.870	756.888
E	26756.794	- 12.777	756.919	756.927
F	26766.802	- 12.772	756.966	756.968
E Pier 1	26770.297	- 12.774	756.982	756.982
G	26780.304	- 12.791	757.026	757.039
H	26790.318	- 12.796	757.068	757.091
I	26800.328	- 12.650	757.103	757.138
J	26810.338	- 12.519	757.137	757.180
K	26820.347	- 12.405	757.169	757.209
L	26830.350	- 12.309	757.199	757.225
M	26840.356	- 12.230	757.217	757.241
E Pier 2	26852.357	- 12.161	757.222	757.222
N	26862.364	- 12.119	757.220	757.220
O	26872.370	- 12.093	757.215	757.215
P	26882.377	- 12.084	756.989	757.013
Q	26892.384	- 12.092	756.940	756.966
R	26902.388	- 12.118	756.888	756.908
S	26912.397	- 12.159	756.834	756.840
E Brg.-P3	26916.531	- 12.173	756.814	756.814

Beam	Station	Offset	Theoretical Grade Elevations	Theoretical Grade Elevations Adjusted For Dead Load Deflection
E Abut. Brg.	26734.688	20.580	755.739	755.739
A	26744.787	20.622	755.791	755.806
B	26754.886	20.647	755.841	755.864
C	26764.984	20.655	755.889	755.915
D	26775.083	20.646	755.935	755.952
E	26785.182	20.620	755.978	755.987
F	26795.280	20.578	756.019	756.021
E Pier 1	26798.804	20.559	756.031	756.031
G	26808.902	20.494	756.071	756.084
H	26819.017	20.448	756.106	756.132
I	26829.223	20.541	756.137	756.171
J	26839.430	20.624	756.165	756.207
K	26849.637	20.690	756.190	756.225
L	26859.845	20.738	756.214	756.241
M	26870.051	20.769	756.235	756.249
E Pier 2	26881.555	20.783	756.246	756.246
N	26891.752	20.777	756.272	756.278
O	26901.959	20.752	756.286	756.300
P	26912.167	20.713	756.297	756.322
Q	26922.374	20.658	756.308	756.333
R	26932.581	20.584	756.315	756.336
S	26942.787	20.492	756.319	756.325
E Brg.-P3	26946.348	20.437	756.321	756.321

Elevations shown are along E all beams.

SLAB ELEVATIONS - UNIT E  
S.B.I. ROUTE 53  
SEC. 531-2 - VHB  
COOK COUNTY  
STA. 270 + 71.17

DESIGNED *Leon Manning*  
CHECKED *Thomas R. Mancini*  
DRAWN *Jacobs*  
CHECKED *B.C. GR*

EXAMINED *H.E. Baumann*  
PASSED *[Signature]*  
APPROVED *[Signature]*

JUNE 16 1964



STATE OF ILLINOIS  
DEPARTMENT OF PUBLIC WORKS & BUILDINGS  
DIVISION OF HIGHWAYS

*E. Brg. Abut.*

Beam	Station	Offset	Theoretical Grade Elevations	Theoretical Grade Elevations Adjusted For Dead Load Deflection
LE	26710.384	26.018	756.533	756.533
S	26714.024	18.982	756.414	756.414
A	26717.673	11.956	756.294	756.294
S	26721.330	4.928	756.175	756.175
G	26724.996	2.091	756.055	756.055
P	26728.671	5.124	755.936	755.936
EO	26732.354	16.141	755.815	755.815
LE	26720.403	25.934	756.590	756.605
S	26724.005	18.909	756.470	756.485
A	26727.716	11.883	756.350	756.365
S	26731.385	4.864	756.230	756.245
G	26735.063	2.154	756.109	756.124
P	26738.750	9.172	755.989	755.994
EO	26742.445	16.188	755.868	755.883
LE	26730.423	25.879	756.645	756.669
S	26734.067	18.854	756.524	756.549
A	26737.780	11.828	756.404	756.428
S	26741.441	4.811	756.283	756.307
G	26745.131	2.138	756.161	756.186
P	26748.829	9.207	756.040	756.065
EO	26752.536	16.219	755.918	755.943
LE	26740.444	25.821	756.897	756.924
S	26744.119	18.807	756.776	756.802
A	26747.804	11.793	756.655	756.681
S	26751.497	4.780	756.534	756.560
G	26755.198	2.020	756.413	756.439
P	26758.909	9.055	756.292	756.318
EO	26762.628	16.227	756.171	756.197
LE	26750.464	25.788	756.748	756.766
S	26754.151	18.781	756.626	756.644
A	26757.847	11.775	756.504	756.522
S	26761.552	4.772	756.382	756.399
G	26765.266	2.225	756.261	756.277
P	26768.988	9.225	756.140	756.155
EO	26772.719	16.222	756.018	756.031
LE	26760.484	25.773	756.797	756.805
S	26764.183	18.771	756.674	756.682
A	26767.891	11.772	756.551	756.559
S	26771.608	4.775	756.428	756.435
G	26775.33	2.218	756.304	756.313
P	26779.067	9.211	756.181	756.189
EO	26782.810	16.201	756.057	756.065
LE	26770.505	25.774	756.843	756.845
S	26774.216	18.773	756.719	756.722
A	26777.935	11.780	756.596	756.598
S	26781.664	4.795	756.472	756.474
G	26785.401	2.192	756.347	756.350
P	26789.146	9.179	756.223	756.225
EO	26792.901	16.162	756.098	756.100

*E. Pier 1*

Beam	Station	Offset	Theoretical Grade Elevations	Theoretical Grade Elevations Adjusted For Dead Load Deflection
LE	26774.001	25.778	756.858	756.858
S	26777.718	18.785	756.735	756.735
A	26781.440	11.794	756.611	756.611
S	26785.173	4.806	756.487	756.487
G	26788.914	2.179	756.362	756.362
P	26792.664	9.163	756.237	756.237
EO	26796.422	16.145	756.112	756.112
LE	26784.022	25.802	756.902	756.914
S	26787.748	18.815	756.777	756.790
A	26791.484	11.831	756.653	756.665
S	26795.228	4.848	756.528	756.540
G	26798.981	2.131	756.402	756.415
P	28802.743	9.109	756.277	756.290
EO	28806.513	16.084	756.151	756.164
LE	26794.042	25.843	756.943	756.968
S	26797.780	18.862	756.818	756.843
A	28801.527	11.883	756.692	756.718
S	28805.283	4.907	756.566	756.592
G	28809.048	2.065	756.440	756.466
P	28812.822	9.031	756.314	756.340
EO	28816.604	16.006	756.187	756.213
LE	28804.062	25.905	756.982	757.016
S	28807.812	18.925	756.856	756.890
A	28811.571	11.953	756.730	756.764
S	28815.338	4.983	756.603	756.637
G	28819.115	1.983	756.476	756.510
P	28822.900	8.940	756.349	756.383
EO	28826.694	15.911	756.222	756.256
LE	26814.082	25.973	757.019	757.061
S	26817.844	18.006	756.892	756.934
A	26821.614	12.039	756.765	756.807
S	26825.393	5.076	756.637	756.680
G	26829.181	1.884	756.510	756.552
P	26832.978	8.843	756.382	756.424
EO	26836.784	15.800	756.254	756.296
LE	26824.102	26.064	757.053	757.088
S	26827.875	19.102	756.926	756.961
A	26831.657	12.142	756.798	756.833
S	26835.448	5.185	756.669	756.701
G	26839.247	1.769	756.541	756.576
P	26843.056	8.721	756.413	756.448
EO	26846.874	15.671	756.284	756.319
LE	26834.121	26.171	757.073	757.100
S	26837.906	19.215	756.944	756.961
A	26841.699	12.262	756.804	756.831
S	26845.502	5.311	756.685	756.712
G	26849.313	1.636	756.571	756.597
P	26853.133	8.582	756.441	756.468
EO	26856.963	15.525	756.311	756.338
LE	26844.140	26.225	757.051	757.065
S	26847.936	19.246	756.924	756.939
A	26851.741	12.299	756.808	756.822
S	26855.555	5.454	756.702	756.716
G	26859.378	1.487	756.598	756.612
P	26863.210	8.427	756.467	756.482
EO	26867.051	15.364	756.337	756.351

*E. Pier 2*

Beam	Station	Offset	Theoretical Grade Elevations	Theoretical Grade Elevations Adjusted For Dead Load Deflection
LE	26805.421	26.405	757.022	757.022
S	26809.230	19.512	756.910	756.910
A	26813.049	12.573	756.808	756.808
S	26816.876	5.635	756.717	756.717
G	26820.712	1.299	756.625	756.625
P	26824.557	8.231	756.494	756.494
EO	26828.411	15.161	756.363	756.363
LE	26805.439	26.614	756.994	757.000
S	26809.260	19.678	756.895	756.901
A	26813.089	12.745	756.806	756.812
S	26816.928	5.814	756.727	756.733
G	26820.775	1.114	756.648	756.654
P	26824.632	8.040	756.516	756.522
EO	26828.498	14.964	756.383	756.390
LE	26805.456	26.790	756.962	756.977
S	26809.288	19.861	756.875	756.890
A	26813.130	12.933	756.800	756.814
S	26816.980	6.009	756.734	756.748
G	26820.839	1.912	756.668	756.682
P	26824.701	7.832	756.535	756.549
EO	26828.584	14.749	756.402	756.416
LE	26805.473	26.983	756.928	756.952
S	26809.317	20.060	756.854	756.879
A	26813.169	13.139	756.791	756.816
S	26817.031	6.221	756.738	756.763
G	26820.902	1.594	756.686	756.710
P	26824.782	7.607	756.552	756.577
EO	26828.670	14.518	756.418	756.443
LE	26805.488	27.192	756.890	756.915
S	26809.344	20.275	756.830	756.855
A	26813.208	13.361	756.779	756.804
S	26817.082	6.450	756.739	756.764
G	26820.964	1.459	756.702	756.727
P	26824.855	7.365	756.567	756.592
EO	26828.755	14.270	756.432	756.458
LE	26805.504	27.418	756.849	756.870
S	26809.371	20.508	756.801	756.822
A	26813.247	13.600	756.754	756.784
S	26817.131	6.695	756.736	756.757
G	26821.025	1.207	756.715	756.736
P	26824.928	7.107	756.580	756.601
EO	26828.839	14.005	756.444	756.465
LE	26815.519	27.561	756.805	756.811
S	26819.397	20.757	756.770	756.775
A	26823.294	13.856	756.745	756.750
S	26827.180	6.957	756.730	756.735
G	26831.085	1.061	756.726	756.731
P	26834.999	6.832	756.591	756.596
EO	26838.923	13.723	756.454	756.459
LE	26819.013	27.750	756.789	756.789
S	26822.895	20.848	756.758	756.758
A	26826.786	13.949	756.737	756.737
S	26830.686	7.053	756.727	756.727
G	26834.596	1.159	756.727	756.727
P	26838.514	6.732	756.594	756.594
EO	26842.441	13.620	756.457	756.457

*E. Brg. Pier 3*

DESIGNED *Gunn Manning*  
 EXAMINED *W.E. Baumann*  
 CHECKED *Thomas R. Jacobs*  
 PASSED *[Signature]*  
 DRAWN *[Signature]*  
 CHECKED *B.C. G.R.*  
 APPROVED *[Signature]*  
 JUNE 16 1964

SLAB ELEVATIONS - UNIT E  
 S.B.I. ROUTE 53  
 SEC. 531-2-VHB  
 COOK COUNTY  
 STA. 270+71.17





STATE OF ILLINOIS  
DEPARTMENT OF PUBLIC WORKS & BUILDINGS  
DIVISION OF HIGHWAYS

ROUTE NO.	SECTION	COUNTY	TOTAL SHEETS	SHEET NO.	SHEET NO. 17
S. I. 53	531-2	COOK	67	22	60 SHEETS
P.A. 61	-VHB				
FED. ROAD DIST. NO. 7	ILLINOIS	FED. AID PROJECT			

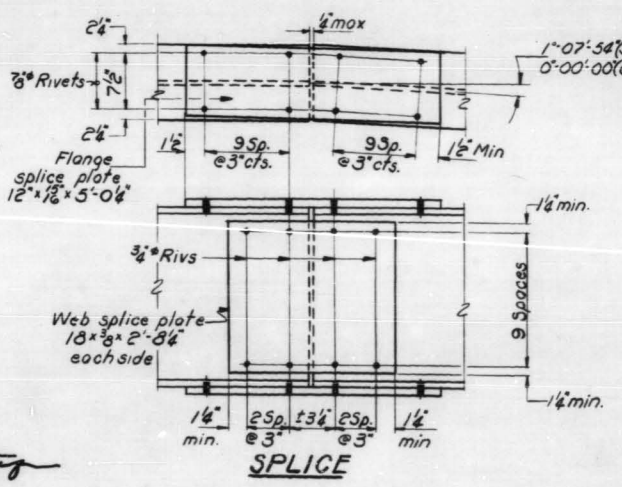
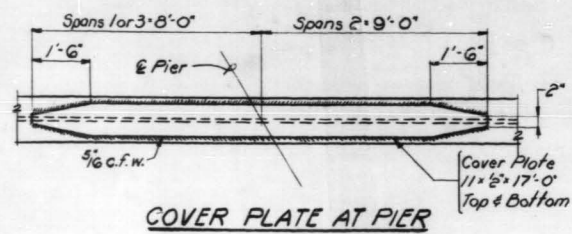
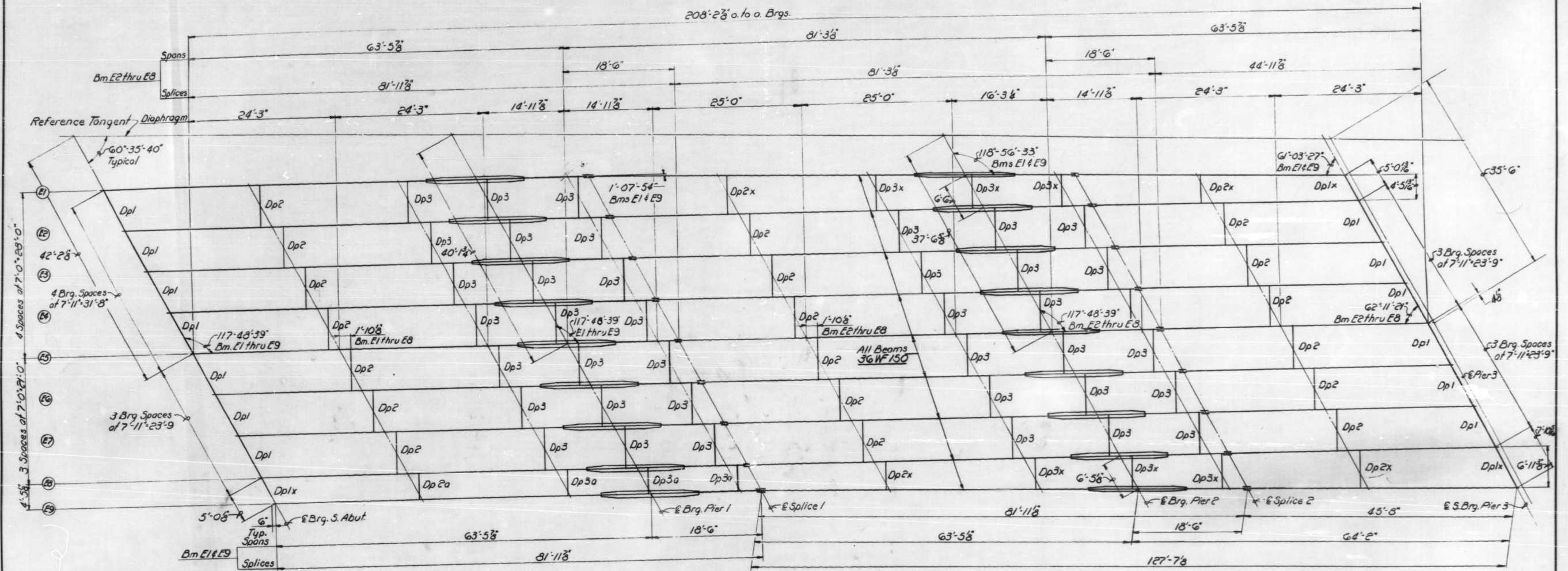

STRUCTURAL STEEL LAYOUT

TOP OF BEAM ELEVATION

Beam	So. Abut. Brg.	Pier 1	Splice 1	Pier 2	Splice 2	So. Brg. Pier 3
E1	756.08	756.33	756.40	756.40	756.40	756.10
E2	755.97	756.22	756.29	756.29	756.29	755.93
E3	755.75	756.00	756.07	756.20	756.24	756.19
E4	755.67	755.92	756.00	756.13	756.17	756.12
E5	755.61	755.86	755.93	756.06	756.10	756.16
E6	755.49	755.74	755.81	755.94	755.98	756.05
E7	755.36	755.61	755.69	755.82	755.86	755.92
E8	755.24	755.49	755.56	755.69	755.73	755.79
E9	755.16	755.41	755.48	755.61	755.65	755.71

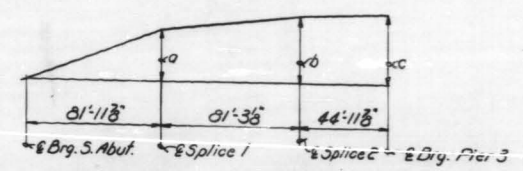

FABRICATION DIAGRAM

Beam	a	b	c
1 & 2	3 3/8"	3 3/8"	4"
3 & 4	3 3/8"	5 1/8"	5 3/8"
5 thru 9	3 3/8"	5 1/8"	6 1/8"

DESIGNED *James G. Wadsworth*  
 EXAMINED *H. P. ...* JUNE 16 1964  
 CHECKED *Tama ...*  
 DRAWN *B.C. ...*  
 CHECKED *C.R. ...*

STRUCTURAL STEEL UNIT E  
 S.B.I. ROUTE 53  
 SEC. 531-2-VHB  
 COOK COUNTY  
 STATION 270+71.17



STATE OF ILLINOIS  
DEPARTMENT OF PUBLIC WORKS & BUILDINGS  
DIVISION OF HIGHWAYS

NOTE NO.	SECTION	COUNTY	SHEET NO.	SHEET NO.
1	53	COOK	67	23
SHEET NO. 18		60 SHEETS		

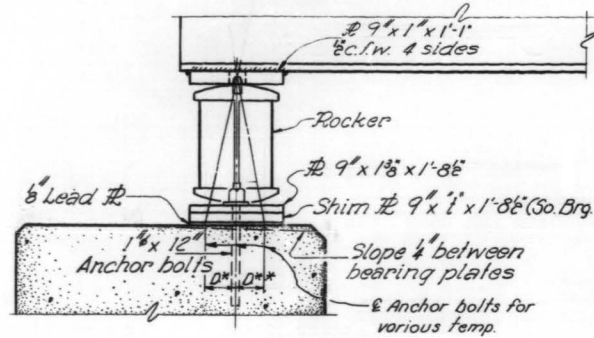

**ELEVATION**

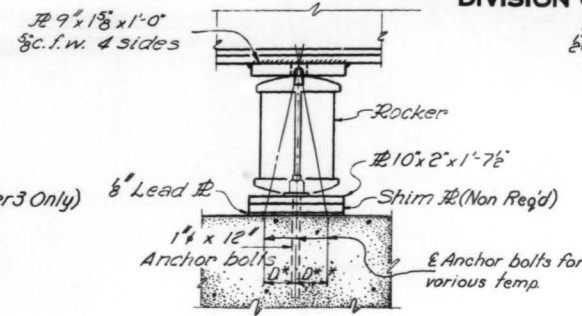

**ELEVATION**

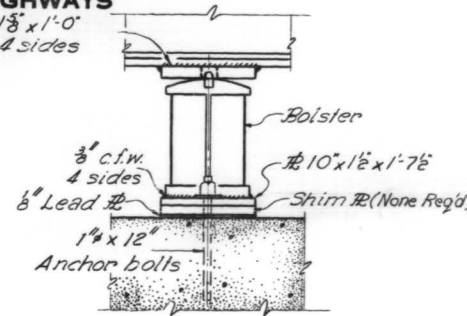

**ELEVATION**

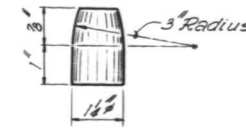

**PINLE**

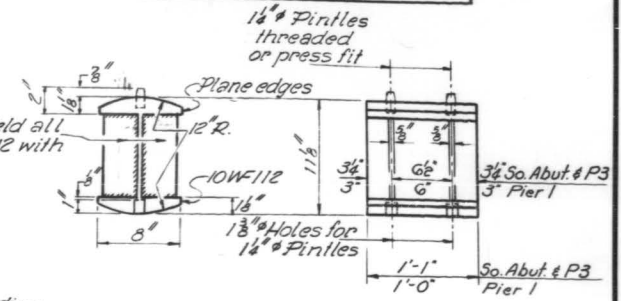

**ROCKER**

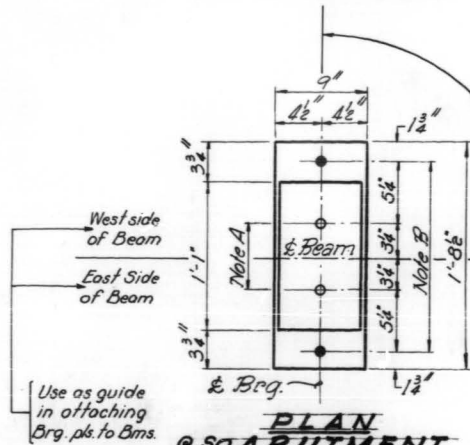

**PLAN @ SO. ABUTMENT & SO. BRG. PIER 3**

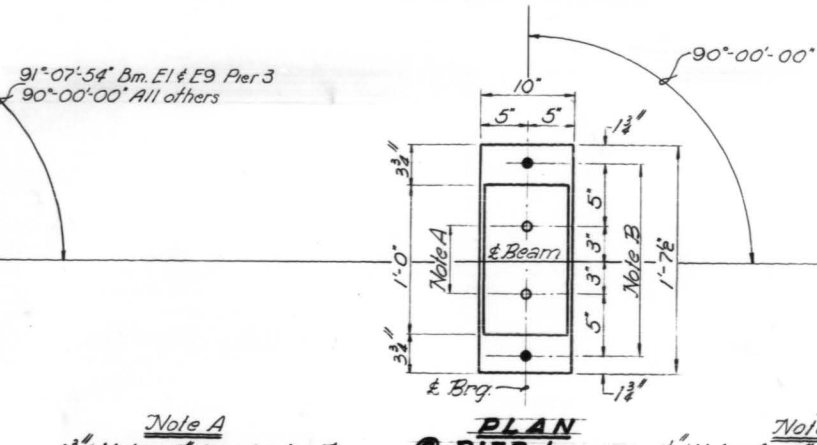

**PLAN @ PIER 1**

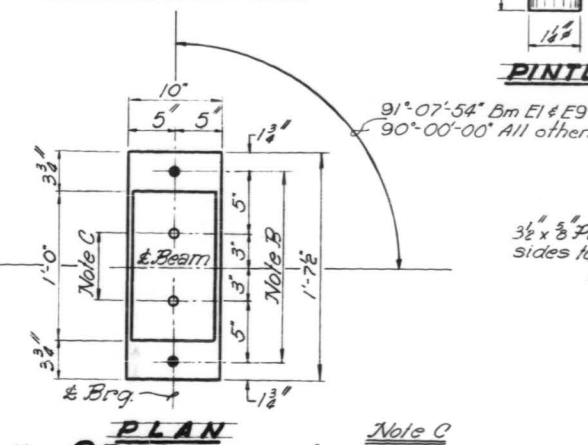

**PLAN @ PIER 2**

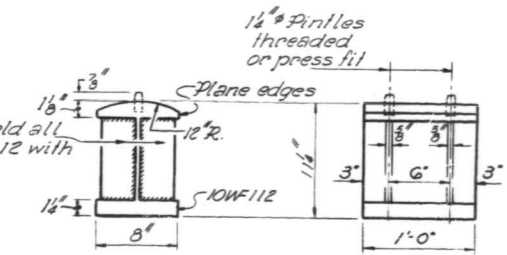

**BOLSTER**

**SHIM THICKNESS "t"**

So. Brg. Pier 3 - Bm. E1-1 3/8"
Bm. E2-3/8"
Bm. E3-2 3/8"
Bm. E4-3/8"
Bm. E5-1 1/2"
Bm. E6-5/8"
Bm. E7-1/2"
Bm. E8-1/2"
Bm. E9-1"

**BEARING ASSEMBLY DETAILS**

**NOTES ON SETTING OF ANCHOR BOLTS AT EXPANSION BRGS**

- a) D\*\* (Side of brg. away from fixed brg.)  
D\*\* = 5/8" per each 100' increment of expansion for every 15° fall from temp. of 50°F
- b) D\*\*\* (Side of brg. toward fixed brg.)  
D\*\*\* = 5/8" per each 100' increment of expansion for every 15° rise from temp. of 50°F
- b) After beams have been erected and dimensions (D\* or D\*\*) determined anchor bolts shall be placed in drilled holes and grouted.

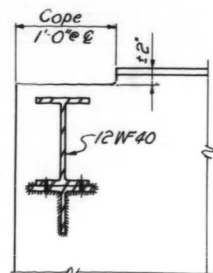

**ELEVATION**

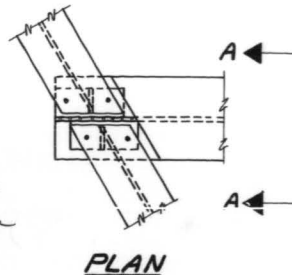

**PLAN**

**DIAPHRAGM Dp1-Dp3**

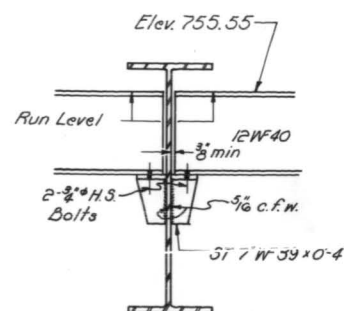

**SECTION A-A**  
For So. Brg. Pier 3 Only

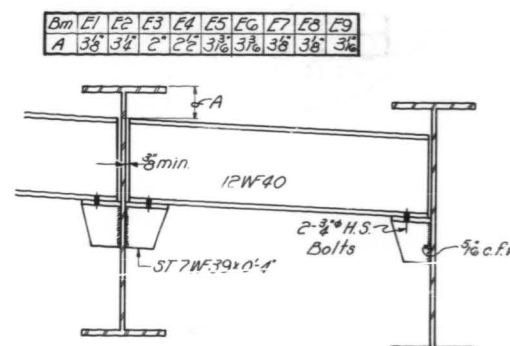

**SECTION A-A**  
For So. Abutment Only

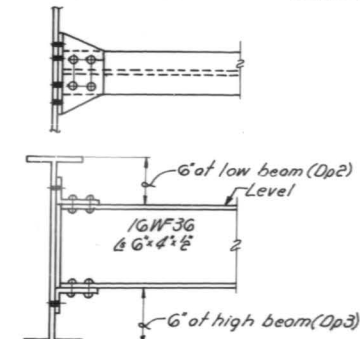

**DIAPHRAGM Dp2 & Dp3**

Work this sheet with preceding sheet.

**BRGS. & DIAPH. - UNITE**  
S.B.I. ROUTE 53  
SEC. 531-2-VHB  
COOK COUNTY  
STATION 270+71.7

DESIGNED	JUNE 16 1964
CHECKED	W.E. Dickerson
DRAWN	S.C. Muller
CHECKED	J.W.

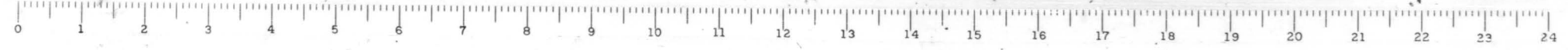



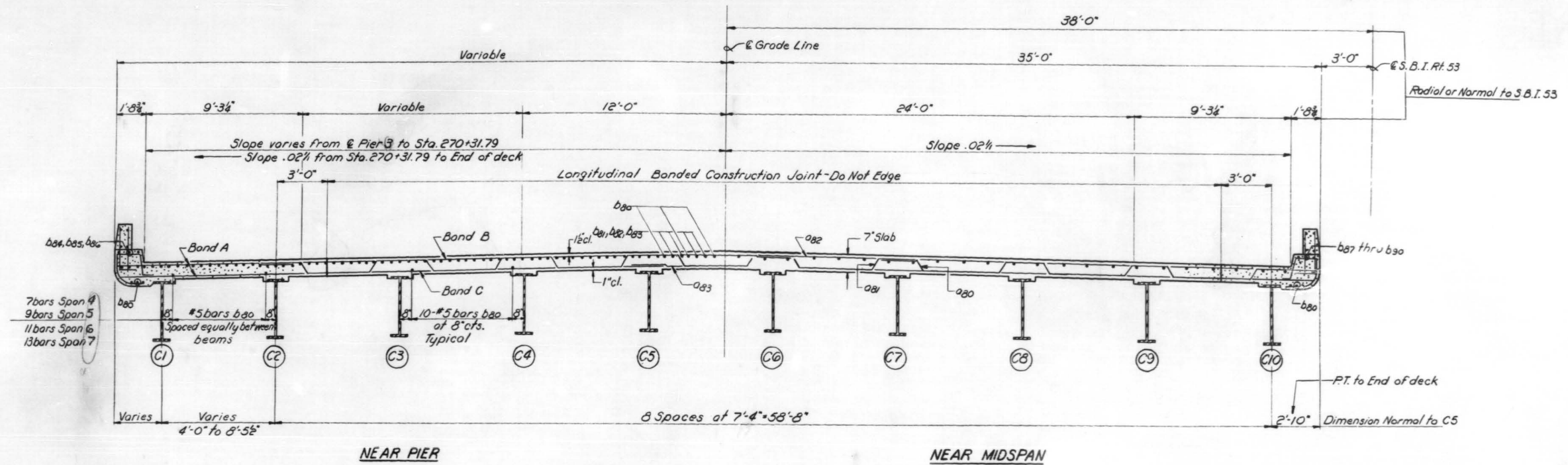

CROSS SECTION

BILL OF MATERIAL

Bar	No	Size	Length	Shape	Bar	No	Size	Length	Shape
a80	210	#6	26'-7"	U	b80	1592	#5	28'-6"	
a81	210	#6	40'-5"	U	b81	96	#6	25'-6"	
a82	272	#6	33'-0"	U	b82	96	#6	25'-0"	
a83	272	#6	40'-4"	U	b83	96	#6	24'-6"	
a84	56	#7	12'-0"	U	b84	12	#5	11'-9"	
a85	54	#7	11'-6"	U	b85	12	#5	10'-6"	
a87	52	#6	10'-8"	U	b86	12	#5	11'-3"	
a88	52	#6	10'-2"	U	b87	12	#5	26'-0"	
a89	52	#6	9'-8"	U	b88	12	#5	30'-6"	
a90	52	#6	9'-2"	U	b89	12	#5	27'-6"	
a91	104	#6	8'-8"	U	b90	18	#5	23'-6"	
a92	90	#6	33'-8"	U					
a93	26	#6	33'-2"	U					
a94	26	#6	32'-8"	U	c80	240	#5	5'-8"	
a95	26	#6	32'-2"	U	c81	241	#5	6'-1"	
a96	26	#6	31'-8"	U					
a97	26	#6	31'-2"	U					
a98	52	#6	30'-8"	U	d80	1372	#5	2'-8"	
a99	90	#6	41'-0"	U					
a100	26	#6	40'-6"	U					
a101	26	#6	40'-0"	U					
a102	26	#6	39'-6"	U					
a103	26	#6	39'-0"	U					
a104	26	#6	38'-6"	U					
a105	52	#6	38'-0"	U					
					*Reinforcement Bars		Lbs.	156,920	
					*Structural Steel		Lbs.	662,730	
					Class X Concrete		Cu. Yds.	566.8	

Work this sheet with following sheet

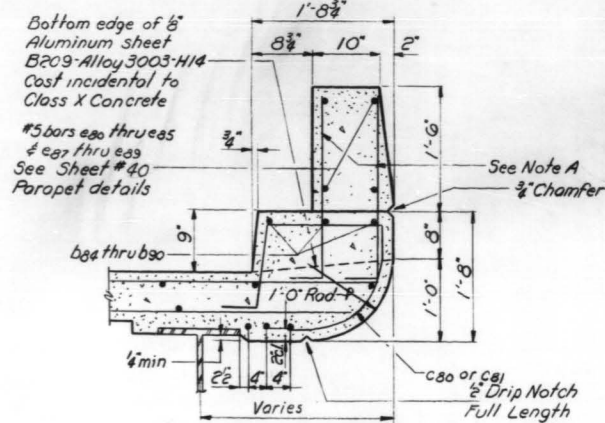

CURB DETAIL

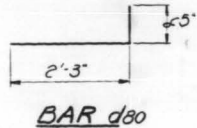
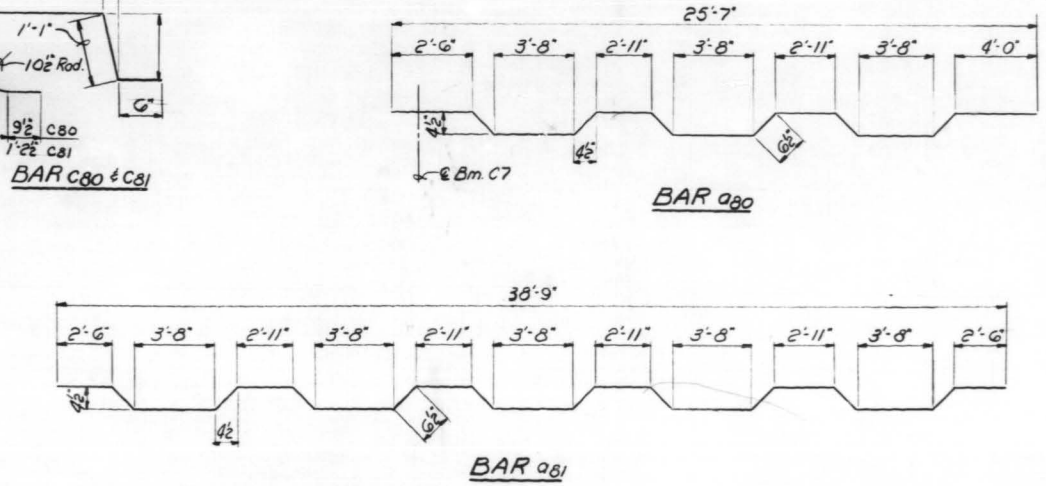
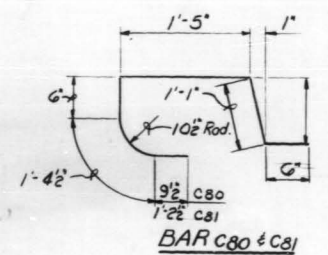

\* Structural Steel quantity includes the following  
1) Bearing Assemblies including lead plates and anchor bolts. Est. Wt. 15,210 Lbs.  
2) Sliding plate Expansion Device - includes all material attached (directly or indirectly) to diaphragms of the unit and to the abutment. Est. Wt. 18,040 Lbs.  
\* Reinforcement Bars quantity includes a series bars in parapet.

**SUPERSTRUCTURE-UNIT C**  
S. B. I. ROUTE 53  
SEC. 531-2-VHB  
COOK COUNTY  
STATION 270+71.7

DESIGNED: *Bobby Chilton*  
CHECKED: *James J. Wawering*  
DRAWN: *W.F. Dickerson*  
CHECKED: *JW*

EXAMINED: *W.E. Baumann*  
PASSED: *[Signature]*  
APPROVED: *[Signature]*  
JUNE 16 1964





STATE OF ILLINOIS  
DEPARTMENT OF PUBLIC WORKS & BUILDINGS  
DIVISION OF HIGHWAYS

ROUTE NO.	SECTION	COUNTY	TOTAL SHEETS	SHEET NO.	SHEET NO. 20
S.B.I. 53	531-2	COOK	67	25	60 SHEETS
P.A. 61	-VHB				
FED. ROAD DIST. NO. 1	ILLINOIS	FED. AID PROJECT			

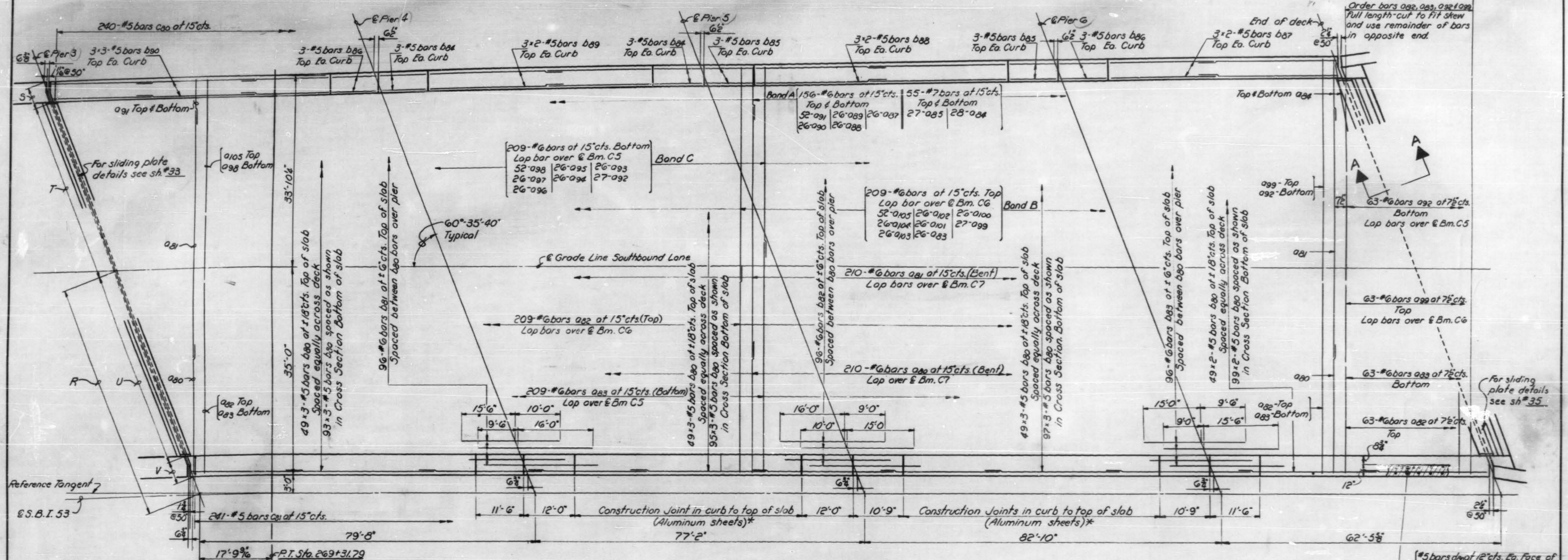

PLAN

NOTE:  
Bars indicated thus 20x3 #5 etc.  
indicates 20 lines of bars with  
3 lengths per line. Lap all a series  
bars min. of 2'-0". Lap all b series  
bars min. of 20 diameters.  
\* Aluminum sheets to be placed  
normal to water table.

Location	R	S	T	U	V
€ Pier 3	43'-5 1/2"	1'-11 1/2"	35'-8 3/4"	38'-1"	1'-11 1/2"
€ Pier 4	43'-7 3/8"	1'-11 1/2"	37'-3"	38'-2 1/4"	1'-11 1/2"
€ Pier 5	43'-7 3/8"	1'-11 1/2"	38'-6 3/4"	38'-2 1/4"	1'-11 1/2"
€ Pier 6	43'-7 3/8"	1'-11 1/2"	39'-11 1/2"	38'-2 1/4"	1'-11 1/2"
End of deck	43'-7 3/8"	1'-11 1/2"	41'-0"	38'-2 1/4"	1'-11 1/2"

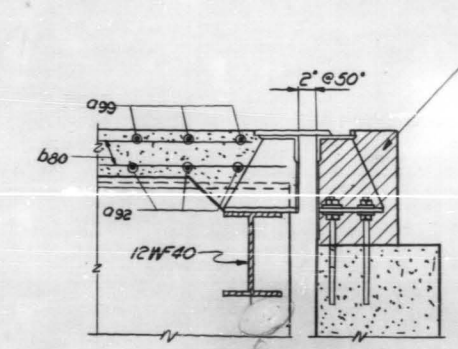

SECTION A-A

Hatched area to be poured  
after superstructure forms  
have been removed.  
Quantity of Class X Concrete  
included with superstructure.

Work this sheet with preceding sheet

DESIGNED *Toddy Chilton*  
CHECKED *James H. Harris*  
DRAWN *W.E. Dickerson*  
CHECKED *JJW*

JUNE 16 1964  
EXAMINED *W.E. Dickerson*  
PASSED *Adams*  
APPROVED *U*  
CHIEF HIGHWAY ENGINEER

SUPERSTRUCTURE-UNIT C  
S.B.I. ROUTE 53  
SEC. 531-2-VHB  
COOK COUNTY  
STATION 270+7.17





STATE OF ILLINOIS  
DEPARTMENT OF PUBLIC WORKS & BUILDINGS  
DIVISION OF HIGHWAYS

ROUTE NO.	SECTION	COUNTY	TOTAL SHEETS	SHEET NO.	SHEET NO. 21
53	531-2	COOK	67	26	60 SHEETS
VHB					

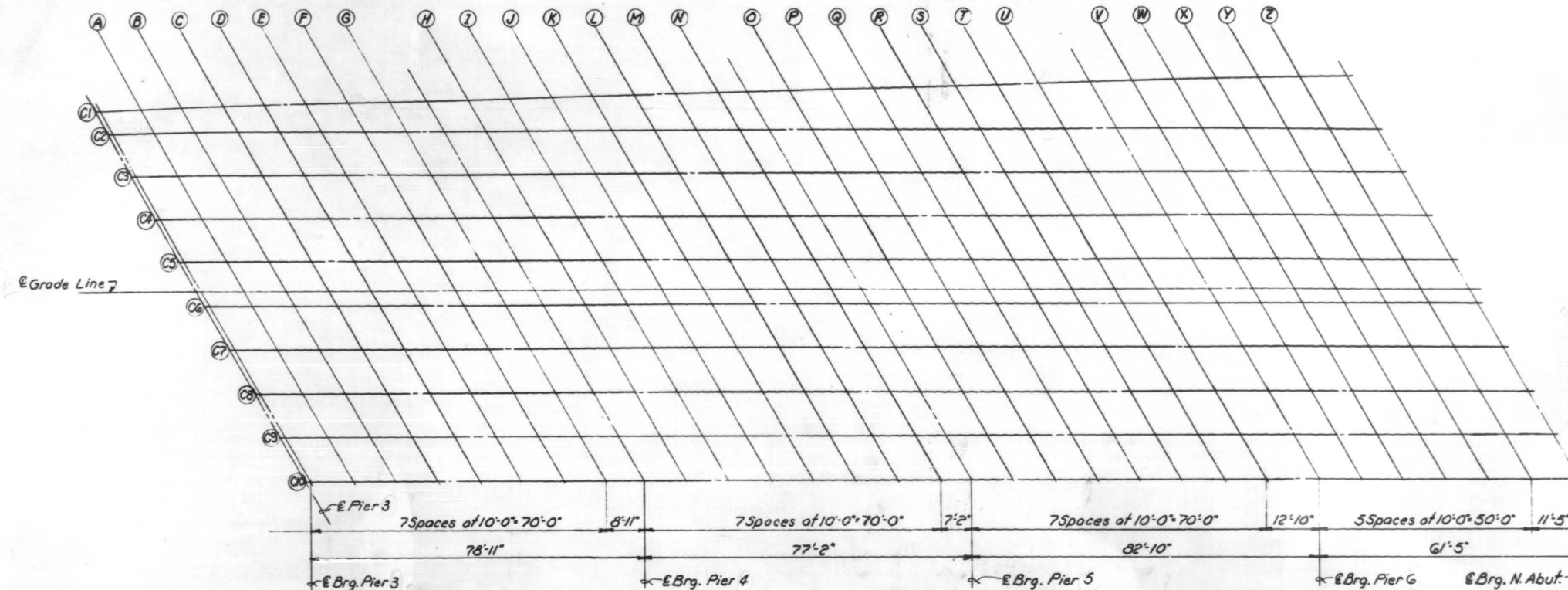

Beam	Station	Offset	Theoretical Grade Elevations	Theoretical Grade Elevations Adjusted For Dead Load Deflection
Br. Pier 3	C10 26911.469	32.132	756.069	756.069
A	C10 26921.459	32.157	756.077	756.110
B	C10 26931.449	32.166	756.082	756.148
C	C10 26941.449	32.166	756.086	756.159
D	C10 26951.449	32.166	756.087	756.166
E	C10 26961.449	32.166	756.085	756.145
F	C10 26971.449	32.166	756.081	756.121
G	C10 26981.449	32.166	756.074	756.093
Pier 4	C10 26990.389	32.166	756.066	756.066
H	C10 27000.389	32.166	756.055	756.048
I	C10 27010.389	32.166	756.041	756.028
J	C10 27020.389	32.166	756.025	756.016
K	C10 27030.389	32.166	756.006	756.000
L	C10 27040.389	32.166	755.985	755.976
M	C10 27050.389	32.166	755.961	755.951
N	C10 27060.389	32.166	755.934	755.930
Br. Pier 5	C10 27067.556	32.166	755.914	755.914
O	C10 27077.556	32.166	755.883	755.896
P	C10 27087.556	32.166	755.850	755.875
Q	C10 27097.556	32.166	755.815	755.850
R	C10 27107.556	32.166	755.776	755.823
S	C10 27117.556	32.166	755.736	755.775
T	C10 27127.556	32.166	755.693	755.721
U	C10 27137.556	32.166	755.647	755.663
Br. Pier 6	C10 27150.389	32.166	755.585	755.585
V	C10 27160.389	32.166	755.533	755.536
W	C10 27170.389	32.166	755.480	755.489
X	C10 27180.389	32.166	755.423	755.444
Y	C10 27190.389	32.166	755.364	755.386
Z	C10 27200.389	32.166	755.303	755.319
Br. N. Abut.	C10 27211.806	32.166	755.230	755.230

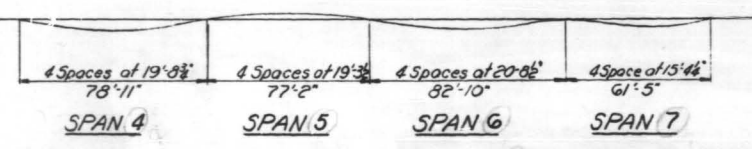

Beam	Span 4			Span 5			Span 6			Span 7		
	1/2	1/4	3/8	1/2	1/4	3/8	1/2	1/4	3/8	1/2	1/4	3/8
C1	1/2	1/4	3/8	1/2	1/4	3/8	1/2	1/4	3/8	1/2	1/4	3/8
C2 thru C9	1/2	1/4	3/8	1/2	1/4	3/8	1/2	1/4	3/8	1/2	1/4	3/8
C10	1/2	1/4	3/8	1/2	1/4	3/8	1/2	1/4	3/8	1/2	1/4	3/8

**DEAD LOAD DEFLECTION DIAGRAM**  
Includes weight of concrete only.

Note: The above deflections are not for use in the field if the Engineer is working from the Theoretical Grade Elevation Adjusted for Dead Load Deflection.

Beam	Station	Offset	Theoretical Grade Elevations	Theoretical Grade Elevations Adjusted For Dead Load Deflection
Br. Pier 3	C1 26876.443	30.752	757.003	757.003
A	C1 26886.329	30.818	756.960	756.988
B	C1 26896.215	30.901	756.914	756.969
C	C1 26906.101	31.000	756.865	756.926
D	C1 26915.987	31.115	756.814	756.879
E	C1 26925.872	31.247	756.760	756.809
F	C1 26936.129	31.379	756.700	756.739
G	C1 26946.127	31.524	756.639	756.657
Br. Pier 4	C1 26954.385	31.645	756.587	756.587
H	C1 26964.382	31.791	756.520	756.513
I	C1 26974.380	31.938	756.451	756.437
J	C1 26984.377	32.085	756.378	756.369
K	C1 26994.375	32.232	756.309	756.296
L	C1 27004.372	32.380	756.223	756.215
M	C1 27014.370	32.529	756.141	756.132
N	C1 27024.367	32.678	756.056	756.052

Beam	Station	Offset	Theoretical Grade Elevations	Theoretical Grade Elevations Adjusted For Dead Load Deflection
Br. Pier 5	C1 27030.389	32.775	755.999	755.999
O	C1 27040.894	32.925	755.968	755.981
P	C1 27050.892	33.075	755.941	755.966
Q	C1 27060.889	33.225	755.912	755.948
R	C1 27070.885	33.376	755.880	755.927
S	C1 27080.884	33.527	755.845	755.884
T	C1 27090.881	33.679	755.808	755.836
U	C1 27100.879	33.831	755.769	755.784
Br. Pier 6	C1 27113.759	34.017	755.717	755.718
V	C1 27123.019	34.170	755.672	755.675
W	C1 27133.016	34.324	755.625	755.634
X	C1 27143.013	34.478	755.575	755.596
Y	C1 27153.011	34.632	755.522	755.544
Z	C1 27163.008	34.787	755.467	755.483
Br. N. Abut.	C1 27173.911	34.957	755.404	755.404

DESIGNED: J.B. Nelson  
 CHECKED: J. Dickerson  
 DRAWN: W.E. Dickerson  
 CHECKED: G.R.  
 EXAMINED: W.E. Baumann  
 PASSED: [Signature]  
 APPROVED: [Signature]  
 JUNE 16 1964

**SLAB ELEVATIONS-UNIT**  
 S.B.I. ROUTE 53  
 SEC. 531-2-VHB  
 COOK COUNTY  
 STATION 270+71.7







STATE OF ILLINOIS  
DEPARTMENT OF PUBLIC WORKS & BUILDINGS  
DIVISION OF HIGHWAYS

ROUTE NO.	SECTION	COUNTY	TOTAL SHEETS	SHEET NO.	SHEET NO.
S. R. 53	531-2	COOK	47	28	60 SHEETS
P.L. 61	VHB				
FED. ROAD DIST. NO. 7	ILLINOIS	FED. AID PROJECT			

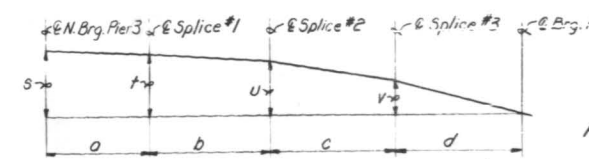
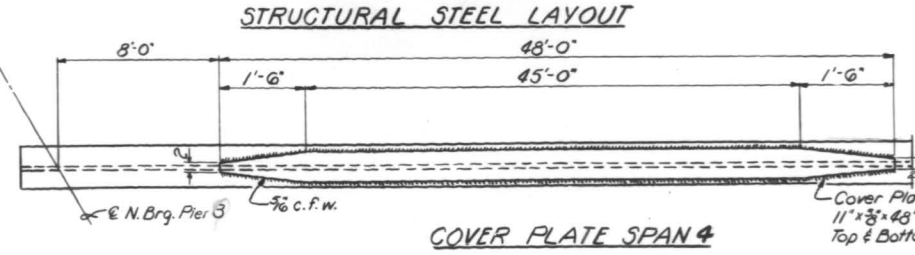
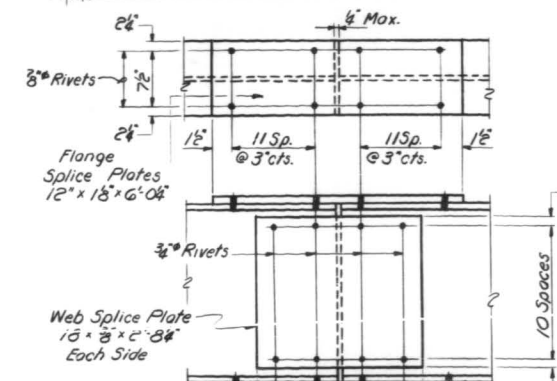
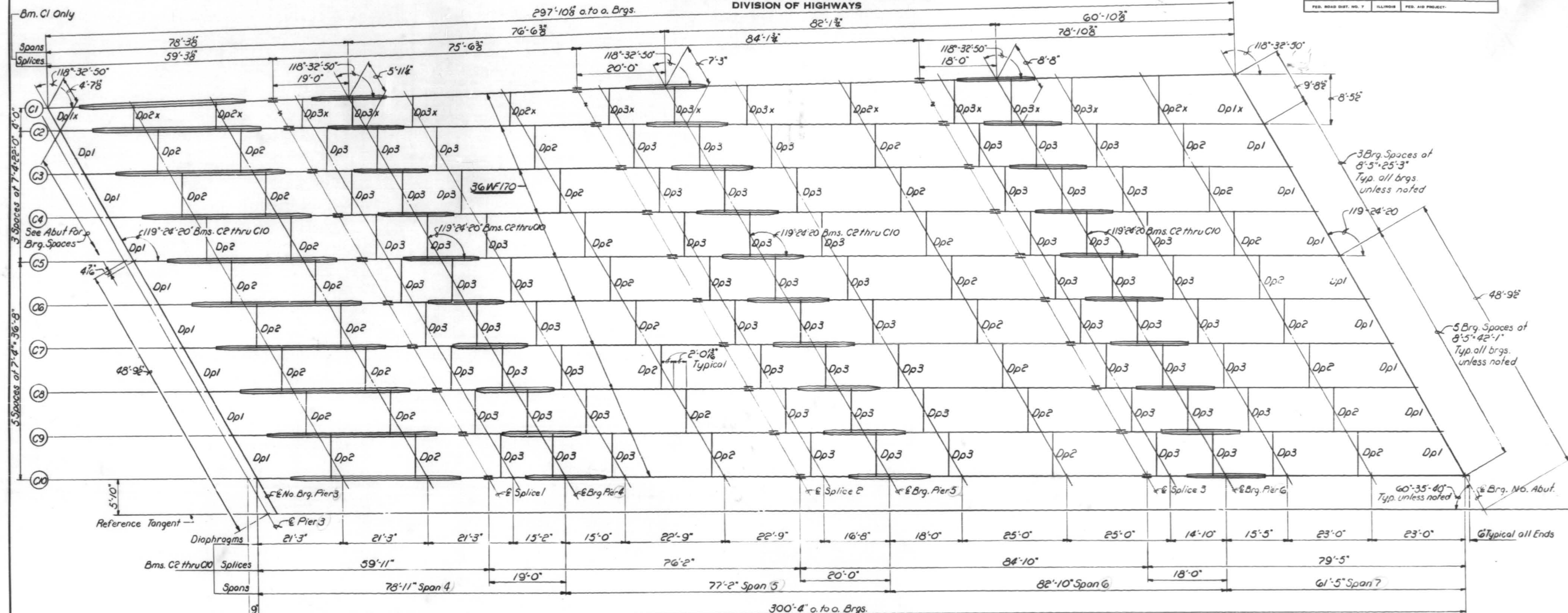

Beams	a	b	c	d	s	t	U	V
C1	59'-3 3/8"	75'-6 3/8"	84'-1 1/2"	78'-10 3/8"	1'-5"	1'-1 1/2"	6 1/2"	4"
C2	59'-11"	76'-2"	84'-10"	79'-5"	1'-5"	1'-1 1/2"	6 1/2"	4"
C3	59'-11"	76'-2"	84'-10"	79'-5"	1'-1 1/2"	10 1/2"	6 1/2"	4"
C4	59'-11"	76'-2"	84'-10"	79'-5"	10 1/2"	10 1/2"	6 1/2"	4"
C5 thru C10	59'-11"	76'-2"	84'-10"	79'-5"	8 1/2"	8 1/2"	6 1/2"	4"

TOP OF BEAM ELEVATIONS

Beams	No. Brg. Pier 3	Splice 1	Pier 4	Splice 2	Pier 5	Splice 3	Pier 6	No. Abut. Brg.
C1	755.23	755.96	755.81	755.36	755.31	755.15	755.08	754.82
C2	756.36	756.09	755.94	755.49	755.44	755.28	755.21	754.95
C3	756.21	755.94	755.86	755.61	755.56	755.40	755.33	755.07
C4	756.07	756.07	755.98	755.73	755.68	755.52	755.45	755.19
C5	756.03	756.03	755.98	755.86	755.81	755.65	755.58	755.32
C6	756.03	756.03	755.98	755.86	755.81	755.65	755.58	755.32
C7	755.86	755.86	755.81	755.69	755.64	755.48	755.41	755.15
C8	755.70	755.70	755.65	755.53	755.48	755.32	755.25	754.99
C9	755.53	755.53	755.48	755.36	755.31	755.15	755.08	754.82
C10	755.36	755.36	755.31	755.19	755.14	754.98	754.91	754.65

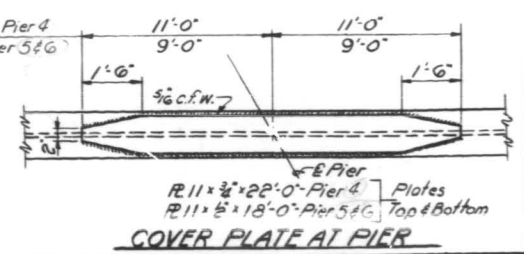

Work this sheet with following sheet

STRUCTURAL STEEL-UNIT C

S.B.I. ROUTE 53

SEC. 531-2-VHB

COOK COUNTY

STATION 270+71.17

DESIGNED: J.A.H.

CHECKED: J.A.H.

DRAWN: W.E. Dickerson

CHECKED: B.C. G.R.

EXAMINED: JUNE 16 1964 Min.

PASSED: W.E. Dickerson

APPROVED: W.E. Dickerson

SPLICE

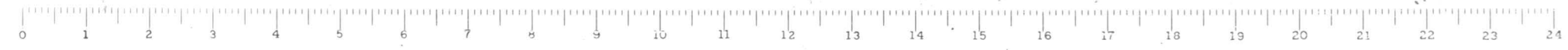

STATE OF ILLINOIS  
DEPARTMENT OF PUBLIC WORKS & BUILDINGS  
DIVISION OF HIGHWAYS

DATE	DESIGN	COUNTY	SHEET NO.	PROJECT NO.
6/11/64	531-2	COOK	67	29
SHEET NO. 24		60 SHEETS		

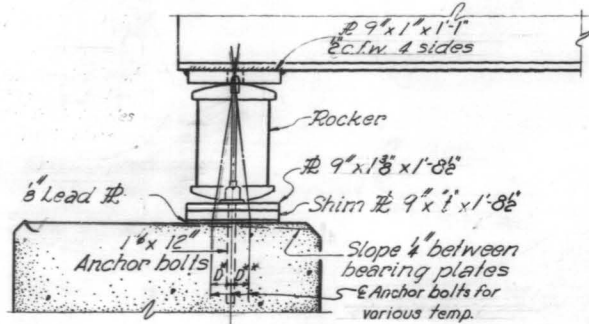

**ELEVATION**

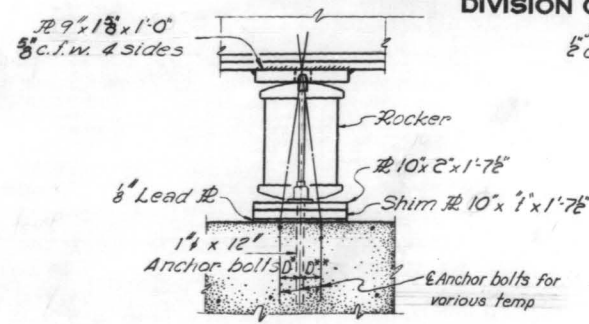

**ELEVATION**

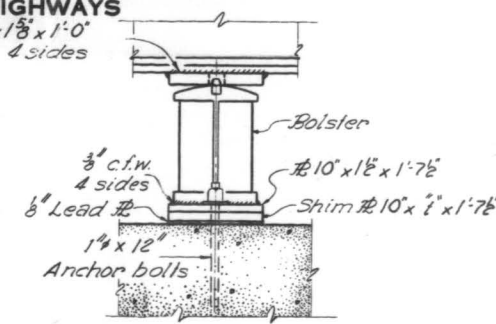

**ELEVATION**



**PINLE**

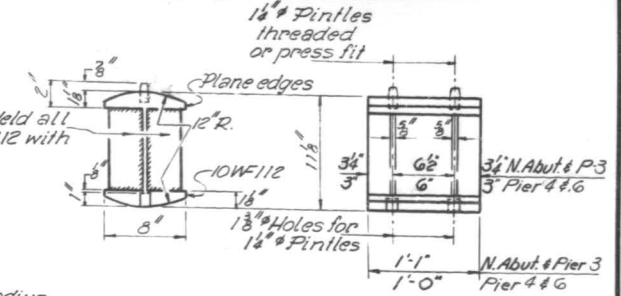

**ROCKER**

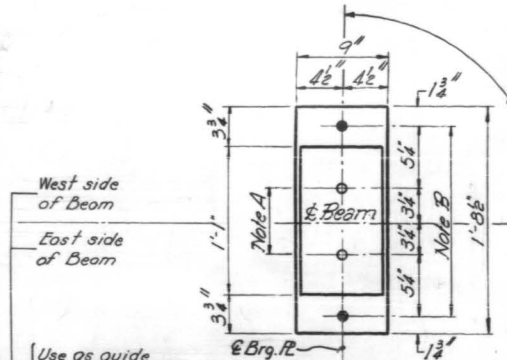

**PLAN**  
@ NO. ABUTMENT  
& NO. BRG. PIER 3

**Note A**  
1 3/8" Holes - 1" deep in top flange for pinles. Thread or press fit pinles into bottom flange.

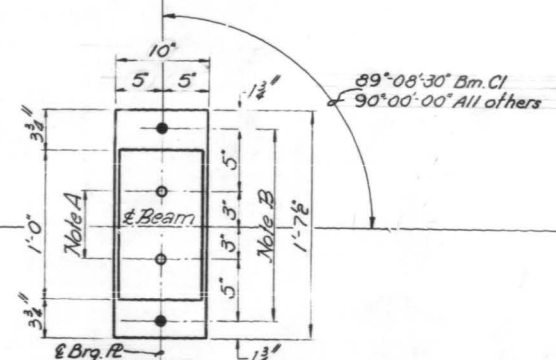

**PLAN**  
@ PIER 4 & 6

**Note B**  
1 1/2" Holes for 1" anchor bolts. 2 1/2 x 2 1/2 x 1 1/2" flange. Washer under nut.

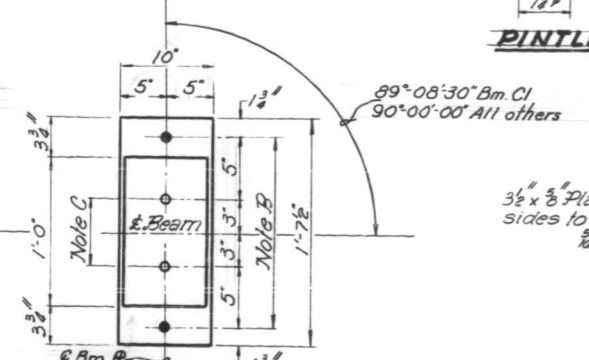

**PLAN**  
@ PIER 5

**Note C**  
1 3/8" Holes - 1" deep in top flange only for 1 1/2" pinles.

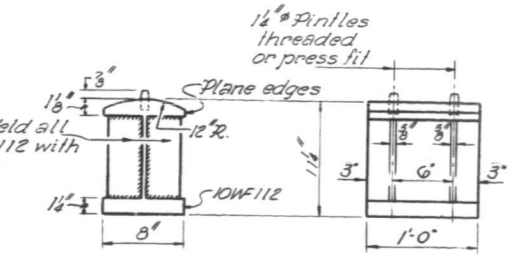

**BOLSTER**

**BEARING ASSEMBLY DETAILS**

**SHIM THICKNESS 7"**

- No. Brg. - Pier 3 - Bm. C2-1 1/2
- C3 - 3/8"
- C4 - 1/2"
- C6 - 1 1/4"
- C7 - 1/2"
- C8 - 3/8"
- Pier 4 - Bm. C2-1 1/2
- C3 - 1/2"

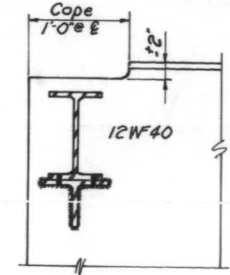

**ELEVATION**

No. Brg. - Pier 3 - b'w'n Bm. C6 & C10 Elev. 755.20  
No. Brg. - Pier 3 - b'w'n Bm. C1 & C6 Elev. 755.87  
No. Abut. Elev. 754.57

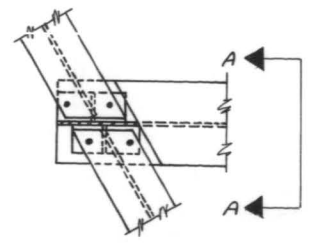

**PLAN**

**DIAPHRAGM Dp1-1x**

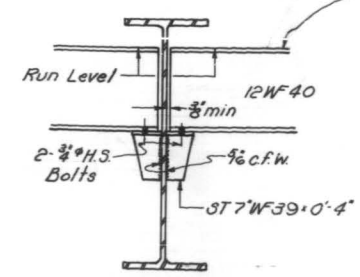

**SECTION A-A**

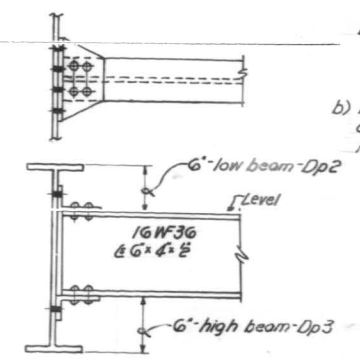

**DIAPHRAGMS Dp2 & Dp3**

**NOTES ON SETTING OF ANCHOR BOLTS AT EXPANSION BRGS**

- D\*\* (Side of brg. away from fixed brg)  
D\* 5/8 per each 100' increment of expansion  
For every 15° fall from temp. of 50°F  
D\*\*\* (Side of brg. toward fixed brg)  
D\*\*\* 5/8 per each 100' increment of expansion  
For every 15° rise from temp. of 50°F
- After beams have been erected and dimension (D\* or D\*\*\*) determined anchor bolts shall be placed in drilled holes and grouted.

DESIGNED	EXAMINED
CHECKED	PAID
DRAWN	APPROVED
CHECKED	

DATE: JUNE 16 1964

**BRGS. & DIAPH. UNIT C**  
S. B. I. ROUTE 53  
SEC. 531-2-VHB  
COOK COUNTY  
STATION 270+71.7

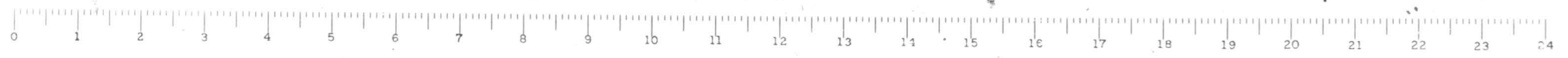

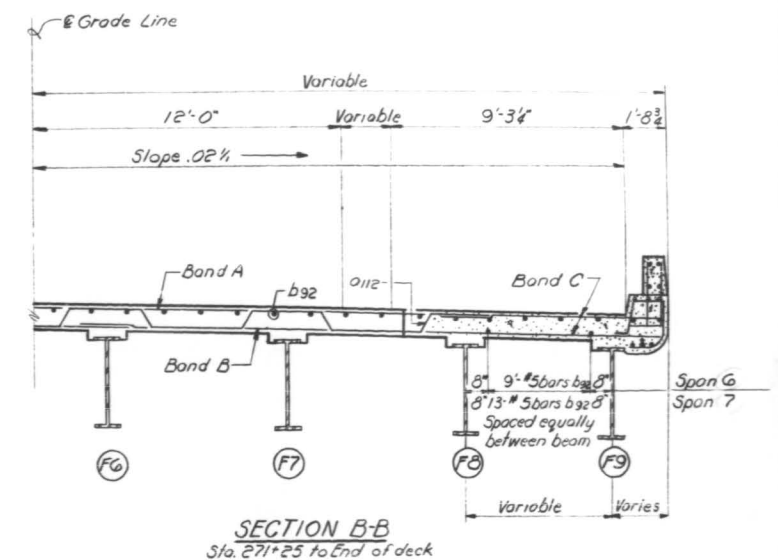
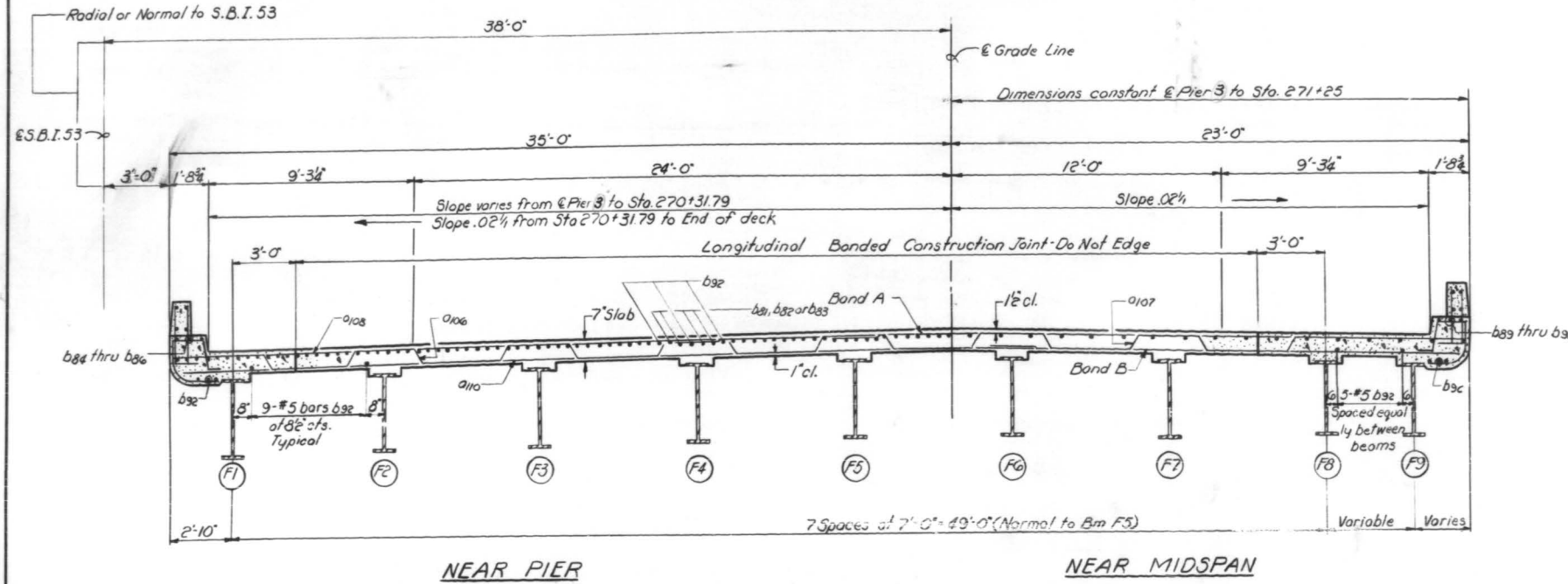

CROSS SECTION

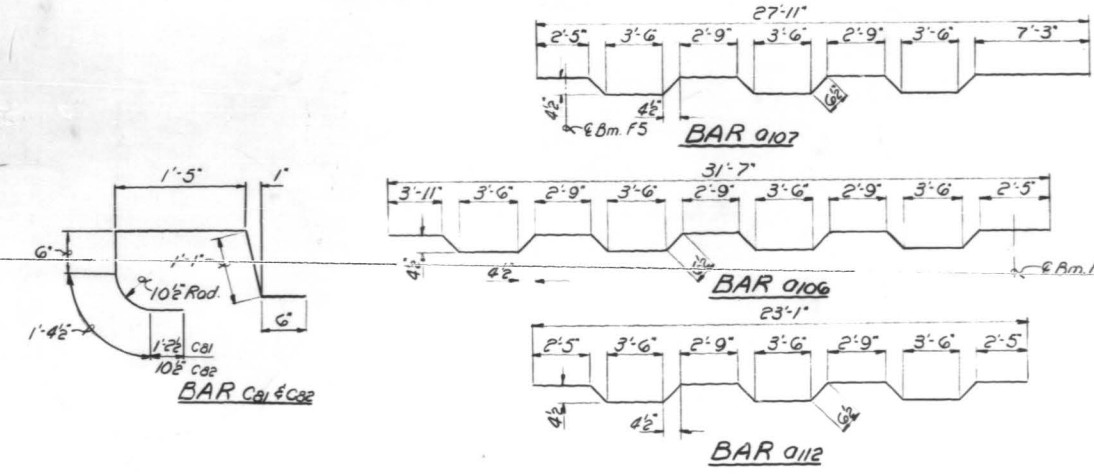
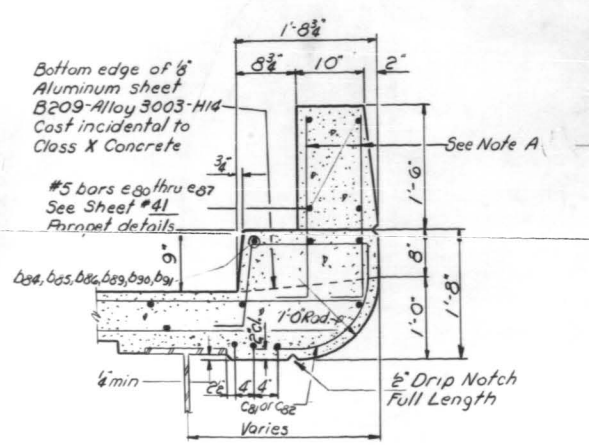

BILL OF MATERIAL

Bar No	Size	Length	Shape	Bar No	Size	Length	Shape	
a84	#7	12'-0"		0121	#6	25'-3"		
a85	#7	11'-6"		0122	#6	26'-0"		
a87	#6	10'-8"		0123	#6	35'-8"		
a88	#6	10'-2"		0124	#6	36'-4"		
a90	#6	9'-3"		0125	#6	37'-0"		
a91	#6	8'-8"		0126	#8	41'-0"		
0100	#6	40'-6"		0127	#8	27'-0"		
0102	#6	39'-6"		0128	#8	41'-9"		
0103	#6	39'-0"		0129	#8	27'-9"		
0104	#6	38'-6"		b81	#6	25'-6"		
0105	#6	38'-0"		b82	#6	25'-0"		
0106	#6	32'-11"	W	b83	#6	24'-6"		
0107	#6	27'-11"	W	b84	#5	11'-9"		
0108	#6	24'-8"		b85	#5	10'-6"		
0109	#6	34'-11"		b86	#5	11'-3"		
0110	#6	38'-8"		b87	#5	27'-6"		
0111	#6	20'-11"		b90	#5	23'-6"		
0112	#6	24'-1"	W	b91	#5	32'-0"		
0113	#6	7'-8"		b92	#5	29'-0"		
0114	#6	12'-6"		c81	#5	6'-1"		
0115	#6	21'-7"		c82	#5	5'-9"		
0116	#6	22'-2"		d80	#5	2'-8"		
0117	#6	22'-10"					Reinforcement Bars	Lbs. 133,350
0118	#6	23'-5"					Structural Steel	Lbs. 568,680
0119	#6	24'-0"					Class X Concrete	Cu. Yds. 6913
0120	#6	24'-6"						

Work this sheet with following sheet

DESIGNED Bobby Chiles  
 CHECKED James W. Warren  
 DRAWN W.E. Dickerson  
 CHECKED J.W.  
 EXAMINED W.E. Dickerson  
 PASSED  
 APPROVED [Signature]  
 JUN 16 1964  
 ENGINEER OF BRIDGES AND TRAFFIC STRUCTURES  
 ENGINEER OF DESIGN  
 CIVIL ENGINEER - E.P.

\*\*Structural steel quantity includes the following  
 1) Bearing Assemblies, including lead plates and anchor bolts. Est. Wt. 3,710 lbs.  
 2) Sliding Plate Expansion Device - includes all material attached (directly or indirectly) to diaphragms of the unit and to the abutment. Est. Wt. 15,850 lbs.  
 \*Reinforcement bars quantity includes e series bars in parapet.

**SUPERSTRUCTURE UNIT F**  
 S.B.I. ROUTE 53  
 SEC. 531-2-VHB  
 COOK COUNTY  
 STATION 270+71.7

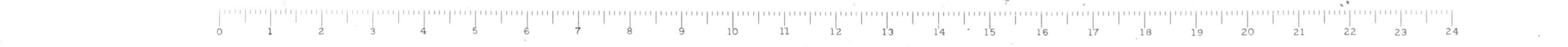



STATE OF ILLINOIS  
DEPARTMENT OF PUBLIC WORKS & BUILDINGS  
DIVISION OF HIGHWAYS

ROUTE NO.	SECTION	COUNTY	TOTAL SHEETS	SHEET NO.
S. I. 53	531-2-VHB	COOK	67	31
SHEET NO. 26 60 SHEETS				

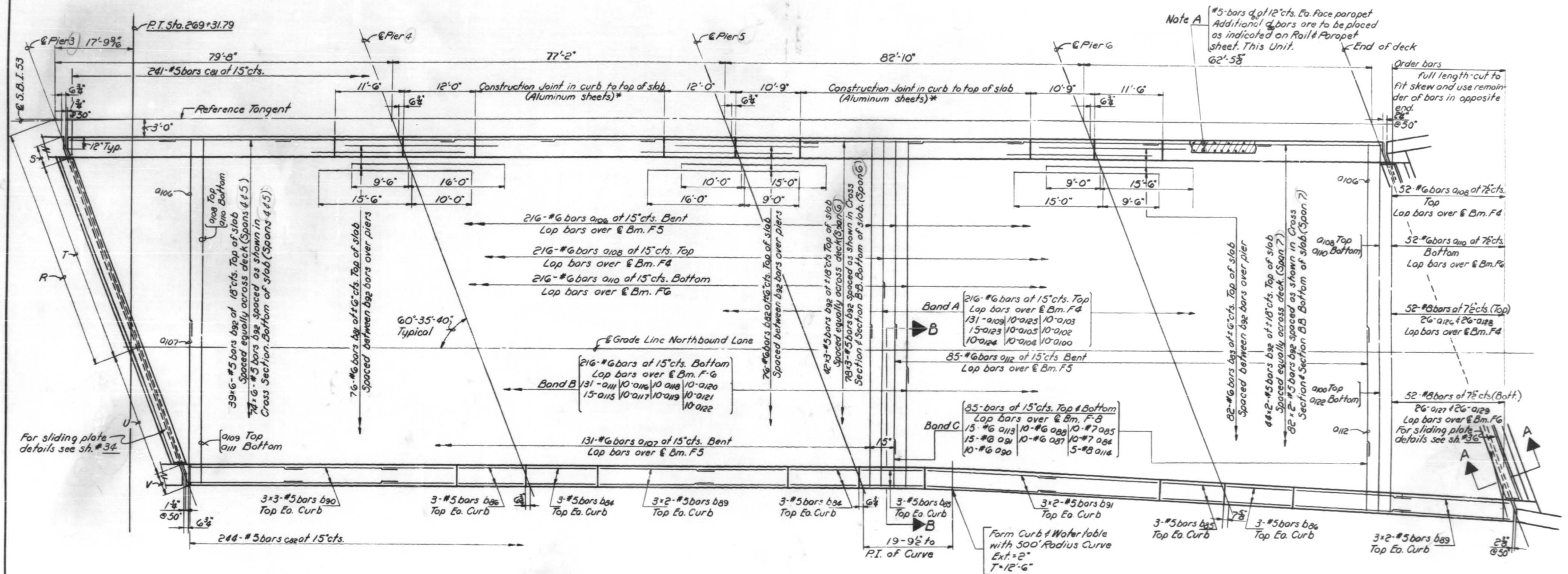

Note A  
#5-bars @ 12" cts. Ea. Face parapet  
Additional #5-bars are to be placed  
as indicated on Rail Parapet  
sheet. This Unit.  
62'-5 1/2"

For sliding plate  
details see sh. #34

NOTE:  
Bars indicated thus 20x3-#5 etc.  
indicates 20 lines of bars with  
3 lengths per line. Lap a series  
bars a min. of 2'-0". Lap all b  
series a min. of 20 diameters.  
\*Place Aluminum sheets normal  
to water table.

Location	R	S	T	U	V
€ Pier 3	43'-7 1/2"	1'-11 1/2"	38'-2"	24'-5"	1'-11 1/2"
€ Pier 4	43'-7 1/2"	1'-11 1/2"	38'-2"	24'-5"	1'-11 1/2"
€ Pier 5	43'-7 1/2"	1'-11 1/2"	38'-2"	24'-5"	1'-11 1/2"
€ Pier 6	43'-7 1/2"	1'-11 1/2"	38'-2"	28'-3 1/2"	2'-0 1/2"
End of Jack	43'-7 1/2"	1'-11 1/2"	38'-2"	32'-2 1/2"	2'-0 1/2"

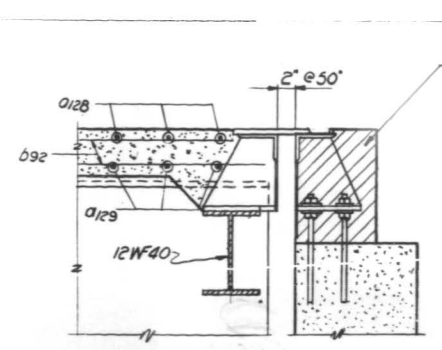

Hatched area to be poured  
after superstructure forms  
have been removed.  
Quantity of Class X Concrete  
included with superstructure

Work this sheet with preceding sheet.

DESIGNED *Bobby Chilton*  
CHECKED *J. W. Dickerson*  
DRAWN *W.E. Dickerson*  
CHECKED *J.W.*

EXAMINED *W.E. Dickerson*  
PASSED *Chilton*  
APPROVED *J.W. Dickerson*

JUNE 16 1964

**SUPERSTRUCTURE-UNIT F**  
S.B.I. ROUTE 53  
SEC. 531-2-VHB  
COOK COUNTY  
STATION 270+71.17



STATE OF ILLINOIS  
DEPARTMENT OF PUBLIC WORKS & BUILDINGS  
DIVISION OF HIGHWAYS

ROUTE NO.	SECTION	COUNTY	TOTAL SHEETS	SHEET NO.	SHEET NO. 27 60 SHEETS
53	531-2-VHB	COOK	67	32	
FED. ROAD DIST. NO. 1		ILLINOIS	FED. AID PROJECT		

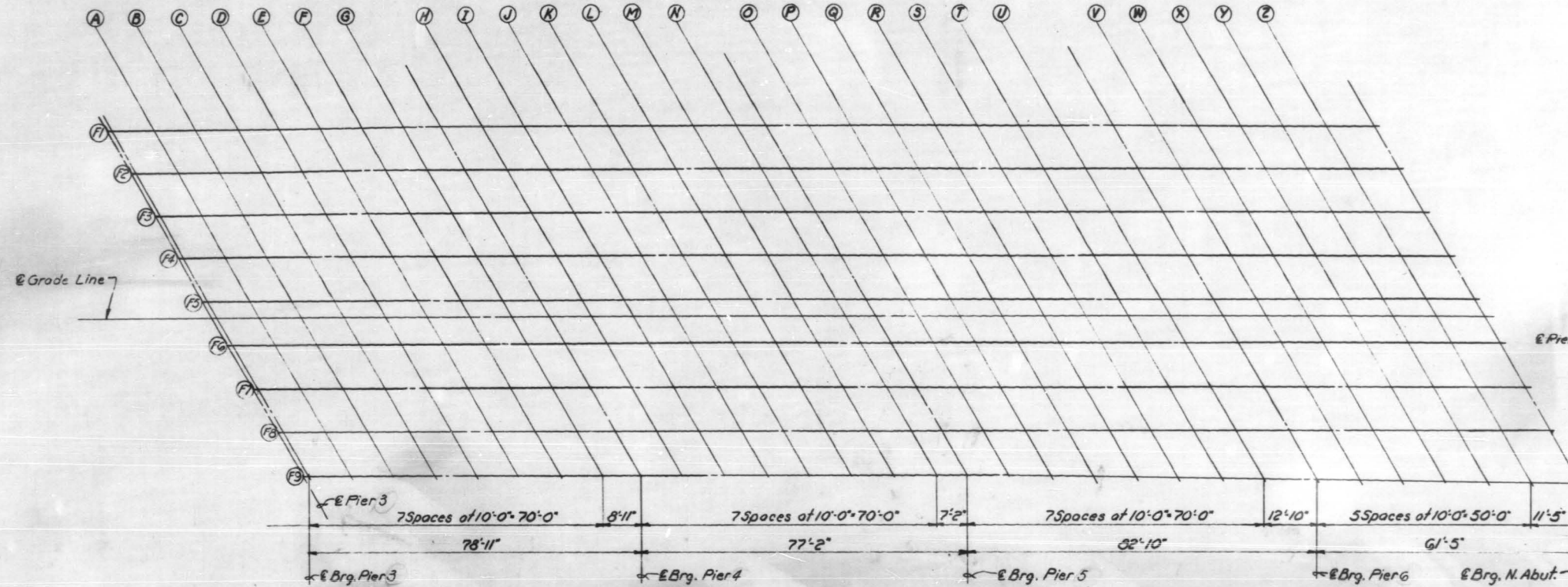

Beam	Station	Offset	Theoretical Grade Elevations	Theoretical Grade Elevations Adjusted For Dead Load Deflection
M-F1	27026.948	32.166	755.944	755.934
M-F9	27086.673	20.575	756.085	756.075
N-F1	27066.948	32.166	755.916	755.912
N-F9	27096.822	20.841	756.043	756.039
E Pier 5-F1	27074.114	32.166	755.894	755.894
E Pier 5-F9	27104.097	21.032	756.012	756.012
O-F1	27084.114	32.166	755.862	755.875
O-F9	27114.247	21.297	755.967	755.960
P-F1	27094.114	32.166	755.827	755.854
P-F9	27124.397	21.563	755.912	755.945
Q-F1	27104.114	32.166	755.790	755.828
Q-F9	27134.547	21.829	755.868	755.906
R-F1	27114.114	32.166	755.790	755.800
R-F9	27144.696	22.095	755.814	755.811
S-F1	27124.114	32.166	755.708	755.749
S-F9	27154.846	22.361	755.758	755.799
T-F1	27134.114	32.166	755.663	755.693
T-F9	27164.996	22.626	755.700	755.730
U-F1	27144.114	32.166	755.616	755.633
U-F9	27175.225	23.034	755.635	755.653
E Pier 6-F1	27156.948	32.166	755.551	755.551
E Pier 6-F9	27188.450	23.726	755.544	755.544
V-F1	27166.948	32.166	755.498	755.501
V-F9	27198.754	24.266	755.471	755.474
W-F1	27176.948	32.166	755.443	755.453
W-F9	27209.058	24.806	755.394	755.404
X-F1	27186.948	32.166	755.385	755.407
X-F9	27219.362	25.346	755.316	755.338
Y-F1	27196.948	32.166	755.324	755.347
Y-F9	27229.666	25.885	755.235	755.258
Z-F1	27206.948	32.166	755.261	755.279
Z-F9	27239.072	26.425	755.152	755.166
E Brg. N. Abut. F1	27218.364	32.166	755.186	755.186
E Brg. N. Abut. F9	27251.734	27.041	755.052	755.052

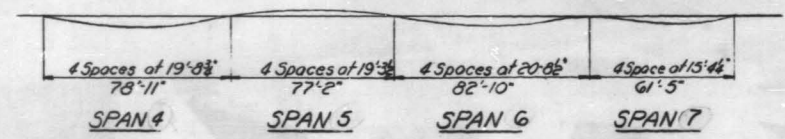

Beam	Span 4	Span 5	Span 6	Span 7
F1	1/4"	1"	3/8"	1/2"
F2 thru F8	3/8"	1/2"	3/4"	1"
F9	1/2"	3/4"	1"	1 1/4"

**DEAD LOAD DEFLECTION DIAGRAM**  
Includes weight of concrete only.

Note: The above deflections are not for use in the field if the Engineer is working from the Theoretical Grade Elevation Adjusted for Dead Load Deflection.

DESIGNED	J. W. Nelson	EXAMINED	W. E. Baumann
CHECKED	J. W. Nelson	PASSED	[Signature]
DRAWN	W. E. Dickerson	APPROVED	[Signature]
CHECKED	G. R.		

Beam	Station	Offset	Theoretical Grade Elevations	Theoretical Grade Elevations Adjusted For Dead Load Deflection
E Brg. Pier 3-F1	26918.031	32.166	756.806	756.806
E Brg. Pier 3-F9	26947.714	20.500	756.320	756.320
A-F1	26928.031	32.166	756.748	756.781
A-F9	26947.714	20.500	756.319	756.352
B-F1	26938.031	32.166	756.688	756.754
B-F9	26967.714	20.500	756.316	756.382
C-F1	26948.031	32.166	756.625	756.699
C-F9	26977.714	20.500	756.310	756.384
D-F1	26958.031	32.166	756.560	756.640
D-F9	26987.714	20.500	756.302	756.381
E-F1	26968.031	32.166	756.493	756.552
E-F9	26997.714	20.500	756.296	756.371
F-F1	26978.031	32.166	756.423	756.463
F-F9	27007.714	20.500	756.278	756.318
G-F1	26988.031	32.166	756.350	756.369
G-F9	27017.714	20.500	756.263	756.282
E Pier 4-F1	26996.948	32.166	756.283	756.283
E Pier 4-F9	27026.630	20.500	756.247	756.247
H-F1	27006.948	32.166	756.206	756.199
H-F9	27036.630	20.500	756.226	756.219
I-F1	27016.948	32.166	756.126	756.113
I-F9	27046.630	20.500	756.203	756.190
J-F1	27026.948	32.166	756.044	756.035
J-F9	27056.630	20.500	756.178	756.169
K-F1	27036.948	32.166	755.992	755.987
K-F9	27066.630	20.500	756.110	756.144
L-F1	27046.948	32.166	755.969	755.961
L-F9	27076.630	20.500	756.120	756.111

**SLAB ELEVATIONS-UNIT F**  
S.B.I. ROUTE 53  
SEC. 531-2-VHB  
COOK COUNTY  
STATION 270+71.17





STATE OF ILLINOIS  
DEPARTMENT OF PUBLIC WORKS & BUILDINGS  
DIVISION OF HIGHWAYS

ROUTE NO.	SECTION	COUNTY	TOTAL SHEETS	SHEET NO.	SHEET NO. 27
53	531-2-VHB	COOK	67	32	60 SHEETS
61	-VHB				

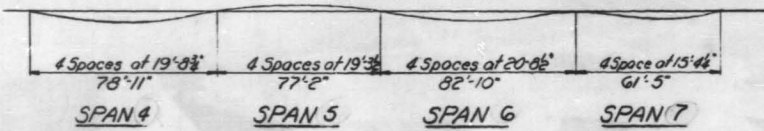
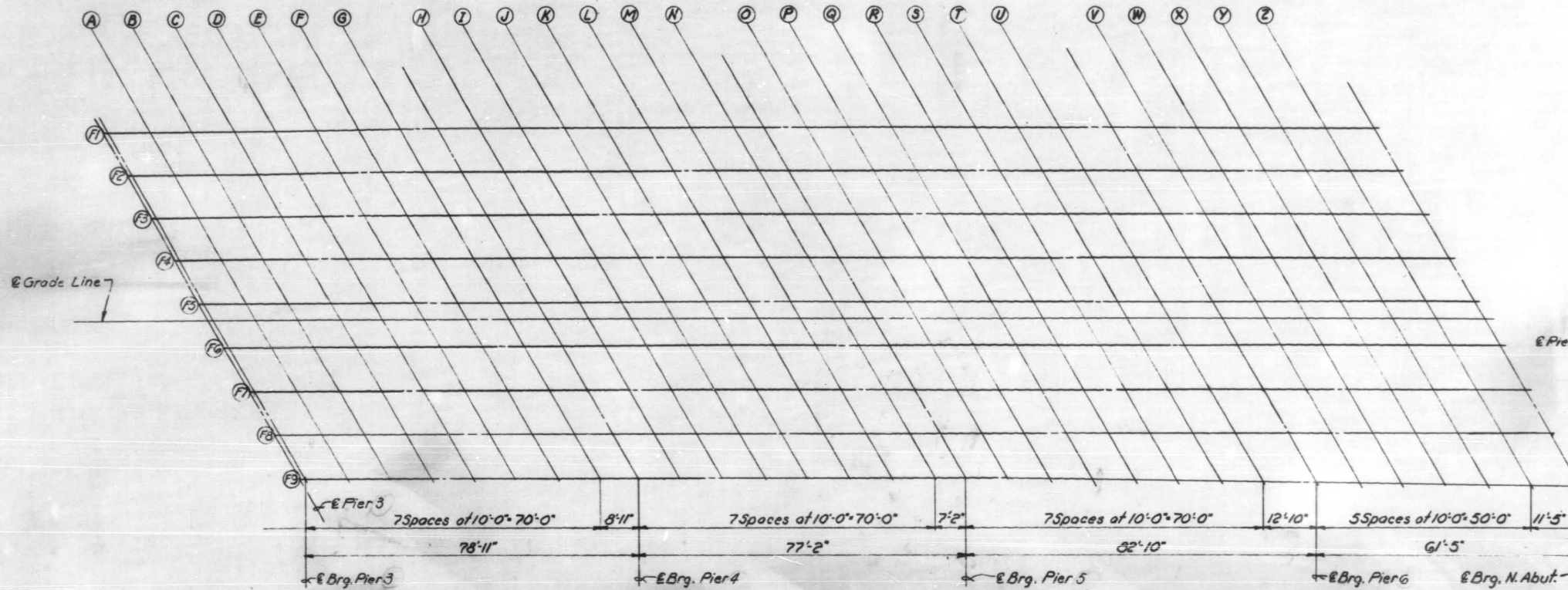

Beam	Span 4			Span 5			Span 6			Span 7		
	1/4	1/2	3/4	1/4	1/2	3/4	1/4	1/2	3/4	1/4	1/2	3/4
F1	9/16	1/8	3/16	-3/16	-1/16	-1/8	3/16	1/8	3/16	1/16	1/8	3/16
F2 thru F8	9/16	1/8	3/16	-1/8	-1/16	-1/8	3/16	1/8	3/16	1/16	3/16	3/16
F9	3/8	1/8	1/2	-1/8	-1/16	-1/8	3/16	1/8	3/16	1/8	3/8	3/8

**DEAD LOAD DEFLECTION DIAGRAM**

Includes weight of concrete only.

Note: The above deflections are not for use in the field if the Engineer is working from the Theoretical Grade Elevation Adjusted for Dead Load Deflection.

DESIGNED	J. W. Nelson
CHECKED	John R. ...
DRAWN	W.E. Dickerson
CHECKED	G. R.

DATE	JUNE 16 1914
EXAMINED	W.E. Baumann
PASSED	[Signature]
APPROVED	[Signature]

Beam	Station	Offset	Theoretical Grade Elevations	Theoretical Grade Elevations Adjusted For Dead Load Deflection
M-F1	27026.948	32.166	755.944	755.934
M-F9	27086.673	20.575	756.085	756.075
N-F1	27066.948	32.166	755.916	755.912
N-F9	27096.822	20.841	756.043	756.039
E Pier 5-F1	27074.114	32.166	755.894	755.894
E Pier 5-F9	27104.097	21.032	756.012	756.012
O-F1	27084.114	32.166	755.862	755.875
O-F9	27114.247	21.297	755.967	755.960
P-F1	27094.114	32.166	755.827	755.854
P-F9	27124.397	21.563	755.912	755.945
Q-F1	27104.114	32.166	755.790	755.828
Q-F9	27134.547	21.829	755.868	755.906
R-F1	27114.114	32.166	755.790	755.800
R-F9	27144.696	22.095	755.814	755.811
S-F1	27124.114	32.166	755.708	755.749
S-F9	27154.846	22.361	755.758	755.799
T-F1	27134.114	32.166	755.663	755.693
T-F9	27164.996	22.626	755.700	755.730
U-F1	27144.114	32.166	755.616	755.633
U-F9	27175.225	23.034	755.635	755.653
E Pier 6-F1	27156.948	32.166	755.551	755.551
E Pier 6-F9	27188.450	23.726	755.544	755.544
V-F1	27166.948	32.166	755.498	755.501
V-F9	27198.754	24.266	755.471	755.474
W-F1	27176.948	32.166	755.443	755.453
W-F9	27209.058	24.806	755.390	755.404
X-F1	27186.948	32.166	755.385	755.407
X-F9	27219.362	25.346	755.316	755.338
Y-F1	27196.948	32.166	755.324	755.347
Y-F9	27229.666	25.885	755.235	755.258
Z-F1	27206.948	32.166	755.261	755.279
Z-F9	27239.072	26.425	755.151	755.166
E Brg. N. Abut. F1	27218.364	32.166	755.186	755.186
E Brg. N. Abut. F9	27251.734	27.041	755.052	755.052

Beam	Station	Offset	Theoretical Grade Elevations	Theoretical Grade Elevations Adjusted For Dead Load Deflection
E Brg. Pier 3-F1	26918.031	32.166	756.806	756.806
E Brg. Pier 3-F9	26947.714	20.500	756.320	756.320
A-F1	26928.031	32.166	756.748	756.781
A-F9	26957.714	20.500	756.319	756.342
B-F1	26938.031	32.166	756.688	756.754
B-F9	26967.714	20.500	756.316	756.382
C-F1	26948.031	32.166	756.625	756.699
C-F9	26977.714	20.500	756.310	756.384
D-F1	26958.031	32.166	756.560	756.640
D-F9	26987.714	20.500	756.302	756.381
E-F1	26968.031	32.166	756.493	756.552
E-F9	26997.714	20.500	756.294	756.371
F-F1	26978.031	32.166	756.423	756.463
F-F9	27007.714	20.500	756.278	756.318
G-F1	26988.031	32.166	756.350	756.369
G-F9	27017.714	20.500	756.263	756.282
E Pier 4-F1	26996.948	32.166	756.283	756.283
E Pier 4-F9	27026.630	20.500	756.247	756.247
H-F1	27006.948	32.166	756.206	756.199
H-F9	27036.630	20.500	756.226	756.219
I-F1	27016.948	32.166	756.126	756.113
I-F9	27046.630	20.500	756.203	756.190
J-F1	27026.948	32.166	756.044	756.035
J-F9	27056.630	20.500	756.178	756.169
K-F1	27036.948	32.166	755.992	755.987
K-F9	27066.630	20.500	756.110	756.144
L-F1	27046.948	32.166	755.969	755.961
L-F9	27076.630	20.500	756.120	756.111

**SLAB ELEVATIONS-UNIT F**  
S.B.I. ROUTE 53  
SEC. 531-2-VHB  
COOK COUNTY  
STATION 270+71.7

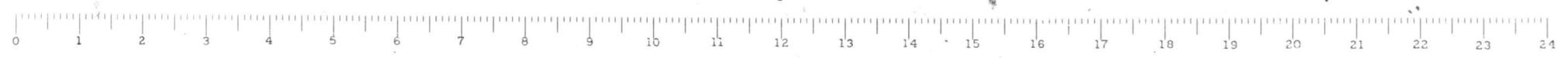

STATE OF ILLINOIS  
DEPARTMENT OF PUBLIC WORKS & BUILDINGS  
DIVISION OF HIGHWAYS

ROUTE NO. 53  
SECTION 531-2  
COUNTY COOK  
TOTAL SHEETS 67  
SHEET NO. 33  
SHEETS 60 SHEETS

Beam	Station	Offset	Theoretical Grade Elevations	Theoretical Grade Elevations Adjusted For Dead Load Deflection
<b>§ Brg. Pier 3</b>				
F2	26921.976	- 25.166	756.170	756.170
F3	26925.921	- 18.166	756.144	756.144
F4	26939.866	- 11.166	756.129	756.129
F5	26933.812	- 4.166	756.125	756.125
G.L.	26936.160	.000	756.728	756.728
F6	26937.757	2.833	756.671	756.671
F7	26941.702	9.833	756.532	756.532
F8	26945.647	16.833	756.393	756.393
<b>§ Brg. Pier 4</b>				
F2	26931.976	- 25.166	756.725	756.749
F3	26935.921	- 18.166	756.713	756.736
F4	26943.812	- 11.166	756.711	756.734
F5	26943.812	- 4.166	756.720	756.743
G.L.	26946.160	.000	756.730	756.753
F6	26947.757	2.833	756.673	756.697
F7	26951.702	9.833	756.533	756.557
F8	26955.647	16.833	756.393	756.417
<b>§ Brg. Pier 5</b>				
F2	27001.893	- 25.166	756.390	756.390
F3	27044.838	- 18.166	756.427	756.427
F4	27008.783	- 11.166	756.515	756.515
F5	27012.728	- 4.166	756.613	756.613
G.L.	27016.674	.000	756.677	756.677
F6	27020.619	2.833	756.618	756.618
F7	27020.619	9.833	756.471	756.471
F8	27024.564	16.833	756.324	756.324
<b>§ Brg. Pier 6</b>				
F2	27088.059	- 25.166	756.022	756.022
F3	27082.005	- 18.166	756.149	756.149
F4	27085.950	- 11.166	756.276	756.276
F5	27089.895	- 4.166	756.402	756.402
G.L.	27092.243	.000	756.477	756.477
F6	27093.840	2.833	756.415	756.415
F7	27097.785	9.833	756.260	756.260
F8	27101.731	16.833	756.106	756.106

DESIGNED J.H. Nelson  
EXAMINED W.E. Dickerson  
CHECKED Janna Roman  
DRAWN W.E. Dickerson  
CHECKED G.R.  
JUNE 16 1964  
APPROVED [Signature]  
LIFE MEMBER ENGINEER

SLAB ELEVATIONS-UNIT F  
S.B.I. ROUTE 53  
SEC. 531-2-VHB  
COOK COUNTY  
STATION 270+71.17





STATE OF ILLINOIS  
DEPARTMENT OF PUBLIC WORKS & BUILDINGS  
DIVISION OF HIGHWAYS

ROUTE NO.	SECTION	COUNTY	TOTAL SHEETS	SHEET NO.	SHEET NO. 79
R. R. 1. 53	531-2	COOK	67	34	60 SHEETS
P. A. 61	VHB				
FED. ROAD DIST. NO. 7	ILLINOIS	FED. AID PROJECT			

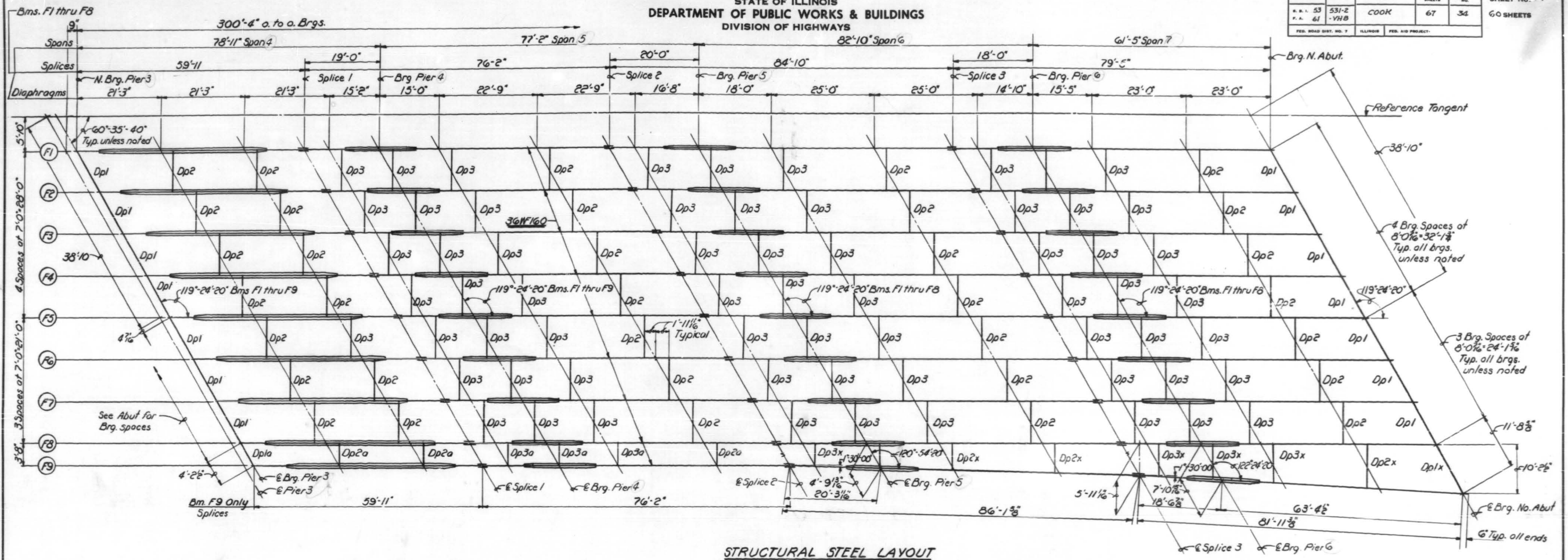

STRUCTURAL STEEL LAYOUT

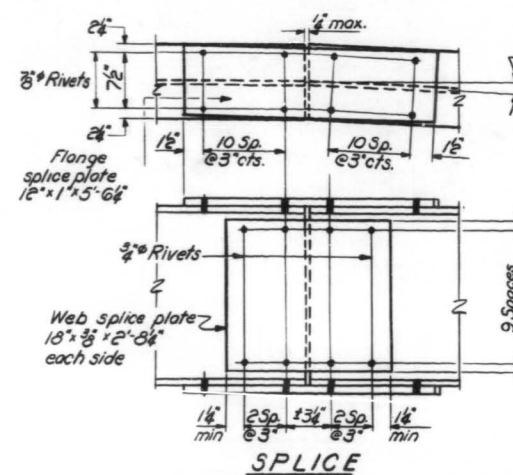

SPLICE

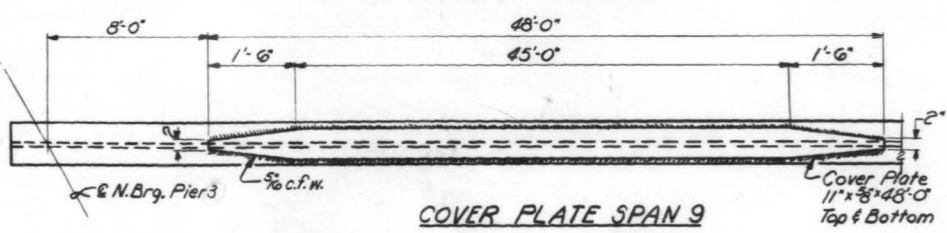

COVER PLATE SPAN 9

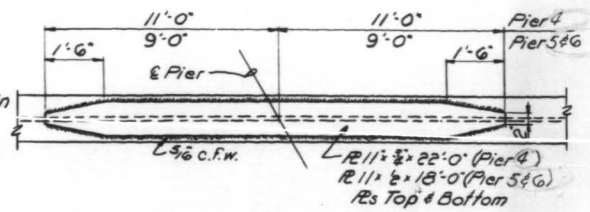

COVER PLATE AT PIER

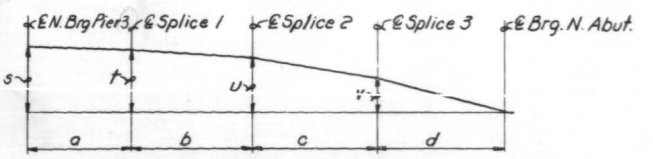

FABRICATION DIAGRAM

Beams	a	b	c	d	s	t	u	v
F1 & F2	59'-11"	76'-2"	84'-10"	79'-5"	1'-7 1/2"	1'-3 1/2"	10 1/2"	6 1/2"
F3 & F4	59'-11"	76'-2"	84'-10"	79'-5"	1'-4"	1'-1 1/2"	10 1/2"	6 1/2"
F5 thru F8	59'-11"	76'-2"	84'-10"	79'-5"	1'-2"	1'-1 1/2"	10 1/2"	6 1/2"
F9	59'-11"	76'-2"	86'-1 1/2"	81'-11 1/2"	1'-2"	1'-1 1/2"	10 1/2"	6 1/2"

TOP OF BEAM ELEVATIONS

Beams	No. Brg. Pier 3	Splice 1	Pier 4	Splice 2	Pier 5	Splice 3	Pier 6	No. Abut. Brg.
F1	755.04	755.69	755.59	755.27	755.20	754.96	754.84	754.42
F2	755.16	755.81	755.71	755.39	755.32	755.02	754.96	754.54
F3	755.00	755.77	755.71	755.52	755.45	755.21	755.09	754.67
F4	755.12	755.89	755.83	755.64	755.57	755.33	755.21	754.79
F5	755.08	755.02	755.96	755.77	755.70	755.46	755.34	754.92
F6	755.08	755.02	755.96	755.77	755.70	755.46	755.34	754.92
F7	755.93	755.87	755.81	755.62	755.55	755.31	755.19	754.77
F8	755.79	755.73	755.67	755.48	755.41	755.17	755.05	754.63
F9	755.64	755.58	755.52	755.33	755.26	755.02	754.90	754.48

DESIGNED *J. B. N. A.*  
CHECKED *W. E. Dickerson*  
DRAWN *W. E. Dickerson*  
CHECKED *GR.*

EXAMINED *W. E. Dickerson*  
PASSED *W. E. Dickerson*  
APPROVED *W. E. Dickerson*

JUNE 16 1964

STRUCTURAL STEEL-UNIT F  
S. B. I. ROUTE 53  
SEC. 531-2-VHB  
COOK COUNTY  
STATION 270+71.7

Work this sheet with the following sheet





STATE OF ILLINOIS  
DEPARTMENT OF PUBLIC WORKS & BUILDINGS  
DIVISION OF HIGHWAYS

PROJECT NO.	SECTION	COUNTY	TOTAL SHEETS	SHEET NO.
531-2	VHB	COOK	67	35

SHEET NO. 30  
60 SHEETS

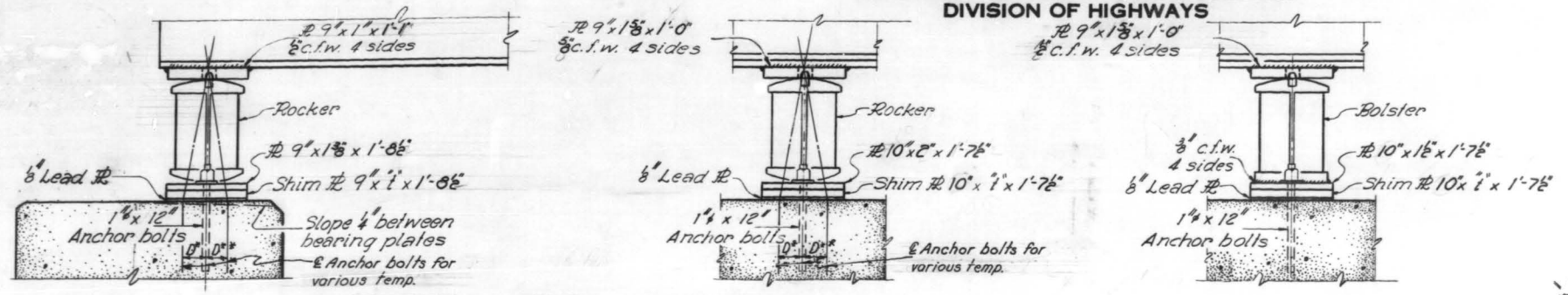

**ELEVATION**

**ELEVATION**

**ELEVATION**

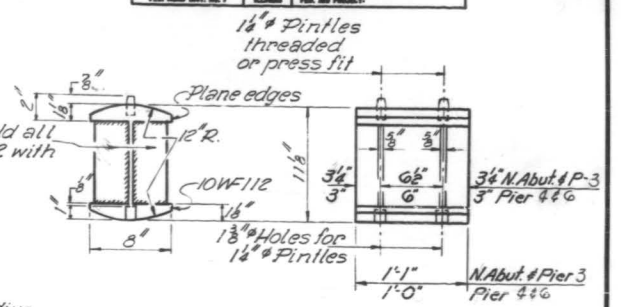

**ROCKER**

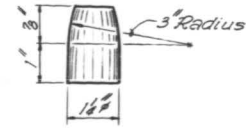

**PINTLE**

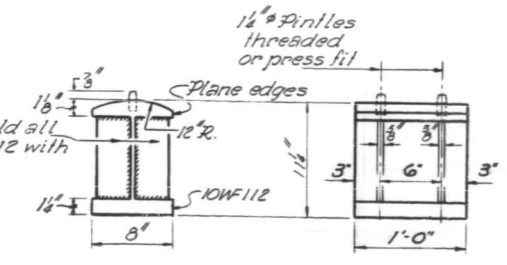

**BOLSTER**

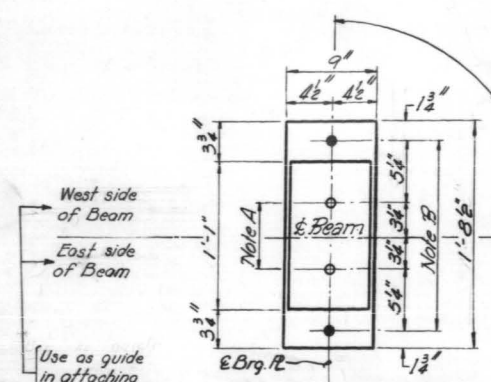

**PLAN**  
NO. ABUTMENT  
NO. BRG. PIER 3

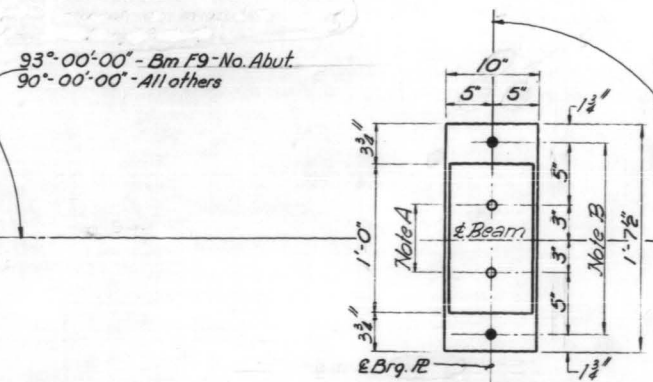

**PLAN**  
PIER 466

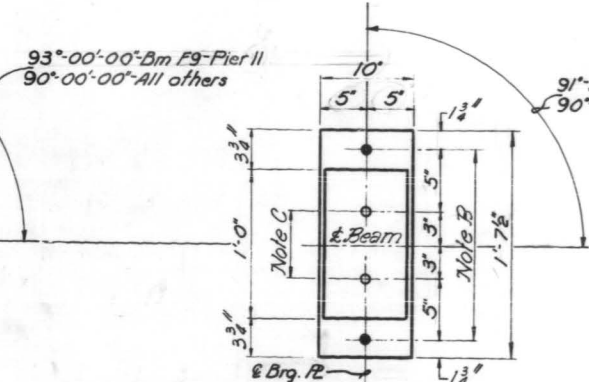

**PLAN**  
PIER 3

Note A  
1 3/8" Holes - 1" deep in top flange for pintles. Thread or press fit pintles into bottom flange.

Note B  
1 1/2" Holes for 1" anchor bolts. 2 1/2 x 2 1/2 x 1/8" flange. Washer under nut.

Note C  
1 3/8" Holes - 1" deep in top flange only for 1 1/2" pintles.

**BEARING ASSEMBLY DETAILS**

**SHIM THICKNESS 7"**

No. Brg. Pier 3 - Bm. F1	3/8"
Bm. F2	2 3/8"
Bm. F3	3/8"
Bm. F4	3/8"
Bm. F5	3/8"
Bm. F6	3/8"

Pier 4 - Bm. F9 - 4"  
Pier 5 - Bm. F1 - 4"  
Pier 6 - Bm. F1 - 4"

No shims req'd at any other brgs.

**NOTES ON SETTING OF ANCHOR BOLTS AT EXPANSION BRGS**

- D\* (Side of brg. away from fixed brg.)  
D\* = 5/8" per each 100' increment of expansion for every 15° fall from temp. of 50°F  
D\*\* (Side of brg. toward fixed brg.)  
D\*\* = 5/8" per each 100' increment of expansion for every 15° rise from temp. of 50°F
- After beams have been erected and dimension (D\* or D\*\*) determined anchor bolts shall be placed in drilled holes and grouted.

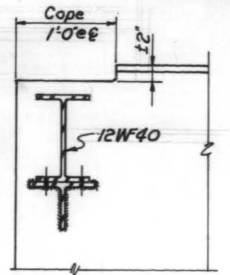

**ELEVATION**

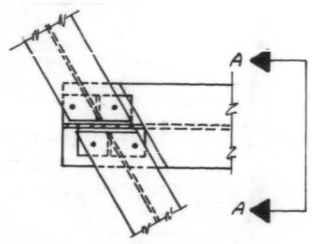

**PLAN**

DIAPHRAGM Dp1-1a-1x

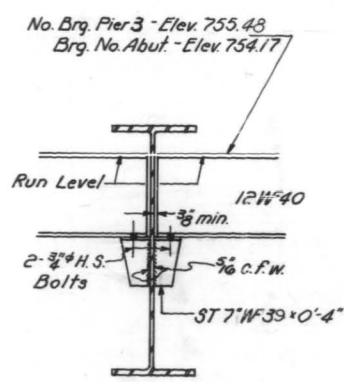

**SECTION A-A**

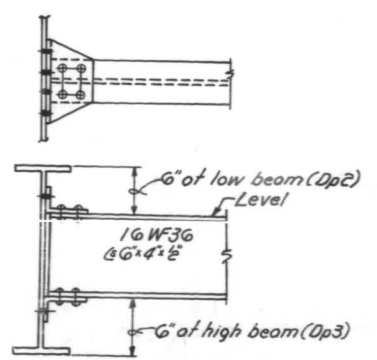

**DIAPHRAGMS Dp2 & Dp3**

Work this sheet with preceding sheet

**BRGS & DIAPH-UNIT F**  
S.B.I. ROUTE 53  
SEC. 531-2-VHB  
COOK COUNTY  
STATION 270+71.17

DESIGNED: James Hartung  
CHECKED: J. C. Muller  
DRAWN: J. C. Muller  
CHECKED: J.W. G.R.

JUNE 16 1964  
EXAMINED: W. G. Burmann  
APPROVED: [Signature]



STATE OF ILLINOIS  
DEPARTMENT OF PUBLIC WORKS & BUILDINGS  
DIVISION OF HIGHWAYS

ROUTE NO.	SECTION	COUNTY	TOTAL SHEETS	SHEET NO.	SHEET NO. 31 60 SHEETS
S. R. I. 53	531-2	COOK	67	36	
P. A. 46	-VHB				
FED. ROAD DIST. NO. 7	ILLINOIS	FED. AID PROJECT			

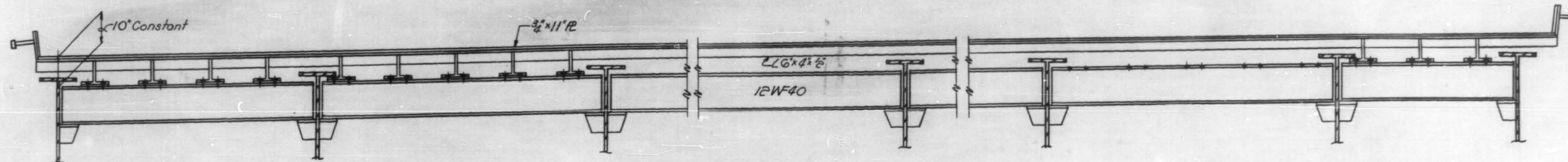

ELEVATION

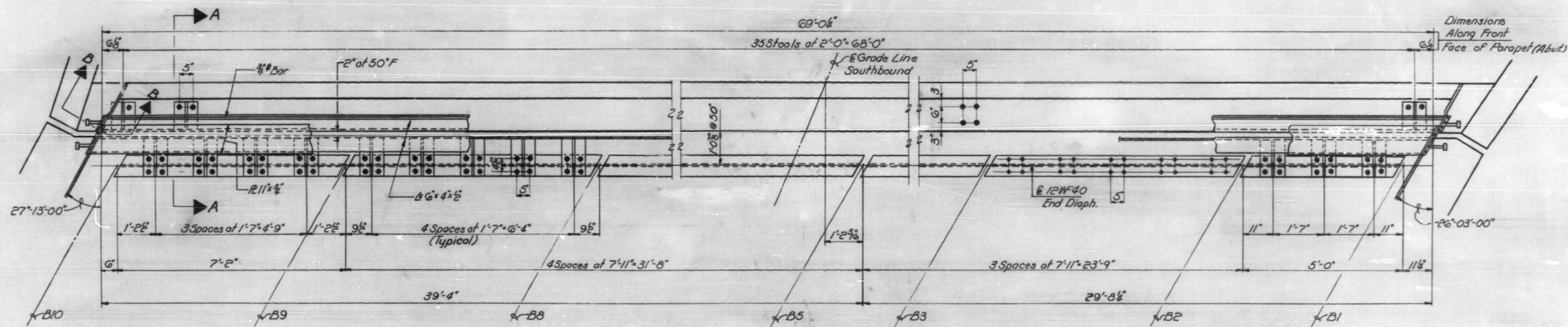

PLAN

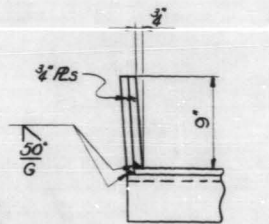

SECTION B-B

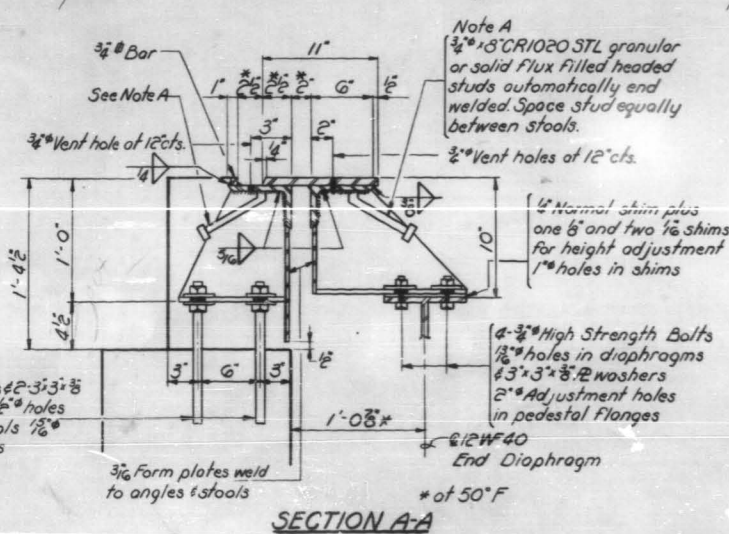

SECTION A-A

DESIGNED *Dobby Chiles*  
CHECKED *James Waring*  
DRAWN *W.E. Dickerson*  
CHECKED *J.W.*

EXAMINED *W.E. Baumann*  
PASSED *Eberhart*  
APPROVED *[Signature]*

JUNE 16 1964

All stools cut from 2" x 11" x 68" (1 Cut 2)

4-3/8" x 1-1/8" anchor bolts @ 2-3/4" x 3-1/2" x 5/8" washers each bolt. 1/2" holes for adjustment in stools. 1/8" holes in plate washers

Note A  
3/4" x 5" CR1020 STL granular or solid flux filled headed studs automatically end welded. Space stud equally between stools.

3/8" Vent holes at 12" cts.

1/2" Normal shims plus one 5/8" and two 1/8" shims for height adjustment. 1" holes in shims.

4-3/8" High Strength Bolts  
1/8" holes in diaphragms  
6-3/8" x 3-1/2" x 5/8" washers  
2" Adjustment holes in pedestal flanges

EXPAN. DEVICE SO. ABUT. UNIT B  
S.B.I. ROUTE 53  
SEC. 531-2-VHB  
COOK COUNTY  
STATION 270+71.17





STATE OF ILLINOIS  
DEPARTMENT OF PUBLIC WORKS & BUILDINGS  
DIVISION OF HIGHWAYS

ROUTE NO.	SECTION	COUNTY	TOTAL SHEETS	SHEET NO.	SHEET NO. 32 69 SHEETS
S. I. 53	531-2	COOK	67	37	
P. C. 46 - VHB		ILLINOIS		P. B. AIR PROJECT	

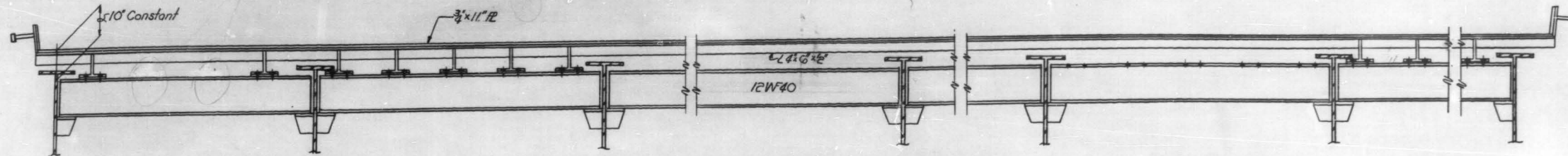

ELEVATION

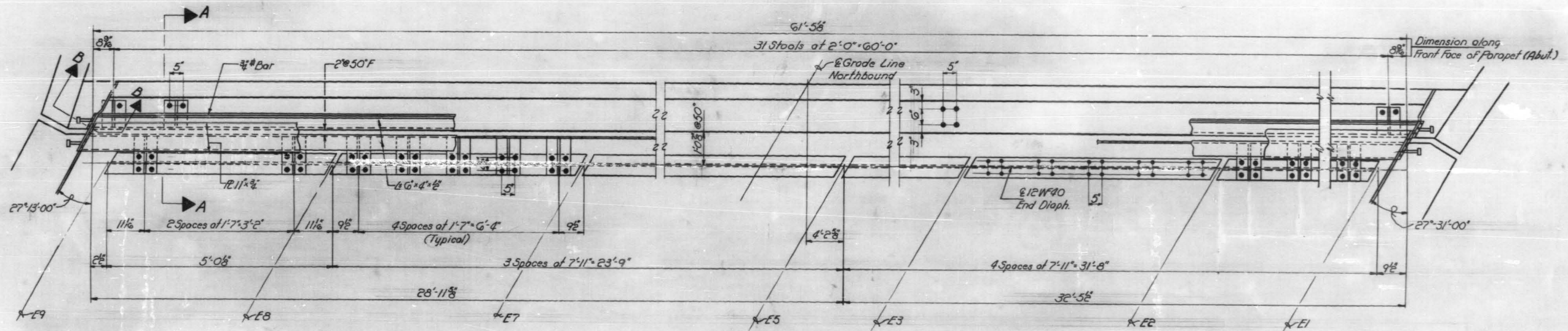

PLAN

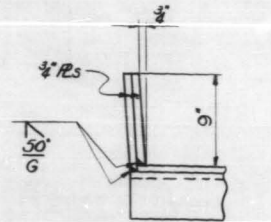

SECTION B-B

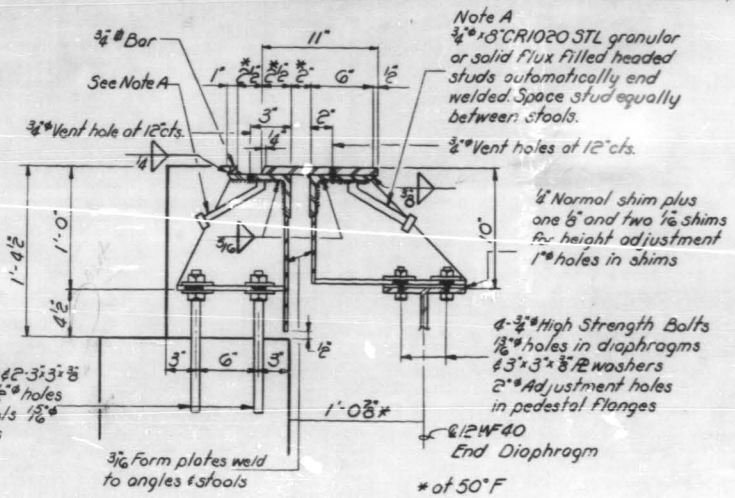

SECTION A-A

DESIGNED *Robby Chidran*  
CHECKED *James Hawking*  
DRAWN *W.E. Dickerson*  
CHECKED *J.W.*

EXAMINED *W.E. Dickerson*  
PASSED *Chidran*  
APPROVED *Chidran*  
CHIEF HIGHWAY ENGINEER

JUNE 16 1964

All stools cut from  $E \times W \times G \times B$  (1 Cuts 2)  
4- $\frac{3}{8}$ " x 1- $\frac{1}{8}$ " anchor bolts  $\frac{1}{2}$ " x  $\frac{3}{4}$ " x  $\frac{3}{8}$ "  
12 washers each bolt.  $\frac{1}{2}$ " holes for adjustment in stools.  $\frac{1}{2}$ " holes in plate washers

Note A  
 $\frac{3}{4}$ " x  $\frac{3}{8}$ " CR1020 STL granular or solid flux filled headed studs automatically end welded. Space stud equally between stools.  
 $\frac{3}{8}$ " Vent holes at 12" cts.

$\frac{1}{2}$ " Normal shim plus one  $\frac{1}{8}$ " and two  $\frac{1}{16}$ " shims for height adjustment.  $\frac{1}{8}$ " holes in shims

4- $\frac{3}{8}$ " High Strength Bolts  
 $\frac{1}{2}$ " holes in diaphragms  
 $\frac{1}{2}$ " x  $\frac{3}{4}$ " x  $\frac{3}{8}$ " washers  
2" Adjustment holes in pedestal flanges  
End Diaphragm  
\* of 50°F

EXPAN. DEVICE SO. ABUT-UNITE  
S. B. I. ROUTE 53  
SEC. 531-2-VHB  
COOK COUNTY  
STATION 270+71.7





STATE OF ILLINOIS  
DEPARTMENT OF PUBLIC WORKS & BUILDINGS  
DIVISION OF HIGHWAYS

ROUTE NO.	SECTION	COUNTY	TOTAL SHEETS	SHEET NO.
53	531-2	COOK	67	33
61	VHB			

SHEET NO. 33  
60 SHEETS

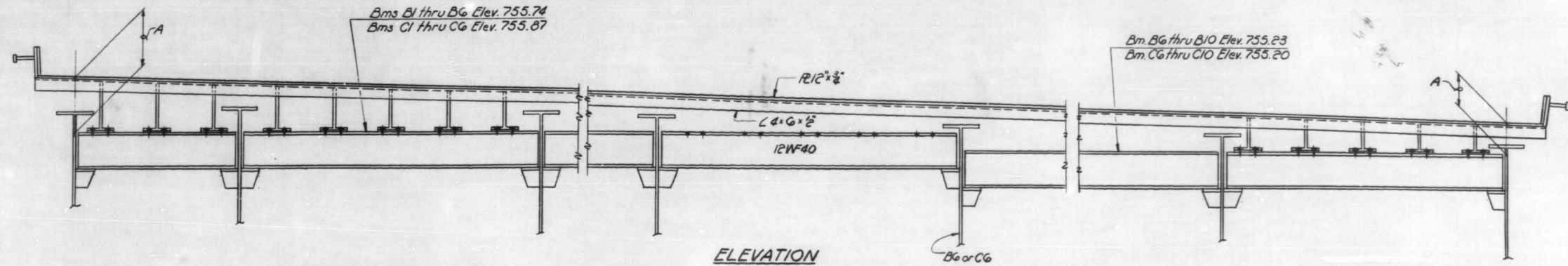

Beam	B1	B2	B3	B4	B5	B6	B7	B8	B9	B10
A	1'-3 3/8"	1'-2 5/8"	1'-1 3/8"	1'-0 3/8"	11 3/8"	10 5/8"	1'-4 5/8"	1'-3"	1'-1 3/8"	10 1/8"

Beam	C1	C2	C3	C4	C5	C6	C7	C8	C9	C10
A	1'-1 3/8"	1'-0 1/8"	11 1/8"	11"	10 1/4"	9 1/2"	1'-5 1/4"	1'-3 1/8"	1'-1 3/8"	1'-0 1/8"

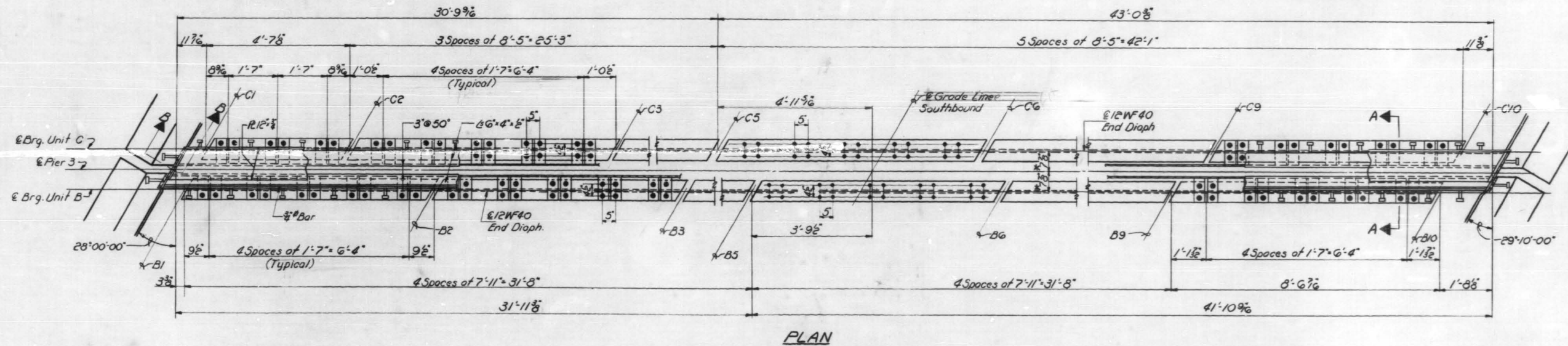

PLAN

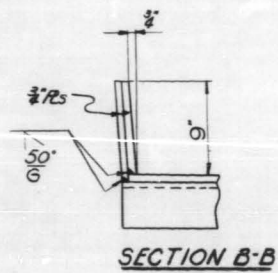

SECTION B-B

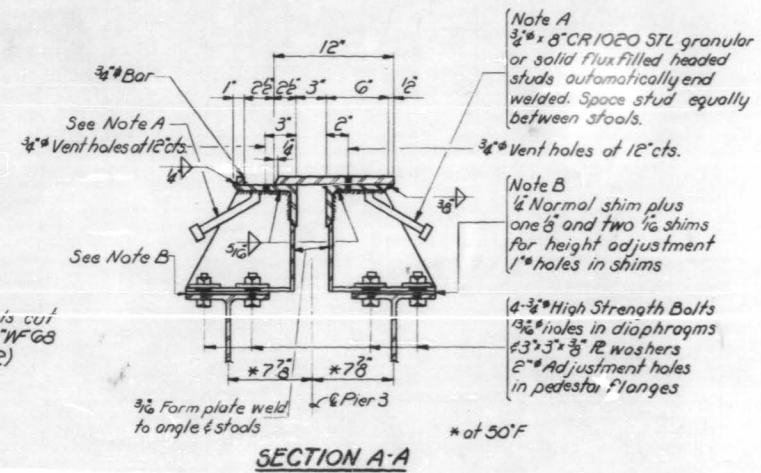

SECTION A-A

DESIGNED *Bobby Chilton*  
CHECKED *James Manning*  
DRAWN *W.E. Dickerson*  
CHECKED *J.W.*

EXAMINED *W.E. Baumann*  
PASSED *E. Smith*  
APPROVED *[Signature]*  
CHIEF HIGHWAY ENGINEER

JUNE 14 1914

EXPAN-DIVICE PIERS UNITS B+C  
S.B.I. ROUTE 53  
SEC. 531-2-VHB  
COOK COUNTY  
STATION 270+71.17



STATE OF ILLINOIS  
DEPARTMENT OF PUBLIC WORKS & BUILDINGS  
DIVISION OF HIGHWAYS

ROUTE NO.	SECTION	COUNTY	TOTAL SHEETS	SHEET NO.	SHEET NO. 34
53	531-2	COOK	67	39	60 SHEETS
P.A. 61	-VHB				
FED. ROAD DIST. NO. 7	ILLINOIS	FED. AID PROJECT			

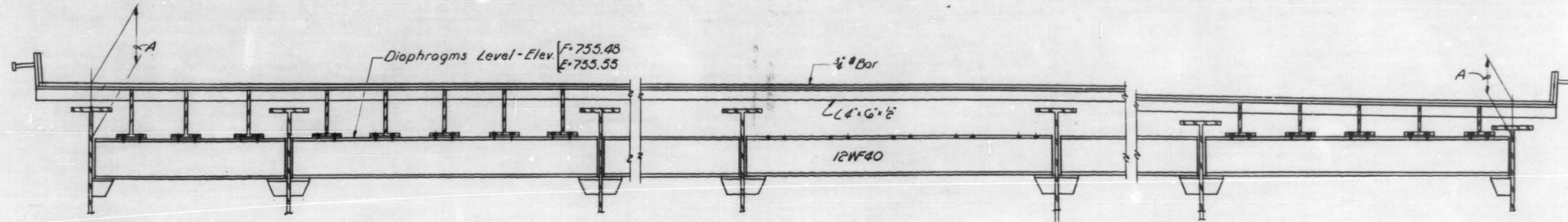

ELEVATION

Beam	E1	E2	E3	E4	E5	E6	E7	E8	E9
A	1'-3 3/8"	1'-2 3/8"	1'-2 1/2"	1'-2 1/4"	1'-2 5/8"	1'-2 5/8"	1'-0 7/8"	0'-10 3/8"	0'-9 1/4"

Beam	F1	F2	F3	F4	F5	F6	F7	F8	F9
A	1'-3 3/8"	1'-3 3/8"	1'-3 1/2"	1'-3"	1'-2 1/2"	1'-2 1/2"	1'-0 5/8"	0'-10 1/8"	0'-10 1/8"

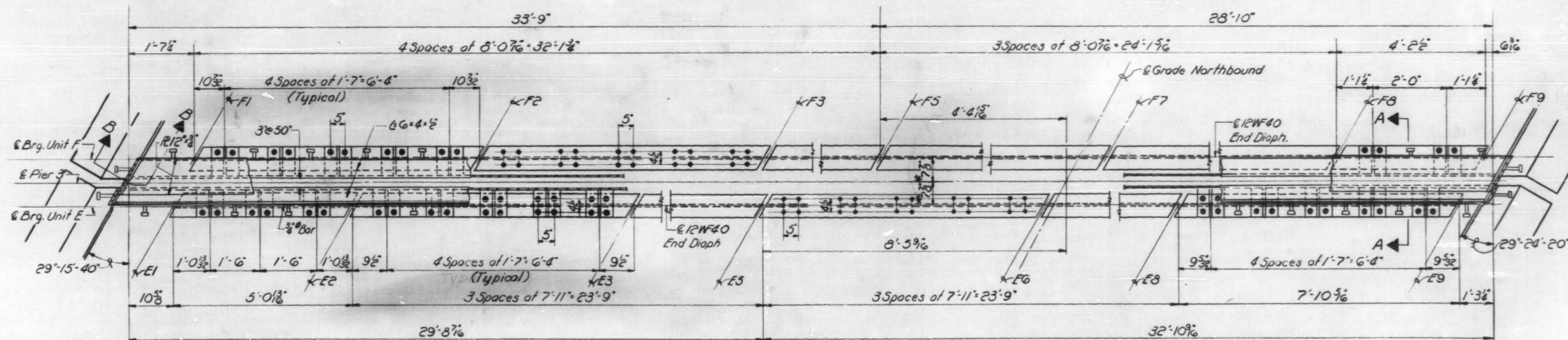

PLAN

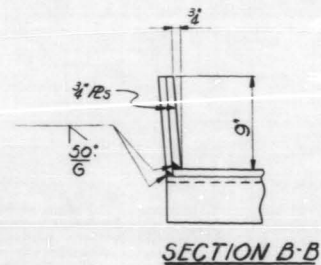

SECTION B-B

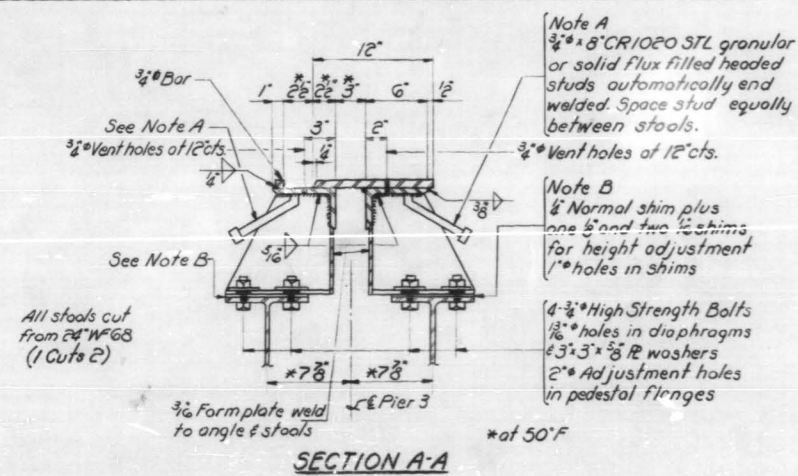

SECTION A-A

DESIGNED: *John Francis*  
CHECKED: *Bobby Chilton*  
DRAWN: *W. E. Dickerson*  
CHECKED: *B. C.*

EXAMINED: *W. E. Dickerson*  
PASSED: *Chilton*  
APPROVED: *W. E. Dickerson*  
JUNE 14 1964  
CHIEF HIGHWAY ENGINEER

EXPAN. DEVICE-PIER 3-UNITS E&F  
S.B.I. ROUTE 53  
SEC. 531-2-VHB  
COOK COUNTY  
STATION 270+71.17



STATE OF ILLINOIS  
DEPARTMENT OF PUBLIC WORKS & BUILDINGS  
DIVISION OF HIGHWAYS

ROUTE NO.	SECTION	COUNTY	TOTAL SHEETS	SHEET NO.	SHEET NO. 35
S. I. 53	531-2	COOK	67	40	60 SHEETS
P. A. 61	-VHB				
FED. ROAD DIST. NO. 7	ILLINOIS	FED. AID PROJECT			

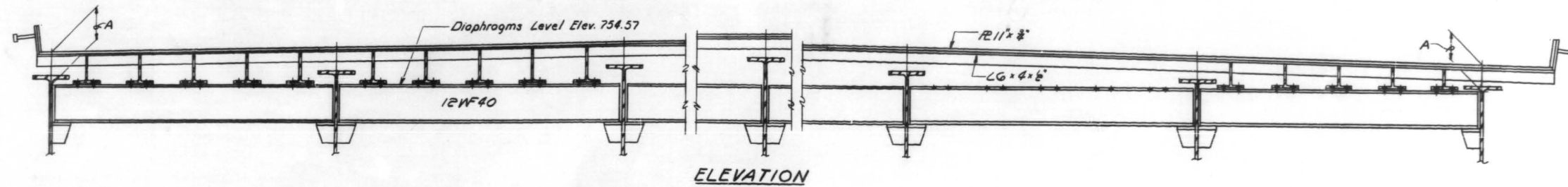

Beam	C1	C2	C3	C4	C5	C6	C7	C8	C9	C10
A	10'	11 3/4'	1'-1 3/8"	1'-2 3/8"	1'-4 1/2"	1'-4 1/2"	1'-2 3/8"	1'-0 6/8"	10'	7 1/2"

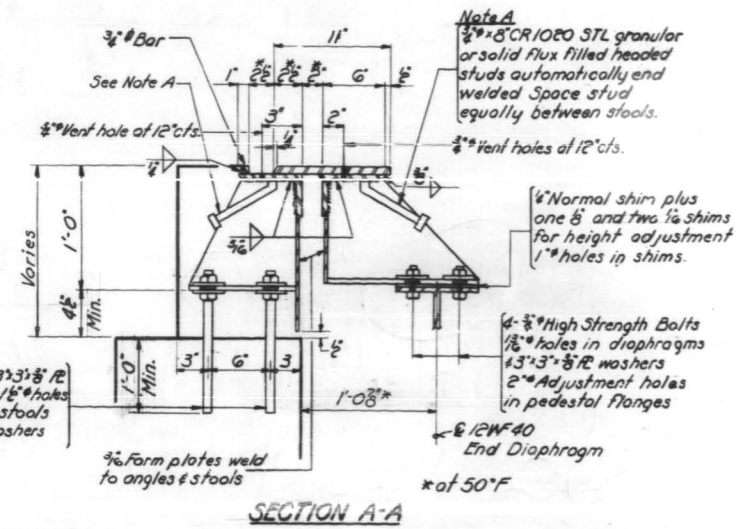
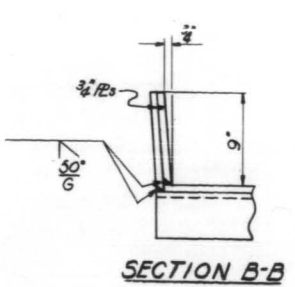
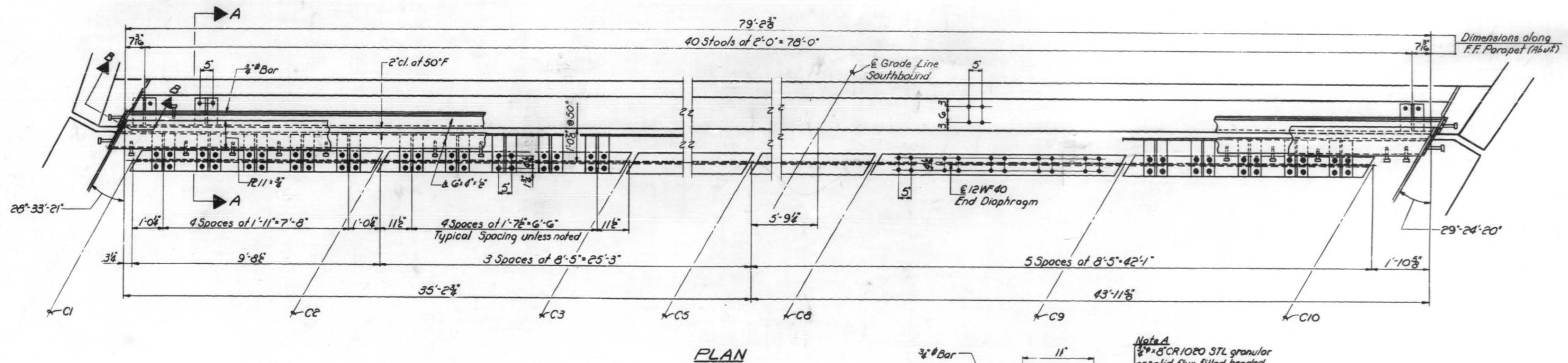

DESIGNED *Bobby Chilton*  
CHECKED *Toman Toman*  
DRAWN *W.E. Dickerson*  
CHECKED *GR*

EXAMINED *W.E. Dickerson*  
PASSED *Edmund*  
APPROVED *Edmund*

JUNE 16 1964

EXPAN. DEVICE-NQABUT-UNITC  
S.B.I. ROUTE 53  
SEC. 531-2-VHB  
COOK COUNTY  
STATION 270+71.17





STATE OF ILLINOIS  
DEPARTMENT OF PUBLIC WORKS & BUILDINGS  
DIVISION OF HIGHWAYS

ROUTE NO.	SECTION	COUNTY	TOTAL SHEETS	SHEET NO.	SHEET NO. 36 SHEETS
R.A. 53	531-2	COOK	67	41	
R.A. 61	VHB				
FED. ROAD DIST. NO. 7	ILLINOIS	FED. AID PROJECT			

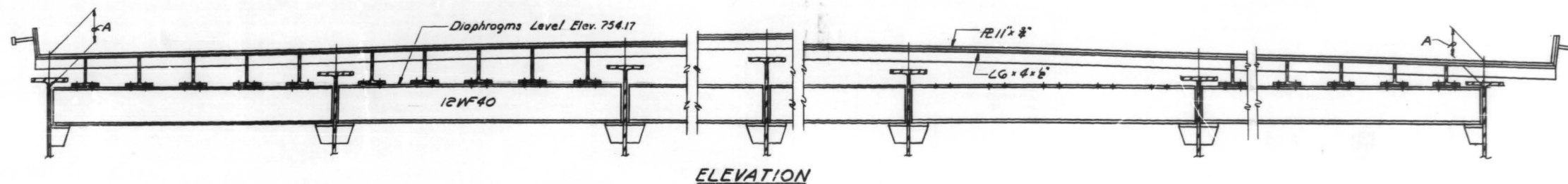

ELEVATION

Beam	F1	F2	F3	F4	F5	F6	F7	F8	F9
A	1'-0"	1'-1 1/2"	1'-2 1/2"	1'-4 1/2"	1'-5 3/8"	1'-5 3/8"	1'-3 3/8"	1'-1 1/2"	10 3/4"

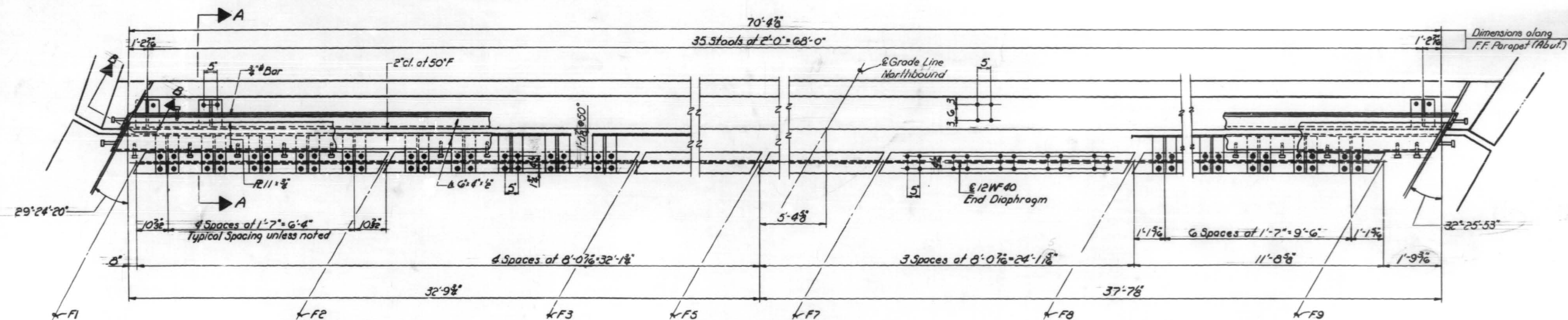

PLAN

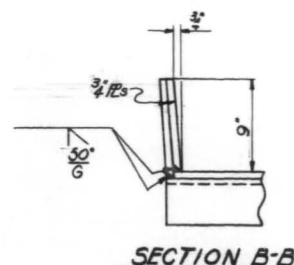

SECTION B-B

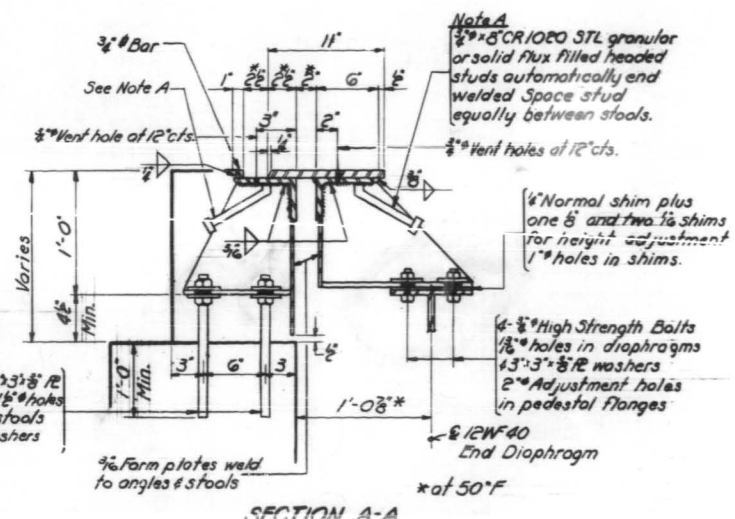

SECTION A-A

DESIGNED *Bobby Chilton*  
CHECKED *W. E. Dickerson*  
DRAWN *W. E. Dickerson*  
CHECKED *G.R.*

EXAMINED *H. B. Burmann*  
PASSED *E. H. ...*  
APPROVED *...*  
CHIEF HIGHWAY ENGINEER

JUNE 16 1964

EXPAN. DEVICE-NO. ABUT. UNIT F  
S.B.I. ROUTE 53  
SEC. 531-2-VHB  
COOK COUNTY  
STATION 270+71.17

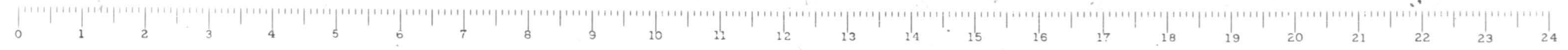

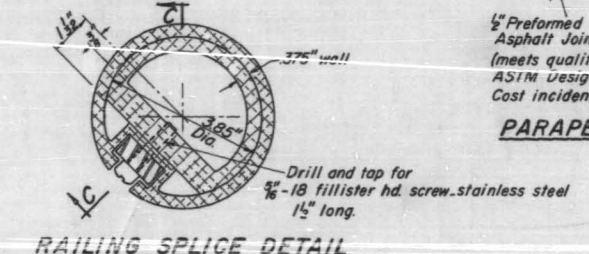
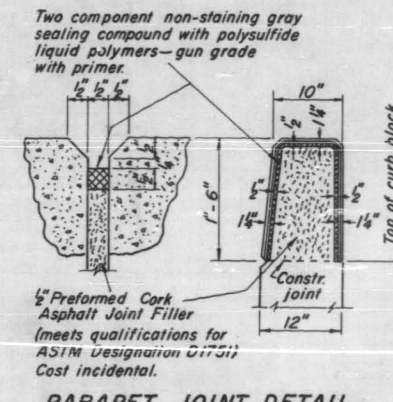
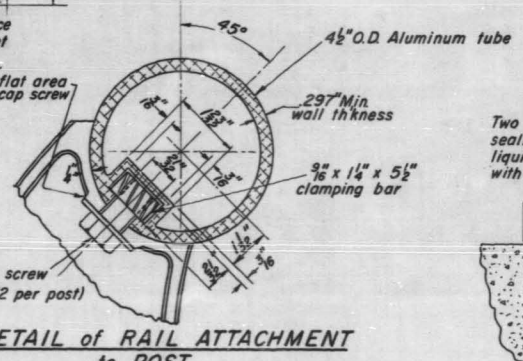
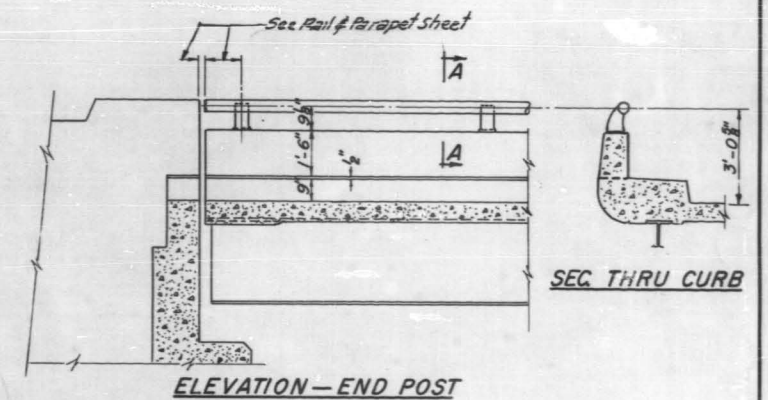
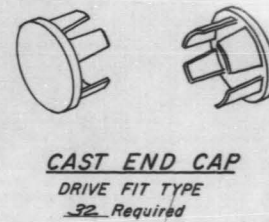
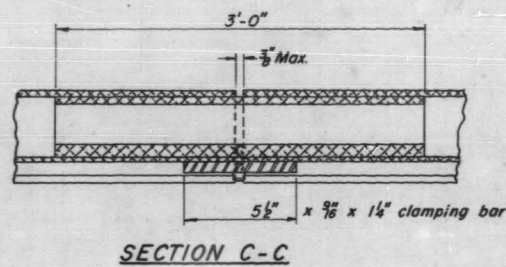
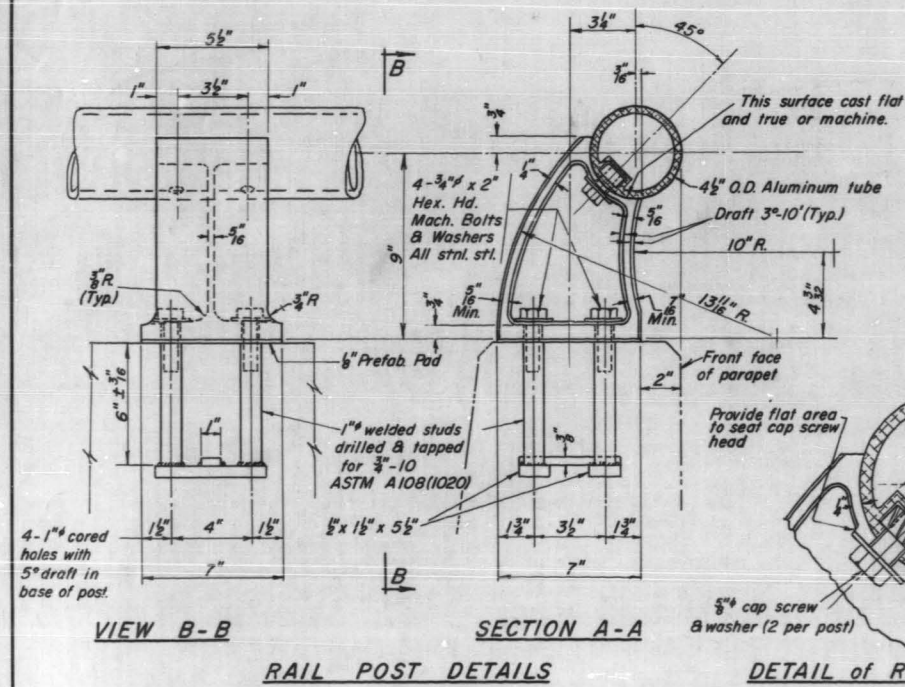

**NOTES:**  
All Posts shall be normal to parapet.  
All Aluminum Alloy Extruded Rail shall conform to ASTM specification B-235 alloy 6061-T6, or 6062-T6, and shall extend a minimum of 2 panel lengths (attached to a minimum of 3 posts) except at ends or at open joints where a minimum of 1 panel length is required. All joints in railing must be spliced per detail.  
See Special Provisions for following Material Specifications:  
Cast Aluminum Alloy Bridge Post Alloy 344-T4.  
Stainless Steel Machine Bolts, Washers, and Bars.  
For material composition of Prefabricated Pad, see Article 54.9(f), (Bearing and Anchorage), of the Standard Specifications.  
**METHOD of MEASUREMENT:** Aluminum handrail shall be measured in lineal feet. The length paid for shall be the over all length along the top longitudinal railing member thru all posts and gaps.  
**BASIS of PAYMENT:** Aluminum handrail shall be paid for at the contract unit price per lineal foot for ALUMINUM HANDRAIL, measured as specified, which price shall be payment in full for all materials, fabrication, transportation, and erection.  
Cost of rail splice, end caps, and hardware to be incidental to item ALUMINUM HANDRAIL.

**BILL of MATERIAL**

Item	Unit	Quantity
ALUMINUM HANDRAIL	Lin Ft	2,052

**ALUMINUM HANDRAIL**  
**S.B.I. ROUTE 53**  
**SEC. 531-2-VHB**  
**COOK COUNTY**  
**STATION 270+71.17**

DESIGNED	None	16	1964
CHECKED	W.S. Reinmann		
DRAWN	Wm. M. Best		
CHECKED			

R-19 Dwn. 6-26-64





STATE OF ILLINOIS  
DEPARTMENT OF PUBLIC WORKS & BUILDINGS  
DIVISION OF HIGHWAYS

ROUTE NO.	SECTION	COUNTY	TOTAL SHEETS	SHEET NO.
S.B.I. 53	531-2	COOK	67	42
P.A. 61	-VHB			
FED. ROAD DIST. NO. 7		SLURRIES	FED. AID PROJECT	

SHEET NO. 37  
60 SHEETS

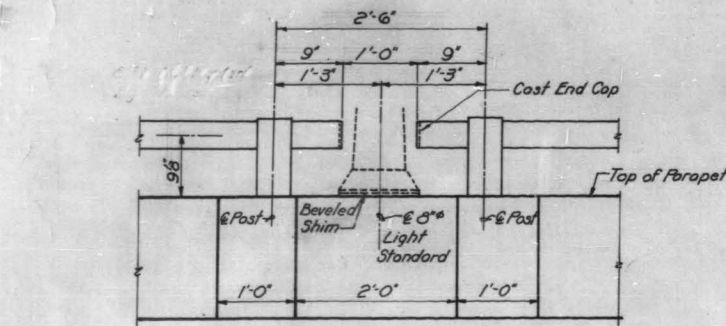

NOTE:  
All 6 3/8" Light Standards  
and shims as required  
by others

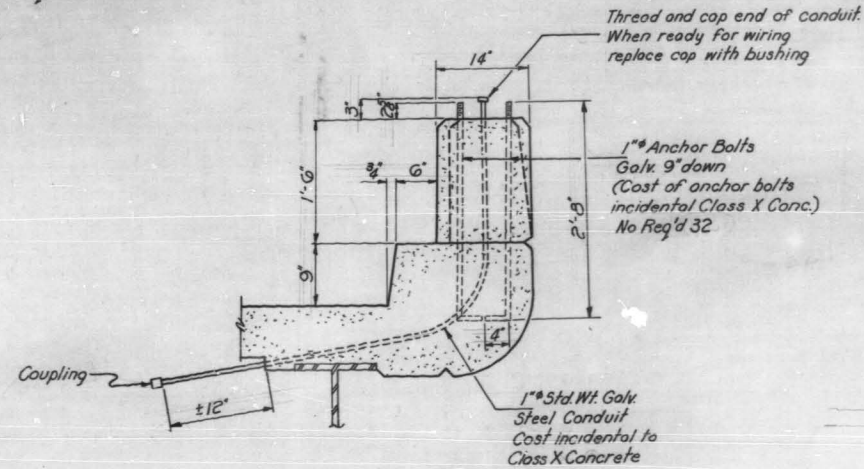

NOTE: SEE SHEET 41A FOR RAIL POST DETAILS.

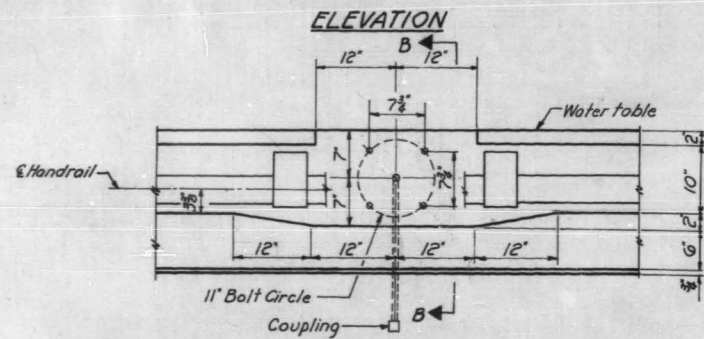

PLAN  
DETAILS OF PARAPET  
AT LIGHT STANDARD

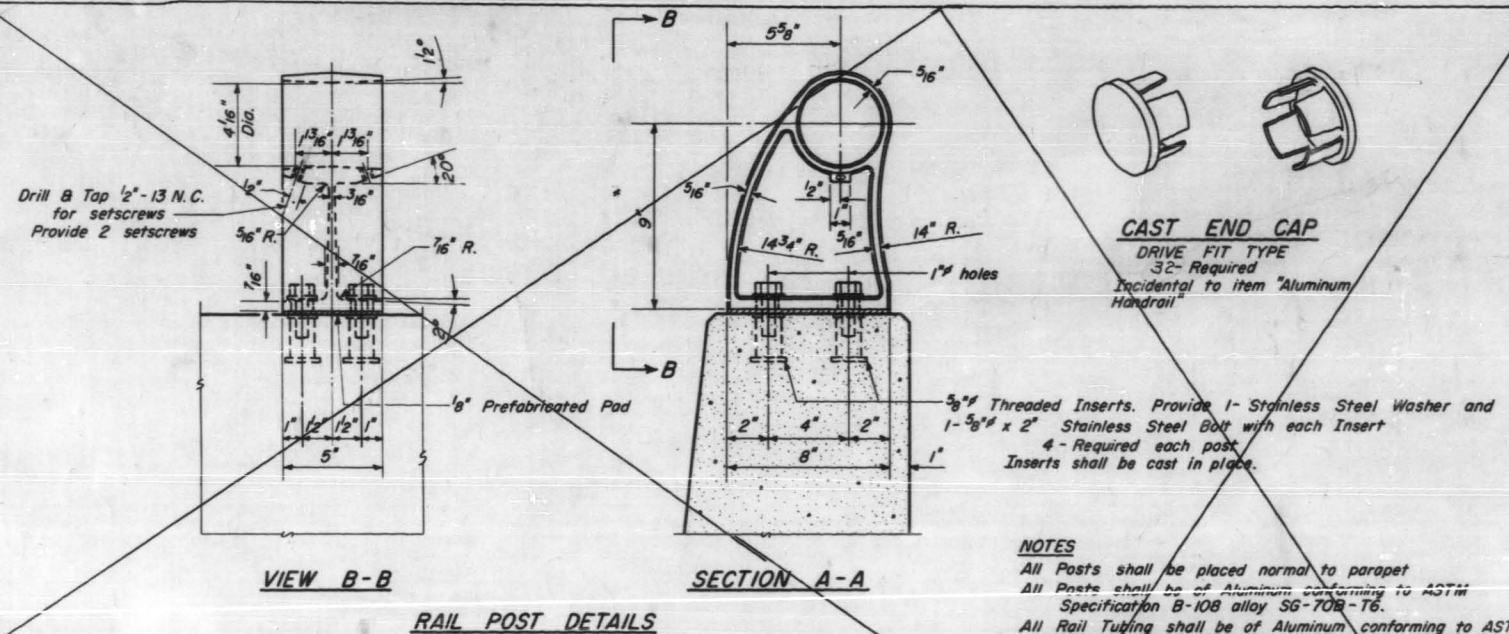

**NOTES**  
All Posts shall be placed normal to parapet  
All Posts shall be of Aluminum conforming to ASTM Specification B-108 alloy 56-708-T6.  
All Rail Tubing shall be of Aluminum conforming to ASTM Specification B-235 alloy 6061-T6 or 6062-T6.  
Aluminum handrail shall be measured in lineal feet. The length paid for shall be the overall length along the top longitudinal railing member through all post and gaps.  
Rail tubing may extend a maximum of 3 panel lengths.  
For material composition of Prefabricated Pad, See Art. 54.9 (f), (Bearings and Anchorage), of the Std. Specs.  
Set Screws shall be of Aluminum conforming to ASTM Specification B-211 alloy 2024-T4.  
Aluminum handrail will be paid for at the contract unit price per lineal foot for ALUMINUM HANDRAIL, measured as specified, which price shall be payment in full for all materials, fabrication, transportation and erection.

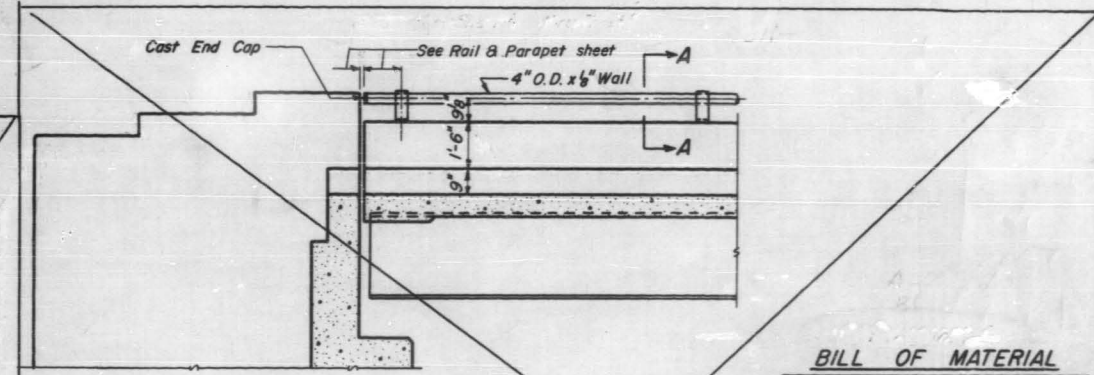

ELEVATION - END POST

**BILL OF MATERIAL**

Item	Unit	Quantity
Aluminum Handrail	Lin. Ft.	2,052

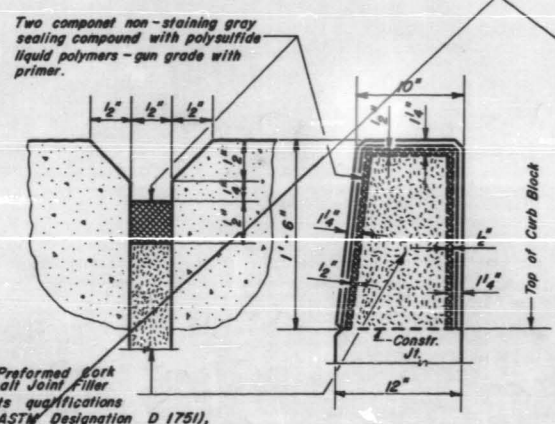

PARAPET JOINT DETAIL  
(See other sheets for location)

**RAIL & LIGHT STANDARD DETAILS**  
S.B.I. ROUTE 53  
SEC. 531-2-VHB  
COOK COUNTY  
STATION 270+71.7

DESIGNED *Bobby Chilton*  
CHECKED *James Hawkins*  
DRAWN *W. A. Sausaman*  
CHECKED *B.C.* *J.W.*

EXAMINED *W. B. Bauman*  
PASSED *E. H. ...*  
APPROVED *...*

JUNE 16 1964

R-10 Drawn 2-16-60 Rev. 11-2-62 Rev. 7-17-63



STATE OF ILLINOIS  
DEPARTMENT OF PUBLIC WORKS & BUILDINGS  
DIVISION OF HIGHWAYS  
208'-5 1/2"

ROUTE NO.	SECTION	COUNTY	TOTAL SHEETS	SHEET NO.
S. I. 53	531-2	COOK	67	43
P. A. 41	-VHB			
FED. ROAD DIST. NO. 7	ILLINOIS	FED. AID PROJECT		

SHEET NO. 38  
60 SHEETS

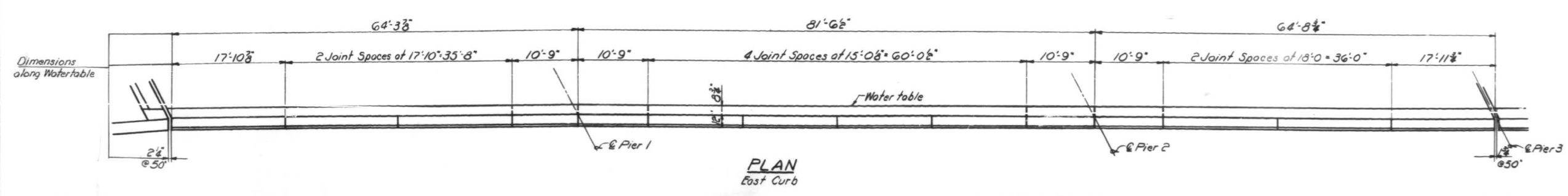
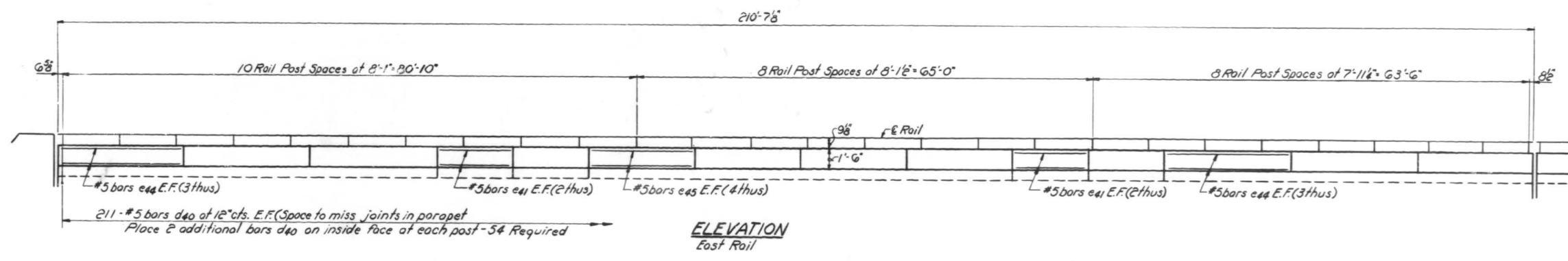
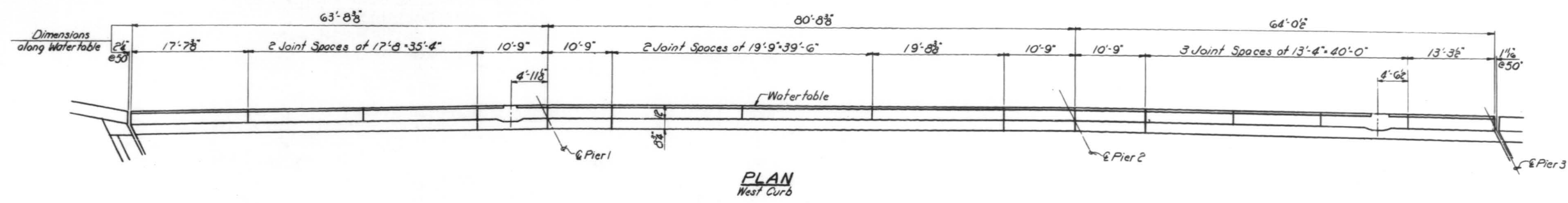
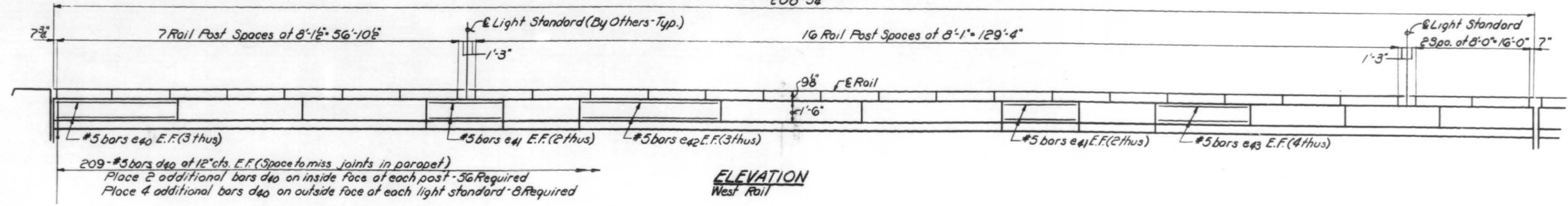

DESIGNED *Bobby Chilton*  
CHECKED *James Waring*  
DRAWN *W.E. Dickerson*  
CHECKED *B.C.*

JUNE 16 1964  
EXAMINED *W.E. Dickerson*  
PASSED *Sherry*  
APPROVED *[Signature]*

For details of rail, parapet & light standard see sh. #37

**BILL OF REINFORCEMENT**

Bar	No.	Size	Length	Shape
e40	12	#5	17'-5"	
e41	32	#5	10'-6"	
e42	12	#5	19'-5"	
e43	16	#5	13'-0"	
e44	24	#5	17'-8"	
e45	16	#5	14'-9"	

**RAIL & PARAPET - UNIT B**  
S.B.I. ROUTE 53  
SEC. 531-2-VHB  
COOK COUNTY  
STATION 270+71.17





STATE OF ILLINOIS  
DEPARTMENT OF PUBLIC WORKS & BUILDINGS  
DIVISION OF HIGHWAYS

ROUTE NO.	SECTION	COUNTY	TOTAL SHEETS	SHEET NO.	SHEET NO. 39 60 SHEETS
53	531-2	COOK	67	44	
P.A. 41 - VHB		ILLINOIS	FED. AID PROJECT		

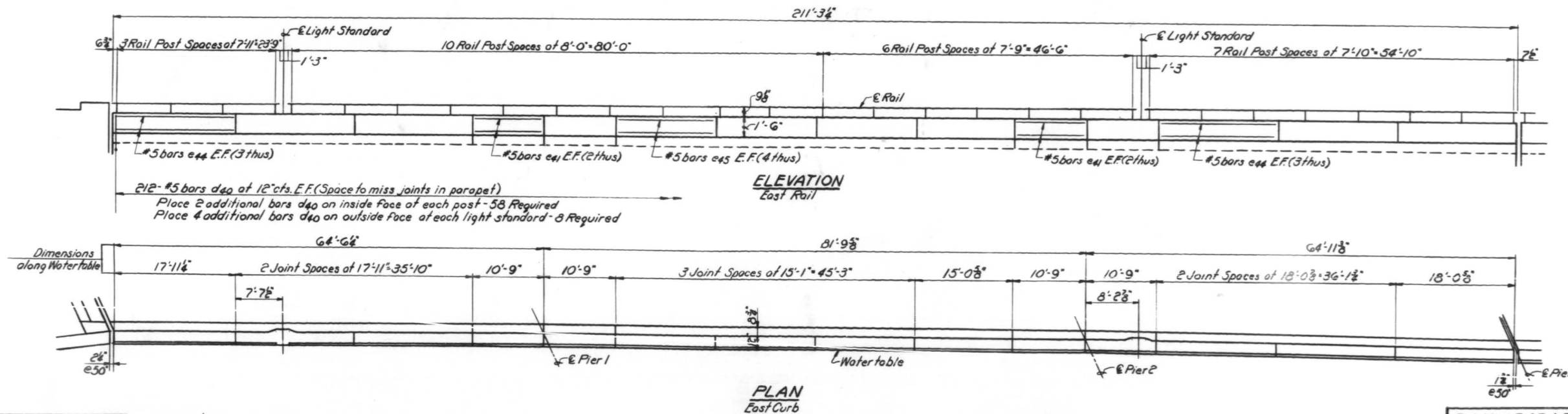
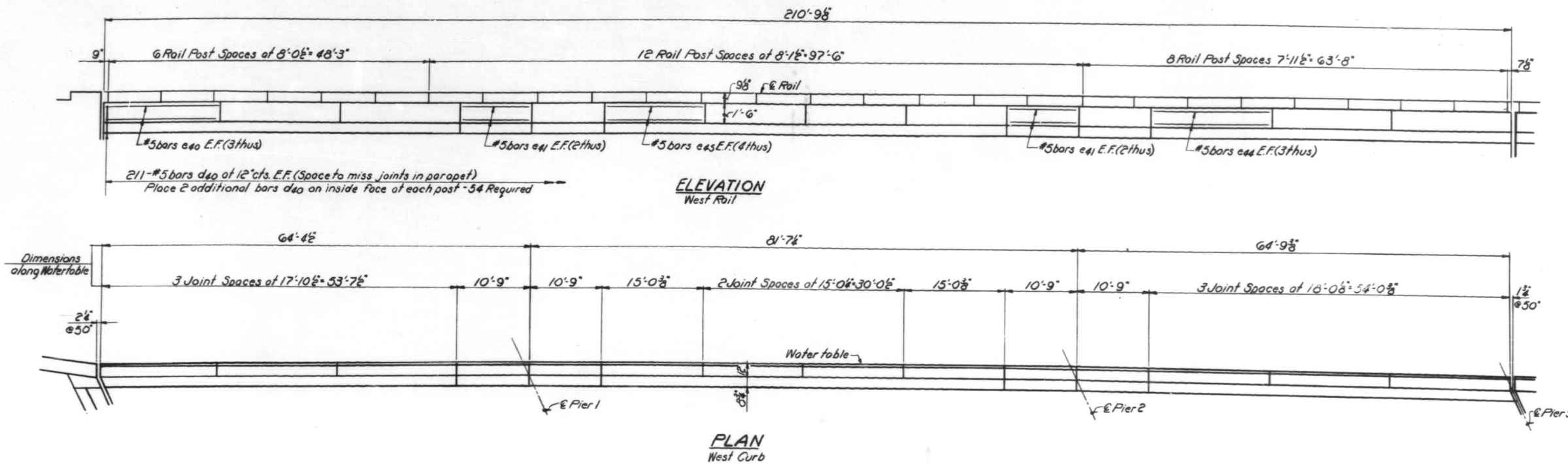

DESIGNED *Bobby Chilton*  
CHECKED *James Hanning*  
DRAWN *W.E. Dickerson*  
CHECKED *R.C.*

JUNE 16 1964  
EXAMINED *W.E. Busmann*  
PASSED *Shultz*  
APPROVED *[Signature]*

For details of rail, parapet & light standard see sh. # 37

**BILL OF REINFORCEMENT**

Bar	No.	Size	Length	Shape
e40	12	#5	17'-5"	---
e41	32	#5	10'-6"	---
e44	36	#5	17'-8"	---
e45	32	#5	14'-9"	---

**RAIL & PARAPET - UNIT E**  
S.B.I. ROUTE 53  
SEC. 531-2-VHB  
COOK COUNTY  
STATION 270+71.17



STATE OF ILLINOIS  
DEPARTMENT OF PUBLIC WORKS & BUILDINGS  
DIVISION OF HIGHWAYS

ROUTE NO.	SECTION	COUNTY	TOTAL SHEETS	SHEET NO.
S.B.I. 53	531-2-VHB	COOK	67	45
P.A. 61	-VHB			
FED. ROAD DIST. NO. 1	ILLINOIS	FED. AID PROJECT		

SHEET NO. 40  
60 SHEETS

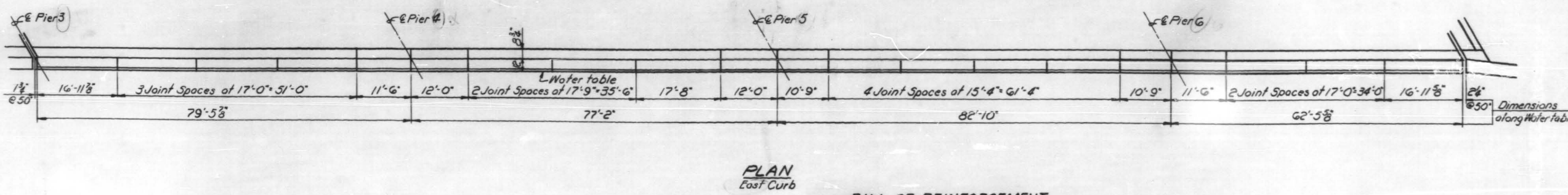
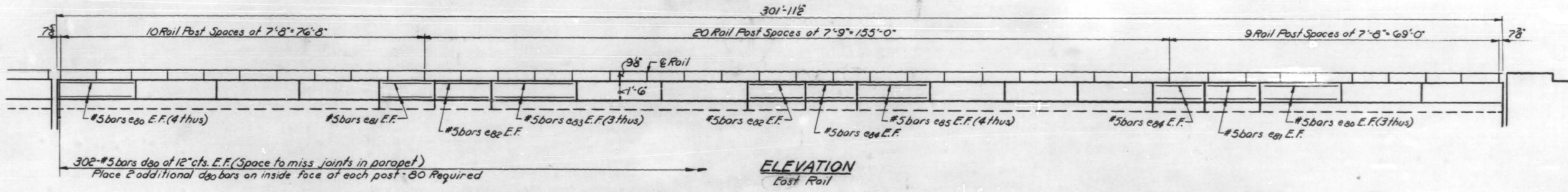
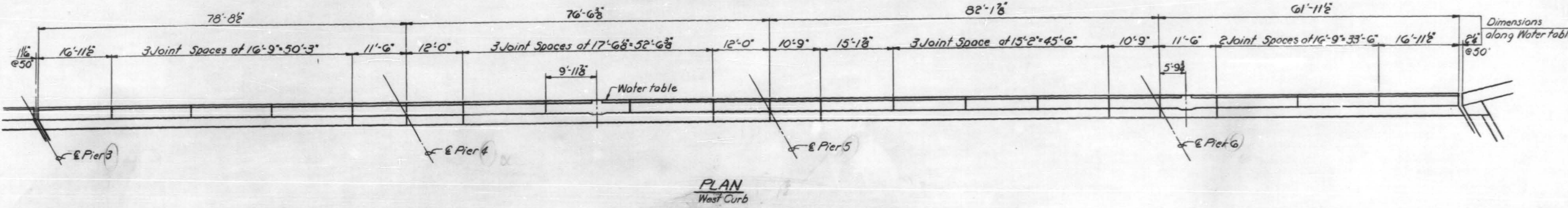
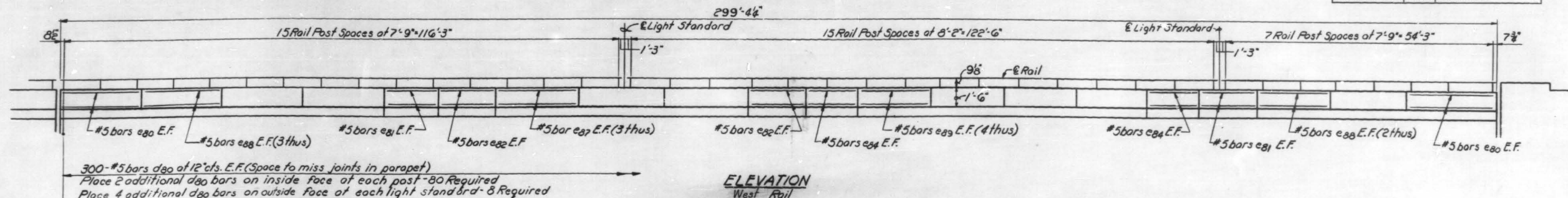

**BILL OF REINFORCEMENT**

Bar	No.	Size	Length	Shape
e80	36	#5	16'-8"	—
e81	16	#5	11'-3"	—
e82	16	#5	11'-9"	—
e83	12	#5	17'-6"	—
e84	16	#5	10'-6"	—
e85	16	#5	15'-1"	—
e87	12	#5	17'-3"	—
e88	20	#5	16'-6"	—
e89	16	#5	14'-11"	—

DESIGNED: *Bobby Chilton*  
CHECKED: *J. J. Waring*  
DRAWN: *W.E. Dickerson*  
CHECKED: *B.C.*

EXAMINED: *W.E. Baumann*  
PASSED: *Edwards*  
APPROVED: *[Signature]*

JUNE 16 1964

MEMBER OF DESIGN

CHIEF HIGHWAY DIVISION

For detail of rail, parapet & light standard see sh. #37

**RAIL & PARAPET-UNIT C**  
S.B.I. ROUTE 53  
SEC. 531-2-VHB  
COOK COUNTY  
STATION 270+71.17

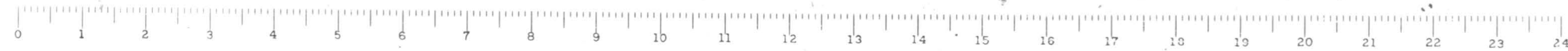



STATE OF ILLINOIS  
DEPARTMENT OF PUBLIC WORKS & BUILDINGS  
DIVISION OF HIGHWAYS  
301'-11 3/8"

ROUTE NO.	SECTION	COUNTY	TOTAL SHEETS	SHEET NO.	SHEET NO.
S. B. I. 53	531-2	COOK	67	46	60 SHEETS
F. A. 61	-VHB				
FED. ROAD DIST. NO. 7	ILLINOIS	FED. AID PROJECT			

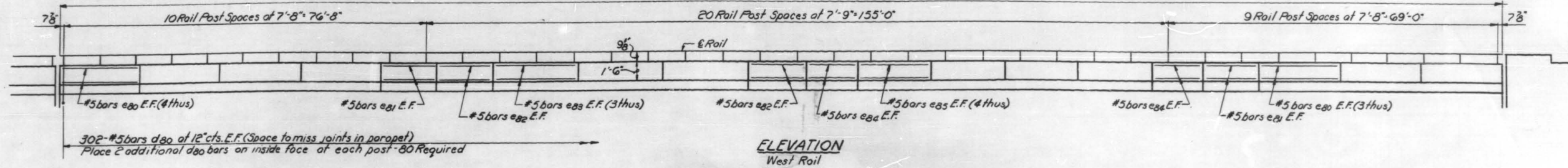

ELEVATION  
West Rail

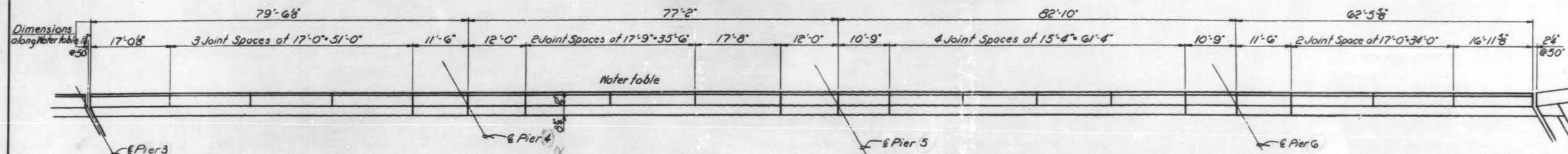

PLAN  
West Curb

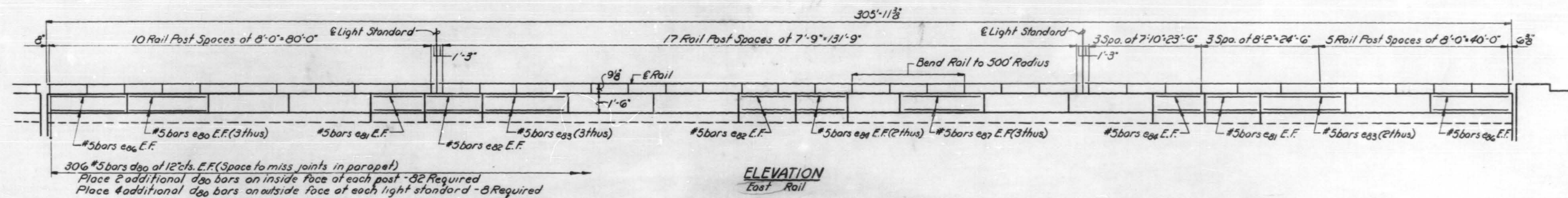

ELEVATION  
East Rail

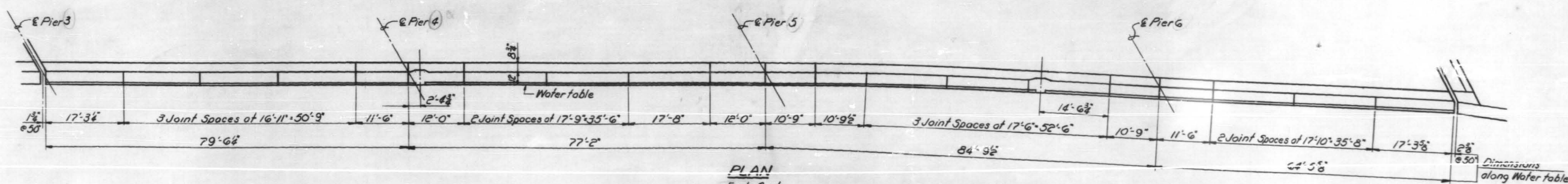

PLAN  
East Curb

BILL OF REINFORCEMENT

Bar	No.	Size	Length	Shape
e80	40	#5	16'-8"	---
e81	16	#5	11'-3"	---
e82	16	#5	11'-9"	---
e83	32	#5	17'-6"	---
e84	20	#5	10'-6"	---
e85	16	#5	15'-1"	---
e86	8	#5	17'-0"	---
e87	12	#5	17'-3"	---

DESIGNED *W. E. Dickerson*  
CHECKED *J. J. W...*  
DRAWN *W. E. Dickerson*  
CHECKED *B. C.*

EXAMINED *W. E. Dickerson*  
PASSED *...*  
APPROVED *...*

JUNE 16 1964

For details of rail, parapet & light standard see Sh #37

RAIL & PARAPET-UNIT F  
S. B. I. ROUTE 53  
SEC. 531-2-VHB  
COOK COUNTY  
STATION 270+71.7





STATE OF ILLINOIS  
DEPARTMENT OF PUBLIC WORKS & BUILDINGS  
DIVISION OF HIGHWAYS

ROUTE NO.	SECTION	COUNTY	TOTAL SHEETS	SHEET NO.
53	531-2	COOK	67	47
A.A. - 61 - VHB		60 SHEETS		
ILLINOIS		FED. AID PROJECT		

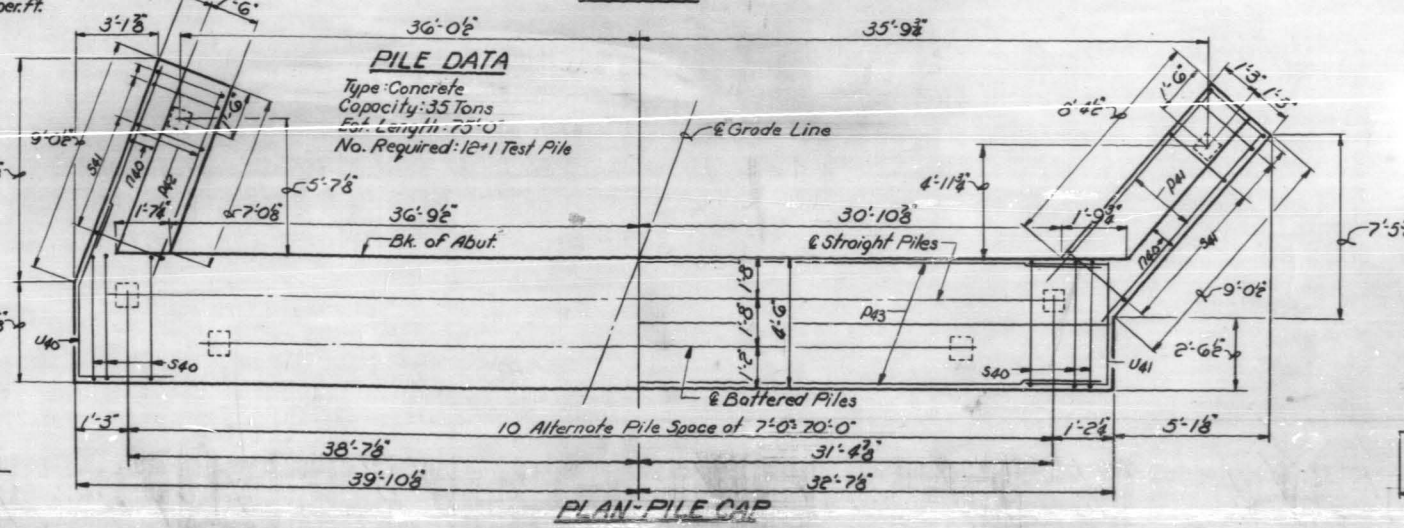
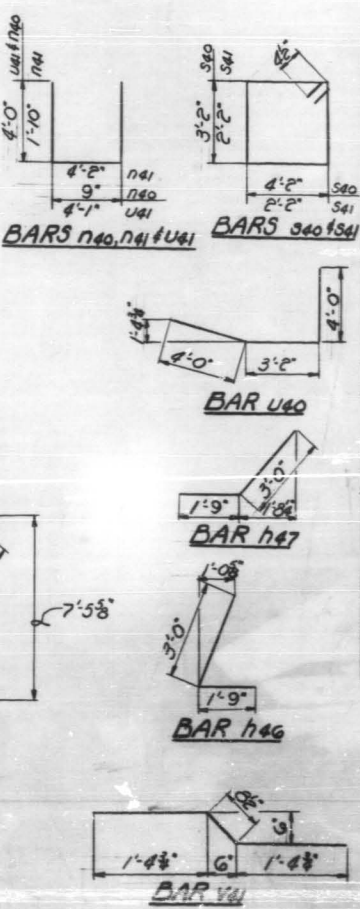
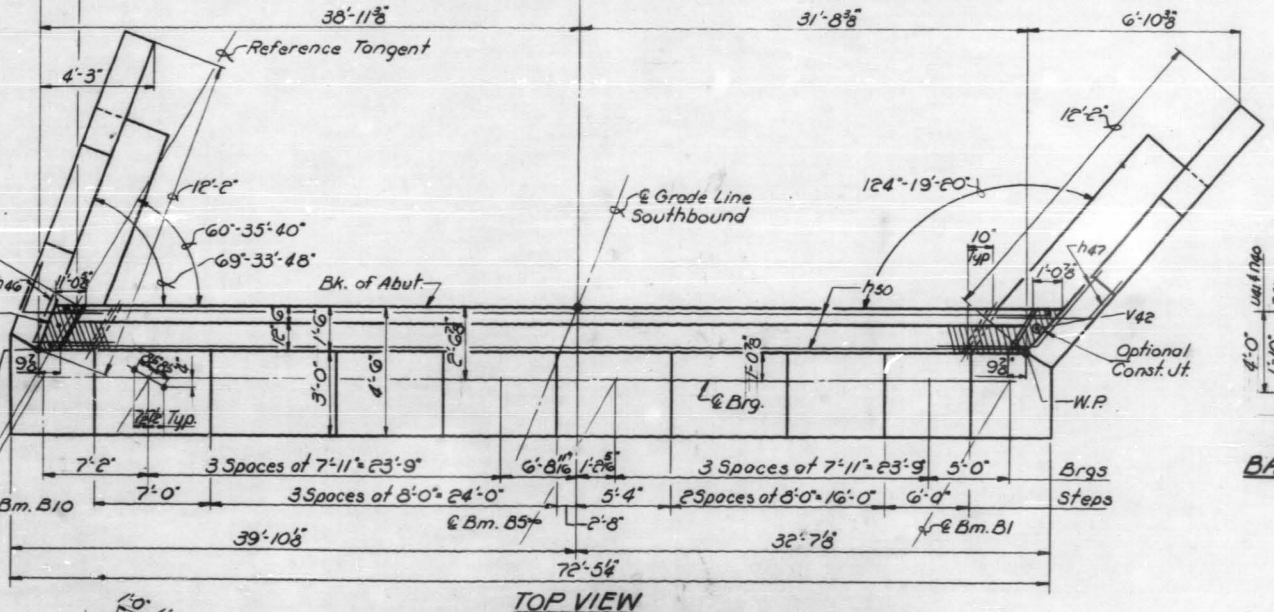
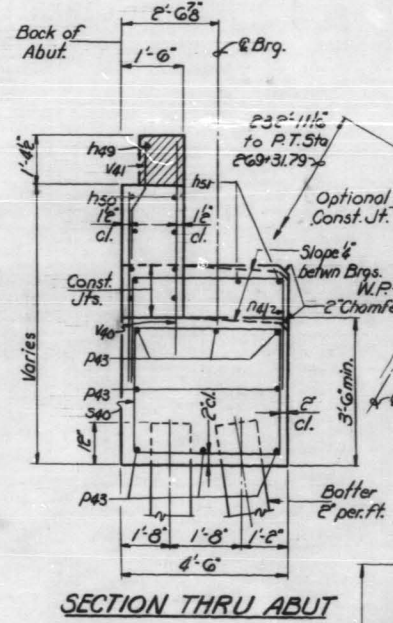
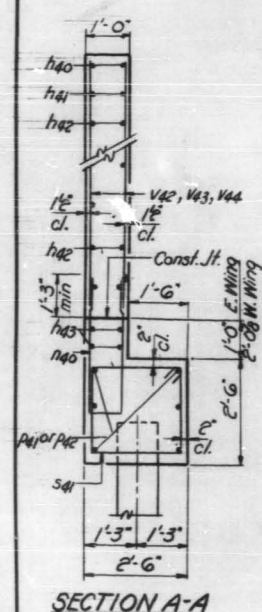
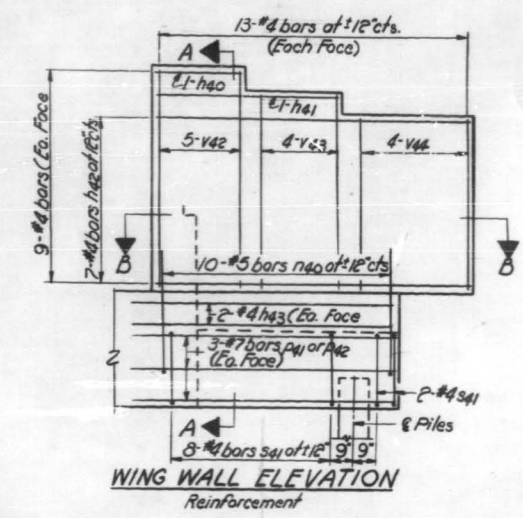
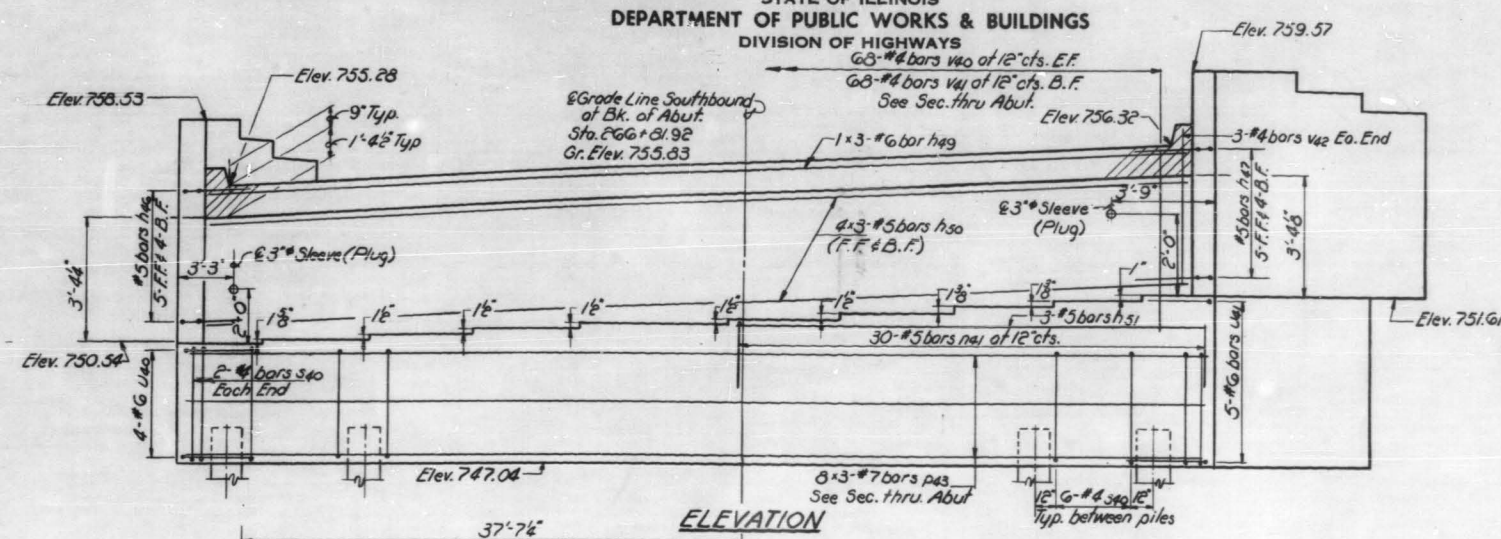
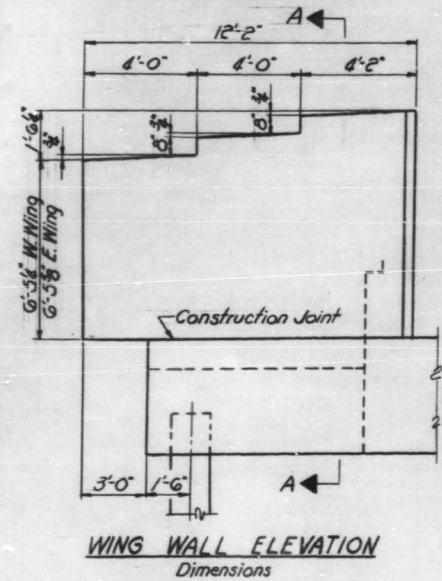

DESIGNED *Bobby Chilton*  
CHECKED *J. M. Pines*  
DRAWN *W.E. Dickerson*  
CHECKED *J.W. J.N.P.*

EXAMINED *W.E. Dickerson*  
PASSED *Chilton*  
APPROVED *Chilton*

**SOUTH ABUTMENT UNIT B**  
S.B.I. ROUTE 53  
SEC. 531-2-VHB  
COOK COUNTY  
STATION 270+71.7





STATE OF ILLINOIS  
DEPARTMENT OF PUBLIC WORKS & BUILDINGS  
DIVISION OF HIGHWAYS

ROUTE NO.	SECTION	COUNTY	TOTAL SHEETS	SHEET NO.
A.S. 53	531-2	COOK	67	48
P.A. 61	VHB			

60 SHEETS

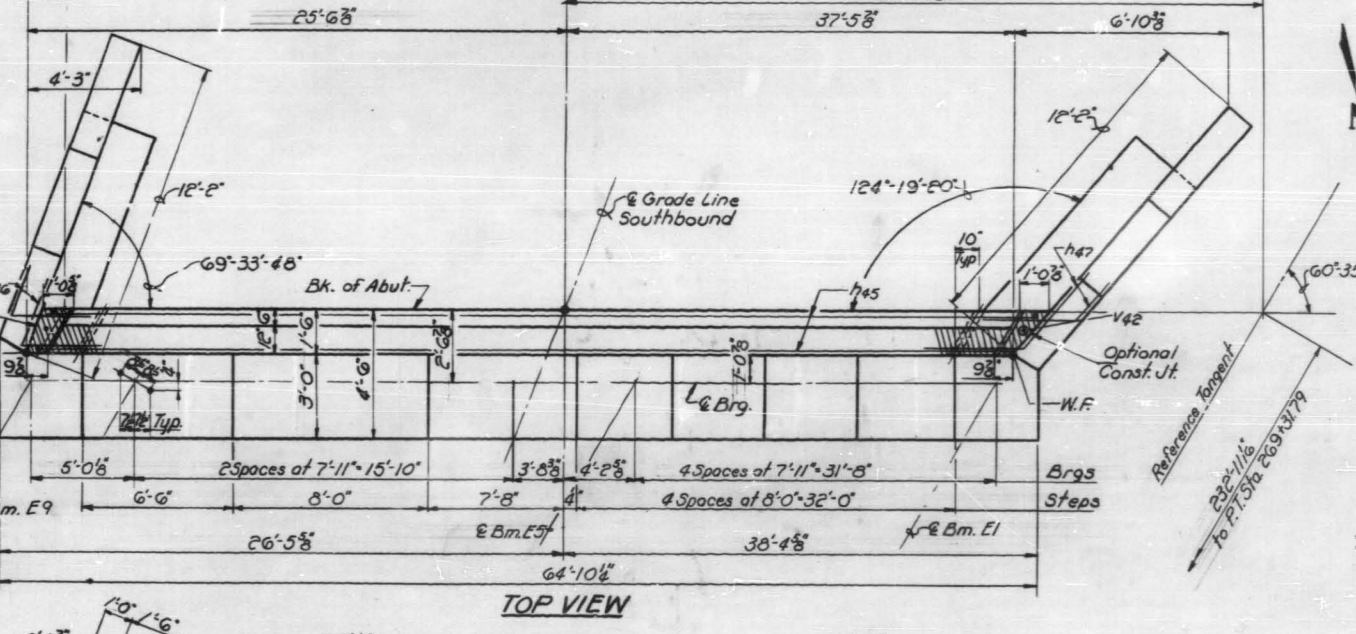
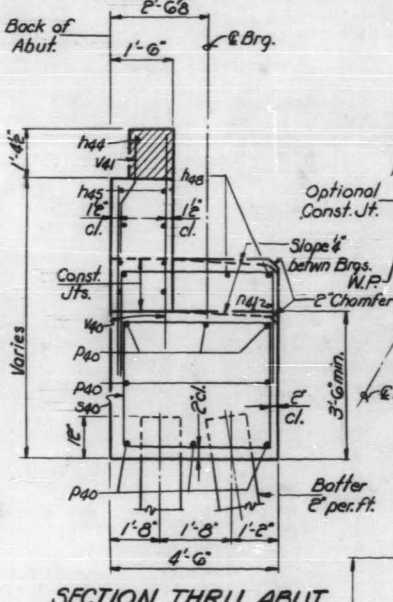
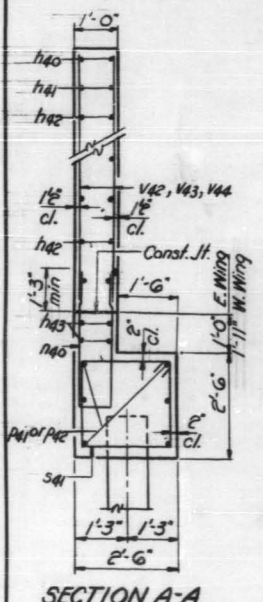
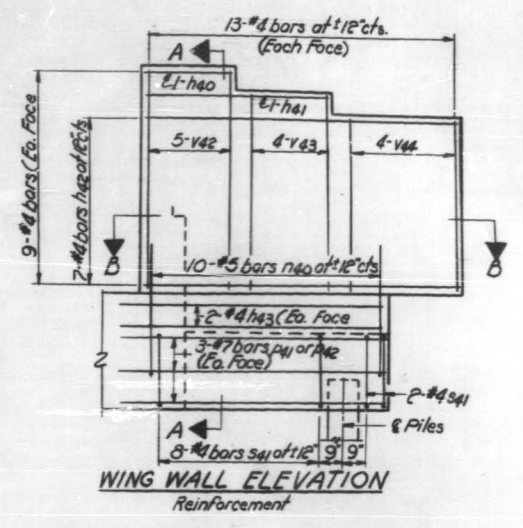
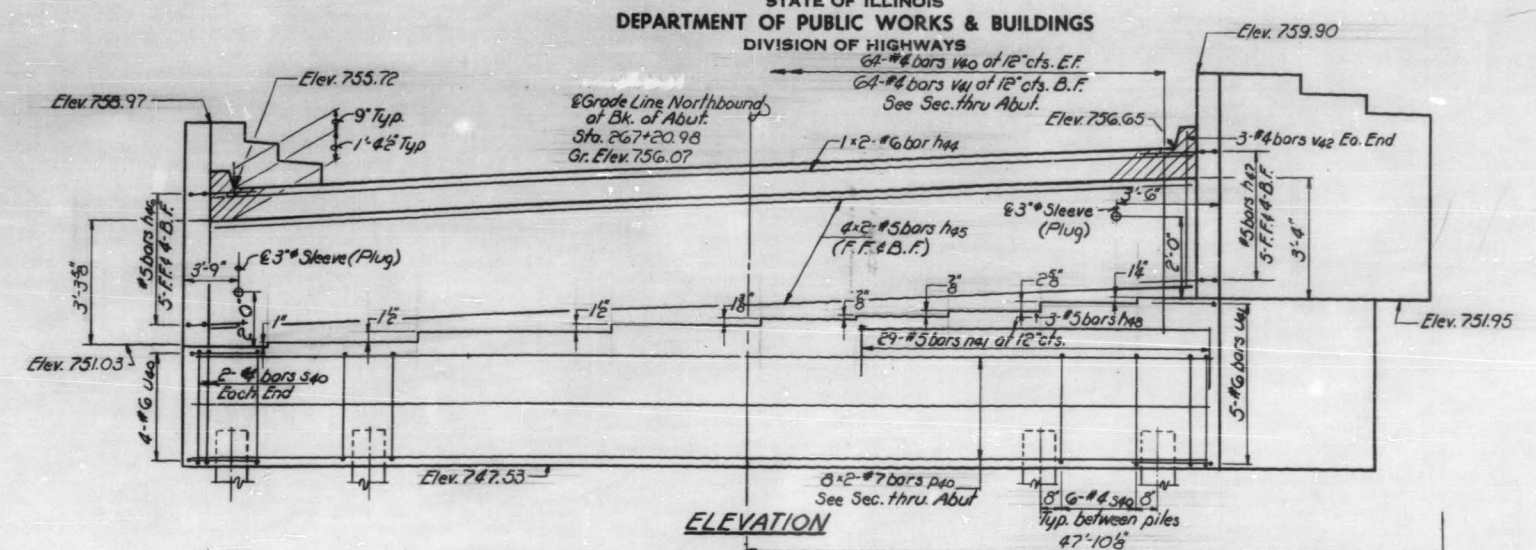
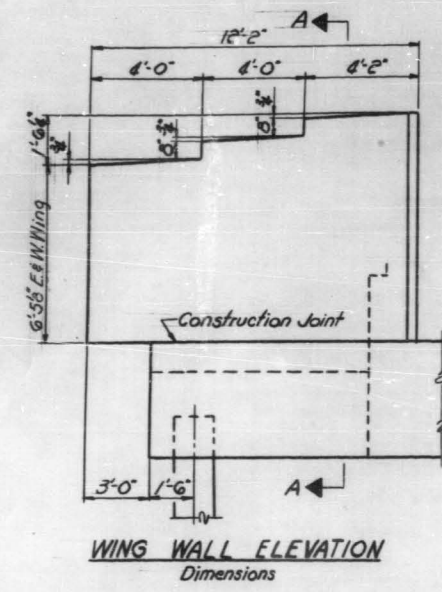

**BILL OF MATERIAL**

Bar	No.	Size	Length	Shape
h40	4	#4	3'-9"	
h41	4	#4	7'-9"	
h42	28	#4	11'-9"	
h43	8	#4	11'-0"	
h44	2	#6	32'-3"	
h45	16	#5	32'-3"	
h46	9	#5	4'-9"	
h47	9	#5	4'-9"	
h48	3	#5	29'-0"	
h49	20	#5	8'-9"	
h50	29	#5	7'-10"	
h51	16	#7	33'-0"	
h52	6	#7	10'-3"	
h53	6	#7	8'-9"	
h54	64	#4	15'-5"	
h55	20	#4	9'-5"	
h56	4	#6	1'-2"	
h57	5	#6	12'-1"	
h58	128	#4	6'-6"	
h59	64	#4	3'-6"	
h60	26	#4	7'-8"	
h61	16	#4	7'-0"	
h62	16	#4	6'-2"	
Class X Concrete		Cu. Yds.	65.4	
Reinforcement Bars		Lbs.	4780	
Concrete Pile		Vin FF	900	
Test Piles (Conc.)		Co.	One	

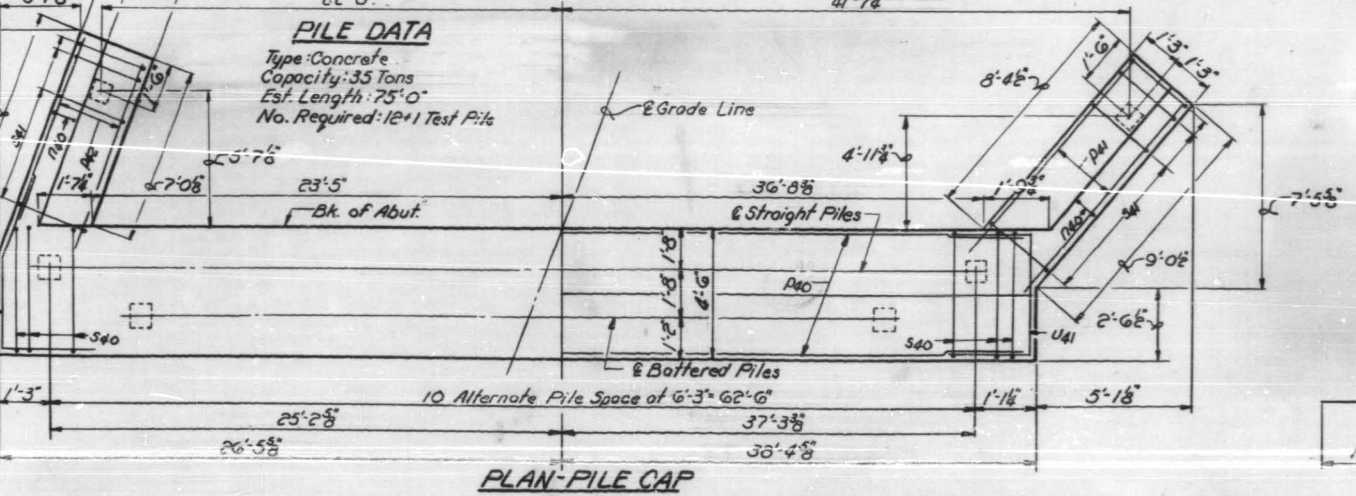

DESIGNED *Bobby Chilton*  
CHECKED *James W. Herring*  
DRAWN *W.E. Dickerson*  
CHECKED *J.N.P.*

JUNE 16 1964  
EXAMINED *W.B. Baumgartner*  
PASSED *Chilton*  
APPROVED *J.N.P.*

**SOUTH ABUTMENT-UNIT E**  
S.B.I. ROUTE 53  
SEC. 531-2-VHB  
COOK COUNTY  
STATION 270+71.17





STATE OF ILLINOIS  
DEPARTMENT OF PUBLIC WORKS & BUILDINGS  
DIVISION OF HIGHWAYS

ROUTE NO.	SECTION	COUNTY	TOTAL SHEETS	SHEET NO.
S. I. 53	531-2	COOK	67	49
P.A. 61	-VHB			
SHEET NO. 44 60 SHEETS				

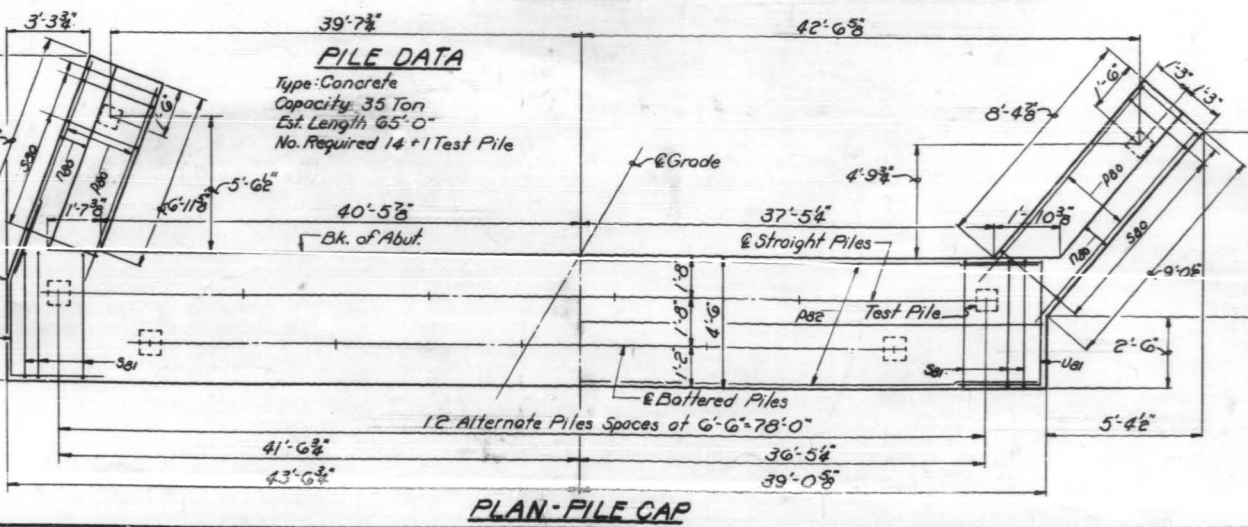
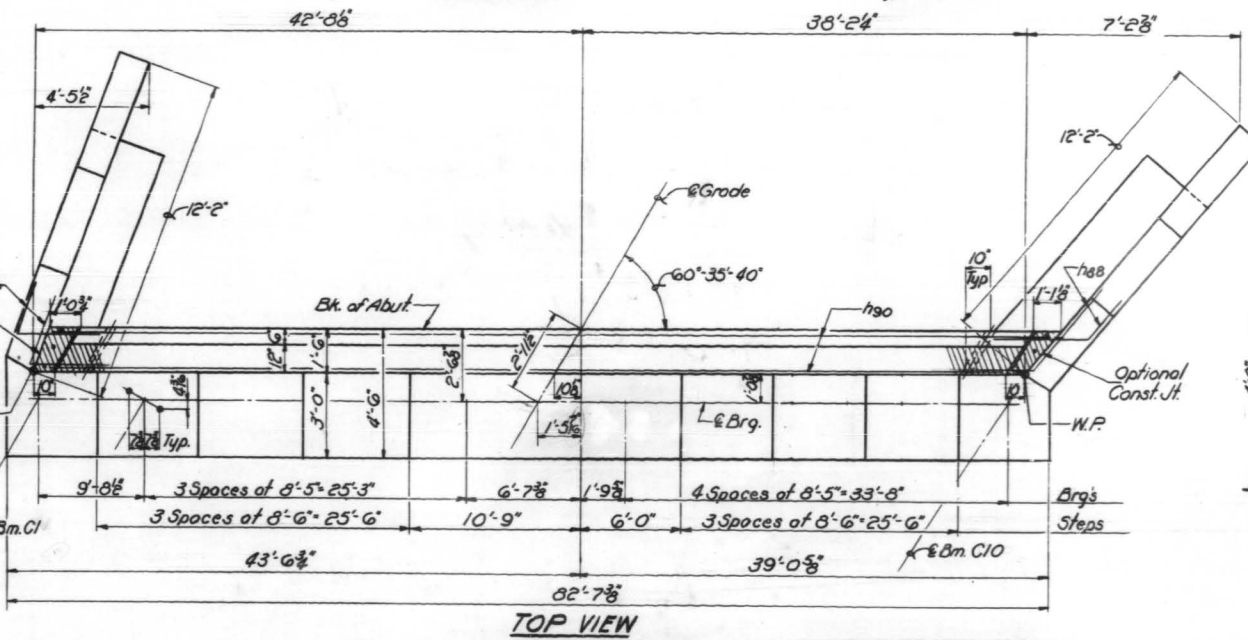
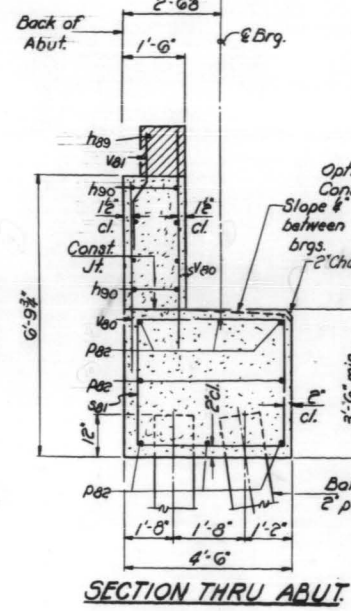
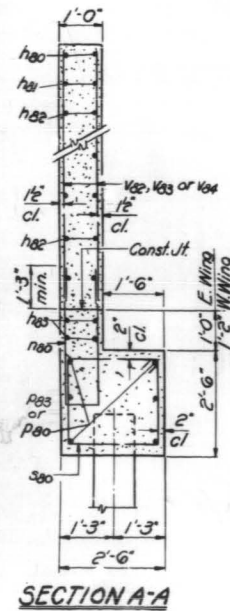
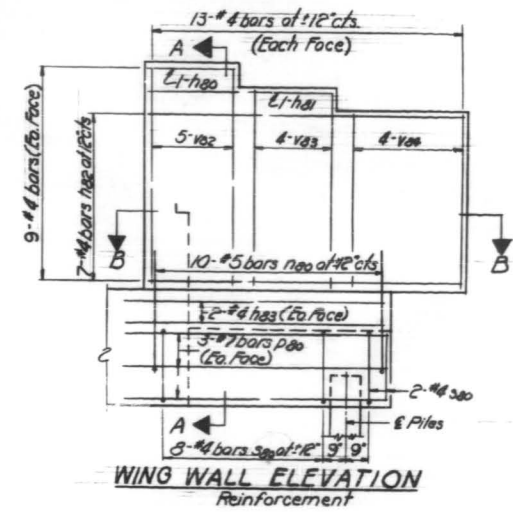
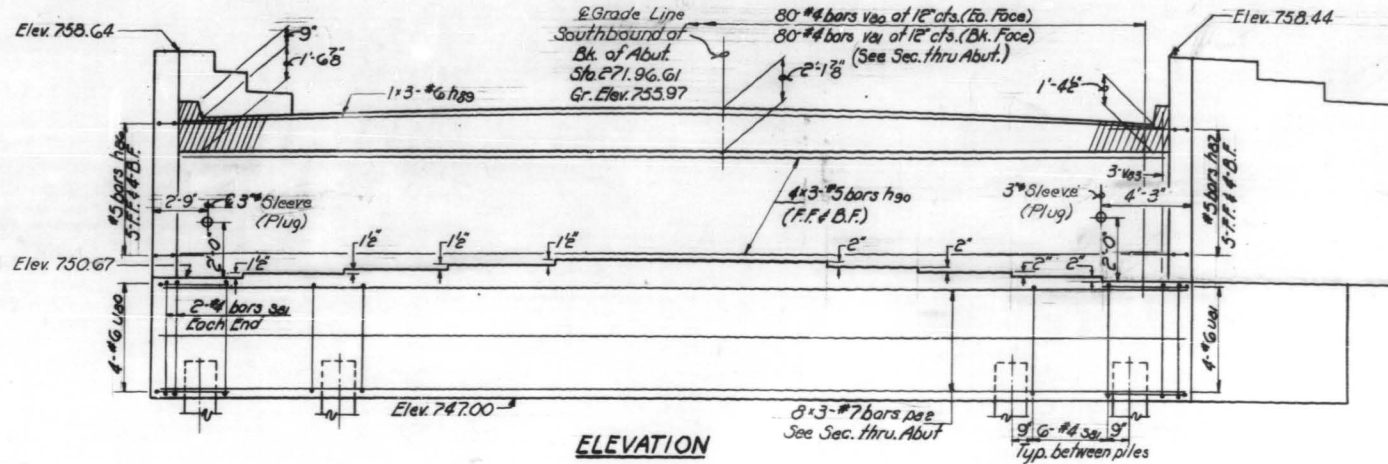
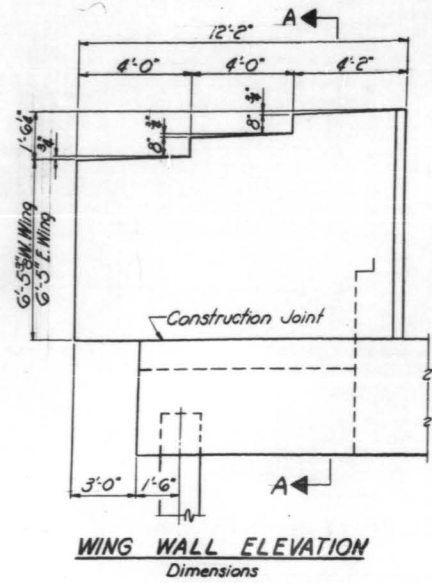

**PILE DATA**  
Type: Concrete  
Capacity: 35 Ton  
Est. Length: 65'-0"  
No. Required: 14 + 1 Test Pile

**SECTION B-B**  
**BILL OF MATERIAL**

Bar	No.	Size	Length	Shape
h80	4	#4	3'-9"	
h81	4	#4	7'-9"	
h82	28	#4	11'-9"	
h83	8	#4	11'-0"	
h84	5	#5	4'-9"	
h85	9	#5	4'-9"	
h89	3	#6	28'-0"	
h90	24	#5	28'-0"	
neo	20	#5	8'-9"	U
peo	6	#7	10'-3"	
pb2	24	#7	28'-6"	
pb3	6	#7	8'-9"	
sb0	20	#4	9'-5"	□
sb1	76	#4	15'-5"	□
u80	4	#6	10'-9"	
u81	4	#6	12'-1"	
v80	160	#4	5'-9"	
v81	80	#4	8'-6"	
v82	20	#4	7'-8"	
v83	22	#4	7'-0"	
v84	16	#4	6'-2"	
Class X Concrete				Cu. Yds. 773
Reinforcement Bars				Lbs. 5210
Concrete Piles				Lin. Ft. 910
Test Pile (Conc.)				Eq. 1

DESIGNED: *Torrey P. Pincus*  
CHECKED: *Bobby Chilton*  
DRAWN: *W.E. Dickerson*  
CHECKED: *B.C.*

EXAMINED: *W.E. Pincus*  
PASSED: *Chilton*  
APPROVED: *Chilton*

JUNE 14 1964

**NORTH ABUTMENT-UNIT C**  
S. B. I. ROUTE 53  
SEC. 531-2-VHB  
COOK COUNTY  
STATION 270+71.17





STATE OF ILLINOIS  
DEPARTMENT OF PUBLIC WORKS & BUILDINGS  
DIVISION OF HIGHWAYS

ROUTE NO.	SECTION	COUNTY	TOTAL SHEETS	SHEET NO.
S. B. I. 53	531-2	COOK	67	50
P. A. 41	-VHB			

SHEET NO. 45  
60 SHEETS

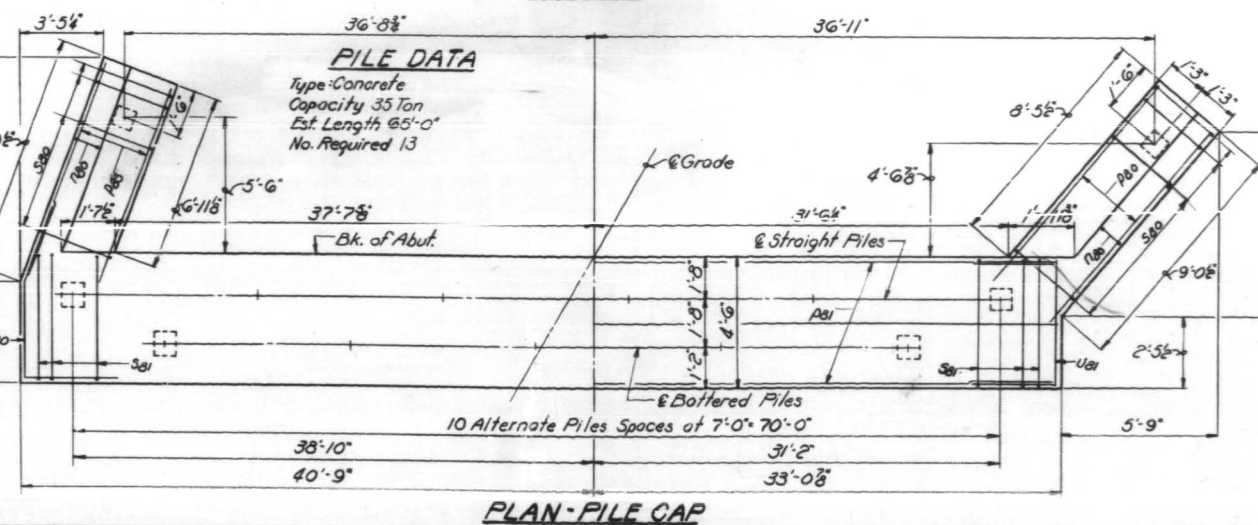
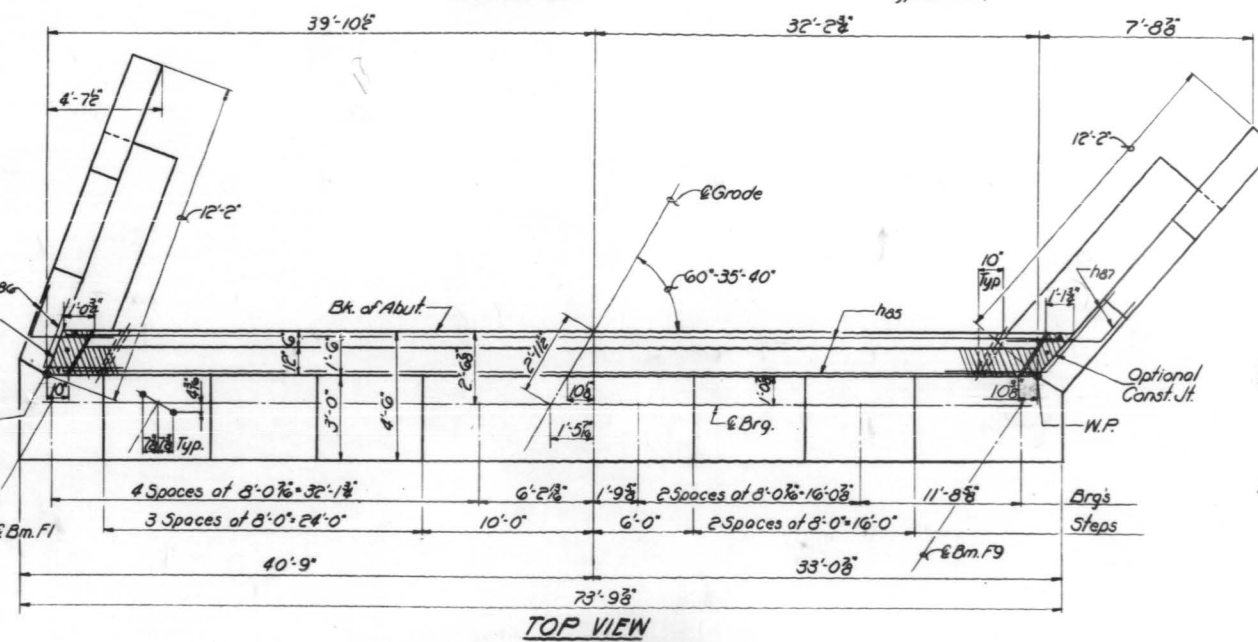
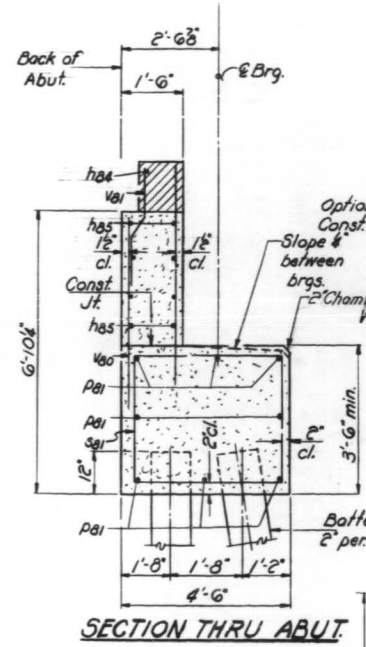
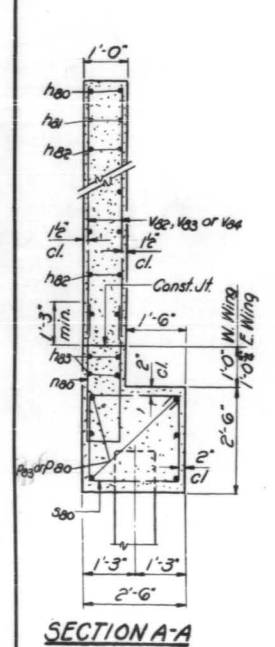
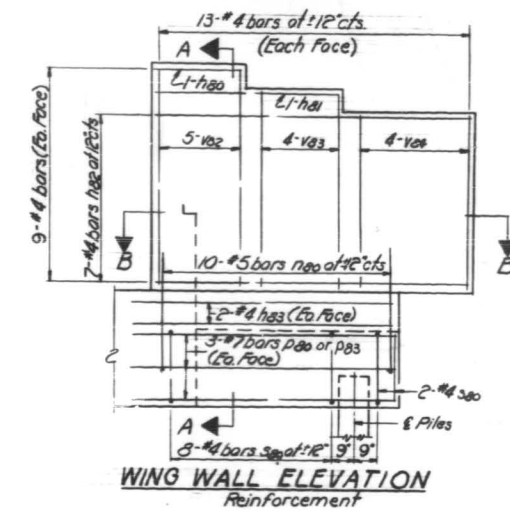
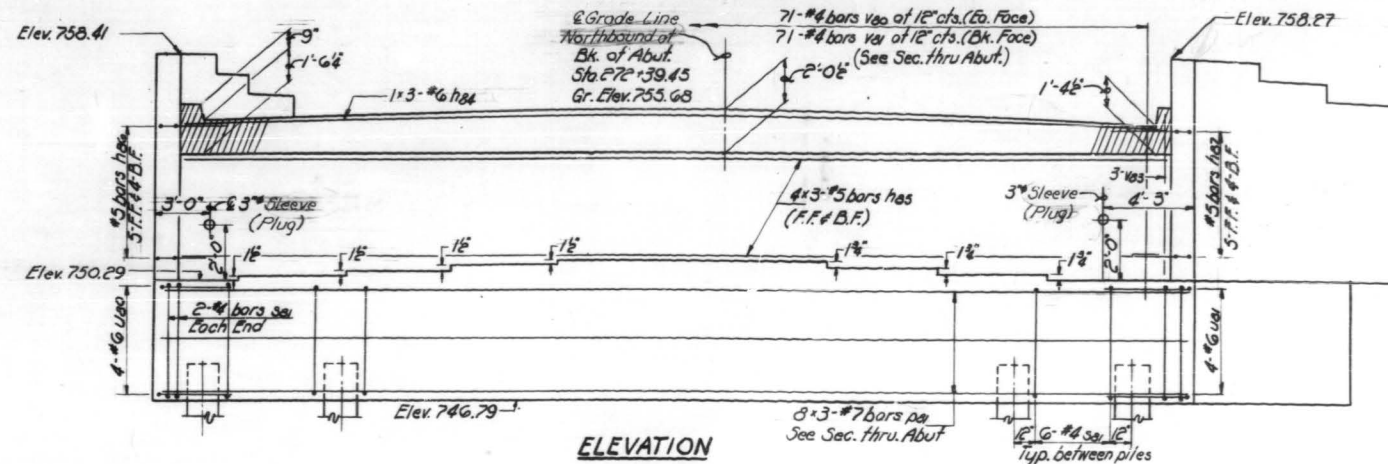
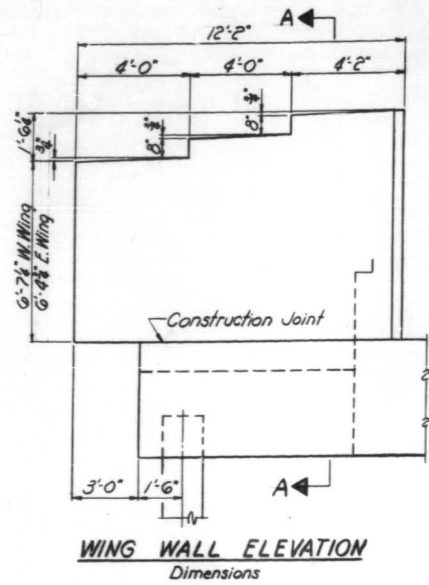

**PILE DATA**  
Type: Concrete  
Capacity: 35 Ton  
Est. Length: 65'-0"  
No. Required: 13

**SECTION B-B**  
**BILL OF MATERIAL**

Bar	No.	Size	Length	Shape
ha0	4	#4	3'-9"	—
ha1	4	#4	7'-9"	—
ha2	28	#4	11'-9"	—
has	8	#4	11'-0"	—
ha4	3	#6	24'-9"	—
has	24	#5	24'-9"	—
ha6	9	#5	4'-9"	—
ha7	9	#5	4'-9"	—
na0	20	#5	8'-9"	U
pa0	6	#7	10'-3"	—
pa1	24	#7	25'-9"	—
pa3	6	#7	8'-9"	—
sa0	20	#4	9'-5"	□
sa1	64	#4	15'-5"	□
ua0	4	#6	10'-9"	—
ua1	4	#6	12'-1"	—
va0	142	#4	5'-9"	—
va1	71	#4	4'-6"	—
va2	20	#4	7'-8"	—
va3	22	#4	7'-0"	—
va4	16	#4	6'-2"	—
Class X Concrete				Cu. Yds. 69.4
Reinforcement Bars				Lbs. 4760
Concrete Piles				Lin. Ft. 845

**NORTH ABUTMENT-UNIT F**  
S. B. I. ROUTE 53  
SEC. 531-2-VHB  
COOK COUNTY  
STATION 270+71.17

DESIGNED: *T. Dickerson*  
CHECKED: *Sally Chisler*  
DRAWN: *W. E. Dickerson*  
CHECKED: *B. C.*

EXAMINED: *W. Baumann*  
PASSED: *[Signature]*  
APPROVED: *[Signature]*

JUNE 16 1964



STATE OF ILLINOIS  
DEPARTMENT OF PUBLIC WORKS & BUILDINGS  
DIVISION OF HIGHWAYS

ROUTE NO.	SECTION	COUNTY	TOTAL SHEETS	SHEET NO.	SHEET NO. 46
53	531-2-VHB	COOK	67	51	60 SHEETS
FED. ROAD DIST. NO. 7		ILLINOIS	FED. AID PROJECT		

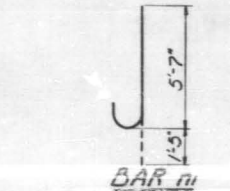
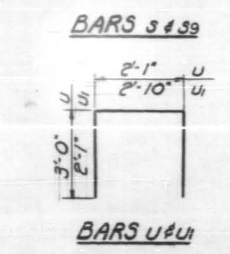
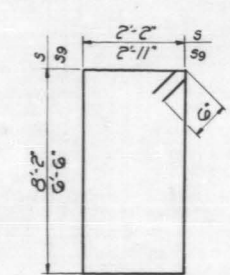
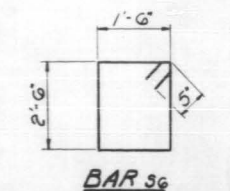
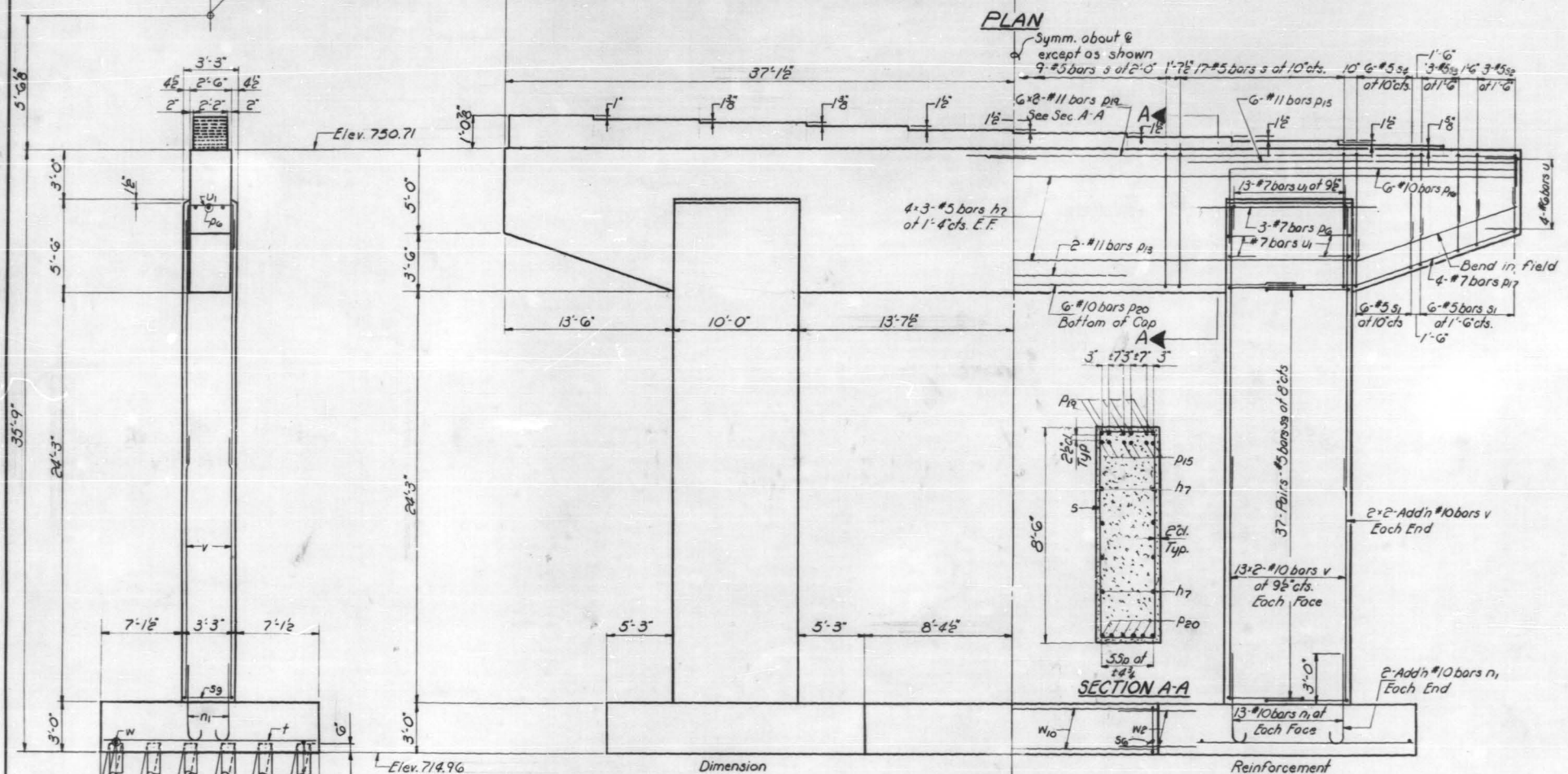
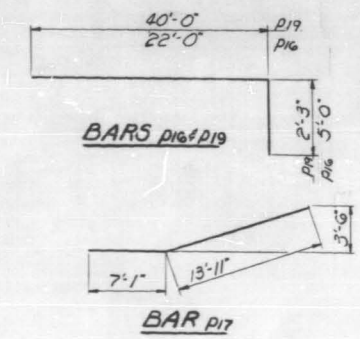
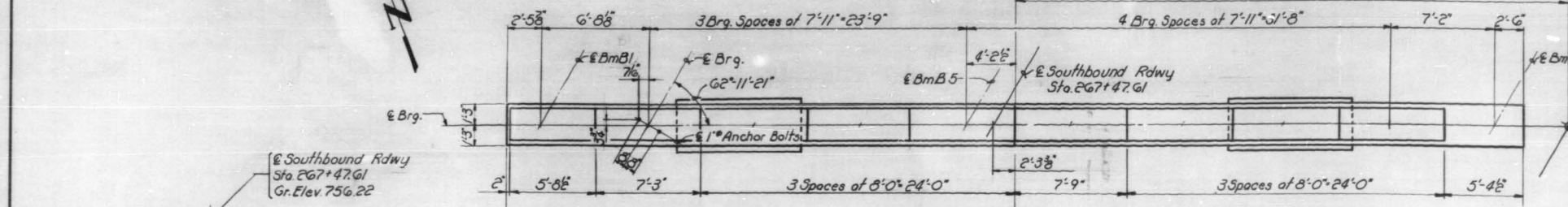

BILL OF MATERIAL

Bar	No	Size	Length	Shape
h7	24	#5	26'-3"	
n1	60	#10	7'-0"	C
p10	6	#7	14'-0"	
p13	2	#11	18'-0"	
p15	12	#11	29'-0"	
p16	12	#10	27'-0"	
p17	8	#7	21'-0"	
p19	12	#11	42'-3"	
p20	6	#10	38'-0"	
s	43	#5	21'-8"	□
s1	24	#5	7'-2"	□
s2	6	#5	9'-2"	□
s3	6	#5	12'-2"	□
s4	12	#5	15'-2"	□
s6	9	#8	8'-10"	□
s9	148	#5	19'-10"	□
t	66	#11	17'-0"	
u	8	#6	8'-1"	□
u1	34	#7	7'-0"	□
v	120	#10	16'-6"	
w	46	#9	20'-0"	
w2	8	#9	6'-0"	
w3	5	#9	16'-3"	
Class X Concrete		Cu. Yds	201.0	
Reinforcement Bars		Lbs	59,710	
Crested Piles		Lin. Ft.	2688	

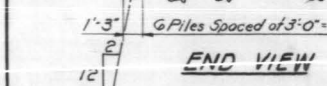

PILE DATA

Type: Crested  
Capacity: 20 Tons  
Est. Length: 32'-0"  
No. Req'd: 64

Note  
Battered piles shall be driven with the bottom ends away from the adjoining abutment.

DESIGNED	James P. Pence	EXAMINED	JUNE 16 1964
CHECKED	J. B. Nelson	PASSED	W. E. Dickerson
DRAWN	W. E. Dickerson	APPROVED	J. P.
CHECKED	J. P.		

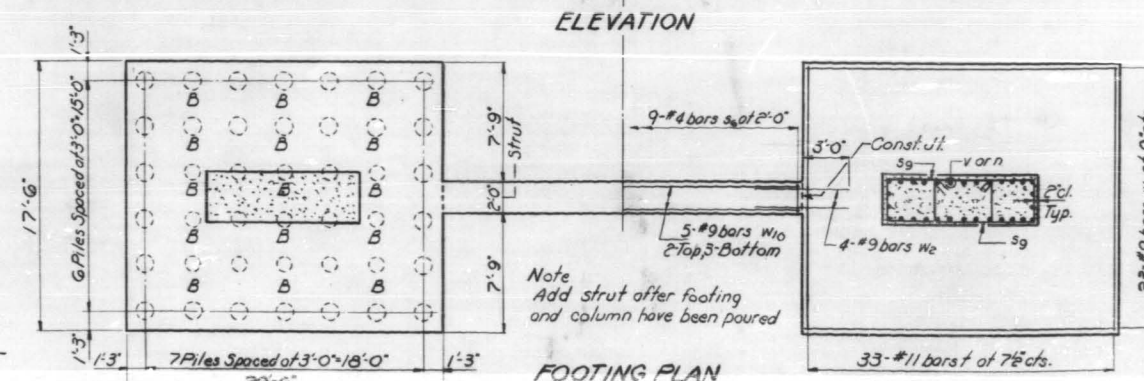

PIER 1 SOUTHBOUND  
S.B.I. ROUTE 53  
SEC. 531-2-VHB  
COOK COUNTY  
STATION 270+71.17





STATE OF ILLINOIS  
DEPARTMENT OF PUBLIC WORKS & BUILDINGS  
DIVISION OF HIGHWAYS

ROUTE NO.	SECTION	COUNTY	SHEET NO.	SHEET NO. OF SHEETS
53	531-2	COOK	67	52
SHEET NO. 47				
60 SHEETS				

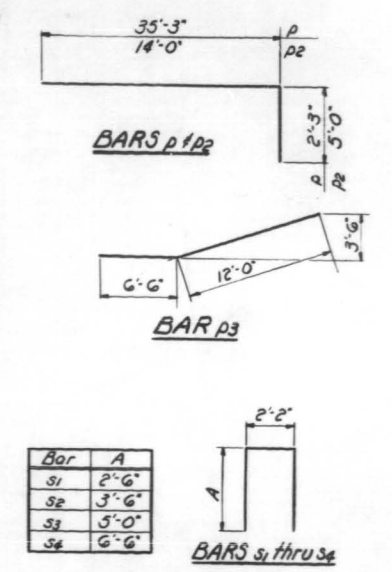
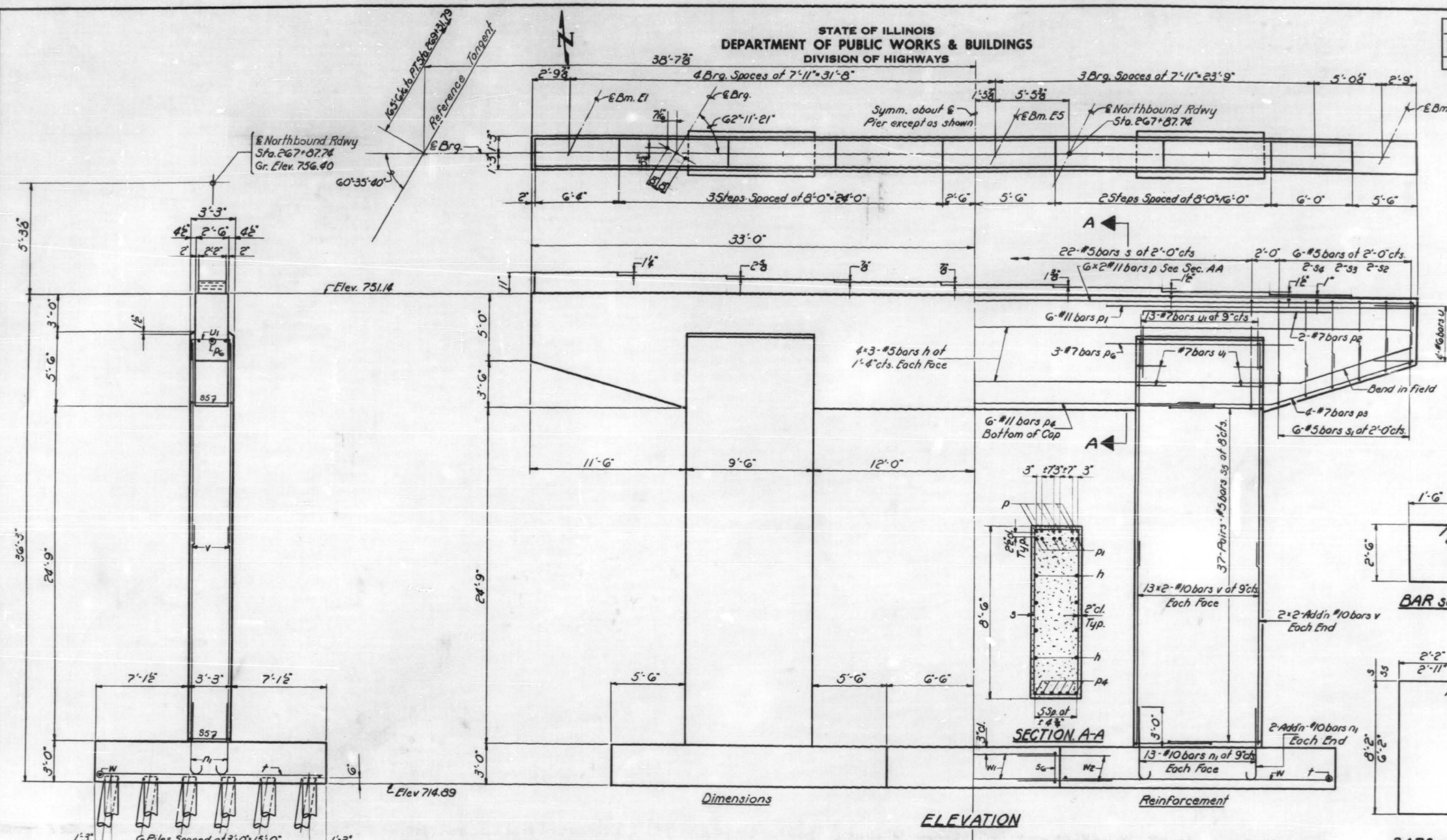

Bar	A
s1	2'-6"
s2	3'-6"
s3	5'-0"
s4	6'-6"

**BILL OF MATERIAL**

Bar	No	Size	Length	Shape
h	24	#5	24'-0"	—
n1	60	#10	7'-0"	—
p	12	#11	37'-6"	—
pl	12	#11	23'-0"	—
pl	4	#7	19'-0"	—
p3	8	#7	18'-6"	—
pl	6	#11	34'-0"	—
pl	6	#7	14'-0"	—
s	22	#5	21'-8"	—
s1	12	#5	7'-2"	—
s2	4	#5	9'-2"	—
s3	4	#5	12'-2"	—
s4	4	#5	15'-2"	—
s5	148	#5	19'-2"	—
s6	7	#4	8'-10"	—
t	66	#11	17'-0"	—
u	3	#6	8'-1"	—
u	34	#7	7'-0"	—
v	120	#10	16'-6"	—
w	46	#9	20'-0"	—
w1	4	#9	12'-6"	—
w2	8	#9	6'-0"	—
Class X Concrete				Cu. Yds. 191.4
Reinforcement Bars				Lbs. 30240
Cresosofed Piles				Lin. Ft. 2688

**END VIEW**

**PILE DATA**  
Type-Cresosofed  
Capacity-20 Tons  
Est. Length-32'-0"  
No. Req'd-34

**NOTE:**  
Battered piles shall be driven with the bottom ends away from the adjoining abutment. Add strut after footing and columns have been poured.

DESIGNED <i>James M. Ponce</i>	EXAMINED <i>W.E. Dickerson</i>
CHECKED <i>J.P.</i>	PASSED <i>W.E. Dickerson</i>
DRAWN <i>W.E. Dickerson</i>	APPROVED <i>W.E. Dickerson</i>
CHECKED <i>J.P.</i>	

JUNE 16 1964  
CHIEF ENGINEER

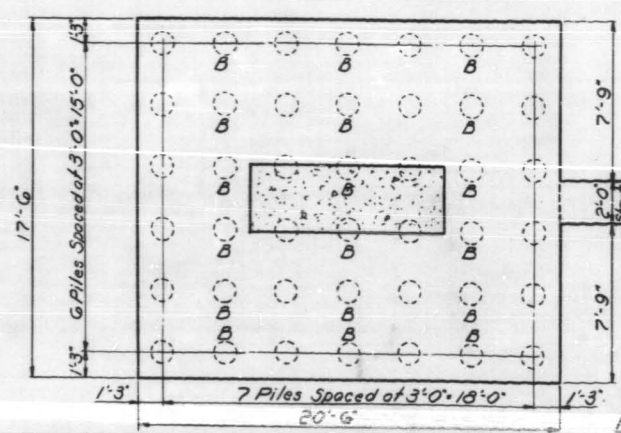

**ELEVATION**

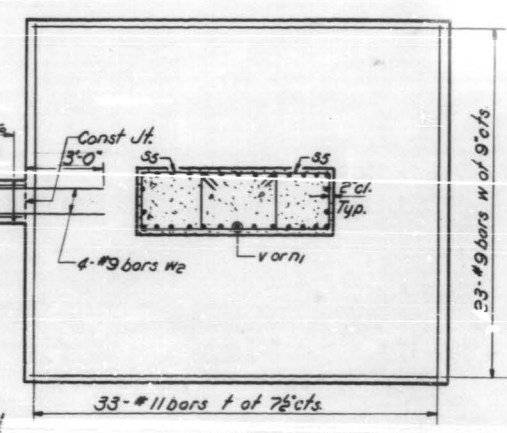

**BARS s1 & s5**

**BARS u1 & u2**

**BAR n1**

**PIER 1 NORTHBOUND**  
S.B.I. ROUTE 53  
SEC. 531-2-VHB  
COOK COUNTY  
STATION 270+71.17





STATE OF ILLINOIS  
DEPARTMENT OF PUBLIC WORKS & BUILDINGS  
DIVISION OF HIGHWAYS

ROUTE NO.	SECTION	COUNTY	TOTAL SHEETS	SHEET NO.
S. I. 53	531-2	COOK	67	53
P. A. 61	VHB			

SHEET NO. 48  
60 SHEETS

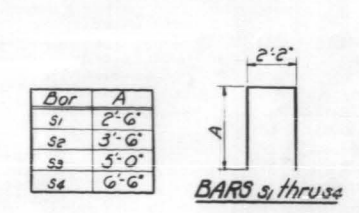
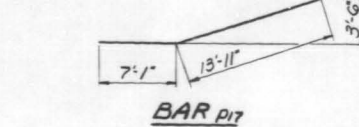
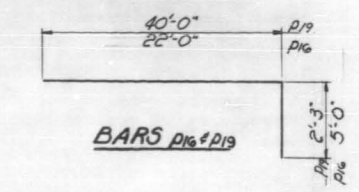
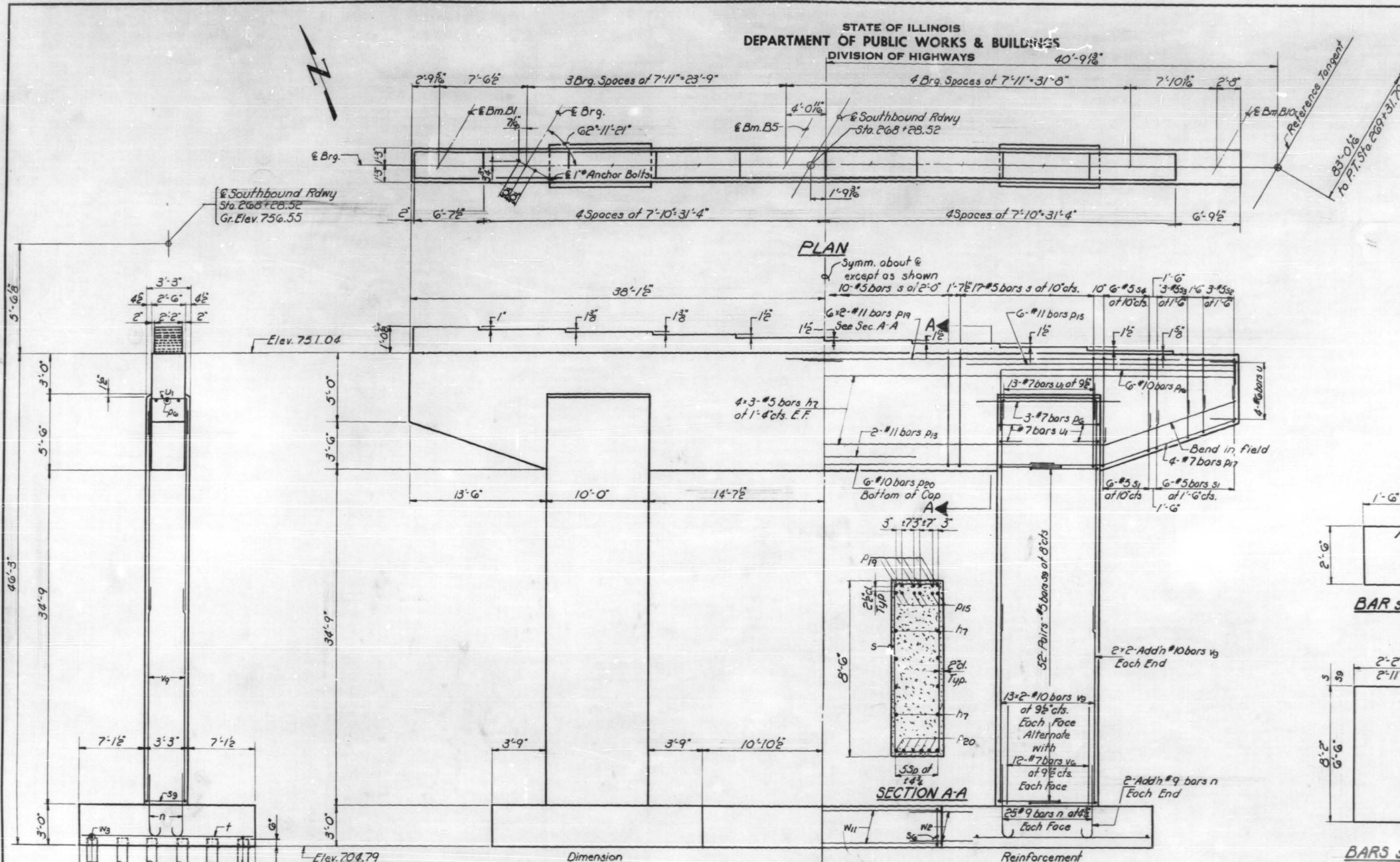

BILL OF MATERIAL

Bar	No	Size	Length	Shape
h7	24	#5	26'-3"	—
n	108	#9	6'-9"	—
h6	6	#7	14'-0"	—
p19	2	#11	18'-0"	—
p15	12	#11	29'-0"	—
p16	12	#10	27'-0"	—
p17	8	#7	21'-0"	—
p19	12	#11	42'-3"	—
p20	6	#10	38'-0"	—
s	44	#5	21'-8"	□
s1	24	#5	7'-2"	□
s2	6	#5	9'-2"	□
s3	6	#5	12'-2"	□
s4	12	#5	15'-2"	□
s6	11	#4	8'-10"	□
s9	208	#5	19'-10"	□
t	56	#11	17'-0"	—
u	8	#6	8'-1"	—
u1	34	#7	7'-0"	—
v6	48	#7	16'-0"	—
v9	120	#10	21'-0"	—
w6	8	#9	6'-0"	—
w3	46	#9	17'-0"	—
w11	5	#9	21'-3"	—
Class X Concrete			Cu. Yds. 217.6	
Reinforcement Bars			Lbs. 37,860	
Crested Piles			Lin. Ft. 1872	

PILE DATA

Type: Crested  
Capacity: 20 Tons  
Est. Length: 26'-0"  
No. Req'd: 72

DESIGNED	James W. Ponce	EXAMINED	W.E. Dickerson
CHECKED	J. B. Nelson	PASSED	W.E. Dickerson
DRAWN	W.E. Dickerson	APPROVED	J.P.
CHECKED	J.P.		

JUNE 16 1968

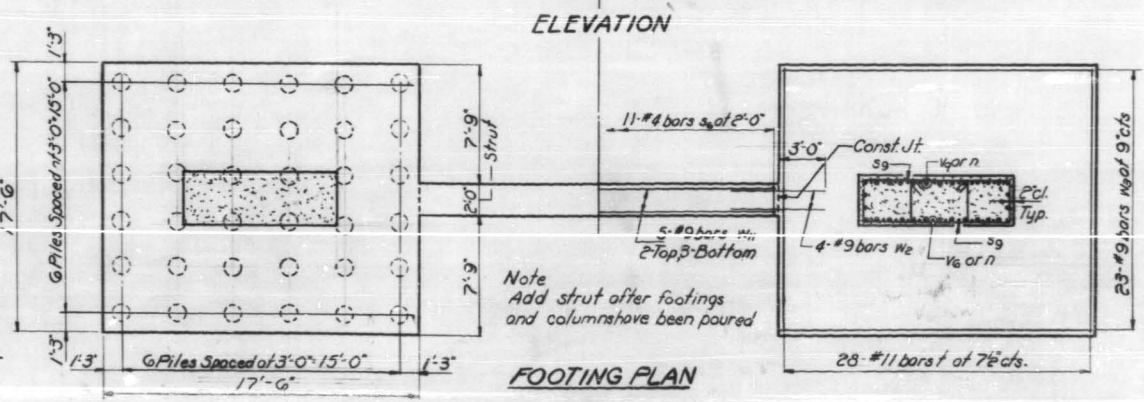

PIER 2 SOUTHBOUND  
S.B.I. ROUTE 53  
SEC. 531-2-VHB  
COOK COUNTY  
STATION 270+7.17





STATE OF ILLINOIS  
DEPARTMENT OF PUBLIC WORKS & BUILDINGS  
DIVISION OF HIGHWAYS

ROUTE NO.	SECTION	COUNTY	TOTAL SHEETS	SHEET NO.	SHEET NO.
S. R. 53	531-2-VHB	COOK	67	54	60 SHEETS
P.A. 41					
FED. ROAD DIST. NO. 7	ILLINOIS	FED. AID PROJECT			

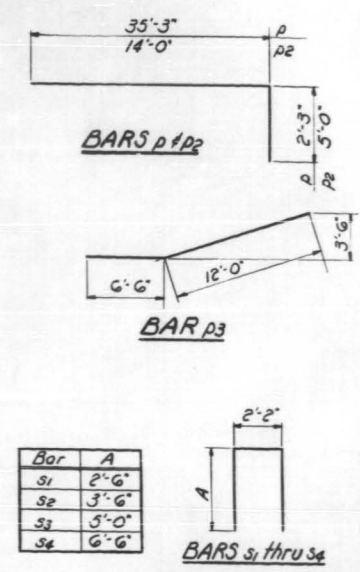
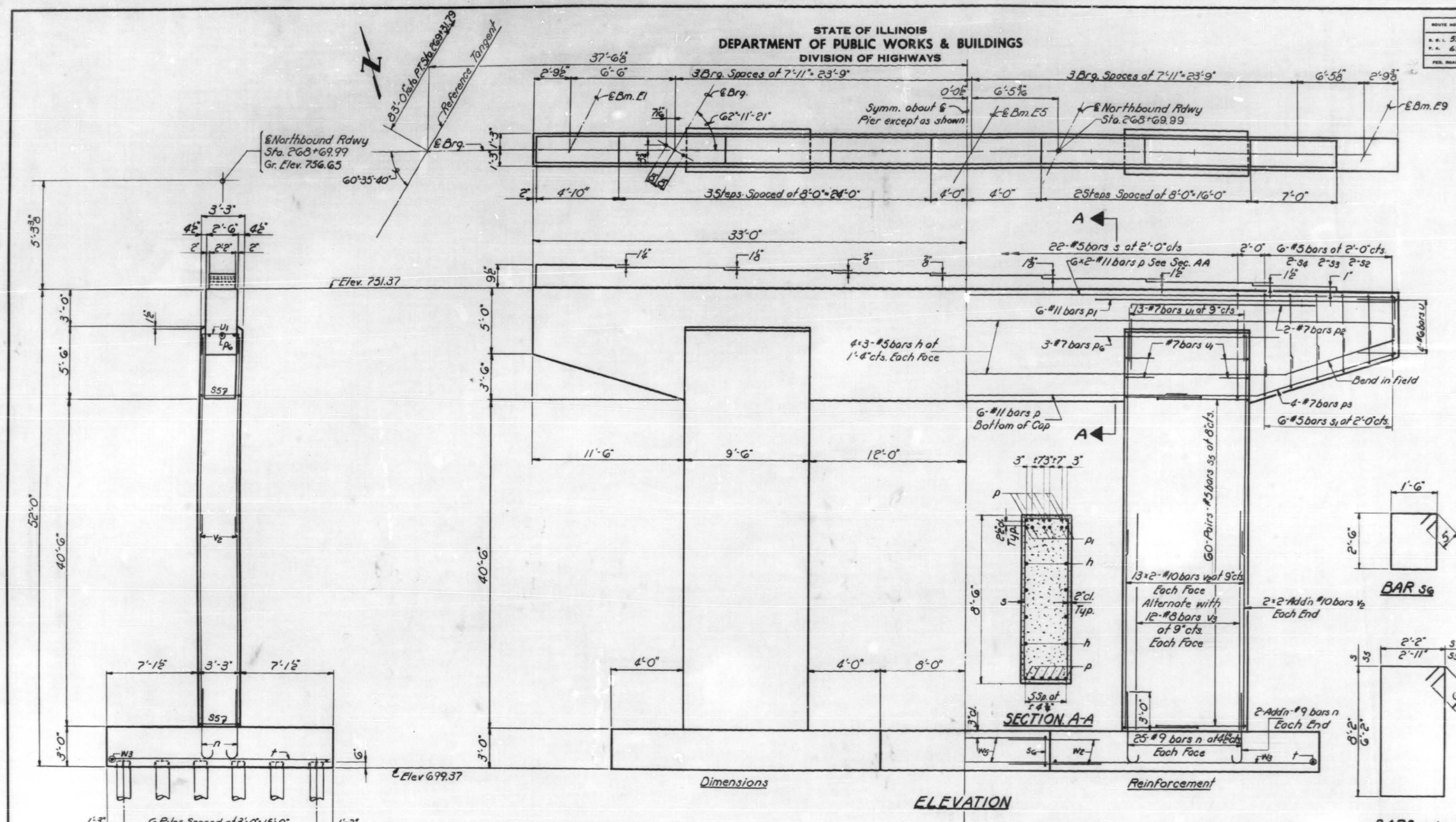

**BILL OF MATERIAL**

Bar	No	Size	Length	Shape
h	24	#5	24'-0"	—
n	108	#9	17'-0"	C
p	12	#11	37'-6"	—
p1	12	#11	23'-0"	—
p2	6	#7	19'-0"	—
p3	8	#7	18'-6"	—
p4	6	#11	34'-0"	—
p6	6	#7	14'-0"	—
s	22	#5	21'-8"	□
s1	12	#5	7'-2"	□
s2	4	#5	9'-2"	□
s3	4	#5	12'-2"	□
s4	4	#5	15'-2"	□
s5	240	#5	19'-2"	□
s6	9	#4	8'-10"	□
t	56	#11	17'-0"	—
u	8	#6	8'-1"	□
u1	34	#7	7'-0"	□
v2	120	#10	24'-0"	—
v3	48	#8	23'-0"	—
w2	8	#9	6'-0"	—
w3	46	#9	17'-0"	—
w5	4	#9	15'-6"	—
Mass Concrete	Cu. Yds.	216.4		
Reinforcement Bars	Lbs.	38,250		
Crescoted Piles	Lin. Ft.	1584		
Test Pile (Timber)	Each	1		

**PILE DATA**  
Type-Crescoted  
Capacity-20 Tons  
Est. Length 22'-0"  
No. Req'd-72

Add strut after footing and columns have been poured.

DESIGNED James M. Pance	EXAMINED H. G. Baumann
CHECKED J. N. P.	PASSED [Signature]
DRAWN W. E. Dickerson	APPROVED [Signature]
CHECKED J. N. P.	

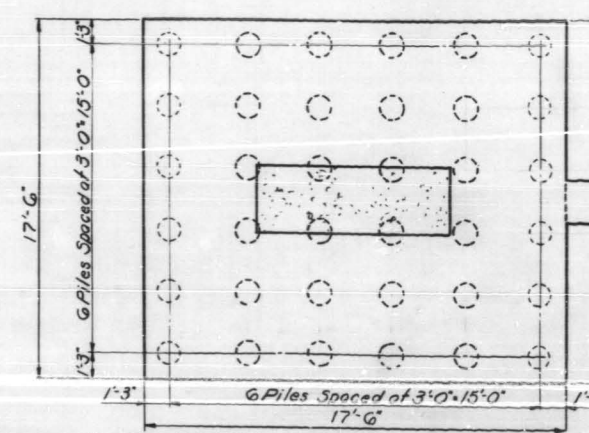

**PIER 2 NORTHBOUND**  
S.B.I. ROUTE 53  
SEC. 531-2-VHB  
COOK COUNTY  
STATION 270+71.17









STATE OF ILLINOIS  
DEPARTMENT OF PUBLIC WORKS & BUILDINGS  
DIVISION OF HIGHWAYS

ROUTE NO.	SECTION	COUNTY	TOTAL SHEETS	SHEET NO.	SHEET NO. 51
53	531-2	COOK	67	56	60 SHEETS
P.A. 61	-VHB				
FED. ROAD DIST. NO. 7		ILLINOIS	FED. AID PROJECT		

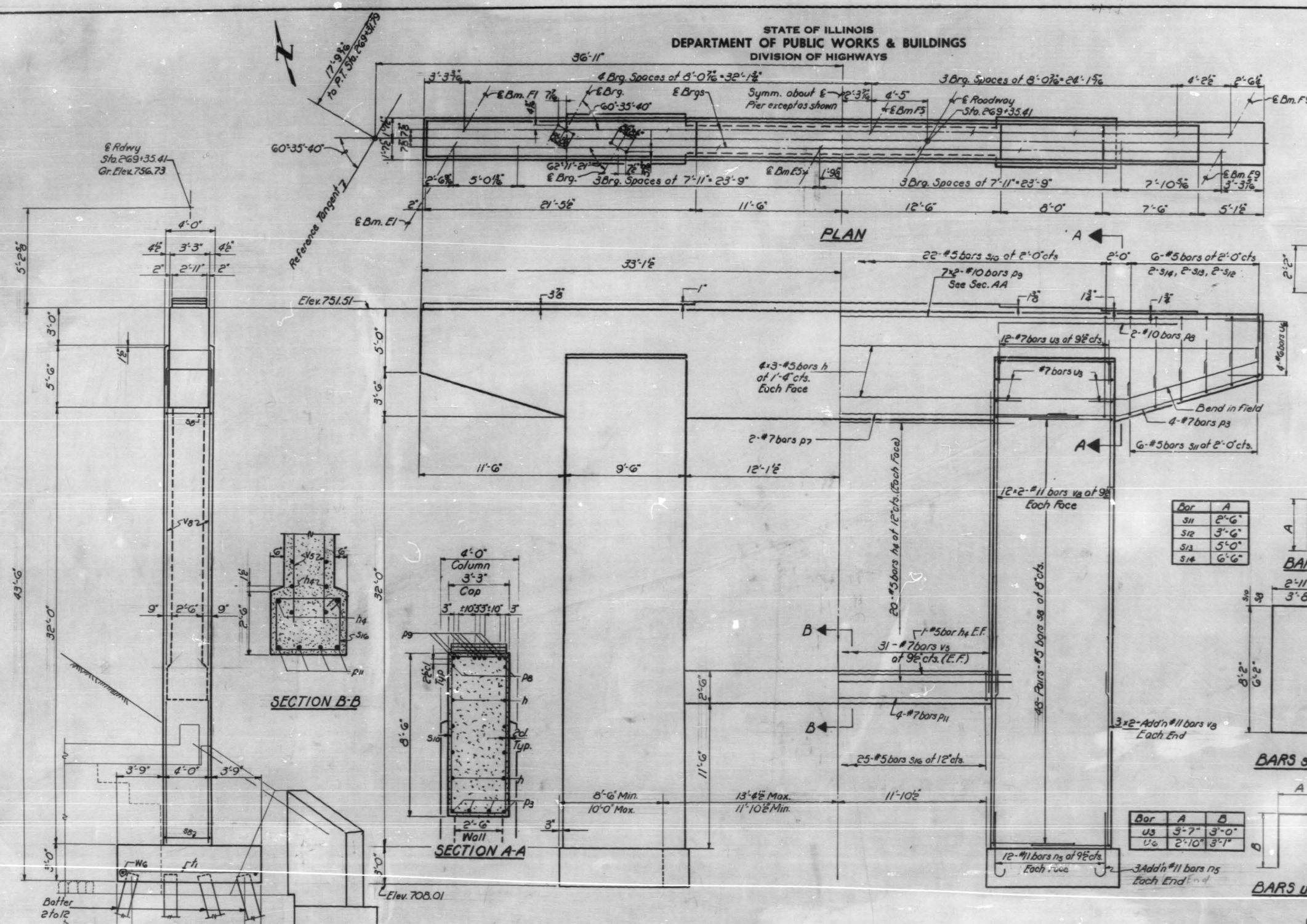

Bars	No	Size	Length	Shape
h4	40	#5	28'-0"	
n5	60	#11	7'-6"	C
p3	8	#7	18'-6"	
p7	2	#7	34'-0"	
p8	4	#10	19'-0"	
p9	14	#10	37'-6"	
p11	4	#7	26'-0"	
s8	192	#5	20'-8"	
s10	22	#5	23'-2"	
s11	12	#5	7'-11"	
s12	4	#5	9'-11"	
s13	4	#5	12'-11"	
s14	4	#5	15'-11"	
s16	25	#5	12'-0"	
h	40	#8	11'-0"	
u3	32	#7	9'-7"	
u6	8	#6	9'-0"	
v5	66	#7	21'-6"	
v8	120	#11	21'-0"	
v16	30	#6	9'-6"	

Expansion Bolts 3/4"	Each	24
Temporary Shoring	Sq. Ft.	1953
Class X Concrete	Cu. Yds.	251.9
Reinforcement Bars	Lbs.	31560
Precast Concrete Piles 14"	Lin. Ft.	960
Concrete Removal	Cu. Yds.	19

DESIGNED *J. N. P.*  
CHECKED *James H. Pence*  
DRAWN *M. A. Dickerson*  
CHECKED *J. N. P.*

EXAMINED *H. B. Baumann*  
PASSED *Shurtz*  
APPROVED *J. N. P.*

JUNE 16 1964

FILE DATA  
Type: Precast Concrete  
Capacity: 45 Tons  
Est. Length: 40'-0"  
No. Reqd: 24

\* Includes quantities of reinforcement and Class X Concrete required for culvert. See next sheet for bar list.

PIER 3 NORTHBOUND  
S.B.I. ROUTE 53  
SEC. 531-2-VHB  
COOK COUNTY  
STATION 270+71.17





Remove existing wing wall and portion of footing approx as shown to clear new structure as required by the engineer.

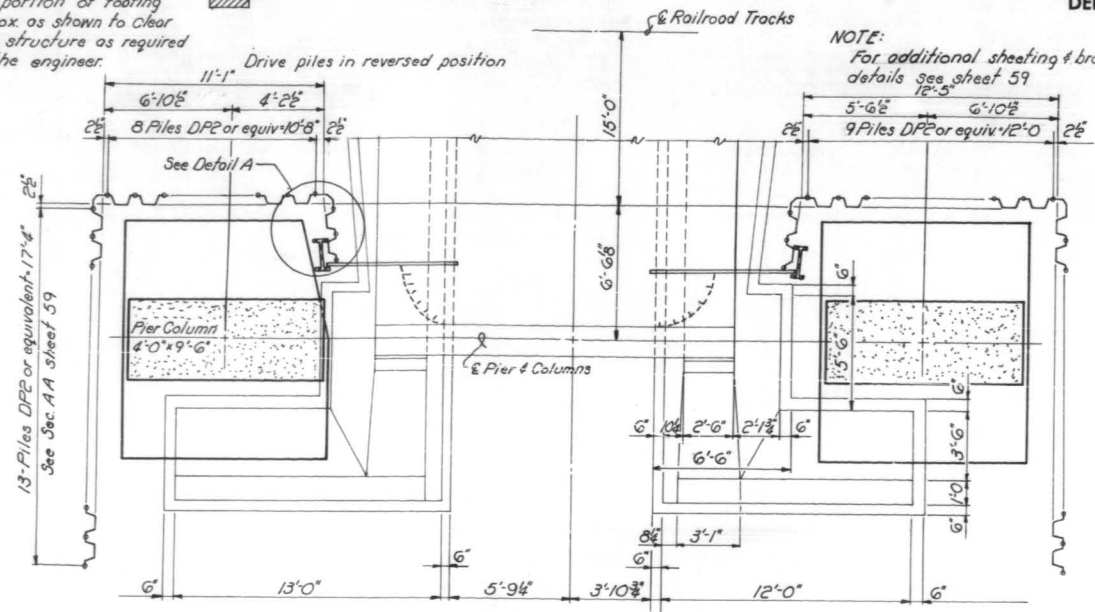

PLAN VIEW-EXISTING FOOTING DIMENSIONS & SHEETING

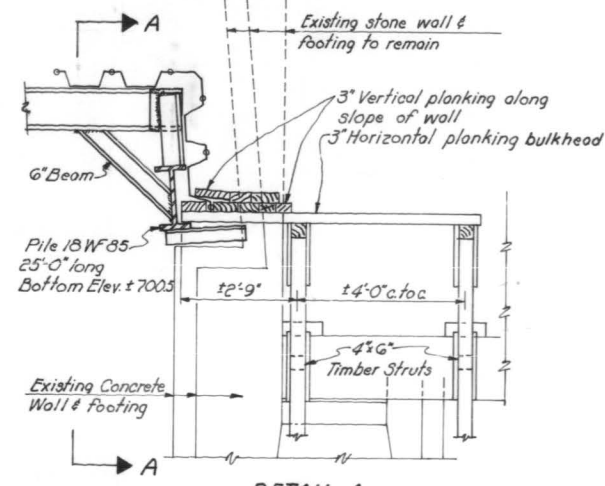

DETAIL A

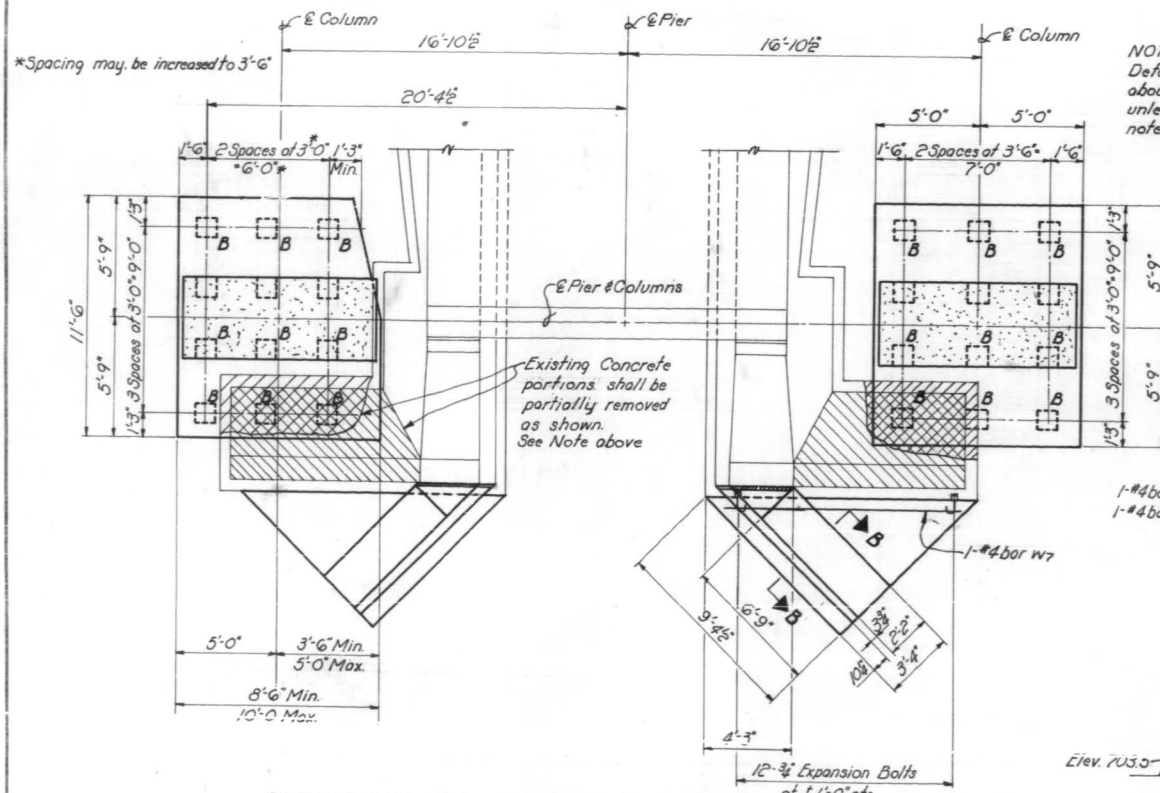

PLAN VIEW-PIER FOOTING DIMENSION & PILES

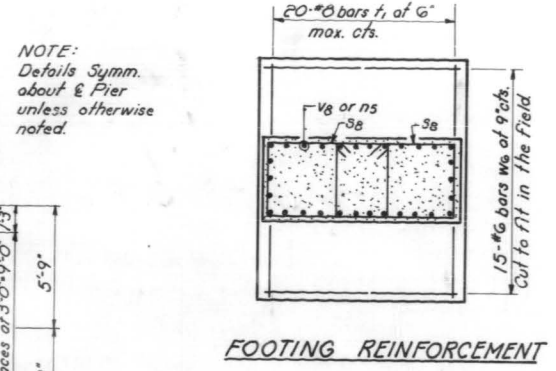

FOOTING REINFORCEMENT

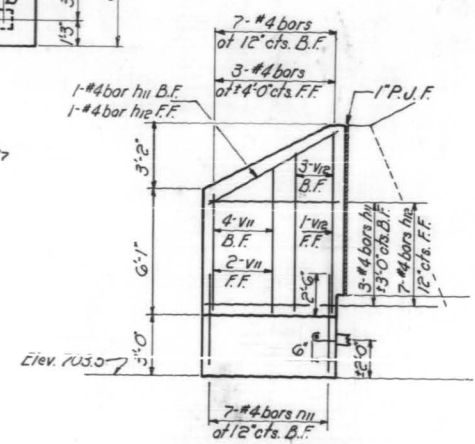

WING WALL DIMENSIONS & REINFORCEMENT

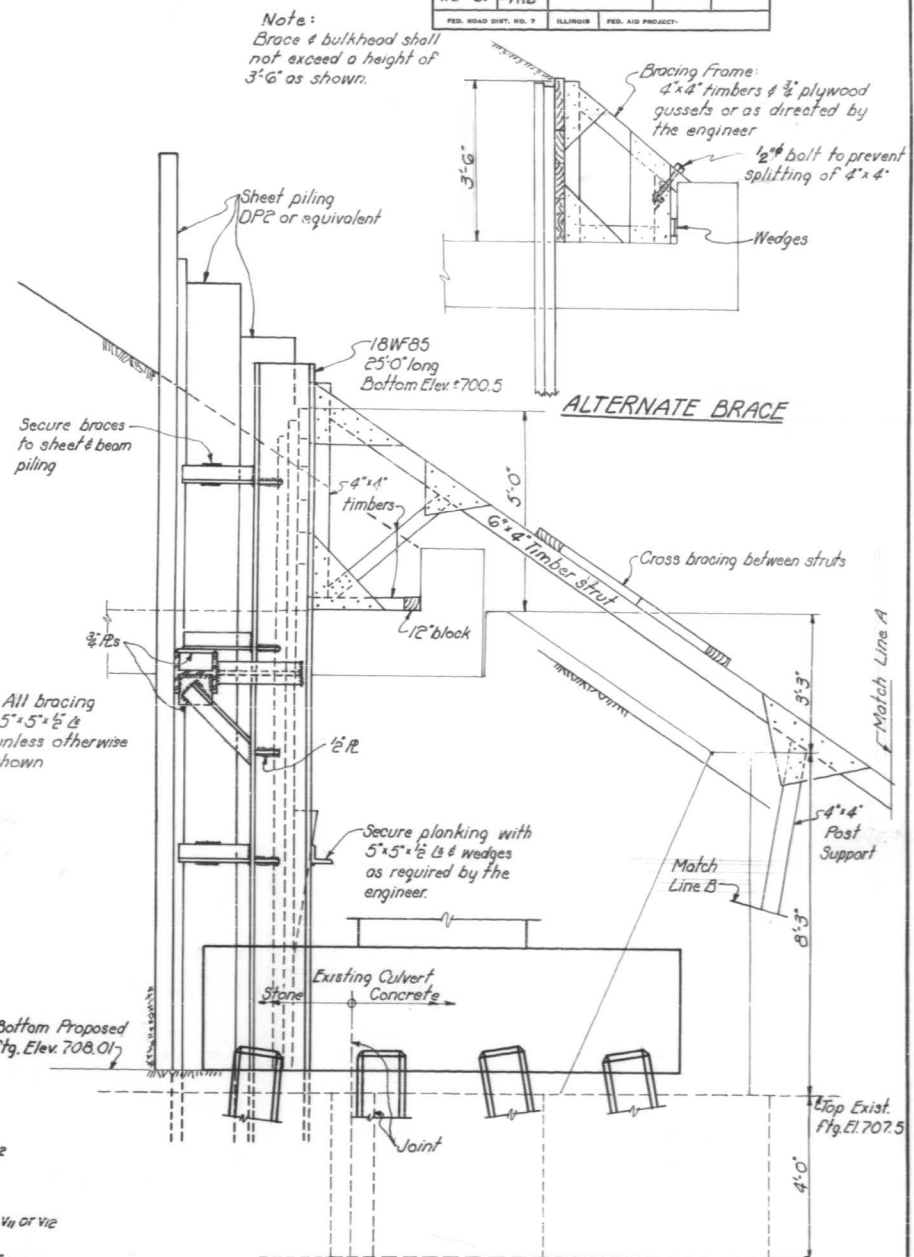

SECTION A-A

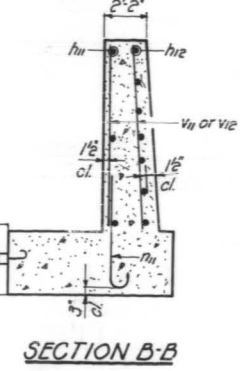

SECTION B-B

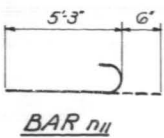

BAR #11

WING WALL BAR LIST

Bar	No.	Size	Length	Shape
v1	12	#4	5'-0"	
v2	8	#4	8'-3"	
v11	14	#4	5'-9"	C
v12	8	#4	6'-3"	
v12	16	#4	8'-0"	
w7	2	#4	12'-0"	

211 Cu. Yds. Class X Concrete and 280 lbs Reinforcement bars used in Culvert Wingwalls extensions are included in Bill of Material sheet 51

**PIER 3 NORTHBOUND**  
S. B. I. ROUTE 53  
SEC. 531-2-VHB  
COOK COUNTY  
STATION 270+71.7

DESIGNED J. B. Nelson  
CHECKED James M. Ponce  
DRAWN W. A. E. Dickerson  
CHECKED J. N. P.

EXAMINED J. E. P. [Signature]  
PASSED [Signature]  
APPROVED [Signature]

NOTE: Expansion bolts shall consist of self-drilling expansion shell and hooked bolts.



STATE OF ILLINOIS  
DEPARTMENT OF PUBLIC WORKS & BUILDINGS  
DIVISION OF HIGHWAYS

PROJECT NO. 53-2-VHB  
COUNTY COOK  
SHEET NO. 53  
SHEETS 60

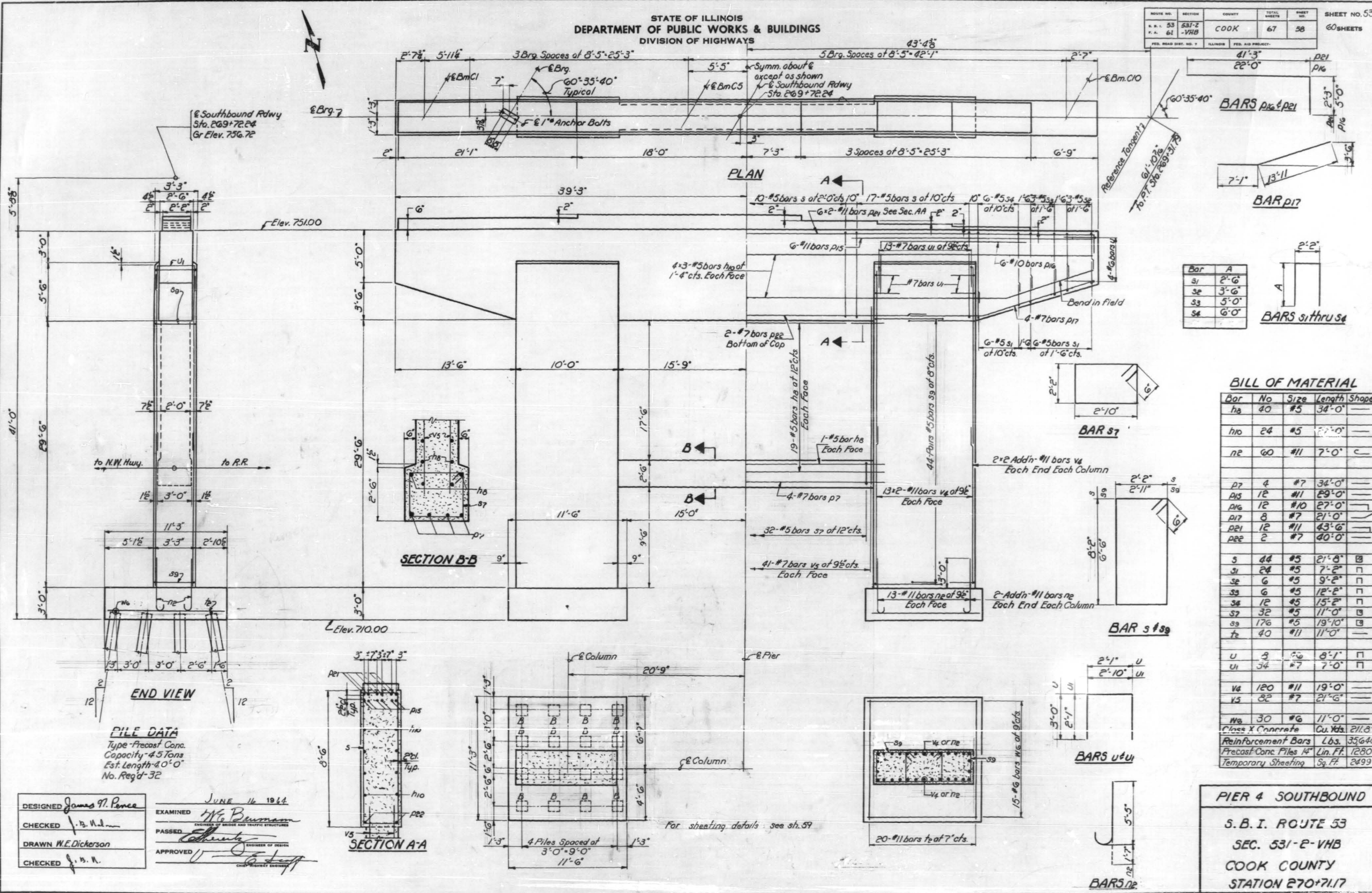

Bar	A
s1	2'-6"
s2	3'-6"
s3	5'-0"
s4	6'-0"

**BILL OF MATERIAL**

Bar	No	Size	Length	Shape
ha	40	#5	34'-0"	—
ho	24	#5	27'-0"	—
ne	60	#11	7'-0"	C
p7	4	#7	34'-0"	—
ps	12	#11	29'-0"	—
ps6	12	#10	27'-0"	—
p17	8	#7	21'-0"	—
pe1	12	#11	43'-6"	—
pe2	2	#7	40'-0"	—
s	44	#5	21'-8"	□
s1	24	#5	7'-2"	□
s2	6	#5	9'-2"	□
s3	6	#5	12'-2"	□
s4	12	#5	15'-2"	□
s7	32	#5	11'-0"	□
s9	176	#5	19'-10"	□
te	40	#11	11'-0"	—
u	3	#5	8'-1"	□
u1	34	#7	7'-0"	□
v4	120	#11	19'-0"	—
v5	32	#7	21'-6"	—
w6	30	#6	11'-0"	—
Class X Concrete Cu. Yds. 211.8				
Reinforcement Bars Lbs. 35640				
Precast Conc. Piles 14" Lin. Ft. 1280				
Temporary Sheeting Sq. Ft. 2499				





STATE OF ILLINOIS  
DEPARTMENT OF PUBLIC WORKS & BUILDINGS  
DIVISION OF HIGHWAYS

ROUTE NO.	SECTION	COUNTY	TOTAL SHEETS	SHEET NO.
53	531-2-VHB	COOK	67	99
SHEET NO. 54				
60 SHEETS				

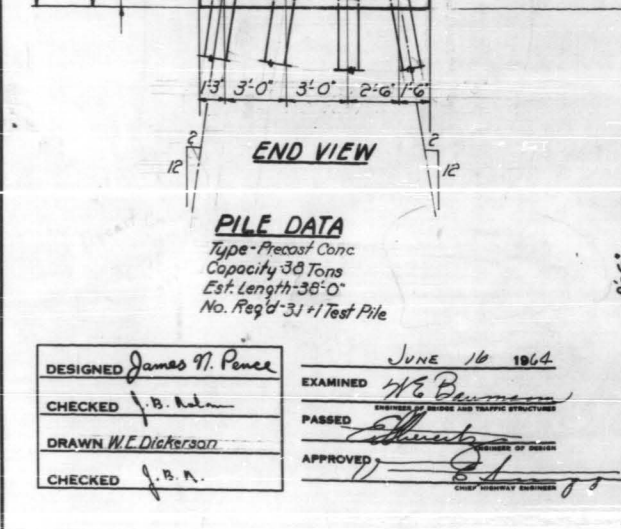
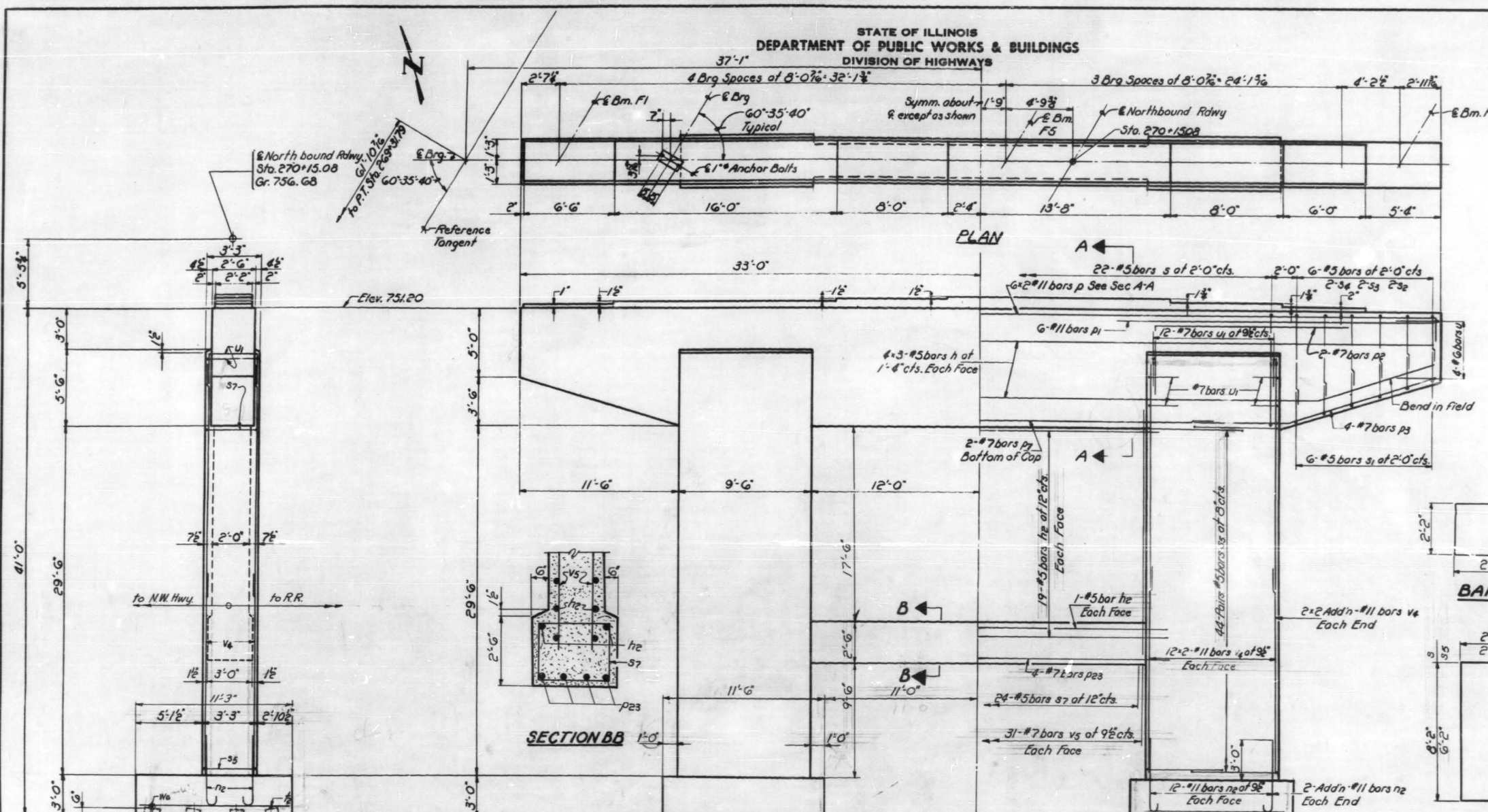

**PILE DATA**  
Type - Precast Conc  
Capacity 38 Tons  
Est. Length 38'-0"  
No. Req'd 31 + 1 Test Pile

DESIGNED James T. Ponce  
CHECKED B. A. ...  
DRAWN W.E. Dickerson  
CHECKED J.B.A.

EXAMINED W.E. Beermann  
PASSED ...  
APPROVED ...

JUNE 16 1964

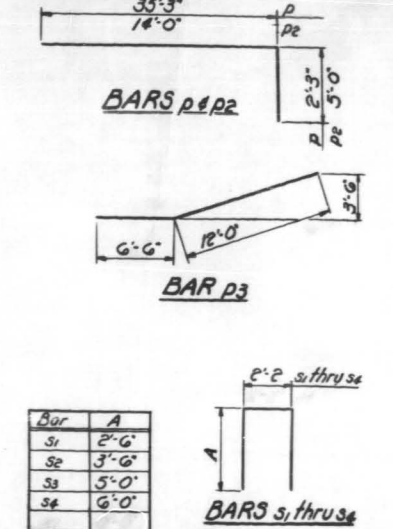
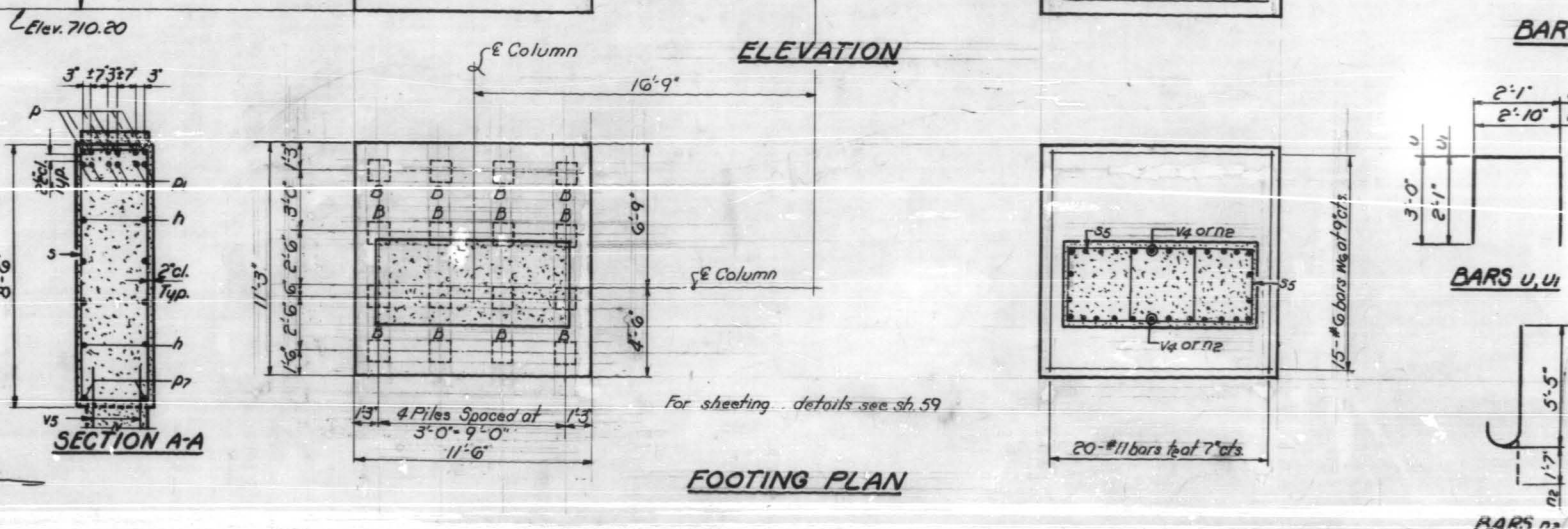

**BILL OF MATERIAL**

Bar	No	Size	Length	Shape
h	24	#5	24'-0"	
h2	40	#5	2'-0"	
n2	36	#11	7'-0"	
p	12	#11	37'-6"	
p1	12	#11	23'-0"	
p2	4	#7	18'-0"	
p3	8	#7	18'-0"	
p7	2	#7	34'-0"	
p23	4	#7	26'-0"	
s	22	#5	21'-8"	
s1	12	#5	7'-2"	
s2	4	#5	9'-2"	
s3	4	#5	12'-2"	
s4	4	#5	15'-2"	
s5	176	#5	19'-2"	
s7	24	#5	11'-0"	
u	8	#6	8'-1"	
u1	32	#7	7'-0"	
v4	112	#11	19'-0"	
v5	62	#7	21'-6"	
w6	30	#6	11'-0"	
z6	40	#11	11'-0"	
Temporary Sheeting Sq. Ft. 2499				
Class X Concrete Cu. Yds. 185.7				
Reinforcement Bars Lbs. 30390				
Precast Conc. Piles # Lin. Ft. 1178				
Test Pile (Prec. Conc.) Each 1				

**PIER 4 NORTHBOUND**  
S.B.I. ROUTE 53  
SEC. 531-2-VHB  
COOK COUNTY  
STATION 270+71.17





STATE OF ILLINOIS  
DEPARTMENT OF PUBLIC WORKS & BUILDINGS  
DIVISION OF HIGHWAYS

ROUTE NO.	SECTION	COUNTY	TOTAL SHEETS	SHEET NO.
531-2	VHB	COOK	67	60
SHEET NO. 55				
60 SHEETS				

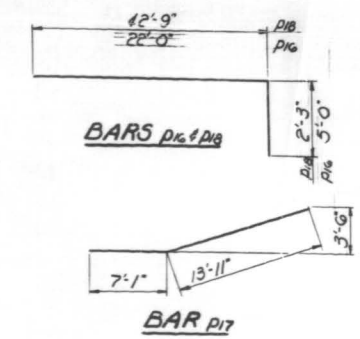
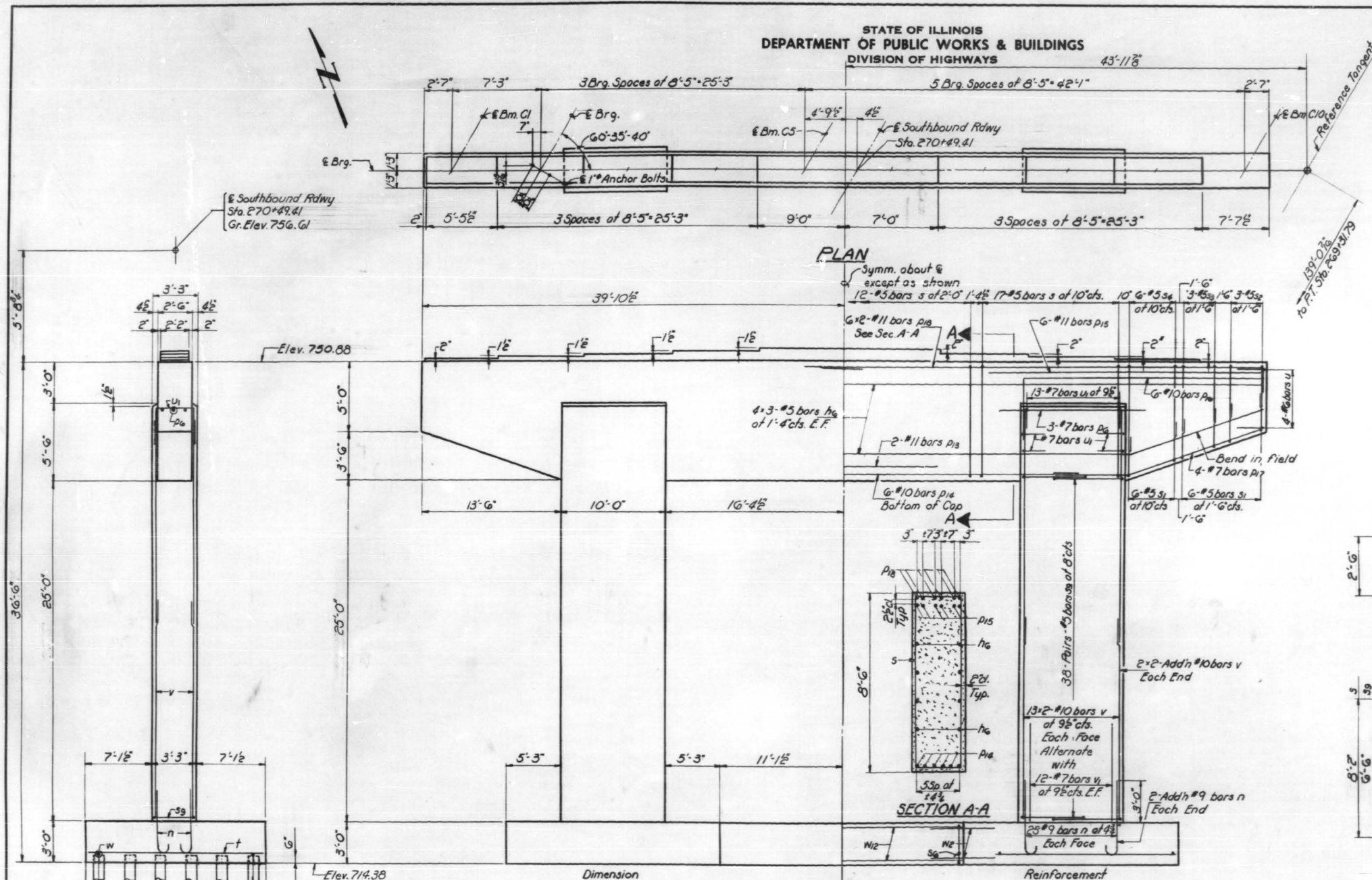

Bar	A
s1	2'-6"
s2	3'-6"
s3	5'-0"
s4	6'-6"



**BILL OF MATERIAL**

Bar	No	Size	Length	Shape
h <sub>a</sub>	24	#5	27'-9"	—
n	108	#9	6'-9"	C
p <sub>6</sub>	6	#7	14'-0"	—
p <sub>13</sub>	2	#11	18'-0"	—
p <sub>14</sub>	6	#10	43'-0"	—
p <sub>15</sub>	12	#11	29'-0"	—
p <sub>16</sub>	12	#10	27'-0"	—
p <sub>17</sub>	8	#7	21'-0"	—
p <sub>18</sub>	12	#11	45'-0"	—
s	46	#5	21'-8"	□
s <sub>1</sub>	24	#5	7'-2"	□
s <sub>2</sub>	6	#5	9'-2"	□
s <sub>3</sub>	6	#5	12'-2"	□
s <sub>4</sub>	12	#5	15'-2"	□
s <sub>6</sub>	11	#8	8'-10"	□
s <sub>9</sub>	152	#5	19'-10"	□
t	66	#11	17'-0"	—
u	8	#6	8'-1"	□
u <sub>1</sub>	34	#7	7'-0"	□
v	120	#10	16'-6"	—
v <sub>1</sub>	48	#7	7'-6"	—
w	46	#9	20'-0"	—
w <sub>2</sub>	8	#9	6'-0"	—
w <sub>3</sub>	5	#9	21'-9"	—
Class X Concrete				Cu. Yds 207.5
Reinforcement Bars				Lbs. 35,310
Creosoted Piles				Lin. Ft. 3024
Test Piles (Timber)				Each 1

**PILE DATA**

Type: Creosoted  
Capacity: 20 Tons  
Est. Length: 36'-0"  
No. Req'd: 84

DESIGNED	J. M. Power
CHECKED	J. B. Nelson
DRAWN	W. E. Dickerson
CHECKED	J. N. P.

EXAMINED  
PASSED  
APPROVED

JUNE 16 1964

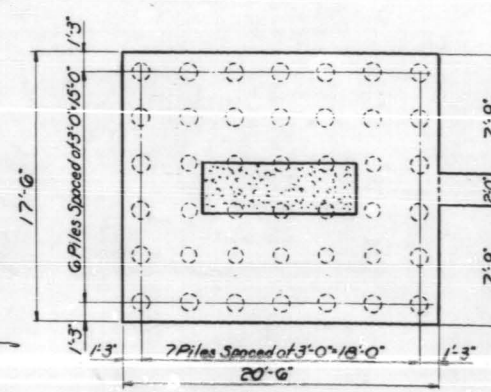

**ELEVATION**

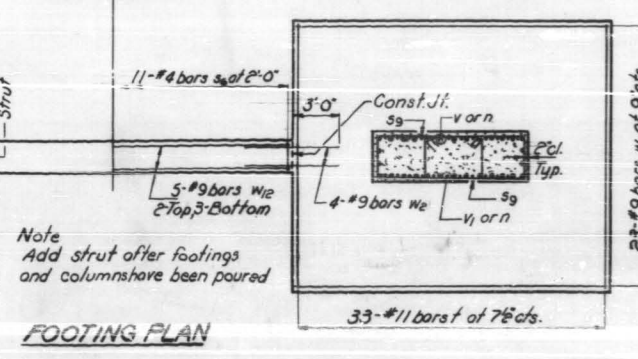

**FOOTING PLAN**

Note  
Add strut after footings  
and columns have been poured

**PIER 5 SOUTHBOUND**  
S.B.I. ROUTE 53  
SEC. 531-2-VHB  
COOK COUNTY  
STATION 270+71.7





STATE OF ILLINOIS  
DEPARTMENT OF PUBLIC WORKS & BUILDINGS  
DIVISION OF HIGHWAYS

ROUTE NO.	SECTION	COUNTY	TOTAL SHEETS	SHEET NO.	SHEET NO. 56
S. I. 53	531-2	COOK	67	61	60 SHEETS
P.A. 61	-VHB				
FED. ROAD DIST. NO. 7	ILLINOIS	FED. AID PROJECT:			

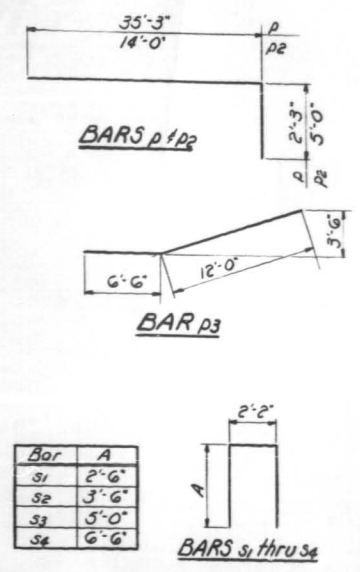
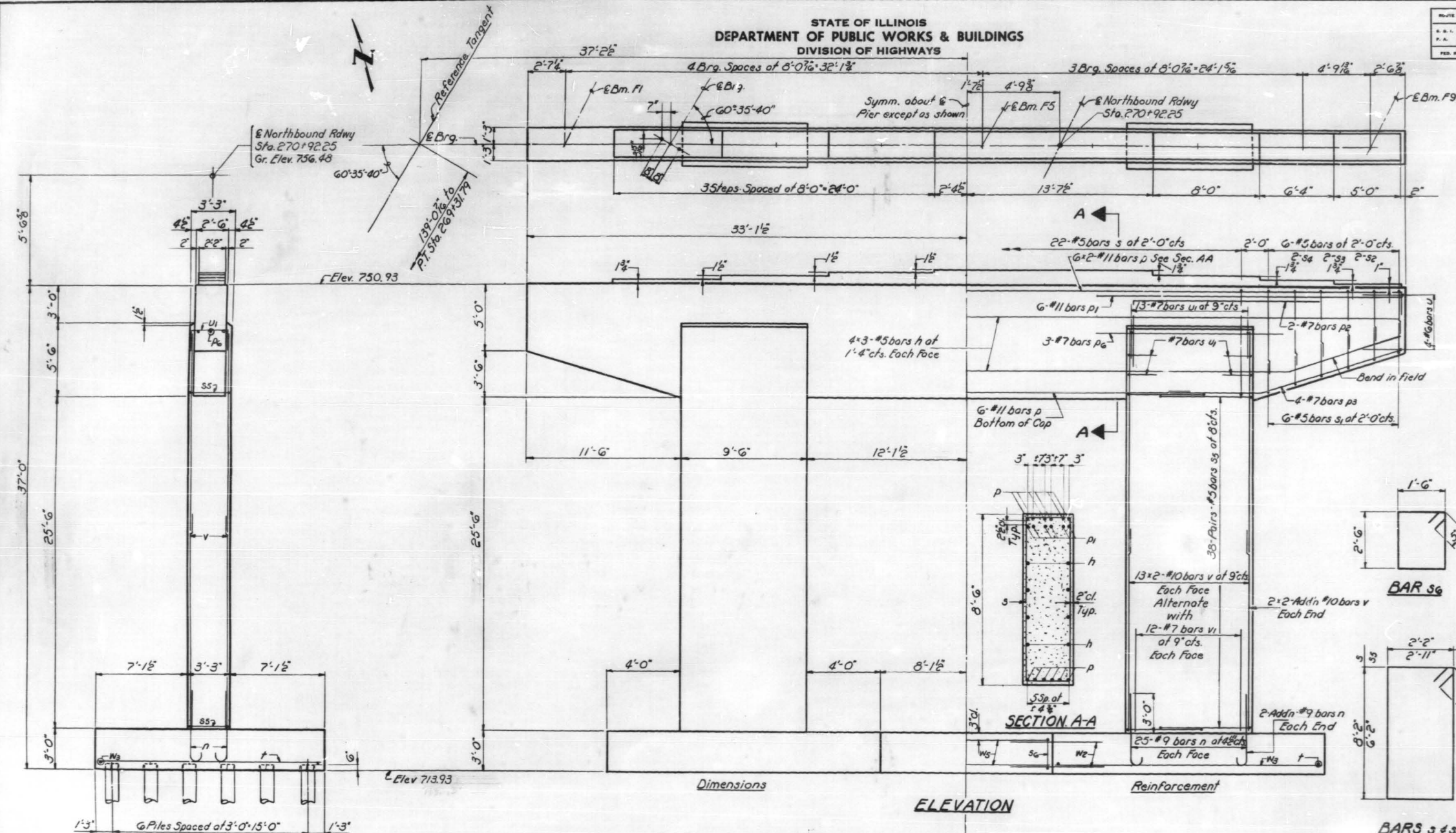

**BILL OF MATERIAL**

Bar	No	Size	Length	Shape
h	24	#5	24'-0"	—
n	108	#9	6'-3"	—
p	12	#11	37'-6"	—
p1	12	#11	23'-0"	—
p2	6	#7	19'-0"	—
p3	8	#7	18'-6"	—
p4	6	#11	34'-0"	—
p5	6	#7	14'-0"	—
s	22	#5	21'-8"	—
s1	12	#5	7'-2"	—
s2	4	#5	9'-2"	—
s3	4	#5	12'-2"	—
s4	4	#5	15'-2"	—
s5	152	#5	19'-2"	—
s6	9	#4	8'-10"	—
t	56	#11	17'-0"	—
u	3	#6	6'-1"	—
u1	34	#7	7'-0"	—
v	120	#10	16'-6"	—
v1	48	#7	7'-6"	—
w2	8	#9	6'-0"	—
w3	46	#9	17'-0"	—
w5	4	#9	15'-6"	—
Class X Concrete			Cu. Yds.	181.8
Reinforcement Bars			Lbs.	30410
Creosoted Piles			Lin. Ft.	2160

**FILE DATA**  
Type-Creosoted  
Capacity 20 Tons  
Est. Length 30'-0"  
No. Req'd 72

Add strut after footing and columns have been poured.

DESIGNED *James T. Pence*  
CHECKED *J. H. Nelson*  
DRAWN *W. E. Dickerson*  
CHECKED *J. N. P.*

EXAMINED *H. G. Baumann*  
PASSED *[Signature]*  
APPROVED *[Signature]*  
CHIEF HIGHWAY ENGINEER

JUNE 16 1964

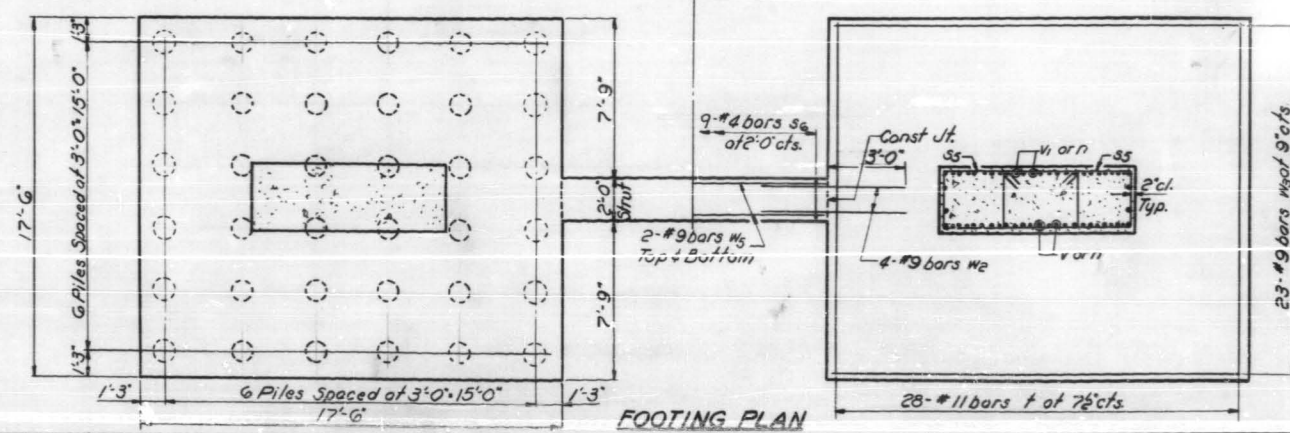

**PIER 5 NORTHBOUND**  
S.B.I. ROUTE 53  
SEC. 531-2-VHB  
COOK COUNTY  
STATION 270+71.17





STATE OF ILLINOIS  
DEPARTMENT OF PUBLIC WORKS & BUILDINGS  
DIVISION OF HIGHWAYS

ROUTE NO.	SECTION	COUNTY	TOTAL SHEETS	SHEET NO.
S. B. I. 53	531-2-VHB	COOK	62	62
SHEET NO. 57				
60 SHEETS				

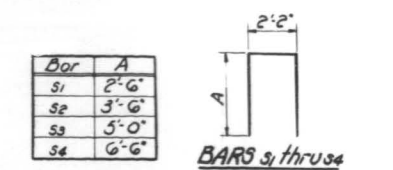
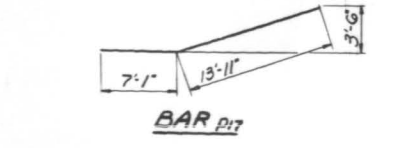
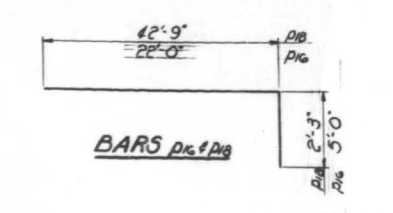
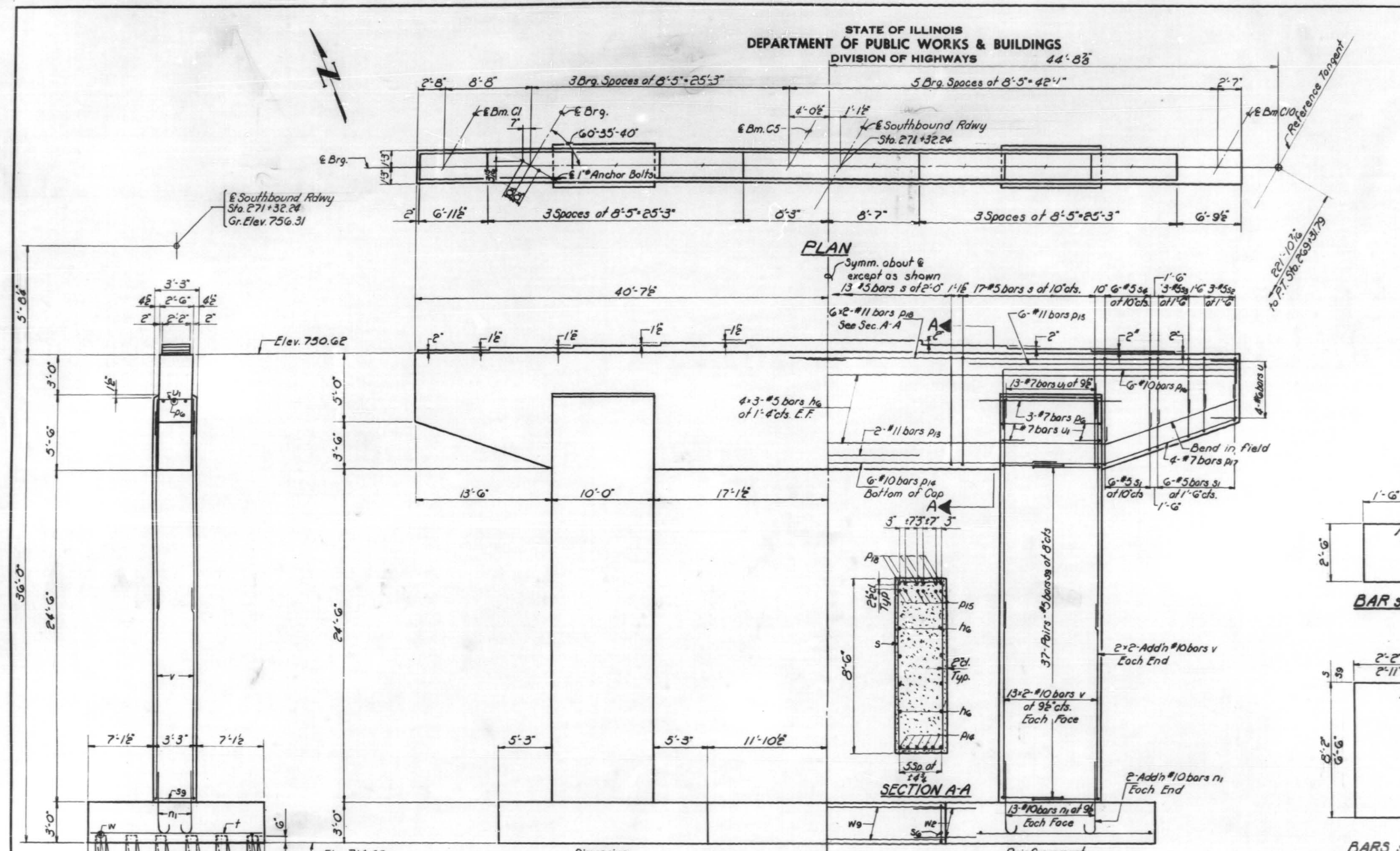

**BILL OF MATERIAL**

Bar No	Size	Length	Shape
h <sub>g</sub>	24 #5	27'-9"	—
n <sub>1</sub>	60 #10	7'-0"	—
p <sub>1c</sub>	6 #7	14'-0"	—
p <sub>1g</sub>	2 #11	18'-0"	—
p <sub>1s</sub>	6 #10	43'-0"	—
p <sub>1t</sub>	12 #11	29'-0"	—
p <sub>1v</sub>	12 #10	27'-0"	—
p <sub>1w</sub>	8 #7	21'-0"	—
p <sub>1x</sub>	12 #11	45'-0"	—
s	47 #5	21'-8"	□
s <sub>1</sub>	24 #5	7'-2"	□
s <sub>2</sub>	6 #5	9'-2"	□
s <sub>3</sub>	6 #5	12'-2"	□
s <sub>4</sub>	12 #5	15'-2"	□
s <sub>6</sub>	12 #4	8'-10"	□
s <sub>9</sub>	148 #5	19'-10"	□
t	66 #11	17'-0"	—
u	8 #6	8'-1"	□
u <sub>1</sub>	34 #7	7'-0"	□
v	120 #10	16'-6"	—
w	46 #9	20'-0"	—
w <sub>2</sub>	8 #9	6'-0"	—
w <sub>3</sub>	5 #9	23'-6"	—
Class X Concrete		Cu. Yds	2079
Reinforcement Bars		Lbs.	33,880
Crested Piles		Lin. Ft.	2688

**PILE DATA**  
Type: Creosoted  
Capacity: 20 Tons  
Est. Length: 32'-0"  
No. Req'd: 84

Note:  
Battered piles shall be driven with the bottom ends away from the adjoining abutment.

DESIGNED: J. B. R.  
CHECKED: James H. Pence  
DRAWN: W. E. Dickerson  
CHECKED: J. N. P.

EXAMINED: W. E. Blummann  
PASSED: [Signature]  
APPROVED: [Signature]

JUNE 16 1964

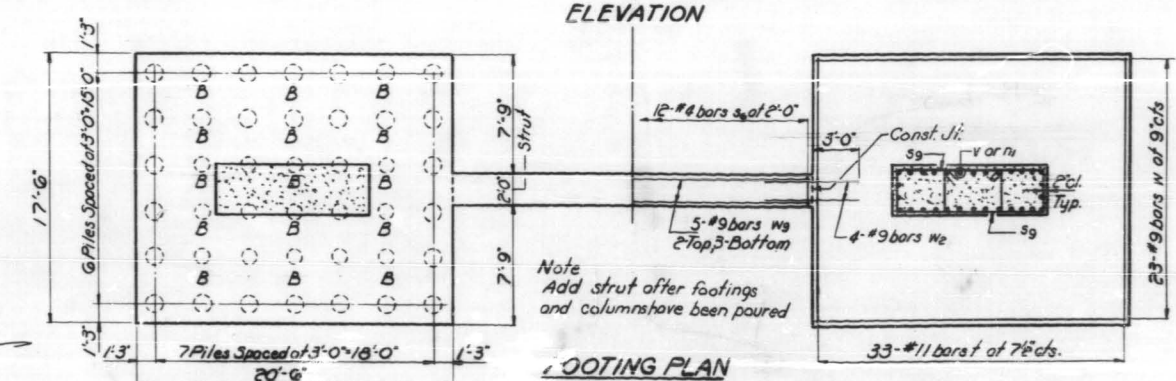

**PIER 6 SOUTHBOUND**  
S.B.I. ROUTE 53  
SEC. 531-2-VHB  
COOK COUNTY  
STATION 270+7.17



STATE OF ILLINOIS  
DEPARTMENT OF PUBLIC WORKS & BUILDINGS  
DIVISION OF HIGHWAYS

ROUTE NO.	SECTION	COUNTY	TOTAL SHEETS	SHEET NO.
53	531-2	COOK	67	63
SHEET NO. 58				
60 SHEETS				

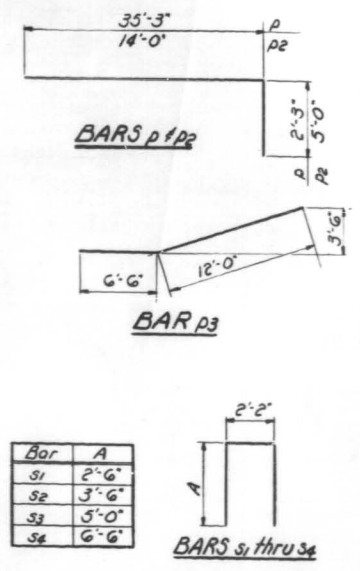
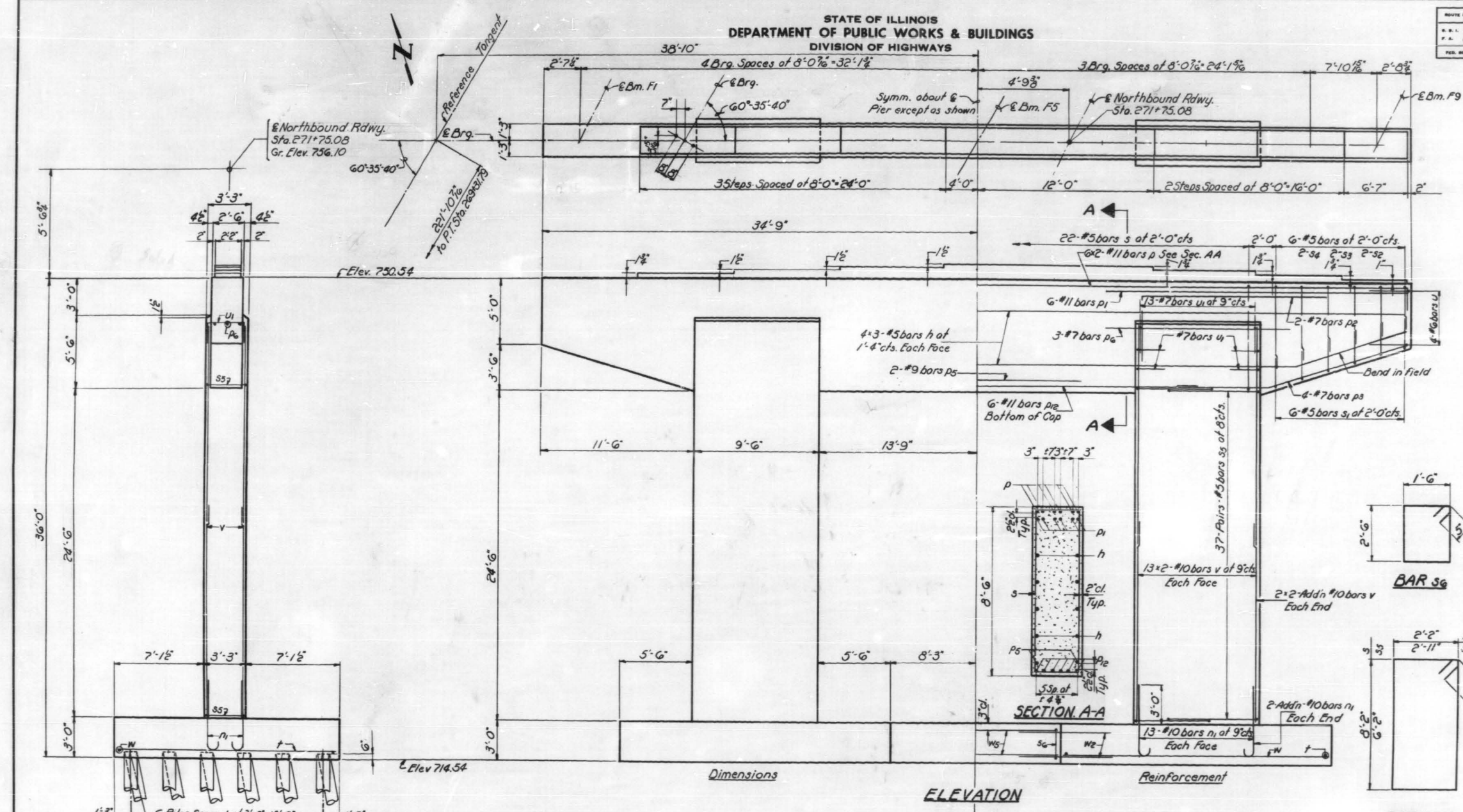

**BILL OF MATERIAL**

Bar	No	Size	Length	Shape
h	24	#5	24'-0"	—
n1	60	#10	7'-0"	C
p	12	#11	37'-6"	—
p1	12	#11	23'-0"	—
p2	4	#7	19'-0"	—
p3	8	#7	18'-6"	—
p5	2	#9	17'-0"	—
p6	6	#7	14'-0"	—
p7	6	#11	36'-6"	—
s	22	#5	21'-8"	□
s1	12	#5	7'-2"	□
s2	4	#5	9'-2"	□
s3	4	#5	12'-2"	□
s4	4	#5	15'-2"	□
s5	148	#5	19'-2"	□
s6	9	#6	8'-10"	□
f	66	#11	17'-0"	—
u	8	#6	8'-1"	□
u1	34	#7	7'-0"	□
v	120	#10	16'-6"	—
w	46	#9	20'-0"	—
w2	8	#9	6'-0"	—
w3	4	#9	15'-6"	—
Class X Concrete		Cu. Yds.	193.7	
Reinforcement Bars		Lbs.	30,490	
Creosoted Piles		Lin. Ft.	2608	

**END VIEW**

**PILE DATA**  
Type-Creosoted  
Capacity-20 Tons  
Est. Length-32'-0"  
No. Req'd-84

**NOTE:**  
Battered piles shall be driven with the bottom ends away from the adjoining abutment. Add strut after footing and columns have been poured.

DESIGNED J.B. Nelson  
CHECKED James M. Pence  
DRAWN W.F. Dickerson  
CHECKED J.N.P.

EXAMINED W.G. Braunstein  
PASSED  
APPROVED  
JUNE 16 1964

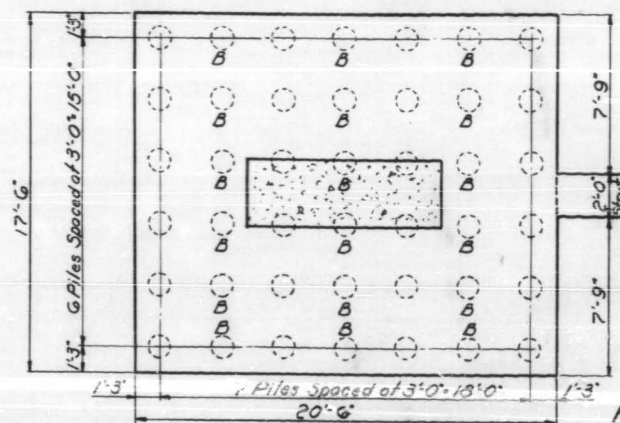

**FOOTING PLAN**

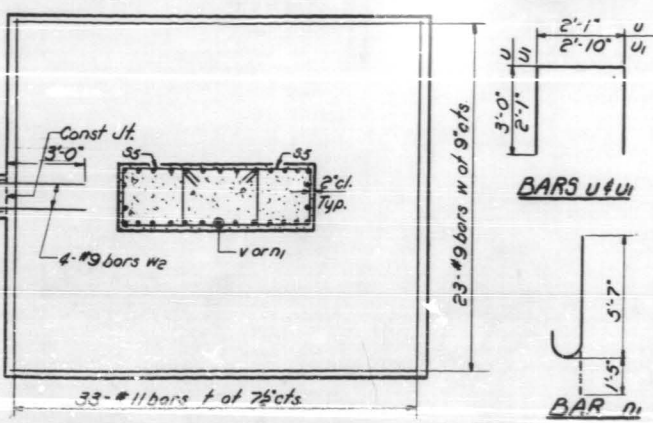

**PIER 6 NORTHBOUND**  
S.B.I. ROUTE 53  
SEC. 531-2-VHB  
COOK COUNTY  
STATION 270+71.17





STATE OF ILLINOIS  
DEPARTMENT OF PUBLIC WORKS & BUILDINGS  
DIVISION OF HIGHWAYS

ROUTE NO.	SECTION	COUNTY	TOTAL SHEETS	SHEET NO.	SHEET NO. 53
53	531-2	COOK	67	64	60 SHEETS
P.A. 61	-VHB				
DESIGNED BY	CHECKED BY	DRAWN BY	DATE	SCALE	PROJECT NO.

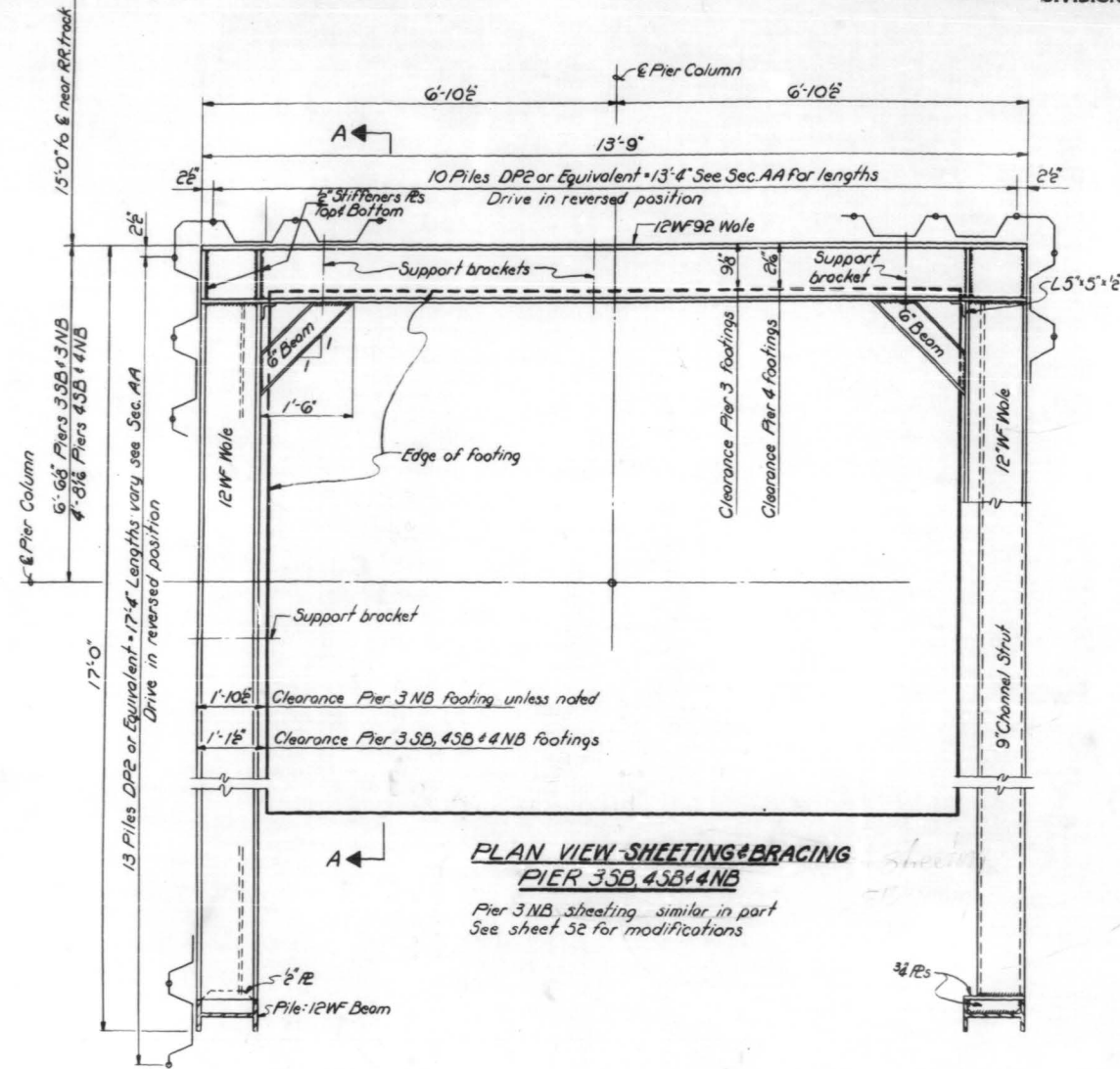

**PLAN VIEW SHEETING & BRACING  
PIER 3SB, 4SB & 4NB**

Pier 3 NB sheeting similar in part  
See sheet 52 for modifications

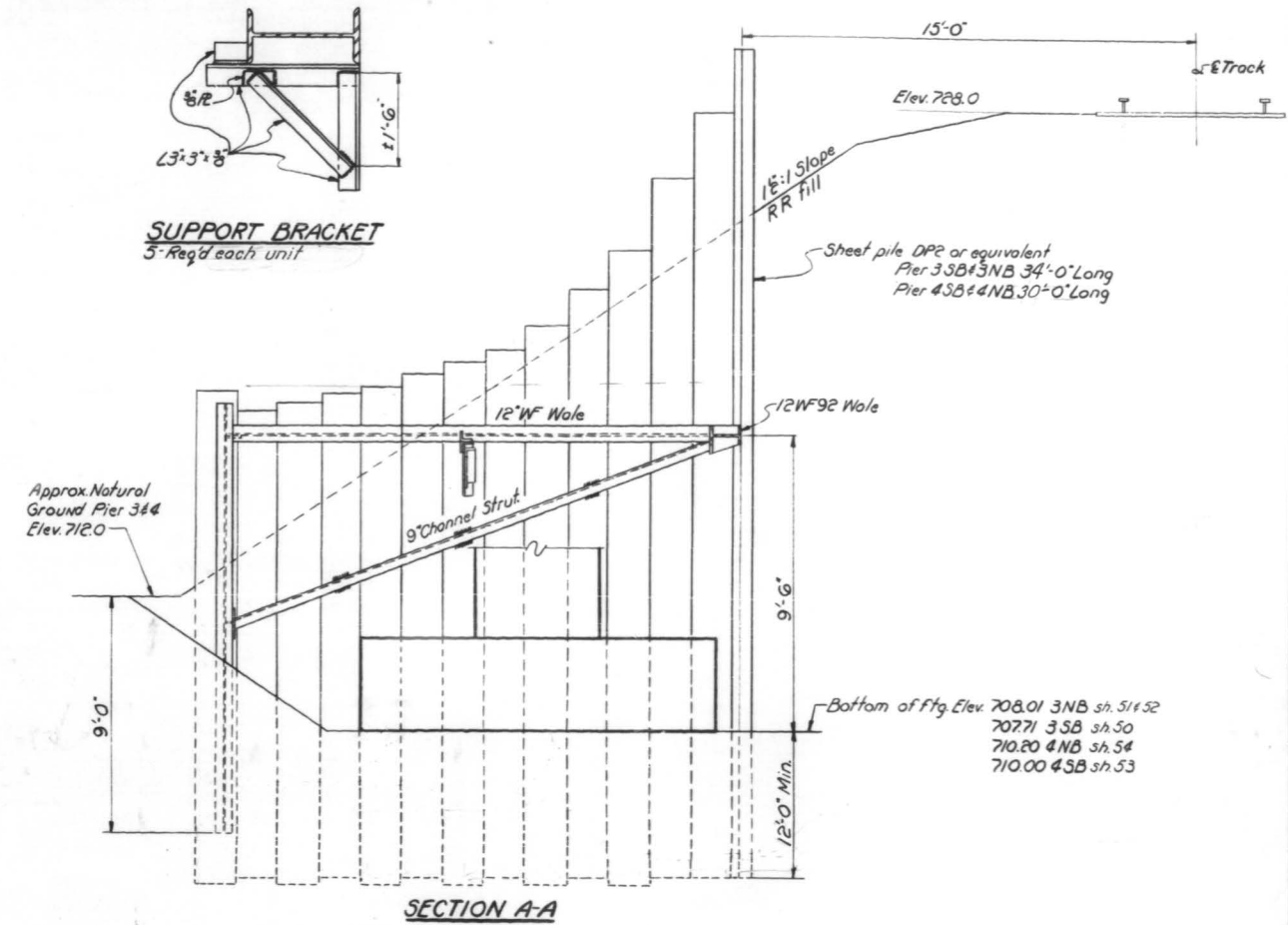

**SECTION A-A**

**CONSTRUCTION PROCEDURE**

1. Construct template for driving sheet piling parallel to railroad.
2. Drive sheet piling parallel to railroad.
3. Drive sheet piling and 12WF beam piles at end of sheeting.
4. Excavate to wale level, place wale assembly and support brackets.
5. Excavate along ends and attach struts.
6. Complete excavation & drive Precast Concrete footing piles

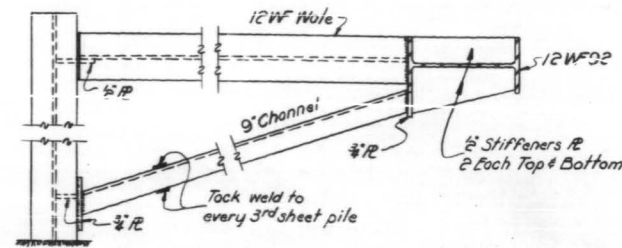

**END BRACING DETAILS**

DESIGNED	James H. Pence
CHECKED	James H. Pence
DRAWN	W.E. Dickerson
CHECKED	J.N.P.

EXAMINED	W.E. Dickerson	DATE	JUNE 16 1964
PASSED	W.E. Dickerson		
APPROVED	W.E. Dickerson		

**TEMPORARY SHEETING**  
S.B.I. ROUTE 53  
SEC. 531-2-VHB  
COOK COUNTY  
STATION 270+71.17

