

ELEVATION AT TERMINAL (SPECIAL)
(NW & SW ENDS)

(Corrugated beam guardrail connection for impact attenuator *)
(See Sheet 33 of 33 for attenuator connection plate details)

*Contractor shall verify hole requirements for the impact attenuator supplied prior to submitting shop drawings. See Note 4.

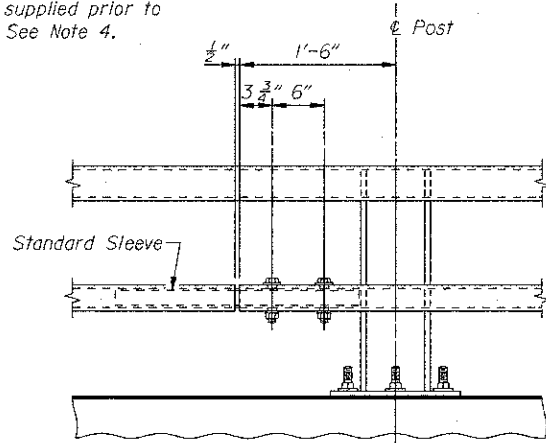

STANDARD SPLICE
(Top or bottom rail)

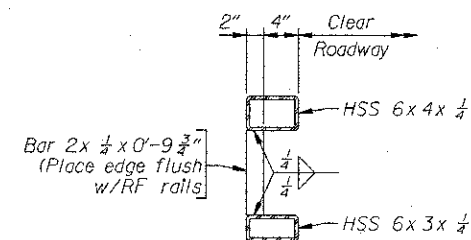

BRACE BAR DETAIL
(See Note No. 8)

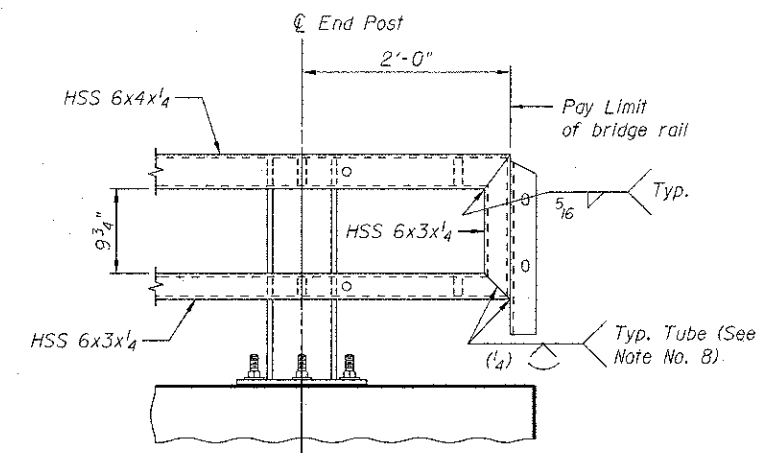

ELEVATION AT TERMINAL
TYPE 6A (SPECIAL)
(NE & SE ENDS)

(See Sheet 33 of 33 for guardrail connection plate details)

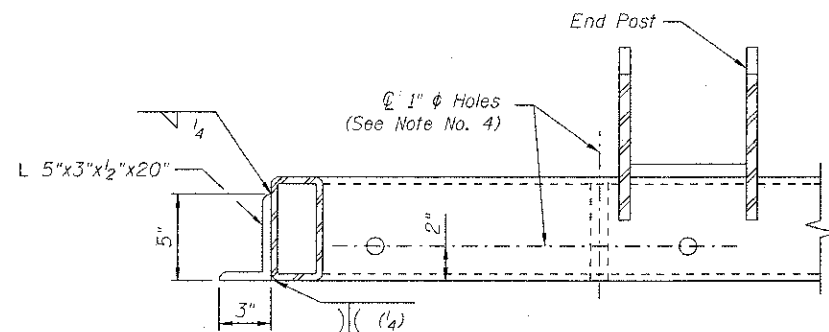

TOP VIEW
(NW & SW ENDS)

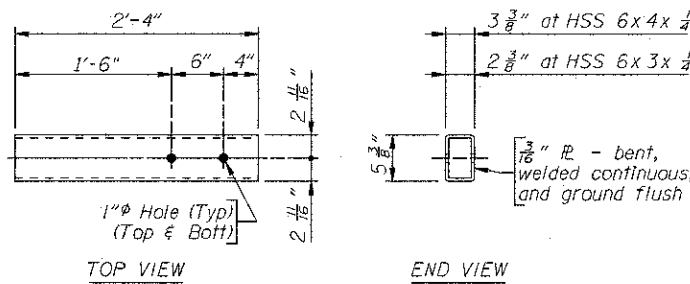

STANDARD SLEEVE DETAILS

Notes:

- 1) Splices may be located on either side of post.
- 2) Not more than one splice is permitted per side of post.
- 3) Do not shop splice rails.
- 4) Holes in steel railing may be field drilled for connection to Traffic Barrier Terminals. Any galvanized steel exposed or damaged by drilling operation shall be painted according to Article 509.05 of the Standard Specifications.
- 5) Either top or bottom rail in terminal section may be the longer rail.
- 6) Ensure each rail length is continuous over a minimum of two posts. Railing is continuous if either the top or bottom rail in the terminal is continuous over a minimum of two posts.
- 7) Ensure a brace bar is placed 2'-0" from the splice end of the shorter tube.
- 8) Ensure the fabricator prepares a sample of the indicated joint and it is macroetched to demonstrate that the required effective throat is achieved.
- 9) See Sheet 17 of 33 for rail post spacing.

BILL OF MATERIAL

Steel Railing (Special)	Foot	210
-------------------------	------	-----

(Sheet 2 of 2)

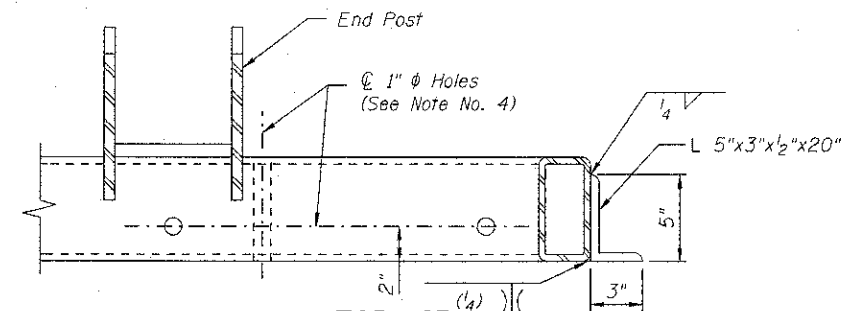

TOP VIEW
(NE & SE ENDS)

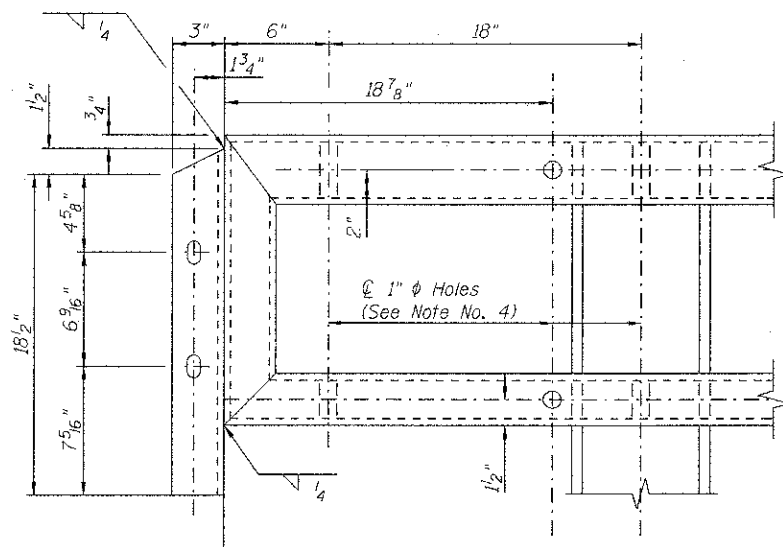

FRONT VIEW

END CONNECTION ANGLES
(NW & SW ENDS)

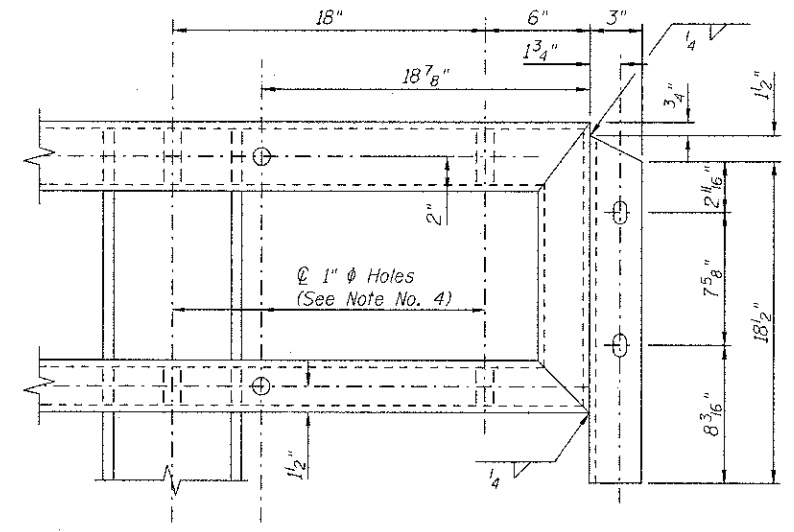

FRONT VIEW

END CONNECTION ANGLES
(NE & SE ENDS)

FILE NAME: s:\1755-012 Inverness phone\1755-012\structural\0563184-000-01.dwg