

EAST ABUTMENT BILL OF MATERIAL

| Bar | No. | Size | Length | Shape |
|---|-----|---------|---------|-------|
| h80(E) | 42 | #5 | 22'-3" | — |
| h81(E) | 84 | #5 | 24'-3" | — |
| h82(E) | 16 | #5 | 10'-4" | ↙ |
| h83(E) | 16 | #5 | 10'-4" | ↘ |
| h84(E) | 30 | #6 | 25'-3" | — |
| h85(E) | 10 | #6 | 27'-3" | — |
| h86(E) | 24 | #4 | 17'-8" | — |
| h87(E) | 10 | #4 | 16'-7" | — |
| h88(E) | 2 | #4 | 16'-4" | — |
| h89(E) | 10 | #4 | 18'-11" | — |
| h90(E) | 2 | #4 | 19'-0" | — |
| n80(E) | 31 | #6 | 13'-4" | — |
| n81(E) | 12 | #6 | 6'-8" | — |
| p80(E) | 20 | #7 | 32'-9" | — |
| p81(E) | 40 | #7 | 35'-9" | — |
| p82(E) | 6 | #7 | 17'-10" | — |
| p83(E) | 6 | #7 | 19'-6" | — |
| p89(E) | 12 | #5 | 22'-2" | — |
| p90(E) | 4 | #5 | 21'-8" | — |
| p91(E) | 4 | #5 | 5'-1" | — |
| p92(E) | 8 | #5 | 25'-9" | — |
| p93(E) | 4 | #5 | 16'-10" | — |
| p94(E) | 4 | #5 | 18'-5" | — |
| s80(E) | 325 | #4 | 15'-11" | □ |
| s81(E) | 55 | #4 | 9'-5" | □ |
| s82(E) | 2 | #4 | 21'-3" | □ |
| s83(E) | 175 | #5 | 8'-5" | □ |
| u80(E) | 20 | #6 | 12'-1" | — |
| u81(E) | 5 | #6 | 10'-10" | ↙ |
| u82(E) | 4 | #6 | 14'-9" | ↘ |
| v80(E) | 121 | #5 | 3'-9" | — |
| v81(E) | 189 | #4 | 3'-0" | — |
| v82(E) | 38 | #6 | 9'-10" | — |
| v83(E) | 6 | #6 | 9'-10" | — |
| v84(E) | 31 | #6 | 10'-0" | — |
| v85(E) | 189 | #5 | 8'-9" | — |
| v86(E) | 189 | #5 | 7'-5" | — |
| Structure Excavation | | Cu. Yd. | 874 | |
| Concrete Structures | | Cu. Yd. | 236.3 | |
| Reinforcement Bars, Epoxy Coated | | Pound | 22,770 | |
| Furnishing Metal Shell Piles 12" x 0.250" | | Foot | 2,414 | |
| Driving Piles | | Foot | 2,414 | |
| Test Pile Metal Shells | | Each | 1 | |
| Concrete Sealer | | Sq. Ft. | 1,711 | |

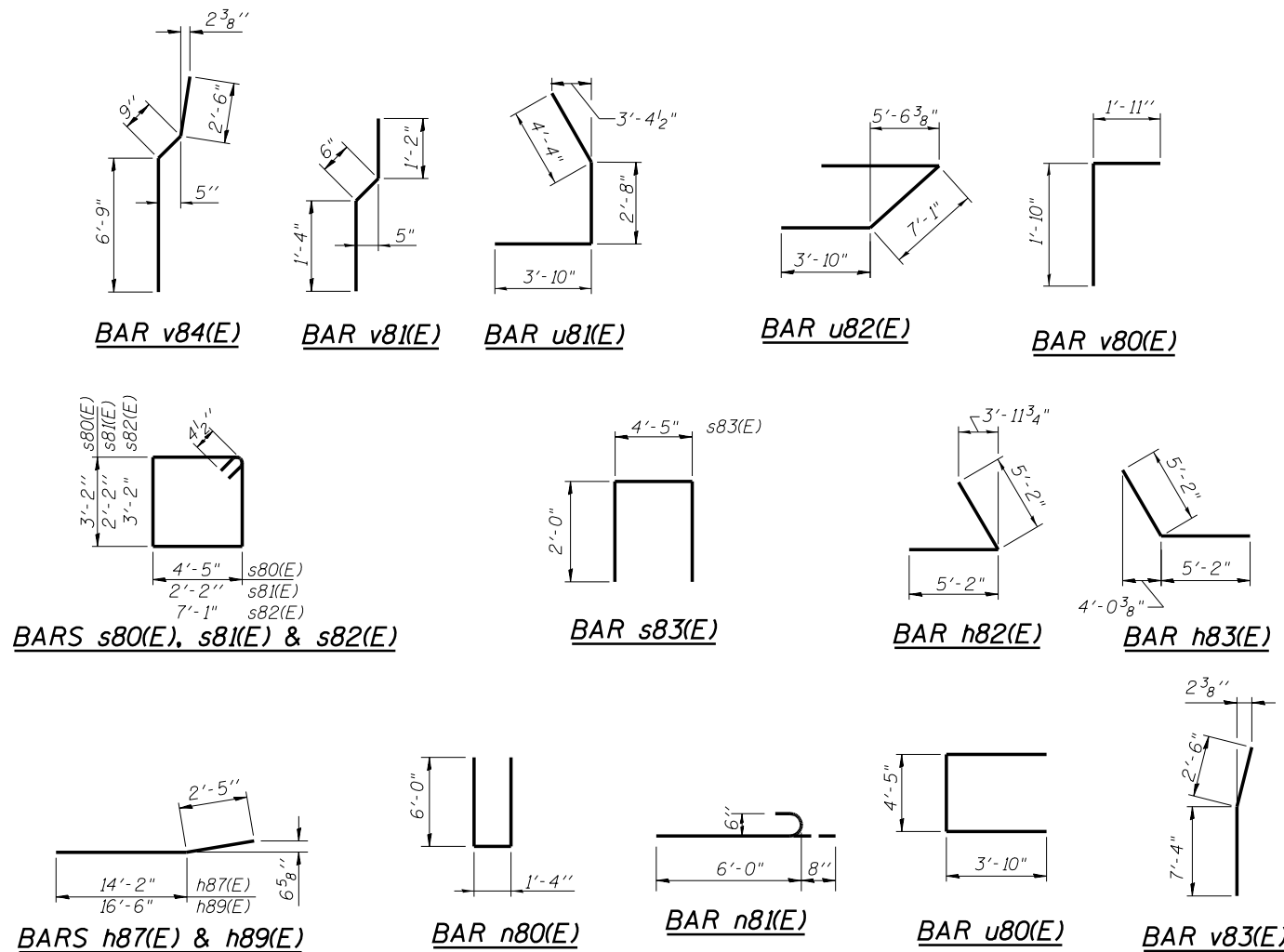

NOTES:

- Quantity of concrete in end post included with Concrete Superstructure on sheet SB17.
- For details of Bar Splicers, see sheet SB53.
- Quantity of concrete in hatch block included with Concrete Superstructure on sheet SB17.
- For details of piles, see sheet SB52.

benesch
engineers · scientists · planners
Alfred Benesch & Company
205 North Michigan Avenue, Suite 2400
Chicago, Illinois 60601
312-565-0450 Job No. 10056

| | | | |
|-----------------------------|---------------------|-----------------------|-----------|
| FILE NAME = | USER NAME = mbecker | DESIGNED - DTS | REVISED - |
| | | CHECKED - SLD | REVISED - |
| 0900167.68620.44.eabut7.dgn | | PLOT SCALE = | REVISOR = |
| | | PLOT DATE = 7/17/2012 | REVISOR = |

**STATE OF ILLINOIS
DEPARTMENT OF TRANSPORTATION**

**EAST ABUTMENT DETAILS 2 OF 2
STRUCTURE NO. 090-0167**

SHEET NO. SB44 OF SB65 SHEETS

| | | | | |
|--------------------|----------------------------|----------|---------------------------|-----------|
| F.A.I. RTE. | SECTION | COUNTY | TOTAL SHEETS | SHEET NO. |
| 74 | 90-[14R(14HB-4,14,14HV)BR] | TAZEWELL | 2433 | 1955 |
| CONTRACT NO. 68620 | | | ILLINOIS FED. AID PROJECT | |

x:\10000s\10056\engineer\ing-documents\phase-1\174over\Jefferson\Final\0900167_68620_44_eabut7.dgn 8:17:55 AM 7/17/2012