

STEEL POST CONSTRUCTION

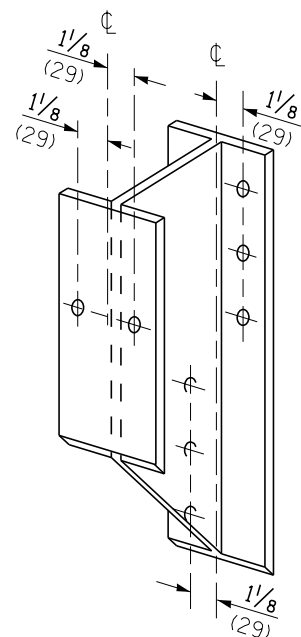

STEEL BLOCK-OUT DETAIL

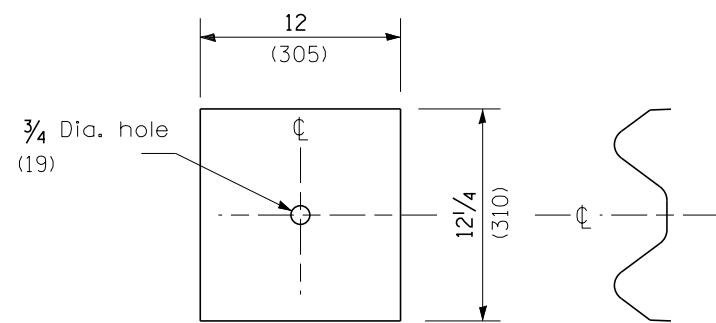

NOTE

Plate A shall be placed between rail element and block-out at non-splice mounting points only when steel block-outs are used.

PLATE A

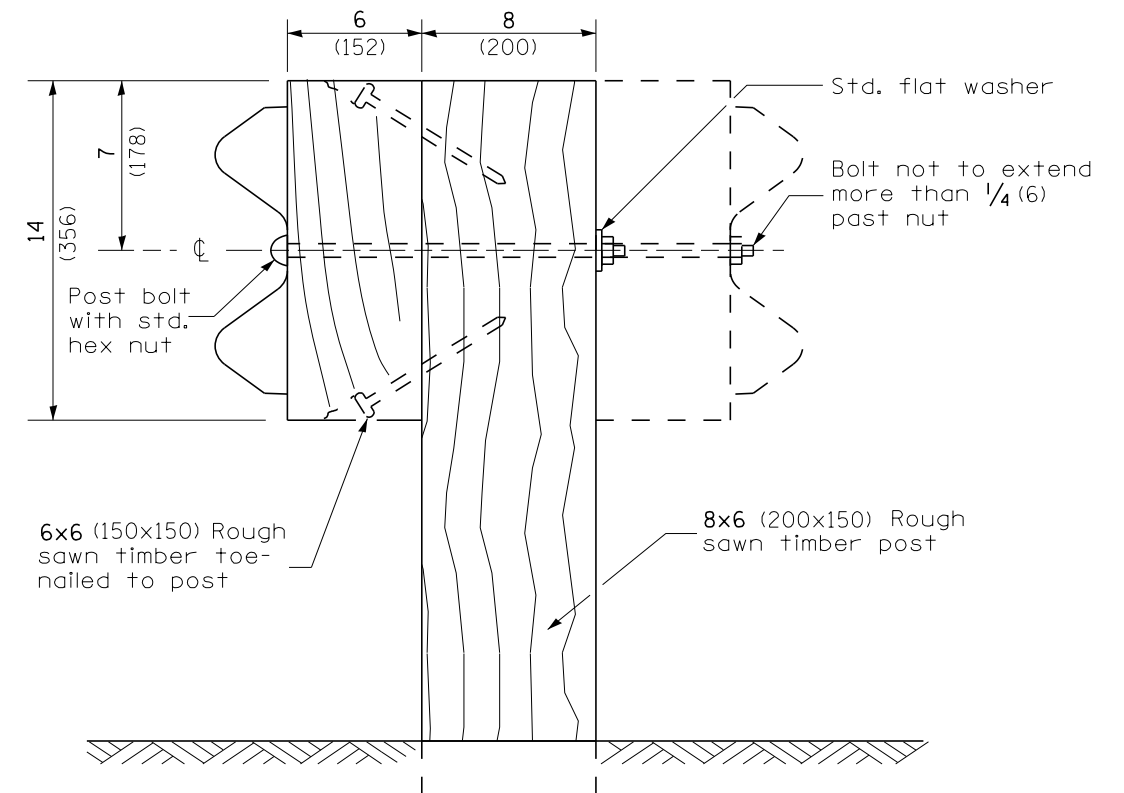

WOOD POST CONSTRUCTION

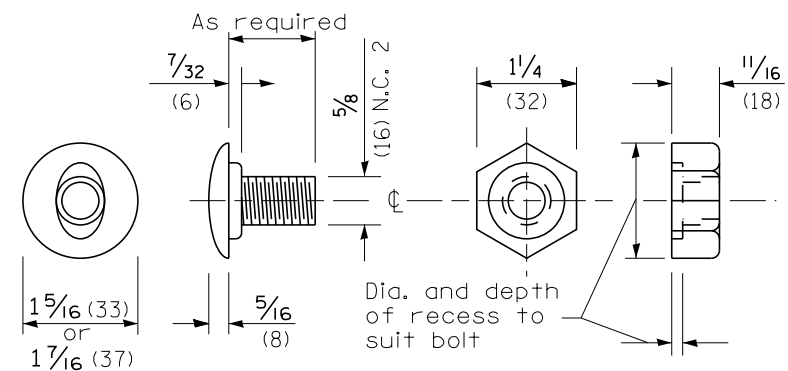

POST OR SPLICE BOLT & NUT

All dimensions are in inches (millimeters) unless otherwise noted.

STATE OF ILLINOIS
DEPARTMENT OF TRANSPORTATION

REMOVE AND REERECT STEEL PLATE BEAM GUARDRAIL
NOT TO SCALE

F.A.I. RTE.	SECTION	COUNTY	TOTAL SHEETS	SHEET NO.
90-114R(14HB-4,14,14HVB)BR		TAZEWELL	2433	2123
FED. ROAD DIST. NO. ILLINOIS FED. AID PROJECT			CONTRACT NO. 68620	