

DETAIL
(F.E. 1084+22.3)

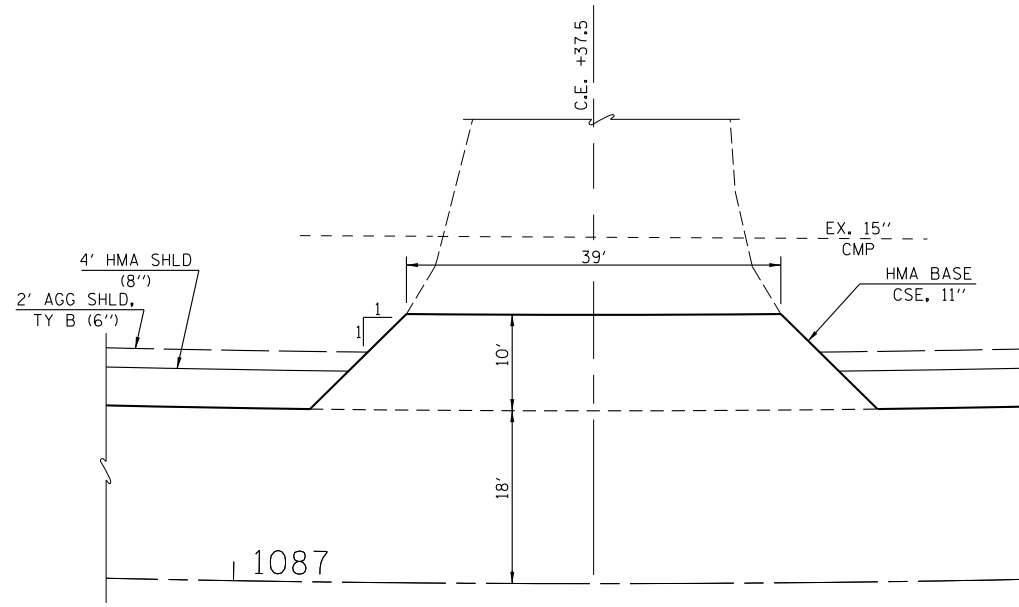

DETAIL
(C.E. 1087+37.5)

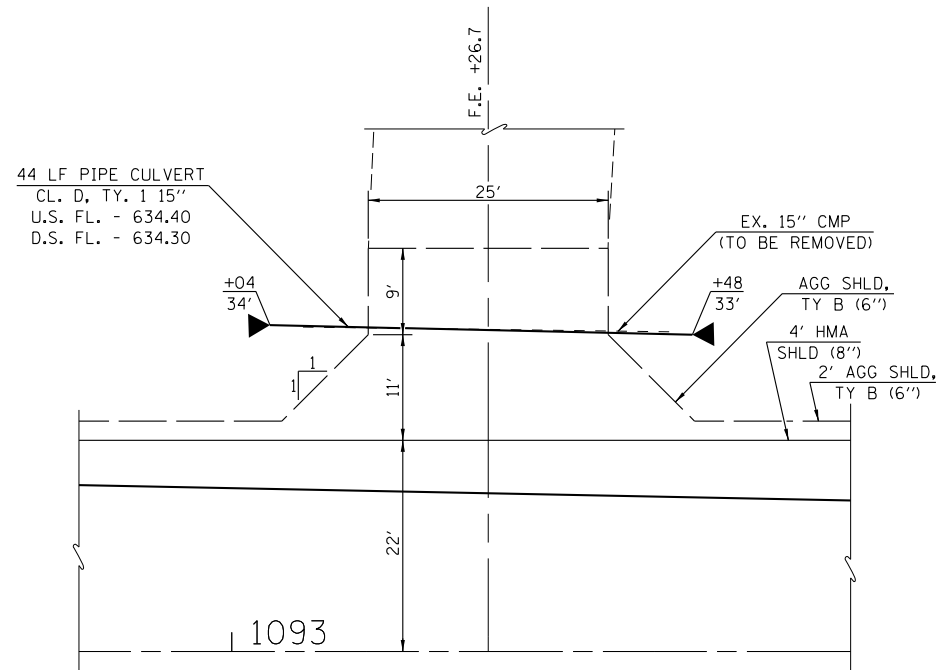

DETAIL
(F.E. 1093+26.7)

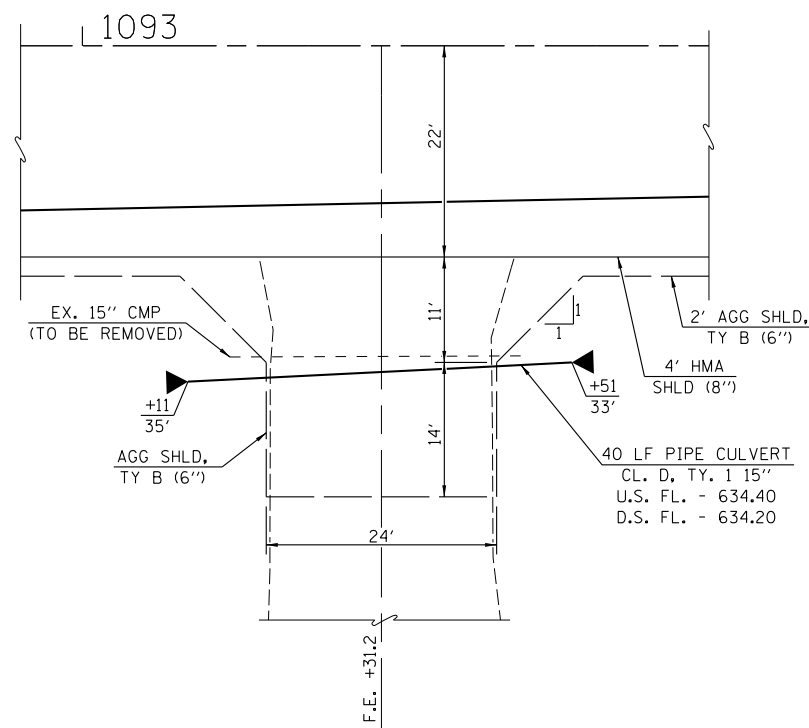

DETAIL
(F.E. 1093+31.2)

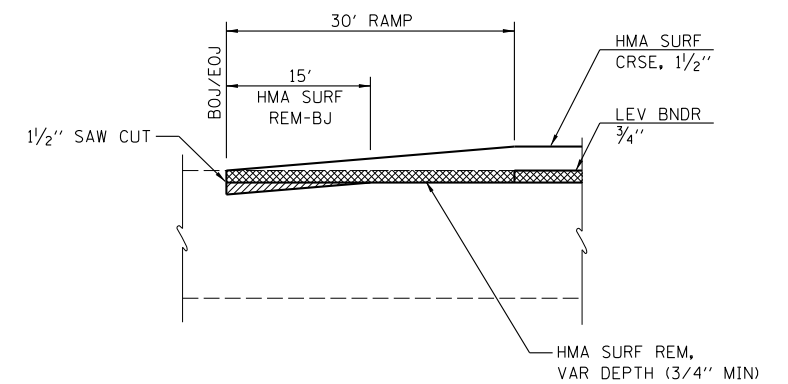

BUTT JOINT DETAILS
(MAINLINE)

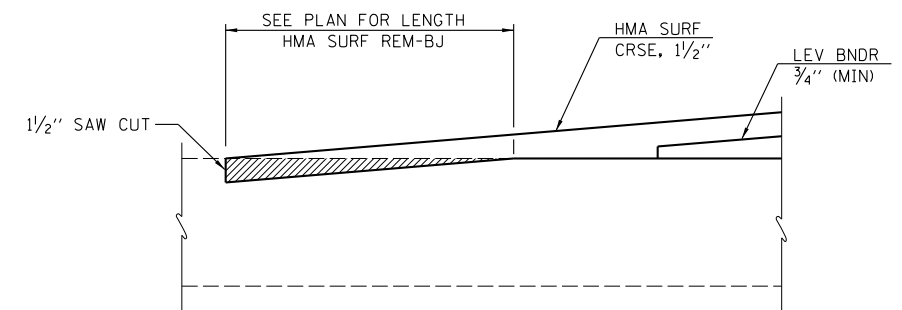

BUTT JOINT DETAILS
(SIDE ROADS)

USER NAME = *USER*	DESIGNED -	REVISED -
PLOT SCALE = *SCALE*	DRAWN -	REVISED -
PLOT DATE = *DATE*	CHECKED -	REVISED -
	DATE -	REVISED -



Allen Henderson & Associates, Inc.
Civil and Structural Engineers Springfield, IL
62703 Phone: (217)544-8033 IL Design Firm
No. 184-001907

ENTRANCE & BUTT JOINT DETAILS

SCALE: SHEET NO. 1 OF 1 SHEETS STA. TO STA.

F.A.P. RTE.	SECTION	COUNTY	TOTAL SHEETS	SHEET NO.
67	3 (N, L, RS-3)	CASS	64	32
CONTRACT NO. 72075				
FED. ROAD DIST. NO. ILLINOIS FED. AID PROJECT				