

TYPICAL CROSS SECTION

STATION 120+45 TO STATION 122+01

S.N. 018-0045 (W.B.)

R.R.

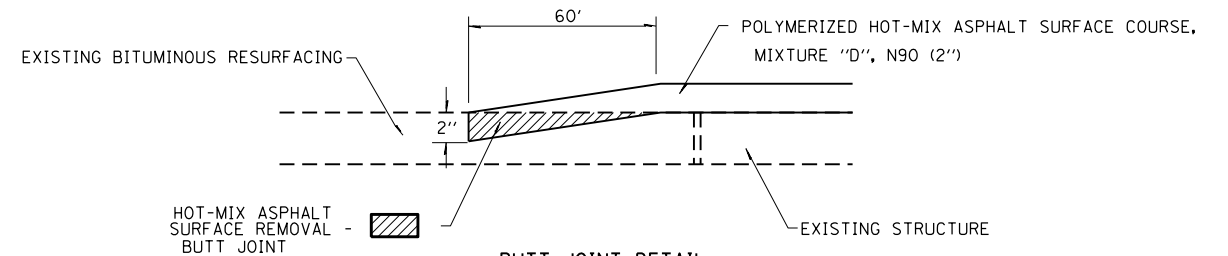
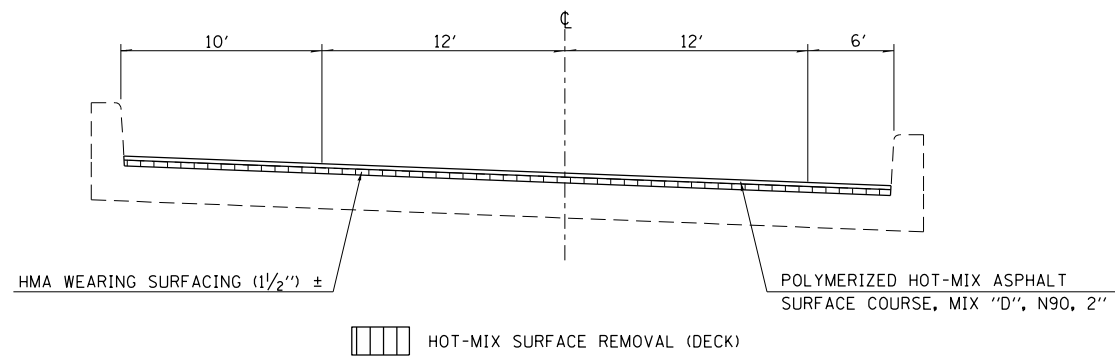

BUTT JOINT DETAIL

AT IL 121 BRIDGE
STA 141+41 TO STA 142+01
STA 143+38 TO STA 143+98

AT EMBARRASS RIVER BRIDGE
STA 154+27 TO STA 154+87
STA 161+57 TO STA 162+17

TYPICAL CROSS SECTION

STATION 142+01 TO STATION 143+38

S.N. 018-0047 (W.B.)

IL. RTE. 121

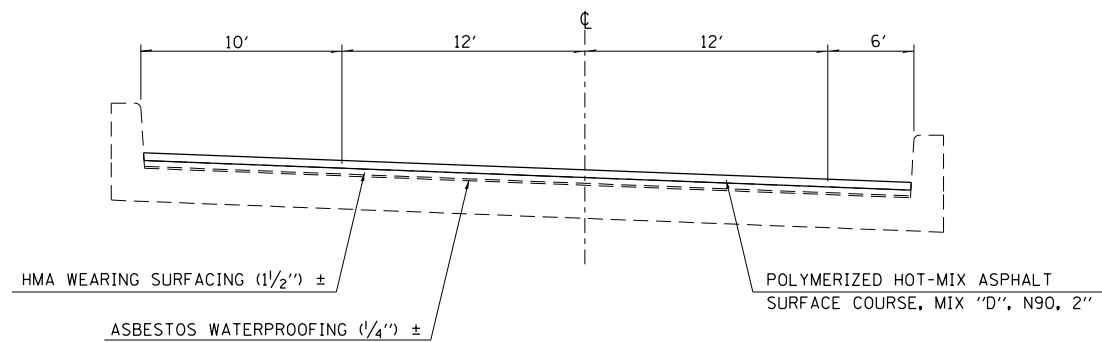

TYPICAL CROSS SECTION

STATION 154+87 TO STATION 161+57

S.N. 018-0049 (W.B.)

EMBARRASS RIVER

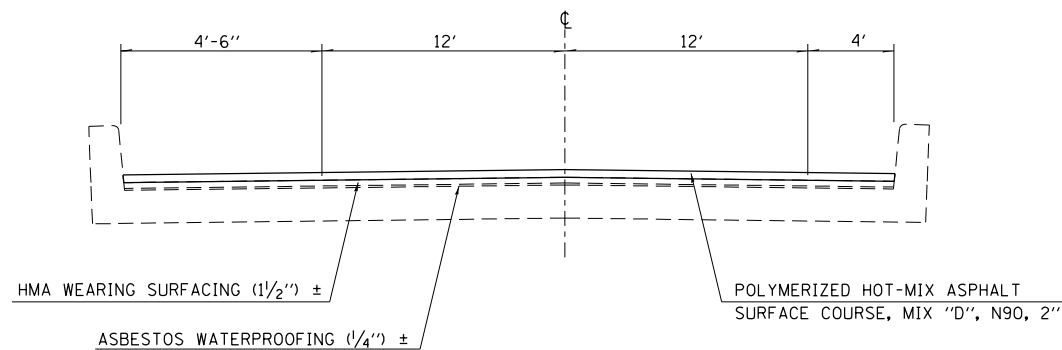

PRE-STAGE 1 BRIDGE WORK

STATION TO STATION	LENGTH FOOT	WIDTH OF RESURFACING (BRIDGE WIDTH/PAVEMENT PLUS HMA SHOULDERS) FOOT	HOT-MIX SURFACE REMOVAL (DECK) SQ YD	HOT-MIX SURFACE REMOVAL - BUTT JOINT SQ YD	DECK SLAB REPAIR (PARTIAL) SQ YD	DECK SLAB REPAIR (FULL DEPTH TYPE I) SQ YD	DECK SLAB REPAIR (FULL DEPTH TYPE II) SQ YD	POLYMERIZED HMA SURFACE, MIX "D", N90 TON	BITUMINOUS MATERIALS (PRIME COAT) GALLON
ABANDONED RR BRIDGE									
SN 018-0045 (W. B.)									
120+45 TO 122+01	156.0	40.0	693		11	3	6	78	69
IL 121 BRIDGE									
SN 018-0047 (W. B.)									
141+41 TO 142+01	60.0	40.0		267				30	27
142+01 TO 143+38	138.5	40.0			84	21	42	69	62
143+38 TO 143+98	60.0	40.0		267				30	27
EMBARRASS RIVER BRIDGE									
SN 018-0049 (W. B.)									
154+27 TO 154+87	60.0	32.5-40		242				27	24
154+87 TO 161+57	670.0	32.5			162	41	81	271	241
161+57 TO 162+17	60.0	32.5-40		242				27	24
TOTALS			693	1018	257	65	130	532	474

NOTES: WORK SHALL BE COMPLETED IN DRIVING LANE FIRST
SN 018-0045: TRAFFIC SHALL NOT BE ALLOWED ON BARE CONCRETE DECK.
SN 018-0047: PROTECTIVE SHIELD WILL BE REQUIRED AND PAID FOR IN THIS STAGE. PROTECTIVE SHIELD WILL NOT BE PAID FOR AGAIN IF CONTRACTOR ELECTS TO REMOVE SHIELD PRIOR TO STAGE 2.

NOTE: NOT TO SCALE

FILE NAME =	USER NAME = steffenmk	DESIGNED -	REVISED -
ci:\pw\work\p1dot\steffenmk\d0186453\d74466-sh1-prestage1.dgn		DRAWN -	REVISED -
	PLOT SCALE = 100.0000' / 1".	CHECKED -	REVISED -
	PLOT DATE = 8/20/2012	DATE -	REVISED -

**STATE OF ILLINOIS
DEPARTMENT OF TRANSPORTATION**

PRE-STAGE 1 DETAILS

SCALE: NA SHEET NO. 1 OF 2 SHEETS STA. TO STA.

• (18-47-VBK,(18-47B,18-47B)BR

F.A.I. RTE.	SECTION	COUNTY	TOTAL SHEETS	SHEET NO.
70	•	CUMBERLAND	147	26
			CONTRACT NO. 74466	
ILLINOIS FED. AID PROJECT				