

**CURB WALL DETAIL**

• Slope 2:1 (V:H) or as approved by Engineer

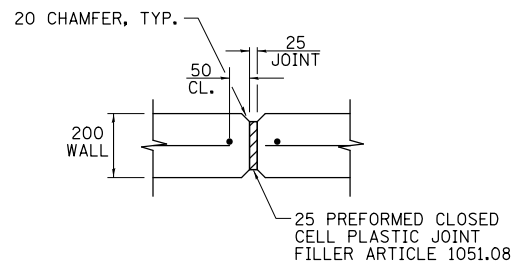

**EXPANSION JOINT DETAIL**

**MIN. BAR LAP**

#13 BAR = 1'-9"

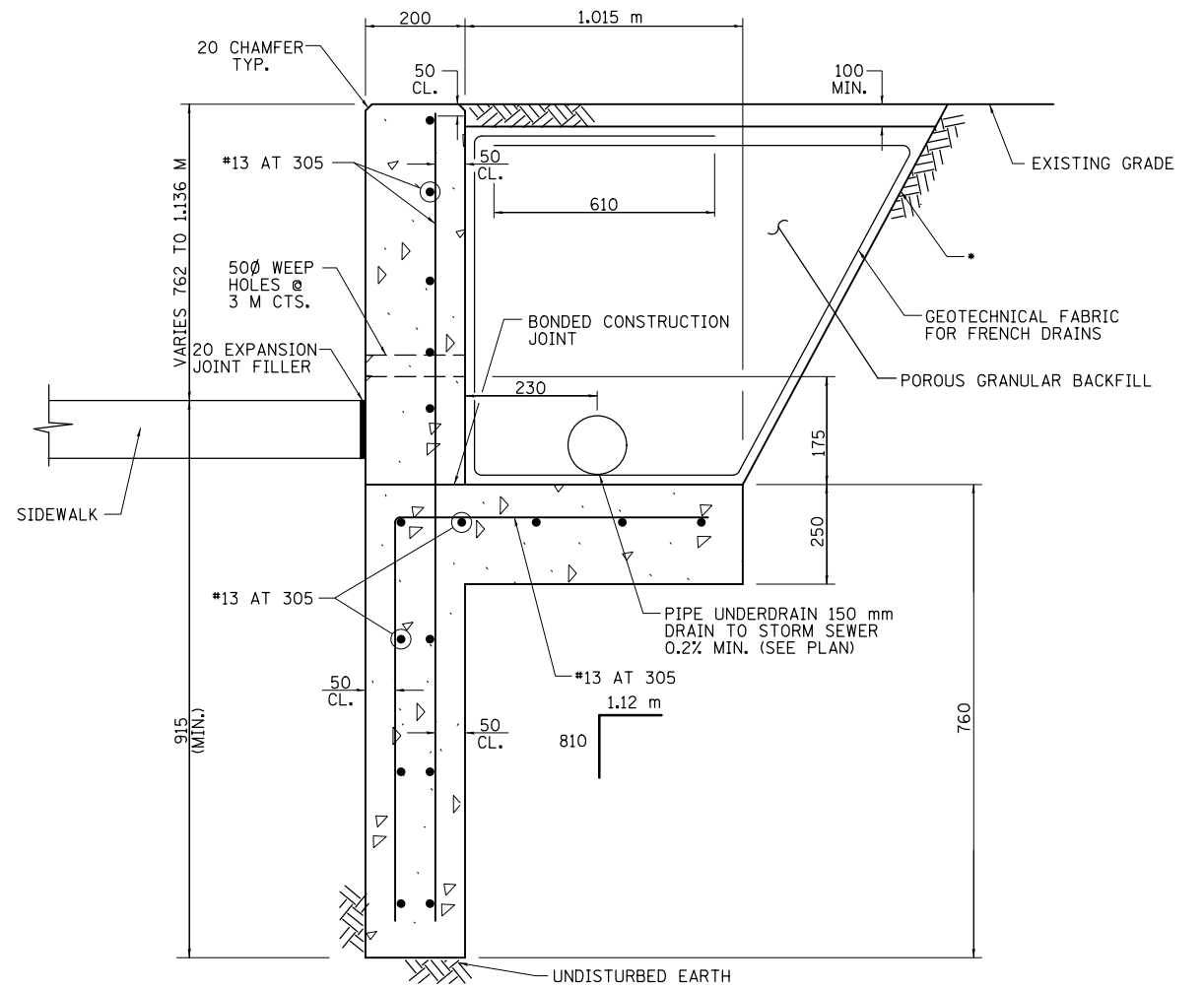

**RETAINING WALL DETAIL**

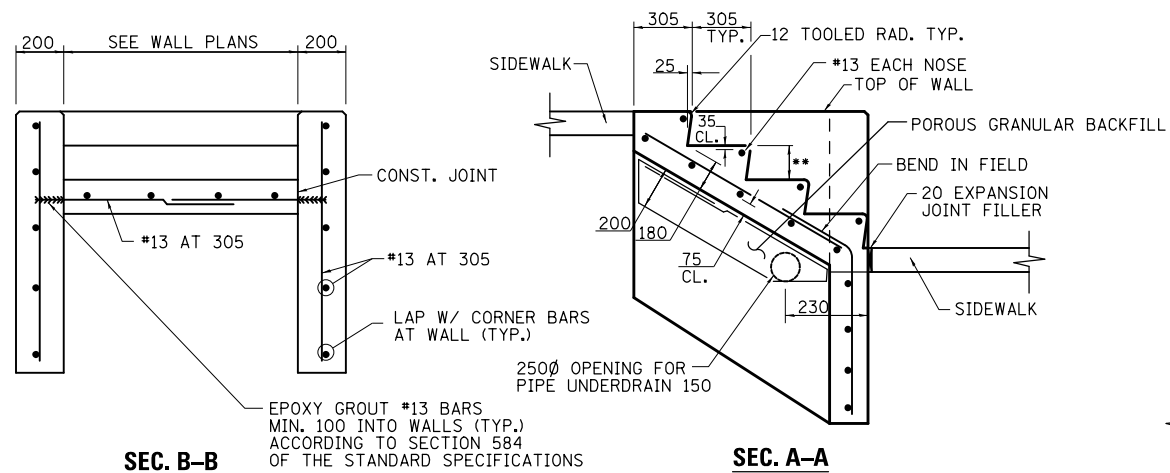

**SEC. B-B**

**SEC. A-A**

\*\* SEE WALL ELEVATIONS

**STEP DETAILS**

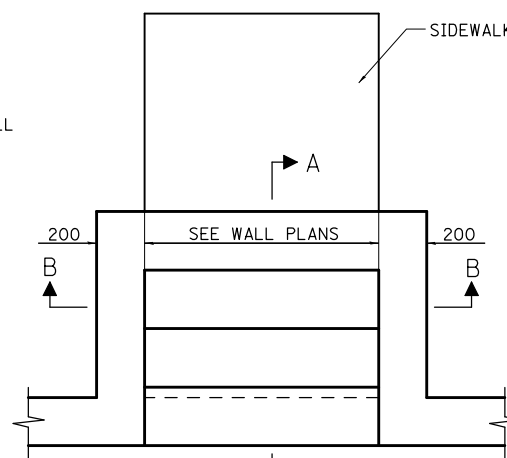

**TYPICAL PLAN**

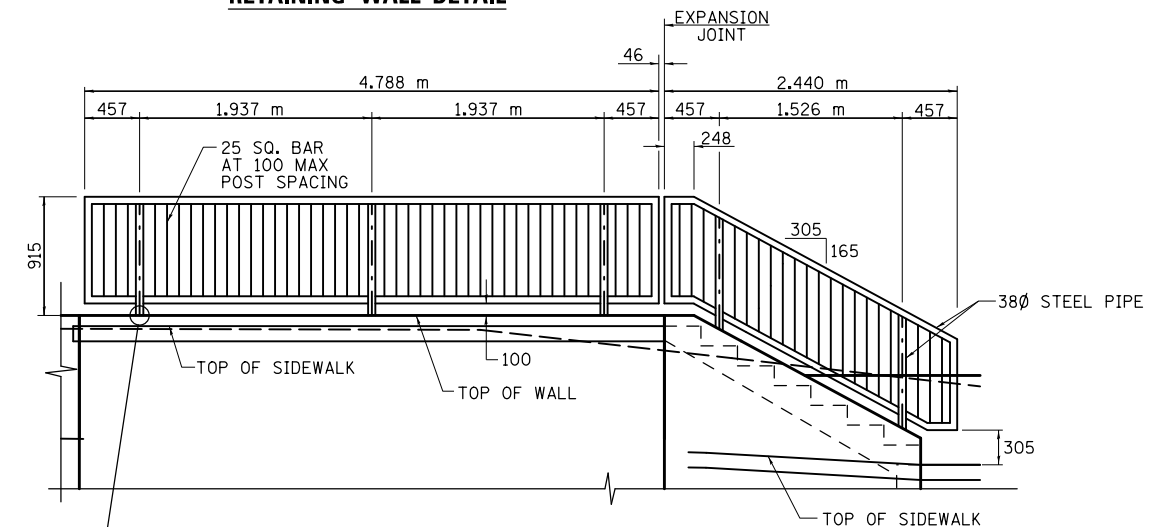

**PIPE HANDRAIL DETAIL**

NOTE: ALL DIMENSIONS ARE IN MILLIMETERS (MM) EXCEPT AS NOTED.

FILE NAME =	USER NAME = ceerlockjd	DESIGNED -	REVISED -
ce:\pw\work\p\midot\ceerlockjd\0313241\090939\RetainWallDetails.dgn		DRAWN -	REVISED -
		CHECKED -	REVISED -
		DATE -	REVISED -

STATE OF ILLINOIS  
DEPARTMENT OF TRANSPORTATION

WALL AND RAILING DETAILS

SCALE: SHEET NO. 2 OF 19 SHEETS STA. TO STA.

F.A.P. RTE.	SECTION	COUNTY	TOTAL SHEETS	SHEET NO.
729	36(W,RS-1) & 34Z-2(W,R	VERMILION	298	135
CONTRACT NO. 90939				
ILLINOIS FED. AID PROJECT				