**STRUCTURE GEOTECHNICAL REPORT
CIRCLE INTERCHANGE RECONSTRUCTION
RETAINING WALL 14 (PROPOSED SN 016-1803)
F.A.I ROUTE 94, (I-290 WB TO I-90/94 SB)
IDOT D-91-227-13/ PTB 163-001
COOK COUNTY, ILLINOIS**

**For
AECOM
303 East Wacker Drive
Chicago, IL 60601
(312) 938-0300**

**Submitted by
Wang Engineering, Inc.
1145 North Main Street
Lombard, IL 60148
(630) 953-9928**

**Original: August 25, 2017
Revised: April 30, 2018**

Technical Report Documentation Page

1. Title and Subtitle Structure Geotechnical Report Circle Interchange Reconstruction Retaining Wall 14, F.A.I. Route 94 Station 1229+52.25 to Station 1232+71.24		2. Report Date Original: August 25, 2017 Revised: April 30, 2018						
4. Route / Section / County FAI 94/2014-013R&B -R/ Cook		3. Report Type <input checked="" type="checkbox"/> SGR <input type="checkbox"/> RGR <input type="checkbox"/> Draft <input checked="" type="checkbox"/> Final <input checked="" type="checkbox"/> Revised						
6. PTB / Item No. 163/001	7. Existing Structure Number(s) No existing wall	5. IDOT Job No./Contract D-91-259-12/60X93						
8. Proposed Structure Number(s) 016-1803	<table style="width: 100%; border: none;"> <tr> <td style="width: 33%; border: none;"> 9. Prepared by Wang Engineering, Inc. 1145 N Main Street Lombard, IL 60148 </td> <td style="width: 33%; border: none;"> Contributor(s) Author: Metin W. Seyhun, P.E. QC/QA: Mohammed Kothawala, P.E., D.GE. PIC: Corina T. Farez, P.E., P.G. </td> <td style="width: 33%; border: none;"> Author Phone Number/Email Address (630) 953-9928 Ext 1018 mseyhun@wangeng.com </td> </tr> <tr> <td style="border: none;"> 10. Prepared for AECOM 303 East Wacker Drive Chicago, IL 60601 </td> <td style="border: none;"> Structural Engineer Matt Santeford, P.E., S.E. TranSystems </td> <td style="border: none;"> Contact Phone Number (847) 407-5235 </td> </tr> </table>		9. Prepared by Wang Engineering, Inc. 1145 N Main Street Lombard, IL 60148	Contributor(s) Author: Metin W. Seyhun, P.E. QC/QA: Mohammed Kothawala, P.E., D.GE. PIC: Corina T. Farez, P.E., P.G.	Author Phone Number/Email Address (630) 953-9928 Ext 1018 mseyhun@wangeng.com	10. Prepared for AECOM 303 East Wacker Drive Chicago, IL 60601	Structural Engineer Matt Santeford, P.E., S.E. TranSystems	Contact Phone Number (847) 407-5235
9. Prepared by Wang Engineering, Inc. 1145 N Main Street Lombard, IL 60148	Contributor(s) Author: Metin W. Seyhun, P.E. QC/QA: Mohammed Kothawala, P.E., D.GE. PIC: Corina T. Farez, P.E., P.G.	Author Phone Number/Email Address (630) 953-9928 Ext 1018 mseyhun@wangeng.com						
10. Prepared for AECOM 303 East Wacker Drive Chicago, IL 60601	Structural Engineer Matt Santeford, P.E., S.E. TranSystems	Contact Phone Number (847) 407-5235						
11. Abstract <p>As part of retaining Wall 14, 440.5 feet of walls will be constructed to retain the proposed WS Ramp Bridge south approach. The walls will consist of two different types, namely, 255.4 feet of Mechanically Stabilized Earth (MSE) wall with 17.4 feet maximum retained height, and 185.1 feet of Drilled Soldier Pile wall with 22.8 feet maximum retained height. This report provides geotechnical recommendations for the design and construction of the proposed retaining walls.</p> <p>Beneath the pavement or topsoil, the subsurface soils consists of up to 9 feet of fill materials, up to 6 feet medium stiff to very stiff clay crust, up to 40 feet of very soft to medium stiff silty clay, 10 feet of very stiff to hard clay loam, and 40 feet of hard silty clay loam or dense to very dense silt to silty loam and sand extending to the boring termination depths or weathered bedrock. Sound bedrock was encountered at an elevation of about 492 feet. Groundwater was encountered within the fill layers at elevations of 580 to 587 feet. Water-bearing layers are also present at deeper levels within the granular materials and weathered dolostone.</p> <p>Based on the encountered subsoil conditions and the wall heights, an MSE wall with Class IV LCCF backfill is feasible for the end sections, but the remaining sections with the highest wall heights will be constructed of drilled soldier pile and lagging backfilled with expanded polystyrene (EPS) blocks to avoid interference with the overlapping existing wall 12 footings on deep foundations.</p> <p>We estimate the wall foundation soils will have a maximum factored bearing resistance of 2,000 psf using a geotechnical resistance factor of 0.65. The maximum long-term consolidation settlement of foundation soils carrying the retaining wall embankment is estimated to be less than 1 inch. Global stability is not a concern.</p>								
12. Path to archived file S:\Netprojects\11000401\Reports\SGRs\Walls\1803 Wall 14\RPT_Wang_MWS_11000401SGRRevisedFinalWall14_20180430.doc								

TABLE OF CONTENTS

1.0	INTRODUCTION	1
1.1	PROJECT DESCRIPTION	1
1.2	PROPOSED STRUCTURE	2
1.3	EXISTING STRUCTURE	2
2.0	SITE CONDITIONS AND GEOLOGICAL SETTING	2
2.1	PHYSIOGRAPHY	3
2.2	SURFICIAL COVER	3
2.3	BEDROCK	3
3.0	METHODS OF INVESTIGATION	4
3.1	SUBSURFACE INVESTIGATION	4
3.2	VANE SHEAR TESTS	5
3.3	LABORATORY TESTING	5
4.0	RESULTS OF FIELD AND LABORATORY INVESTIGATIONS	5
4.1	SOIL CONDITIONS.....	6
4.2	GROUNDWATER CONDITIONS	7
4.3	SEISMIC DESIGN CONSIDERATIONS.....	7
5.0	ANALYSIS AND RECOMMENDATIONS	8
5.1	RETAINING WALL TYPE EVALUATION.....	8
5.2.1	<i>Bearing Resistance and External Stability Analyses</i>	8
5.2.2	<i>Settlement Analyses</i>	9
5.2.3	<i>Global Stability Analyses</i>	11
5.3	DRILLED SOLDIER PILE WALL	11
5.2.2	<i>Settlement Analyses</i>	14
5.2.3	<i>Global Stability Analyses</i>	15
6.0	CONSTRUCTION CONSIDERATIONS	15
6.1	EXCAVATION	15
6.2	DEWATERING	15
6.3	FILLING AND BACKFILLING.....	15
6.4	WALL CONSTRUCTION	15

6.5	CONSTRUCTION MONITORING.....	15
7.0	QUALIFICATIONS.....	16
	REFERENCES	17
	EXHIBITS	
	1. Site Location Map	
	2. Site and Regional Geology	
	3. Boring Location Plan	
	4. Subsurface Soil Data Profile	
	APPENDIX A	
	Boring Logs and Rock Core Photographs	
	APPENDIX B	
	Laboratory Test Results	
	APPENDIX C	
	Global Stability Analyses	
	APPENDIX D	
	Type Size Location Plan	

LIST OF TABLES

Table 1:	Estimated MSE Wall Long-Term Settlement.....	10
Table 2:	Short-term (Undrained) Geotechnical Parameters for Design of Drilled Soldier Pile Wall.....	12
Table 3:	Long-term (Drained) Geotechnical Parameters for Design of Drilled Shaft Wall	13
Table 4:	Recommended Parameters for Lateral Load Analysis of Drilled Shaft Wall.....	14

**STRUCTURE GEOTECHNICAL REPORT
CIRCLE INTERCHANGE RECONSTRUCTION
RETAINING WALL 14 (PROPOSED SN 016-1803)
F.A.I. ROUTE 94 (I-290 WB TO I-90/94 SB)
IDOT D-91-227-13/PTB 163-001
COOK COUNTY, ILLINOIS
FOR
AECOM**

1.0 INTRODUCTION

This report presents the results of our subsurface investigation, laboratory testing, geotechnical engineering evaluations and recommendations for a new retaining wall, designated as SN 016-1803 (Retaining Wall 14) proposed along the south approach of WS Ramp Bridge (SN 016-1715) in connection with the Circle Interchange Reconstruction project in the City of Chicago, Cook County, Illinois. A *Site Location Map* is presented as Exhibit 1.

The purpose of Wang Engineering, Inc. (Wang) investigation was to characterize the site soil and groundwater conditions, perform geotechnical engineering analyses, and provide recommendations for the design and construction of the new wall structure.

1.1 Project Description

The Circle Interchange is over 50 years old and has significant congestion and safety problems. The project is aiming to improve safety and mobility as well as upgrade the mainline and interchange facilities. The project will also improve other modes of transportation such as transit, pedestrians and bicyclists within the same corridor.

The Circle Interchange Reconstruction project is along Interstate 90/94 (I-90/94) from south of Roosevelt Road to north of Lake Street, along Interstate 290 (I-290) from Loomis Street to the Circle Interchange; and along Congress Parkway from the Circle Interchange to Canal Street/Old Post Office. The routes typically have three lanes of traffic in each direction with mostly one lane ramp at interchanges. Locally, the north leg is known as the Kennedy Expressway, the south leg as the Dan Ryan Expressway and the west leg as the Eisenhower Expressway. Within the project area, there are

several cross street bridges over I-90/94 and I-290 considered for reconstruction. Along I-90/94, from south to north, the cross street overpasses include Taylor Street, Van Buren Street, Jackson Boulevard, and Adams Street. Along I-290, from west to east, the cross street overpasses include Morgan Street, Peoria Street, and Halsted Street.

The proposed improvements include additional through lanes in each direction on I-90/94. The horizontal alignment and vertical profiles throughout the interchange will be improved. A new two-lane flyover, Ramp NW (Flyover) will be constructed for I-90/94 northbound to I-290 westbound traffic. Cross street bridges, Morgan Street, Harrison Street, Halsted Street, Peoria Street, Taylor Street, Adams Street, Jackson Boulevard, and Van Buren Street will be reconstructed. Various existing ramps will be reconstructed and up to fifty new retaining walls will be constructed.

1.2 Proposed Structure

Retaining wall 14 (SN 016-1803) is proposed to support the south approach of the WS Ramp Bridge. Based on the Type, Size, and Location (TSL) plan dated April 10, 2018 provided by TranSystems Corporation, 440.5 feet of walls will be constructed. The walls will consist of two different types, namely, 255.4 feet of Mechanically Stabilized Earth (MSE) wall with 17.4 feet maximum retained height and Lightweight Cellular Concrete Fill (LCCF) backfill, and 185.1 feet of Drilled Soldier Pile wall with 22.8 feet maximum retained height. The TSL plan is included in the *Appendix C*.

1.3 Existing Structure

There is an existing wall 12 footing supported on pile foundations. The wall alignment enters at the proposed left side of proposed wall at an approximate Station 1229+75 on the east and exits at the right side wall at an approximate Station 1231+40 on the west. We understand the existing CIP wall will be removed; however, the foundation will remain in place.

2.0 SITE CONDITIONS AND GEOLOGICAL SETTING

The site is located within the City of Chicago at the I-90/94 and I-290 Circle Interchange. On the USGS *Chicago Loop 7.5 Minute Series* map, the wall is located in the SW $\frac{1}{4}$ of Section 16, Tier 39 N, Range 14 E of the Third Principal Meridian.

The following review of published geologic data, with emphasis on factors that might influence the design and construction of the proposed engineering works, is meant to place the project area within a

geological framework and confirm the dependability and consistency of the present subsurface investigation results. For the study of the regional geologic framework, Wang considered northeastern Illinois in general and Cook County in particular. Exhibit 2 illustrates the *Site and Regional Geology*.

2.1 Physiography

The wall is situated within the Chicago Lake Plain Physiographic Subsection. The area is characterized by a flat surface that slopes gently toward the lake, largely made of groundmoraine till covered by thin and discontinuous lacustrine silt and clay. The ground elevation along the wall ranges from 581 feet at the south end to 591 feet at the north end.

2.2 Surficial Cover

The project area was shaped during the Wisconsin-age glaciation, and more than 75-foot thick drift covers the bedrock (Leetaru et al. 2004). The glacial cover is made up of clay and silt of the Equality Formation of the Mason Group and diamictons of the Wadsworth and Lemont Formations of the Wedron Group (Hansel and Johnson 1996). The Equality Formation is made up of bedded silt and clay, locally laminated, with lenses and/or thin beds of sand and gravel. The Wadsworth Formation consists of relatively homogenous, massive, gray till with clay to silty clay matrix, with dolostone and shale clasts and occasional lenses of sorted and stratified silt. The Wadsworth Formation is underlain by the pebbly silty clay loam to silty loam diamicton of the Yorkville Member of the Lemont Formation, known informally as the Chicago “hardpan.”

From a geotechnical viewpoint, the Equality Formation is characterized by low strength, medium to high plasticity, and medium to high moisture content, whereas the Wadsworth Formation is characterized by low plasticity, medium to low moisture content, medium to very stiff consistency, poor permeability, and low compressibility. The Yorkville Member (hardpan) is characterized by low plasticity, high blow counts, and low moisture content (Bauer et al. 1991; Peck and Reed 1954).

2.3 Bedrock

In the project area, the glacial deposits unconformably rest over approximately 350-foot thick Silurian-age dolostone (Leetaru et al 2004). The top of bedrock may be encountered at 475 to 500 feet elevation or 75 to 100 feet below ground surface (bgs) or more. The Silurian dolostone dips gently eastward at a pace of 15 feet per mile. Only inactive faults are known in the area, and the seismic risk

is minimal (Leetaru et al. 2004; Willman 1971). There are no records of mining activity in the area, but deep tunnel excavations are known to exist.

Our subsurface investigation results fit into the local geologic context. The borings drilled in the project area revealed the native sediments consist of clay to silty clay diamicton of the Wadsworth Formation resting on top of more competent silty clay loam diamicton (hardpan) of the Lemont Formation, which in turn is underlain by bedrock. Sound dolostone bedrock was sampled at a depth of 102 feet bgs, corresponding to 492.4 feet elevation, within the range predicted based on published geological data.

3.0 METHODS OF INVESTIGATION

The following sections outline the subsurface and laboratory investigations. All elevations in this report are based on NAVD 1988.

3.1 Subsurface Investigation

Wang drilled six structure borings, designated as 14-RWB-01 through 14-RWB-03 and 15-RWB-01 through 15-RWB-03 in February to August, 2014. Wang has also referenced three nearby structure borings, designated as 10-RWB-03 through 10-RWB-05 drilled for the Retaining Wall 10 in February to July, 2014. The as-drilled boring locations were surveyed by Dynasty Group, Inc. and station and offset information for each boring were provided by AECOM. Boring location data are presented in the *Boring Logs* (Appendix A). The as-drilled boring locations are shown in the *Boring Location Plan* (Exhibit 3).

ATV- and truck-mounted drilling rigs equipped with hollow stem augers, were used to advance and maintain an open borehole to 10 to 15 feet depths after that mud rotary was used to the boring termination depth. Soil sampling was performed according to AASHTO T 206, "*Penetration Test and Split Barrel Sampling of Soils.*" The soil was sampled at 2.5-foot intervals to 30 feet bgs and at 5-foot intervals to boring termination depths. Soil samples collected from each sampling interval were placed in sealed jars and transported to Wang Geotechnical Laboratory in Lombard, Illinois for further examination and laboratory testing.

Field boring logs, prepared and maintained by a Wang engineer or geologist, include lithological descriptions, visual-manual soil/rock classifications, results of Rimac and pocket penetrometer

unconfined compressive strength tests, results of Standard Penetration Tests (SPT) recorded as blows per 6 inches of penetration. The SPT N value, shown on the soil profile, is the sum of the second and third blows per 6 inches. The soils were described and classified according to Illinois Division of Highways (IDH) Textural Classification system. The field logs were finalized by an experienced engineering geologist after verifying the field visual classifications and laboratory test results.

Groundwater observations were made during drilling to depths of 10 to 15 feet before using rotary wash method. Due to safety considerations, boreholes were backfilled with grout immediately upon completion.

3.2 Vane Shear Tests

Wang performed vane shear tests in Borings VST-01, 1729-VST-01, and 1729-VST-02. Vane shear test was performed using calibrated RocTest vane shear equipment. Tests were performed in undisturbed and remolded conditions. The sensitivity shown on the boring logs is the ratio of shear strength in undisturbed and remolded conditions. In general, the vane shear values for soft clays were significantly higher than the corresponding values from unconfined compressive strength tests using the RIMAC apparatus. Vane shear test results were used for analyses.

3.3 Laboratory Testing

The soil samples were tested in the laboratory for moisture content (AASHTO T265). Atterberg limits (AASHTO T 89/T 90) and particle size analyses (AASHTO T 88) tests were performed on selected soil samples representing the main soil layers encountered during the investigation. Field visual descriptions of the soil samples were verified in the laboratory. Laboratory test results are shown in the *Boring Logs* (Appendix A), in the *Soil Profile* (Exhibit 4), and in the *Laboratory Test Results* (Appendix B).

4.0 RESULTS OF FIELD AND LABORATORY INVESTIGATIONS

Detailed descriptions of the soil conditions encountered during our subsurface investigation are presented in the attached *Boring Logs* (Appendix A) and in the *Soil Profile* (Exhibit 4). Please note that strata contact lines represent approximate boundaries between soil types. The actual transition between soil types in the field may be gradual in horizontal and vertical directions.

4.1 Soil Conditions

Borings drilled on the roadway encountered 12 to 16 inches of concrete overlying 3 to 4 inches of asphalt followed by crushed stone base course. Borings drilled on the grassy area encountered 14 inches of silty loam topsoil. In descending order, the general lithologic succession encountered beneath the pavement structure or topsoil includes: 1) man-made ground (fill); 2) medium stiff to very stiff silty clay to silty loam; 3) very soft to medium stiff clay to silty clay; 4) very stiff to hard silty clay to silty clay loam; 5) hard silty clay loam and dense to very dense silt to silty loam and sand; and 6) strong dolostone.

1) Man-made ground (fill)

Underneath the topsoil or pavement structure, the borings encountered 3 to 9 feet of fill materials. Granular fill consists of loose to dense, gray crushed stone and black to brown silty loam. Cohesive fill includes very stiff, gray silty clay loam. The granular fill layer has N-values of 8 to more than 50 blows per foot and moisture content values of 3 to 57%. The cohesive fill layer has unconfined compressive strength (Q_u) values ranging from 2.1 tsf and moisture content value of 17%.

2) Medium stiff to very stiff silty clay to silty loam

Beneath the fill, at elevations of 579 to 586 feet, the borings encountered 4 to 6 feet of medium stiff to very stiff, brown to gray silty clay to silty loam. This layer has Q_u values ranging from 1.0 to 3.4 tsf and moisture content values between 23 and 29%. This layer is commonly known as the “crust.”

3) Very soft to medium stiff clay to silty clay

At elevations of 573 to 581 feet (8 to 13 feet bgs), the borings revealed up to 40 feet of very soft to medium stiff, gray clay to silty clay with Rimac Q_u values of 0.08 to 1.23 tsf and moisture content values of 20 to 39%. Laboratory index testing on samples from this layer showed liquid limit (L_L) values of 34 to 41% and a plastic limit (P_L) value of 18%. This layer is commonly known as the “Chicago Blue Clay.”

As discussed in Section 3.2, undrained shear strength values from vane shear tests are generally higher than Rimac tests. In-situ undisturbed vane shear strengths obtained in Borings VST-01, 1729-VST-01, and 1729-VST-02 between elevations 575 and 542 feet varied from 580 to 1510 psf.

4) Very stiff to hard silty clay to silty clay loam

At elevations of 540 to 544 feet (37 to 42 feet bgs), the borings encountered up to 10 feet of very stiff to hard silty clay to silty clay loam. The silty clay to silty clay has Q_u values of 3.3 to 7.7 tsf and

moisture content values of 13 to 20%. The borings encountered 2 to 5 feet of medium dense silt to silty loam layers with an N value of 21 blows per foot.

(5) Hard silty clay loam and very dense silt to silty loam and gravelly sand

At elevations of 533 to 541 feet (49 to 59 feet bgs) the borings encountered up to 48 feet of hard silty clay loam to silty loam, dense to very dense silt to silty loam and very dense gravelly sand. This layer has Q_u values of 4.5 to 10.3 tsf, moisture content values of 11 to 27%, and N values of 22 to over 50 blows per foot. Numerous sampler refusal and hard drilling conditions were recorded within this layer.

(6) Strong dolostone

The nearby structure boring, 10-RWB-04 revealed about 4 feet of weathered bedrock on top of strong bedrock. The boring encountered strong bedrock at elevations of 492.4 feet or 102 feet bgs. Based on the 10-foot rock core obtained from Boring 10-RWB-04, the measured RQD value is 71% corresponding fair rock quality. *Bedrock core photograph* is shown in Appendix A.

4.2 Groundwater Conditions

Groundwater was observed during drilling at elevations of 580 to 587 feet (5 to 13 bgs) within the granular fill layer. The groundwater was not observed during drilling or after drilling in borings due to the mud rotary drilling from 10 to 15 feet bgs. The design and construction of the wall should consider the perched water between 580 and 590 feet elevations within the fill layers.

A Piezometer 10-PZ-01 installed near retaining wall 14 was set with in silty loam to sandy loam deposit with the top and bottom of piezometer screen elevations at 519.3 and 499.3 feet (73.0 and 93.0 feet bgs), respectively. The groundwater levels monitored in the piezometer show elevations ranging from 549.2 to 554.5 feet with an average water table elevation of 552.4 feet. Encountering under pressure groundwater bearing layer should be accounted for during design and construction of the wall foundations.

4.3 Seismic Design Considerations

The retaining wall is located in Seismic Performance Zone (SPZ) 1 and is not required to be designed for seismic forces as per 2012 IDOT *Bridge Manual* (IDOT 2012).

5.0 ANALYSIS AND RECOMMENDATIONS

5.1 Retaining Wall Type Evaluation

Based on the TSL plan, the proposed Retaining Wall 14 is mostly fill wall supporting the south approach of the WS Ramp Bridge. A total of 440.5 feet of walls will be constructed. The walls will consist of two different types, namely, 255.4 feet of Mechanically Stabilized Earth (MSE) wall with 17.4 feet maximum retained height, and 185.1 feet of Drilled Soldier Pile wall with 22.8 feet maximum retained height.

The proposed MSE wall is a feasible option for the section from Station 1230+53.48 to Station 1231+81.19 but becomes not feasible for the remaining higher wall sections starting at Station 1229+66.00 because of the need for additional ground improvement to satisfy settlement. The placement of ground improvement is extremely difficult at this section due to the interference of existing wall 12 footing. Therefore, to avoid this and meeting settlement criteria, a drilled soldier pile wall with expanded polystyrene (EPS) blocks was recommended to satisfy the maximum 1-inch settlement criterion for the roadway.

The following sections present the results of our geotechnical engineering analyses and recommendations for the MSE and Drilled Soldier Pile walls' design and construction.

5.2 MSE Wall

The MSE retaining wall base should be established a minimum of 3.5 feet below the finished grade at the front face of the wall for frost protection. There is an existing wall 12 footing supported on pile foundations. The wall alignment enters at the proposed left side of proposed wall at an approximate Station 1229+75 on the east and exits at the right side wall at an approximate Station 1231+40 on the west. We understand the existing CIP wall will be removed; however, the approximately 12-foot wide footing will remain in place.

5.2.1 Bearing Resistance and External Stability Analyses

Based on our boring data, the foundation soils at the MSE wall base elevations includes mostly up to 40 feet of soft to medium stiff clay to silty clay. We estimate, without treatment, the foundation soils will have a nominal bearing resistance of 3,000 psf and a factored bearing resistance of 2,000 psf based on a geotechnical resistance factor of 0.65 (AASHTO 2014).

We analyzed the following options to satisfy the factored bearing resistance available, external stability, and settlement. A reinforcement length equal to 70 percent of the total wall height or a minimum of 8 feet was used.

1. Using regular fill material (unit weight of 125 pcf) for the MSE wall zone and fill area; and
2. Using IDOT District One Class IV Lightweight Cellular Concrete Fill (LCCF) for the MSE wall zone, fill area between the back-to back wall; and

For the Option 1, at the highest portion of the wall near Station 1230+53.48 with a height of 17.4 feet, the wall will apply a maximum factored equivalent bearing pressure of 3,400 psf with a regular MSE wall fill material (unit weight is 125 pcf) which exceeds the factored bearing resistance available.

In Option 2, to reduce the applied wall pressure, we have considered IDOT District One Class IV LCCF with unit weight of 42 pcf for the MSE wall zone as well as fill area in the back-to-back wall between Stations 1230+53.48 and 1231+81.19. There are no lateral forces pushing the wall; therefore, eccentricity is not a concern.

We estimate the wall backfilled with Class IV LCCF will apply a maximum equivalent factored bearing pressure of 1,450 psf, thus the foundation soils will have sufficient bearing resistance to support the wall. We have considered Class IV LCCF for the MSE wall zone and fill area between the back-to-back wall sections.

The estimated friction angle between an MSE wall base and underlying cohesive soil is 30°, and the corresponding friction coefficient is 0.58. MSE retaining walls are designed based on a geotechnical sliding resistance factor of 1.0 for soil-on-soil contact (AASHTO 2014).

5.2.2 Settlement Analyses

We performed settlement analyses using data from Borings 1729-VST-02, 15-RWB-01, and 14-RWB-02 since it is more conservative and closest to maximum height wall sections. We calculated the corresponding long-term settlement of cohesive foundation soils using IDOT *Spreadsheet for Cohesive Soils* dated December 9, 2014. We noted that in calculating the net service pressure for settlement evaluations, the effect of excavation required to the MSE wall base was taken into consideration. The estimated maximum service pressure and long-term settlement at various locations along the wall is shown in Table 1.

Table 1: Estimated MSE Wall Long-Term Settlement

Station Limits	Station	Estimated Maximum Total Height of Wall (feet)	Estimated Maximum Service Pressure w/ Class III LCCF (psf)	Estimated Maximum Long-Term Settlement (inches)
1229+66.00 to 1231+81.19	1229+66.00	26.8	840	1.8
	1230+00.00	23.2	800	1.3
	1230+25.00	20.5	710	1.2
	1230+53.48	17.8	620	1.0
	1231+00.00	12.8	430	0.7

⁽¹⁾ Back-to-back of MSE wall.

Our settlement analyses indicate the wall will undergo about 1.8 inches of long-term settlement from the underlying cohesive soils near Station 1229+66.00 and about 1.0 inches near Station 1230+53.48, thus settlement governs the design. There will be some differential settlement across the proposed wall due to the existing wall footing remain in place and existing grade line. We estimate the soil will achieve 50% of primary consolidation settlement in 19 months and 90% of primary consolidation in 81 months. To reduce settlements to acceptable range of 1-inch for the roadway, we recommend either preloading for 15 months or ground improvement by use of aggregate columns.

If at least 15 months is available after construction of WS ramp embankment and MSE Wall 14 without face panels before pavement placement, then the preloading is a viable option to reach the acceptable settlement for the roadway; however, it is our understanding that the required preloading period of 15 months may not be available due to construction constraints.

MSE wall sections overlapping with Abandoned CIP Concrete wall footings

The overlapping sections of the MSE wall with the abandoned wall footings will require special MSE wall installation and design to ensure that excessive differential settlement between the MSE wall and the rigid existing footings supported on deep foundations are minimized.

5.2.3 Global Stability Analyses

With Class IV LCCF being used as a fill material in reinforced zone and in between the walls and the whole mass will act as rigid body with significant reduction of the driving forces, we do not see global instability concerns for the proposed MSE retaining wall.

5.3 Drilled Soldier Pile Wall

We recommend drilled shafts should be designed for both lateral earth pressure and lateral deformation. The embedment depth in moment equilibrium for the wall section should be designed in accordance with the LRFD guidelines (AASHTO 2017). Generally, overconsolidated clayey soils, such as the stiff to very stiff clays and very dense silty loam will exhibit lower overall shear strength in the long-term condition; however, normally-consolidated clayey soils such as the very soft to medium stiff clay to silty clay (Chicago blue clay) will likely exhibit significantly lower shear strength in the short-term condition. Therefore, the lateral earth pressure analysis should be performed for walls in both the short-term (undrained) and long-term (drained) condition using the soil parameters shown in Tables 2 and 3.

The undrained shear strength properties of the soft to medium stiff silty clay were taken from the vane shear test results shown in Boring VST-06. The earth pressure coefficients were calculated based on horizontal slopes behind and in front of the walls as per cross-section drawings. In addition, the results of unconfined compressive test results and undrained shear strength (cohesion) results from triaxial UU tests for the Circle Interchange project were also considered in the development of soil parameters. Moreover, the drained friction angle parameters of the soft to medium stiff clay layer were estimated from the consolidated-undrained (CU) triaxial tests performed on this stratum within the Circle Interchange project.

The design of the wall should ignore 3 feet of soil in front of the wall measured from the finished ground surface elevation in providing passive pressure due to excavation required for installation of concrete facing, drainage system and frost-heave condition. In developing the design lateral pressure, the lateral pressure due to construction equipment surcharge load should be added to the lateral earth pressure. Drainage behind the wall and underdrain should be as per 2012 IDOT *Bridge Manual* (IDOT 2012). The water pressure should be added to the earth pressure if drainage is not provided.

Table 2: Short-term (Undrained) Geotechnical Parameters for Design of Drilled Soldier Pile Wall (Ref. Borings: 14-RWB-01, 14-RWB-02, 15-RWB-01, 10-RWB-03, 1729-VST-02, and VST-01)

Soil Description (Layer)	Unit Weight, γ (pcf)	Undrained Shear Strength Properties		Earth Pressure Coefficients	
		Cohesion (psf)	Friction Angle ($^{\circ}$)	Active Pressure	Passive Pressure
EPS Blocks Proposed Grade to EL 574 feet	2	0	37	0.00 ⁽²⁾	--
Soft to M Stiff CLAY to SILTY CLAY EL 574 to 556 feet	110	600	0	1.00	1.00
M Stiff CLAY to SILTY CLAY EL 556 to 549 feet	110	750	0	1.00	1.00
M Stiff CLAY to SILTY CLAY EL 549 to 544 feet	115	1050	0	1.00	1.00
Stiff CLAY to SILTY CLAY EL 544 to 540 feet	120	1400	0	1.00	1.00
Hard SILTY CLAY EL 540 to 532 feet	125	5000	0	1.00	1.00
M Dense SAND to SANDY LOAM EL 532 to 515 feet	63 ⁽¹⁾	0	35	0.27	3.69
Hard SILTY CLAY LOAM to SILTY LOAM EL 515 to 506 feet	63 ⁽¹⁾	4500	0	1.00	1.00
V Dense SILTY LOAM EL 506 to 496 feet	63 ⁽¹⁾	0	33	0.29	3.39
V Dense WEATHERED BEDROCK EL 496 to 490 feet	73 ⁽¹⁾	0	37	0.25	4.02

(1) Submerged unit weight.

(2) No lateral load on retaining structures provided the soil excavation back-slope is self supporting repose angle

Table 3: Long-term (Drained) Geotechnical Parameters for Design of Drilled Shaft Wall
 (Ref. Borings: 14-RWB-01, 14-RWB-02, 15-RWB-01, 10-RWB-03, 1729-VST-02, and VST-01)

Soil Description (Layer)	Unit Weight, γ (pcf)	Drained Shear Strength Properties		Earth Pressure Coefficients	
		Cohesion (psf)	Friction Angle ($^{\circ}$)	Active Pressure	Passive Pressure
EPS Blocks Proposed Grade to EL 574 feet	2	0	30	0.00 ⁽²⁾	--
Soft to M Stiff CLAY to SILTY CLAY EL 574 to 556 feet	110	0	27	0.38	2.66
M Stiff CLAY to SILTY CLAY EL 556 to 549 feet	110	0	27	0.38	2.66
M Stiff CLAY to SILTY CLAY EL 549 to 544 feet	115	0	27	0.38	2.66
Stiff CLAY to SILTY CLAY EL 544 to 540 feet	120	100	29	0.35	2.88
Hard SILTY CLAY EL 540 to 532 feet	125	100	30	0.33	3.00
M Dense SAND to SANDY LOAM EL 532 to 515 feet	63 ⁽¹⁾	0	35	0.27	3.69
Hard SILTY CLAY LOAM to SILTY LOAM EL 515 to 506 feet	63 ⁽¹⁾	100	30	0.33	3.00
V Dense SILTY LOAM EL 506 to 496 feet	63 ⁽¹⁾	0	33	0.29	3.39
V Dense WEATHERED BEDROCK EL 496 to 490 feet	73 ⁽¹⁾	0	37	0.25	4.02

(1) Submerged unit weight.

(2) No lateral load on retaining structures provided the soil excavation back-slope is self supporting repose angle

Design considerations should include deflection control at the top of the wall. The lateral deformation of the wall should be designed using the parameters shown in Table 3 using the p-y curve (COMP624) method.

Table 4: Recommended Parameters for Lateral Load Analysis of Drilled Shaft Wall
(Ref. Borings: 14-RWB-01, 14-RWB-02, 15-RWB-01, 10-RWB-03, 1729-VST-02, and VST-01)

Soil Type (Layer)	Unit Weight, γ (pcf)	Undrained Shear Strength, c_u (psf)	Estimated Friction Angle, Φ ($^\circ$)	Estimated Lateral Soil Modulus Parameter, k (pci)	Estimated Soil Strain Parameter, ϵ_{50} (%)
EPS Blocks Proposed Grade to EL 574 feet	2	0	37	30	--
Soft to M Stiff CLAY to SILTY CLAY EL 574 to 556 feet	110	600	0	60	1.0
M Stiff CLAY to SILTY CLAY EL 556 to 549 feet	110	750	0	80	1.0
M Stiff CLAY to SILTY CLAY EL 549 to 544 feet	115	1050	0	100	1.0
Stiff CLAY to SILTY CLAY EL 544 to 540 feet	120	1400	0	500	0.7
Hard SILTY CLAY EL 540 to 532 feet	125	5000	0	2000	0.4
M Dense to Dense SAND to SANDY LOAM EL 532 to 515 feet	63 ⁽¹⁾	0	35	90	--
Hard SILTY CLAY LOAM to SILTY LOAM EL 515 to 506 feet	63 ⁽¹⁾	4500	0	2000	0.4
V Dense SILTY LOAM EL 506 to 496 feet	63 ⁽¹⁾	0	33	120	--
V Dense WEATHERED BEDROCK EL 496 to 490 feet	73 ⁽¹⁾	0	37	125	--

(1) Submerged unit weight.

5.2.2 Settlement Analyses

Since the backfill between the drilled soldier pile walls forming the ramp will be EPS blocks with very low unit weight (about 2 pcf), the applied foundation pressure will be low, thus we do not anticipate any settlement concerns.

5.2.3 Global Stability Analyses

With EPS blocks used as a fill material in between the drilled soldier pile walls, the driving forces are low, thus we do not anticipate global instability concerns for the proposed retaining wall.

6.0 CONSTRUCTION CONSIDERATIONS

6.1 Excavation

Any required excavations should be performed in accordance with local, state, and federal regulations including current OSHA regulations. The potential effect of ground movements upon nearby structures and utilities should be considered during construction. Any open excavation to a depth of 4 feet should have a slope of 1:2 (V:H) for cohesive soils and 1:2.5 (V:H) for granular soils or flatter.

6.2 Dewatering

Based on the results of our investigation and proposed excavation for the wall, perched water is likely to be encountered during construction during times of heavy precipitation which should be removed through conventional sump and pump methods.

6.3 Filling and Backfilling

All fill and backfill materials will be as per IDOT *Standard Specification for Road and Bridge Construction* (IDOT 2016).

6.4 Wall Construction

The wall should be constructed as per IDOT *Standard Specification for Road and Bridge Construction* (IDOT 2016) and IDOT special provisions for *Mechanically Stabilized Earth Retaining Walls* (IDOT 2015). Class IV LCCF should be as per IDOT District One special provision.

6.5 Construction Monitoring

There is no need for special construction monitoring for the retaining wall except normally required by the IDOT *Standard Specification for Road and Bridge Construction* (IDOT 2016). However, given the proximity of structure, roads, and utilities, special precautions should be taken during the construction to not to undermine the existing foundations, pavements and utilities.

7.0 QUALIFICATIONS

The analysis and recommendations submitted in this report are based upon the data obtained from the borings drilled at the locations shown on the boring logs and in Exhibit 3. This report does not reflect any variations that may occur between the borings or elsewhere on the site, variations whose nature and extent may not become evident until the course of construction. In the event that any changes in the design and/or location of Retaining Wall 14 (SN016-1803) are planned, we should be timely informed so that our recommendations can be adjusted accordingly.

It has been a pleasure to assist AECOM and the Illinois Department of Transportation on this project. Please call if there are any questions, or if we can be of further service.

Respectfully Submitted,

WANG ENGINEERING, INC.

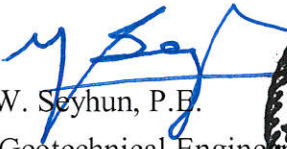
Metin W. Seyhun, P.E.
Senior Geotechnical Engineer

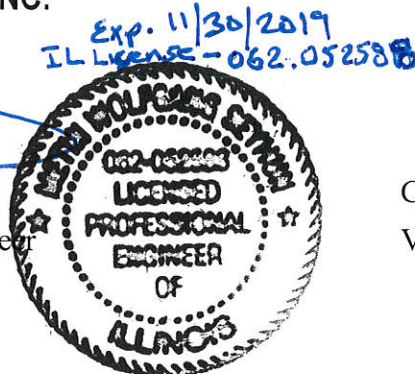

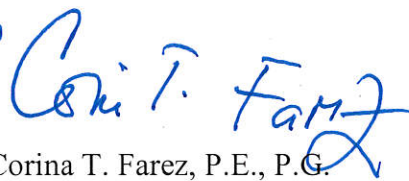

Corina T. Farez, P.E., P.G.
Vice President

Nesam S. Balakumaran
Project Geotechnical Engineer

REFERENCES

- AMERICAN ASSOCIATION OF STATE HIGHWAY TRANSPORTATION OFFICIALS (2014) *LRFD Bridge Design Specifications*. United States Department of Transportation, Washington, D.C.
- BAUER, R.A., CURRY, B.B., GRAESE, A.M., VAIDEN, R.C., SU, W.J., and HASEK, M.J., 1991, *Geotechnical Properties of Selected Pleistocene, Silurian, and Ordovician Deposits of Northeastern Illinois*: Environmental Geology 139, Illinois State Geological Survey, 69 p.
- HANSEL, A.K., and JOHNSON, W.H. (1996) *Wedron and Mason Groups: Lithostratigraphic Reclassification of the Wisconsin Episode, Lake Michigan Lobe Area: ISGS Bulletin 104*. Illinois State Geological Survey, Champaign, IL. 116 p.
- LEETARU, H.E., SARGENT, M.L., AND KOLATA, D.R., 2004, *Geologic Atlas of Cook County for Planning Purposes*, ISGS, Champaign, IL
- ILLINOIS DEPARTMENT OF TRANSPORTATION (2015) *Geotechnical Manual*. IDOT Bureau of Materials and Physical Research, Springfield, IL.
- ILLINOIS DEPARTMENT OF TRANSPORTATION (2016) *Standard Specifications for Road and Bridge Construction*. IDOT Division of Highways, Springfield, IL.
- ILLINOIS DEPARTMENT OF TRANSPORTATION (2012) *Bridge Manual*. IDOT Bureau of Bridges and Structures, Springfield, IL.
- WILLMAN, H.B., 1971, *Summary of the Geology of the Chicago Area*, ISGS Circular C460: Urbana, Illinois State Geological Survey, p. 77.
- PECK, R.B., and REED, W.C., 1954, *Engineering Properties of Chicago Subsoils*: University of Illinois Engineering Experiment Station Bulletin No. 423: Urbana, University of Illinois, 62 p.
- FEDERAL HIGHWAY ADMINISTRATION (1983) *Design and Construction of Stone Columns Vol 1*. US Department of Transportation Report No. FHWA/RD-83/026, McLean, Virginia.

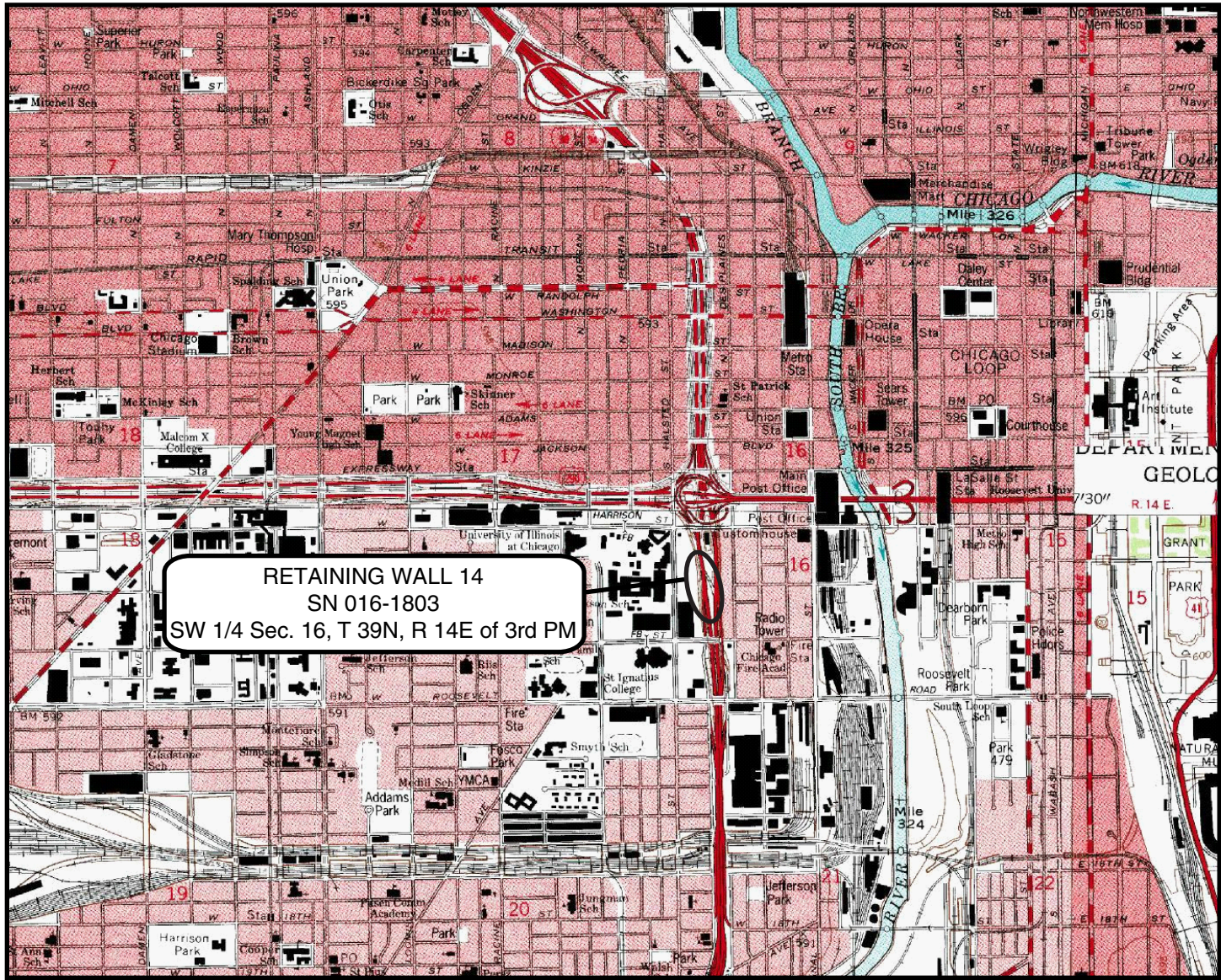
EXHIBITS



RETAINING WALL 14
 SN 016-1803
 SW 1/4 Sec. 16, T 39N, R 14E of 3rd PM

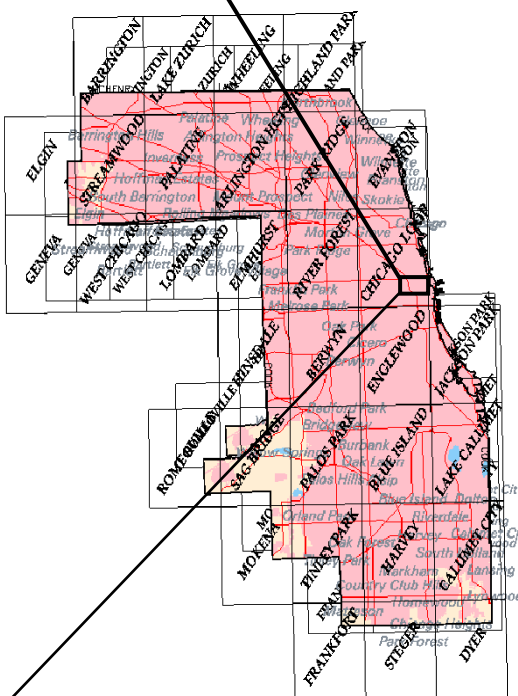
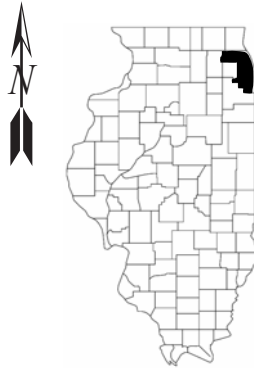

Cook County

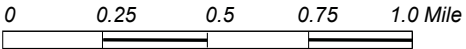

SITE LOCATION MAP: CIRCLE INTERCHANGE RECONSTRUCTION, RETAINING WALL 14, SN 016-1803, COOK COUNTY		
SCALE: GRAPHICAL	EXHIBIT 1	DRAWN BY: H. Bista CHECKED BY: M. Seyhun
		1145 N. Main Street Lombard, IL 60148 www.wangeng.com
FOR AECOM		1100-04-01

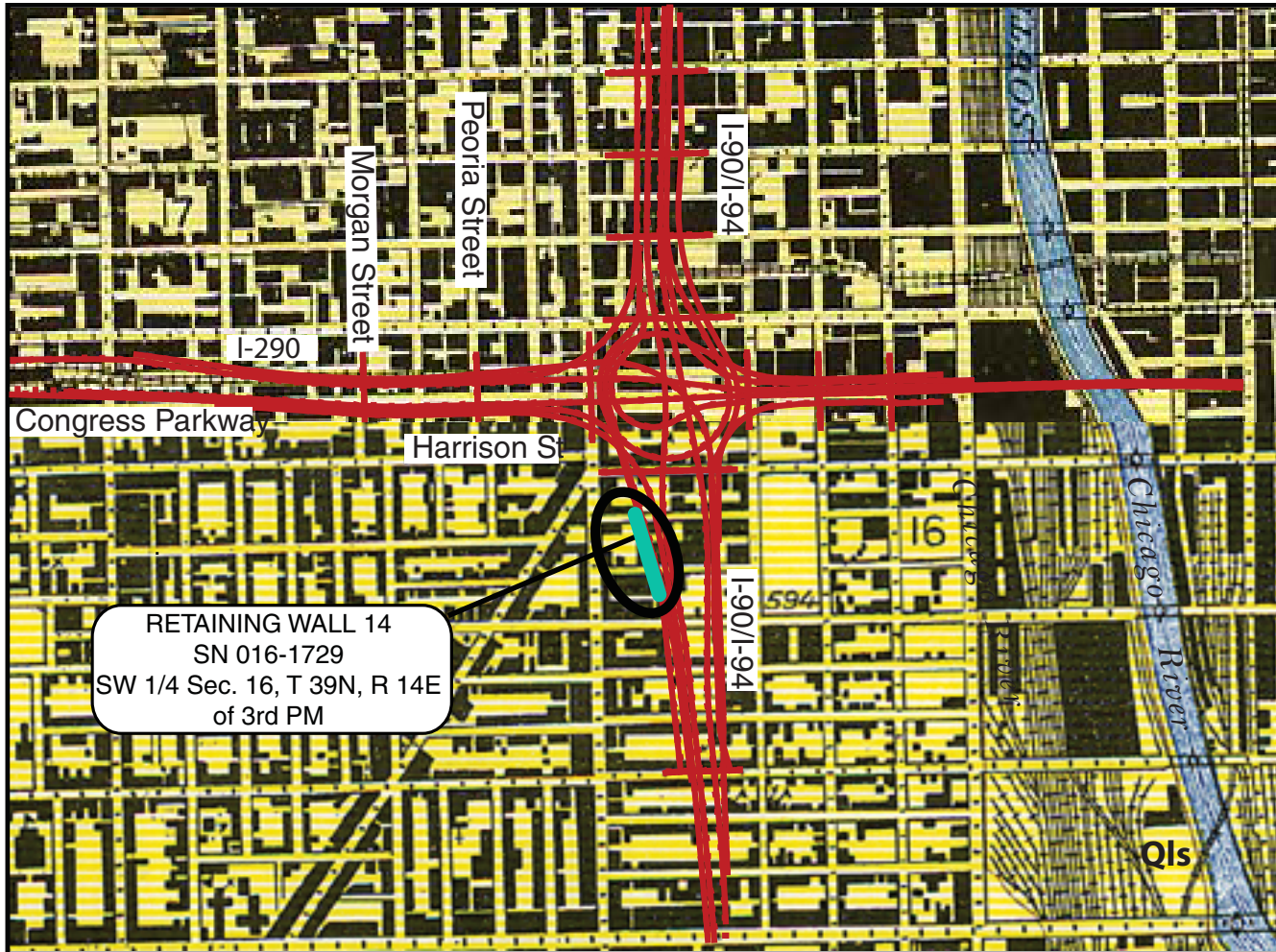

Modified after Bretz (1926)



REGIONAL GEOLOGY

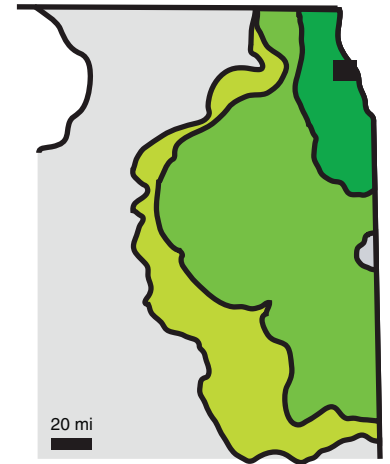

Wedron Group

- Wadsworth Formation
- Lemont Formation
- Tiskilwa Formation

Modified after Hansel and Johnson (1996)

Legend

- Qls
Glacial lake bottom
(Covered by lacustrine deposits)

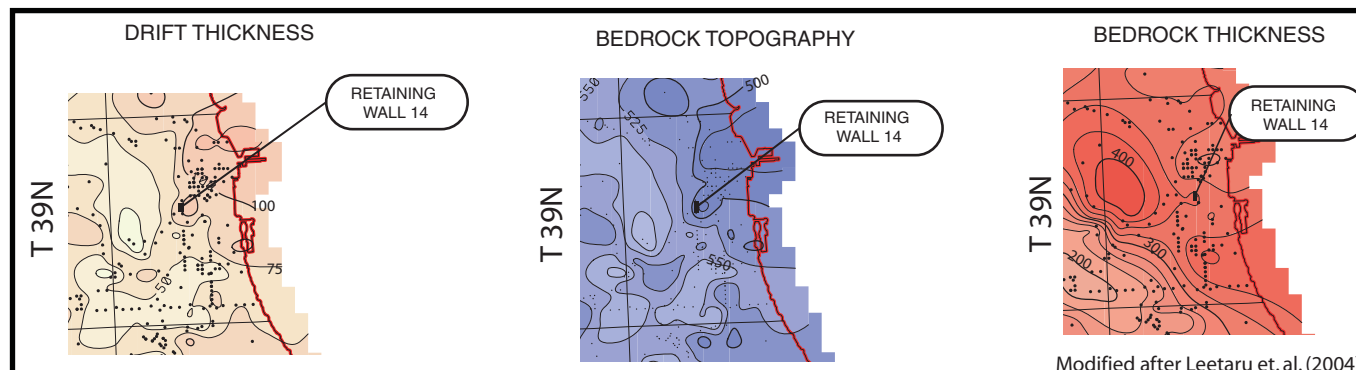

Modified after Leetaru et. al. (2004)

0 2 4 8 miles

SITE AND REGIONAL GEOLOGY: CIRCLE INTERCHANGE
RECONSTRUCTION, RETAINING WALL 14, SN 016-1803, COOK COUNTY

SCALE: GRAPHICAL

EXHIBIT 2

DRAWN BY: H. Bista
CHECKED BY: M. Seyhun



1145 N. Main Street
Lombard, IL 60148
www.wangeng.com

Bench Mark: Chisel "X" on chain bolt of fire hydrant in front of 555 W. Harrison St. Elev. 594.46.

Existing Structure: None.

The existing Ramp WS Bridge (S.N. 016-1715) will be closed and traffic will be detoured during construction. Traffic on I-290 and I-90/94 will be maintained with stage construction.

No Salvage.

NOTES:

1. Wall offsets are measured from the C of Ramp WS to the front face of panels.
2. F.F. denotes Front Face.
3. B.F. denotes Back Face.
4. All proposed drainage structure locations along I-90/94 are conceptual at this stage and are subject to refinement during final design.
5. Soldier Pile section, shaft diameter, spacing and tip elevation to be determined during final design.

DESIGN SPECIFICATIONS

2014 AASHTO LRFD Bridge Design Specifications 7th Edition with 2015 and 2016 Interim Specifications

DESIGN STRESSES

FIELD UNITS
 $f'_c = 3,500 \text{ psi}$
 $f_y = 60,000 \text{ psi (Reinforcement)}$

PRECAST UNITS

$f'_c = 4,500 \text{ psi}$

SOLDIER PILES

$f_y = 50,000 \text{ psi (AASHTO M270 Gr. 50)}$

WALL DEFLECTION CRITERIA:

Maximum total lateral wall deflection at top of wall: 1 inch.

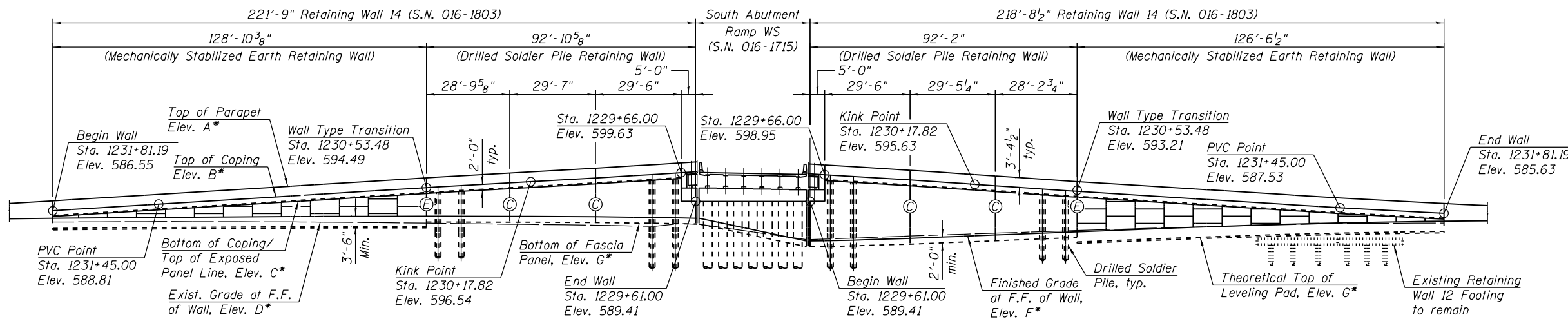

* For elevations, see Table 1 on sheet 2 of 3.

ELEVATION
 (Looking at F.F. of Wall, Proposed Concrete Barrier Not Shown for Clarity)

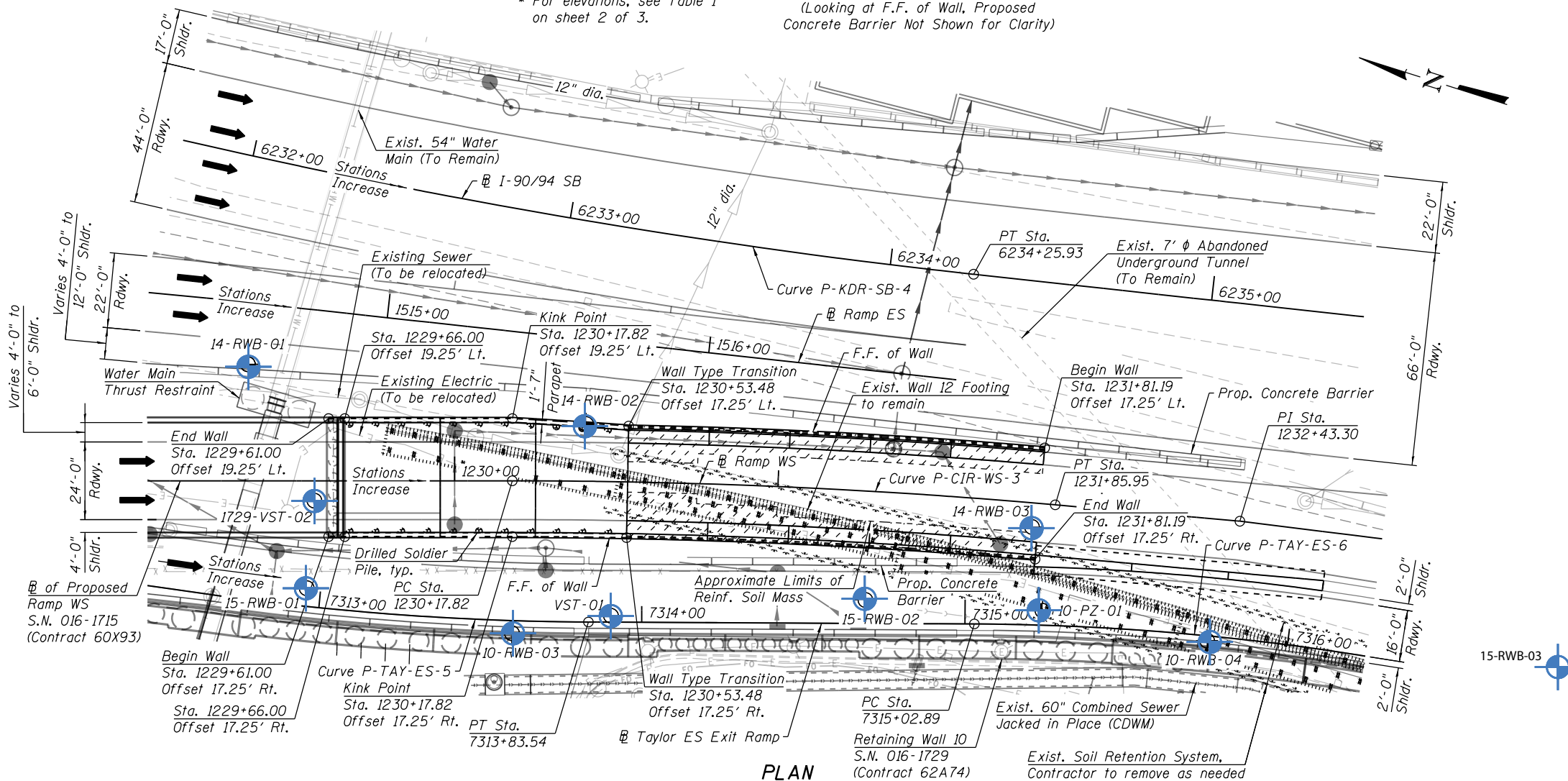

PLAN

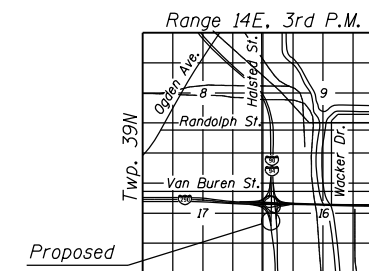

LOCATION SKETCH

GENERAL PLAN
RETAINING WALL 14 ALONG RAMP WS
F.A.I 94 (I-290 WB TO I-90/94 SB)
SECTION 2014-013 R&B-R
COOK COUNTY
STATION 1229+61.00 TO STATION 1231+81.19
STRUCTURE NO. 016-1803

BORING LOCATION PLAN: CIRCLE INTERCHANGE RECONSTRUCTION RETAINING WALL 14, SN 016-1803, COOK COUNTY			
SCALE: GRAPHICAL	EXHIBIT 3	DRAWN BY: NSB	CHECKED BY: MWS
		1145 N. Main Street Lombard, IL 60148 www.wangeng.com	
FOR AECOM			1100-04-01



USER NAME = jrmickens	DESIGNED - JM	REVISED -
PLOT SCALE = 42.666667' / in.	CHECKED - WJC	REVISED -
PLOT DATE = 4/10/2018	DRAWN - JM	REVISED -
	CHECKED - WJC	REVISED -

STATE OF ILLINOIS
DEPARTMENT OF TRANSPORTATION

SHEET NO. 1 OF 3 SHEETS

F.A.I. RTE.	SECTION	COUNTY	TOTAL SHEETS	SHEET NO.
90/94/290	2014-013 R&B-R	COOK	3	1
CONTRACT NO. 60X93			ILLINOIS FED. AID PROJECT	

2:16:04 PM PW \\617479-PWINT-AECOM\LINE-LOCAL-AECOM\DS02_NA\DOCUMENTS\NOI_AMERICAS\TRANSPORTATION\60269938_CIRCLE_INTERCHANGE_RECONSTRUCTION\016-1803-TSLS\SHEETS\016-1803-60X93-SHT-TSL-001

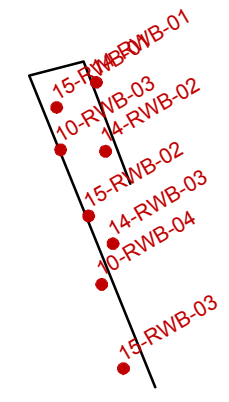
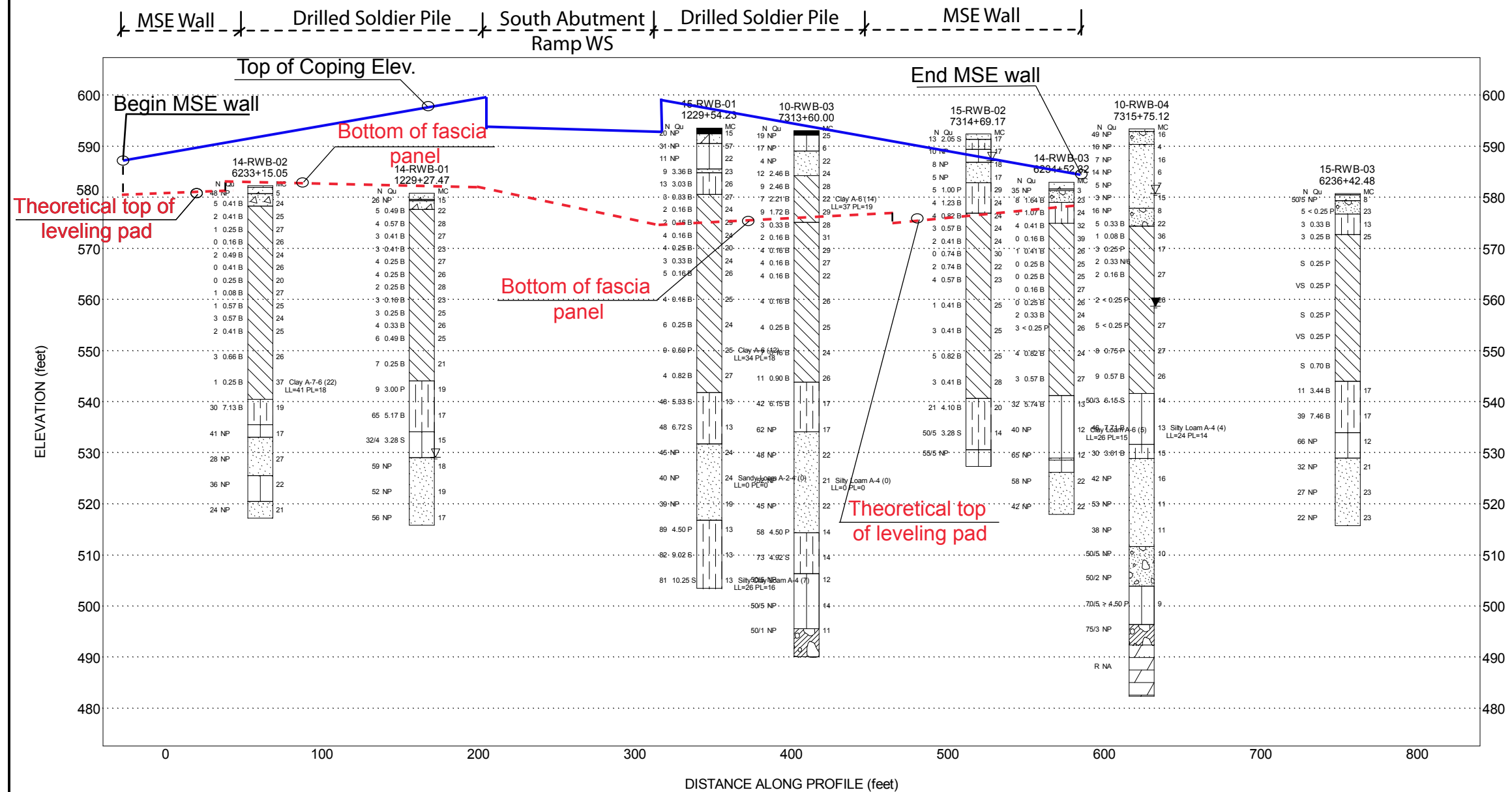

Site Map Scale 1 inch equals 295 feet

Explanation:

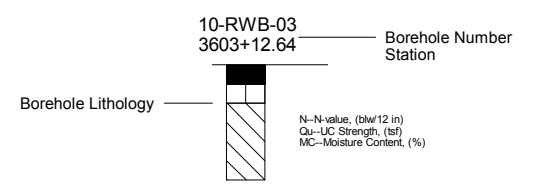

- ▽ Water Level Reading at time of drilling.
- ▼ Water Level Reading 24-hr after drilling or at end of drilling

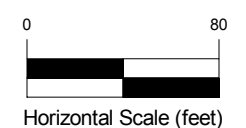

Vertical Exaggeration: 3.5x

Wang Engineering, Inc.
1145 N Main Street
Lombard, IL 60148

**Subsurface Soil Data Profile
Retaining Wall 14; SN 016-1803**



Circle Interchange Reconstruction
Section 17, T39N, R14E of 3rd PM

JOB NUMBER	PLATE NUMBER
1100-04-01	EXHIBIT 4

Lithology Graphics

- | | | | |
|---------------------------------|----------------------|----------------------|-----------------------------|
| Topsoil | IDH Silt, Silty Loam | IDH Sand, Sandy Loam | IDH Clay |
| IDH Silty Clay, Silty Clay Loam | Weathered bedrock | Pavement | Gravelly sand, sandy gravel |
| Dolomite or Dolomitic Limestone | Concrete | Crushed stone | IDH Loam |

WEI 11X17 11000401.GPJ_WANGENG.GDT 8/15/17

APPENDIX A



wangeng@wangeng.com
 1145 N Main Street
 Lombard, IL 60148
 Telephone: 630 953-9928
 Fax: 630 953-9938

BORING LOG 14-RWB-01

WEI Job No.: 1100-04-01

Client: **AECOM**
 Project: **Circle Interchange Reconstruction**
 Location: **Section 17, T39N, R14E of 3rd PM**

Datum: NAVD 88
 Elevation: 580.85 ft
 North: 1897238.90 ft
 East: 1171475.76 ft
 Station: 1229+27.47
 Offset: 39.6372 LT

Profile	Elevation (ft)	SOIL AND ROCK DESCRIPTION	Depth (ft)	Sample Type recovery	Sample No.	SPT Values (blw/6 in)	Qu (tsf)	Moisture Content (%)	Profile	Elevation (ft)	SOIL AND ROCK DESCRIPTION	Depth (ft)	Sample Type recovery	Sample No.	SPT Values (blw/6 in)	Qu (tsf)	Moisture Content (%)
		15-inch thick CONCRETE --PAVEMENT--															
	579.6																
	579.3	3-inch thick ASPHALT															
		Medium dense, brownish white CRUSHED STONE --BASE COURSE--			1	15 17 9	NP	15						9	1 2 1	0.16 B	23
	577.6				2	3 2 3	0.49 B	22				25		10	1 2 1	0.25 B	25
		Soft, gray CLAY to SILTY CLAY, trace gravel			3	1 2 2	0.57 B	28						11	0 2 2	0.33 B	26
					4	1 2 1	0.41 B	27				30		12	2 3 3	0.49 B	25
					5	2 1 2	0.41 B	23									
					6	2 2 2	0.25 B	27				35		13	2 3 4	0.25 B	21
					7	2 1 3	0.25 B	26		544.1	Very stiff to hard, gray SILTY CLAY, trace gravel						
					8	1 1 1	0.25 B	28				40		14	3 4 5	3.00 P	19

GENERAL NOTES

Begin Drilling **07-28-2014** Complete Drilling **07-29-2014**
 Drilling Contractor **Wang Testing Services** Drill Rig **CME-55 TMR [85%]**
 Driller **R&J** Logger **A. Happel** Checked by **C. Marin**
 Drilling Method **2.25" HSA to 10', mud rotary thereafter, boring**
backfilled upon completion

WATER LEVEL DATA

While Drilling **Rotary wash**
 At Completion of Drilling **mud in the borehole**
 Time After Drilling **NA**
 Depth to Water **NA**

The stratification lines represent the approximate boundary between soil types; the actual transition may be gradual.

WANGENGINC 11000401.GPJ WANGENG.GDT 8/25/17



BORING LOG 14-RWB-01

wangeng@wangeng.com
 1145 N Main Street
 Lombard, IL 60148
 Telephone: 630 953-9928
 Fax: 630 953-9938

WEI Job No.: 1100-04-01

Client: **AECOM**
 Project: **Circle Interchange Reconstruction**
 Location: **Section 17, T39N, R14E of 3rd PM**

Datum: NAVD 88
 Elevation: 580.85 ft
 North: 1897238.90 ft
 East: 1171475.76 ft
 Station: 1229+27.47
 Offset: 39.6372 LT

Profile	Elevation (ft)	SOIL AND ROCK DESCRIPTION	Depth (ft)	Sample Type recovery	Sample No.	SPT Values (blw/6 in)	Qu (tsf)	Moisture Content (%)	Profile	Elevation (ft)	SOIL AND ROCK DESCRIPTION	Depth (ft)	Sample Type recovery	Sample No.	SPT Values (blw/6 in)	Qu (tsf)	Moisture Content (%)
	534.1	Very stiff, gray SILTY LOAM to SILTY CLAY LOAM, trace gravel	45	X	15	12 18 47	5.17 B	17		515.8		65	X	19	14 23 33	NP	17
											Boring terminated at 65.00 ft						
	529.1	Very dense, gray SAND to SANDY LOAM, trace gravel	50	X	16	33 45 32 1/4	3.28 S	15				70					
			55	X	17	17 23 36	NP	18				75					
			60	X	18	13 30 22	NP	19				80					

GENERAL NOTES

Begin Drilling **07-28-2014** Complete Drilling **07-29-2014**
 Drilling Contractor **Wang Testing Services** Drill Rig **CME-55 TMR [85%]**
 Driller **R&J** Logger **A. Happel** Checked by **C. Marin**
 Drilling Method **2.25" HSA to 10', mud rotary thereafter, boring backfilled upon completion**

WATER LEVEL DATA

While Drilling **Rotary wash**
 At Completion of Drilling **mud in the borehole**
 Time After Drilling **NA**
 Depth to Water **NA**

The stratification lines represent the approximate boundary between soil types; the actual transition may be gradual.

WANGENGINC 11000401.GPJ WANGENG.GDT 8/25/17



BORING LOG 14-RWB-02

wangeng@wangeng.com
 1145 N Main Street
 Lombard, IL 60148
 Telephone: 630 953-9928
 Fax: 630 953-9938

WEI Job No.: 1100-04-01

Client: **AECOM**
 Project: **Circle Interchange Reconstruction**
 Location: **Section 17, T39N, R14E of 3rd PM**

Datum: NAVD 88
 Elevation: 582.26 ft
 North: 1897133.58 ft
 East: 1171489.78 ft
 Station: 6233+15.05
 Offset: 62.0541 RT

Profile	Elevation (ft)	SOIL AND ROCK DESCRIPTION	Depth (ft)	Sample Type recovery	Sample No.	SPT Values (blw/6 in)	Qu (tsf)	Moisture Content (%)	Profile	Elevation (ft)	SOIL AND ROCK DESCRIPTION	Depth (ft)	Sample Type recovery	Sample No.	SPT Values (blw/6 in)	Qu (tsf)	Moisture Content (%)
	581.94	14-inch thick, ASPHALT --PAVEMENT--															
	580.8	14-inch thick, CONCRETE --PAVEMENT--															
		Dense, grayish white CRUSHED STONE --FILL--			1	37 30 18	NP	5						9	0 0 1	0.08 B	27
	578.3	Soft to medium stiff, gray CLAY to SILTY CLAY, trace gravel			2	1 2 3	0.41 B	24				25		10	0 0 1	0.57 B	25
					3	0 1 1	0.41 B	25						11	0 1 2	0.57 B	24
					4	0 0 1	0.25 B	27				30		12	0 0 2	0.41 B	25
					5	0 0 0	0.16 B	26									
					6	0 0 2	0.49 B	24				35		13	0 1 2	0.66 B	26
					7	0 0 0	0.41 B	26									
					8	0 0 0	0.25 B	20				40		14	0 0 1	0.25 B	37

GENERAL NOTES

WATER LEVEL DATA

Begin Drilling **07-30-2014** Complete Drilling **07-30-2014**
 Drilling Contractor **Wang Testing Services** Drill Rig **D-50 TMR [78%]**
 Driller **R&J** Logger **S. Woods** Checked by **C. Marin**
 Drilling Method **2.25" SSA to 10', mud rotary thereafter, boring backfilled upon completion**

While Drilling ∇ **52.00 ft**
 At Completion of Drilling ∇ **mud in the borehole**
 Time After Drilling **NA**
 Depth to Water ∇ **NA**

The stratification lines represent the approximate boundary between soil types; the actual transition may be gradual.

WANGENGINC 11000401.GPJ WANGENG.GDT 8/25/17



wangeng@wangeng.com
 1145 N Main Street
 Lombard, IL 60148
 Telephone: 630 953-9928
 Fax: 630 953-9938

BORING LOG 14-RWB-02

WEI Job No.: 1100-04-01

Client: **AECOM**
 Project: **Circle Interchange Reconstruction**
 Location: **Section 17, T39N, R14E of 3rd PM**

Datum: NAVD 88
 Elevation: 582.26 ft
 North: 1897133.58 ft
 East: 1171489.78 ft
 Station: 6233+15.05
 Offset: 62.0541 RT

Profile	Elevation (ft)	SOIL AND ROCK DESCRIPTION	Depth (ft)	Sample Type recovery	Sample No.	SPT Values (blw/6 in)	Qu (tsf)	Moisture Content (%)	Profile	Elevation (ft)	SOIL AND ROCK DESCRIPTION	Depth (ft)	Sample Type recovery	Sample No.	SPT Values (blw/6 in)	Qu (tsf)	Moisture Content (%)
	540.5	Hard, gray SILTY CLAY, trace gravel	45	X	15	6 11 19	7.13 B	19		520.5	Medium dense, brown fine SAND --Moist--	65	X	19	9 11 13	NP	21
	535.5	Gray SILTY LOAM, trace gravel															
	533.1	Medium dense, brown, fine SAND --Moist--	50	X	16	14 23 18	NP	17			Boring terminated at 65.00 ft						
	525.5	Dense, gray SILT --Moist--	60	X	18	11 17 19	NP	22									

GENERAL NOTES

Begin Drilling **07-30-2014** Complete Drilling **07-30-2014**
 Drilling Contractor **Wang Testing Services** Drill Rig **D-50 TMR [78%]**
 Driller **R&J** Logger **S. Woods** Checked by **C. Marin**
 Drilling Method **2.25" SSA to 10', mud rotary thereafter, boring backfilled upon completion**

WATER LEVEL DATA

While Drilling ∇ **52.00 ft**
 At Completion of Drilling ∇ **mud in the borehole**
 Time After Drilling **NA**
 Depth to Water ∇ **NA**

The stratification lines represent the approximate boundary between soil types; the actual transition may be gradual.

WANGENGINC 11000401.GPJ WANGENG.GDT 8/25/17



wangeng@wangeng.com
 1145 N Main Street
 Lombard, IL 60148
 Telephone: 630 953-9928
 Fax: 630 953-9938

BORING LOG 14-RWB-03

WEI Job No.: 1100-04-01

Client: **AECOM**
 Project: **Circle Interchange Reconstruction**
 Location: **Section 17, T39N, R14E of 3rd PM**

Datum: NAVD 88
 Elevation: 582.96 ft
 North: 1896992.53 ft
 East: 1171501.15 ft
 Station: 6234+52.32
 Offset: 75.7462 RT

Profile	Elevation (ft)	SOIL AND ROCK DESCRIPTION	Depth (ft)	Sample Type recovery	Sample No.	SPT Values (blw/6 in)	Qu (tsf)	Moisture Content (%)	Profile	Elevation (ft)	SOIL AND ROCK DESCRIPTION	Depth (ft)	Sample Type recovery	Sample No.	SPT Values (blw/6 in)	Qu (tsf)	Moisture Content (%)
		16-inch thick CONCRETE --PAVEMENT--															
	581.6																
	581.34	1/2-inch thick ASPHALT --PAVEMENT--															
		Dense, grayish white SANDY GRAVEL --FILL--		X	1	22 22 13	NP	3					X	9	0 0 0	0.16 B	27
	579.0			X	2	4 3 5	1.64 B	23					X	10	0 0 0	0.25 B	26
		Stiff, gray SILTY CLAY, trace gravel		X	3	2 2 3	1.07 B	24					X	11	0 1 1	0.33 B	24
	575.0			X	4	1 2 2	0.41 B	32					X	12	1 1 2	< 0.25 P	26
		Very soft to medium stiff, gray CLAY to SILTY CLAY, trace gravel		X	5	0 0 0	0.16 B	39					X	13	1 2 2	0.82 B	24
				X	6	0 0 1	0.41 B	26					X	14	1 1 2	0.57 B	27
				X	7	0 0 0	0.25 B	25					X	14	1 1 2	0.57 B	27
				X	8	0 0 0	0.25 B	25					X	14	1 1 2	0.57 B	27

GENERAL NOTES

Begin Drilling **07-20-2014** Complete Drilling **07-20-2014**
 Drilling Contractor **Wang Testing Services** Drill Rig **D-50 TMR [78%]**
 Driller **R&J** Logger **S. Woods** Checked by **C. Marin**
 Drilling Method **2.25" SSA to 10', mud rotary thereafter, boring backfilled upon completion**

WATER LEVEL DATA

While Drilling ∇ **57.00 ft**
 At Completion of Drilling ∇ **mud in the borehole**
 Time After Drilling **NA**
 Depth to Water ∇ **NA**

The stratification lines represent the approximate boundary between soil types; the actual transition may be gradual.

WANGENGINC 11000401.GPJ WANGENG.GDT 8/25/17



BORING LOG 14-RWB-03

wangeng@wangeng.com
 1145 N Main Street
 Lombard, IL 60148
 Telephone: 630 953-9928
 Fax: 630 953-9938

WEI Job No.: 1100-04-01

Client: **AECOM**
 Project: **Circle Interchange Reconstruction**
 Location: **Section 17, T39N, R14E of 3rd PM**

Datum: NAVD 88
 Elevation: 582.96 ft
 North: 1896992.53 ft
 East: 1171501.15 ft
 Station: 6234+52.32
 Offset: 75.7462 RT

Profile	Elevation (ft)	SOIL AND ROCK DESCRIPTION	Depth (ft)	Sample Type recovery	Sample No.	SPT Values (blw/6 in)	Qu (tsf)	Moisture Content (%)	Profile	Elevation (ft)	SOIL AND ROCK DESCRIPTION	Depth (ft)	Sample Type recovery	Sample No.	SPT Values (blw/6 in)	Qu (tsf)	Moisture Content (%)
	541.2	Dense to very dense, gray CLAY LOAM to SILTY LOAM, trace gravel															
		--Dry--	45	X	15	8 12 20	5.74 B	13		518.0		65	X	19	16 20 22	NP	22
											Boring terminated at 65.00 ft						
		--L _L (%)=26, P _L (%)=15-- --%Gravel=5.1-- --%Sand=25.2-- --%Silt=47.0-- --%Clay=22.7-- --A-6 (5)--	50	X	16	13 20 20	NP	12				70					
	528.5	--5-inch, brown, coarse SAND--	55	X	17	9 18 47	NP	12				75					
	526.2	Dense to very dense, brown, fine SAND															
		--Moist--	60	X	18	15 21 37	NP	22				80					

GENERAL NOTES

WATER LEVEL DATA

Begin Drilling **07-20-2014** Complete Drilling **07-20-2014**
 Drilling Contractor **Wang Testing Services** Drill Rig **D-50 TMR [78%]**
 Driller **R&J** Logger **S. Woods** Checked by **C. Marin**
 Drilling Method **2.25" SSA to 10', mud rotary thereafter, boring backfilled upon completion**

While Drilling ∇ **57.00 ft**
 At Completion of Drilling ∇ **mud in the borehole**
 Time After Drilling **NA**
 Depth to Water ∇ **NA**

The stratification lines represent the approximate boundary between soil types; the actual transition may be gradual.

WANGENGINC 11000401.GPJ WANGENG.GDT 8/25/17



wangeng@wangeng.com
 1145 N Main Street
 Lombard, IL 60148
 Telephone: 630 953-9928
 Fax: 630 953-9938

BORING LOG 15-RWB-01

WEI Job No.: 1100-04-01

Client: **AECOM**
 Project: **Circle Interchange Reconstruction**
 Location: **Section 17, T39N, R14E of 3rd PM**

Datum: NAVD 88
 Elevation: 593.54 ft
 North: 1897200.61 ft
 East: 1171415.26 ft
 Station: 1229+54.23
 Offset: 33.2105 RT

Profile	Elevation (ft)	SOIL AND ROCK DESCRIPTION	Depth (ft)	Sample Type recovery	Sample No.	SPT Values (blw/6 in)	Qu (tsf)	Moisture Content (%)	Profile	Elevation (ft)	SOIL AND ROCK DESCRIPTION	Depth (ft)	Sample Type recovery	Sample No.	SPT Values (blw/6 in)	Qu (tsf)	Moisture Content (%)
	592.4	14-inch thick, black SILTY LOAM --TOPSOIL--															
	590.5	Medium dense, black and brown LOAM, some gravel and brick fragments --FILL--			1	6 10 10	NP	15						9	2 1 3	0.16 B	24
	590.5	Medium dense to dense, black and brown SILTY LOAM, trace gravel and brick fragments --FILL--	5		2	3 17 14	NP	57				25		10	2 2 2	0.25 B	20
	585.5	Gray, medium SAND, trace gravel			3	9 6 5	NP	22						11	2 1 2	0.33 B	24
	584.8	Very stiff, gray SILTY CLAY, trace gravel	10		4	2 3 6	3.36 B	23						12	1 2 3	0.16 B	26
	580.5	Very soft to medium stiff, gray CLAY to SILTY CLAY, trace gravel	15		5	5 6 7	3.03 B	26									
					6	2 1 2	0.33 B	27						13	1 2 2	0.16 B	25
					7	1 1 1	0.16 B	24									
					8	1 1 1	0.16 B	29						14	2 3 3	0.25 B	24

GENERAL NOTES

WATER LEVEL DATA

Begin Drilling **02-25-2014** Complete Drilling **02-28-2014**
 Drilling Contractor **Wang Testing Services** Drill Rig **D-25 ATV [93%]**
 Driller **N&J** Logger **A. Happel** Checked by **C. Marin**
 Drilling Method **2.25" HSA to 10', mud rotary thereafter, boring backfilled upon completion**

While Drilling ∇ **62.00 ft**
 At Completion of Drilling ∇ **mud in the borehole**
 Time After Drilling **NA**
 Depth to Water ∇ **NA**

The stratification lines represent the approximate boundary between soil types; the actual transition may be gradual.

WANGENGINC 11000401.GPJ WANGENG.GDT 8/25/17



wangeng@wangeng.com
 1145 N Main Street
 Lombard, IL 60148
 Telephone: 630 953-9928
 Fax: 630 953-9938

BORING LOG 15-RWB-01

WEI Job No.: 1100-04-01

Client: **AECOM**
 Project: **Circle Interchange Reconstruction**
 Location: **Section 17, T39N, R14E of 3rd PM**

Datum: NAVD 88
 Elevation: 593.54 ft
 North: 1897200.61 ft
 East: 1171415.26 ft
 Station: 1229+54.23
 Offset: 33.2105 RT

Profile	Elevation (ft)	SOIL AND ROCK DESCRIPTION	Depth (ft)	Sample Type recovery	Sample No.	SPT Values (blw/6 in)	Qu (tsf)	Moisture Content (%)	Profile	Elevation (ft)	SOIL AND ROCK DESCRIPTION	Depth (ft)	Sample Type recovery	Sample No.	SPT Values (blw/6 in)	Qu (tsf)	Moisture Content (%)	
	531.8									531.8	Dense, gray, medium SAND, trace gravel							
		--L _L (%)=34, P _L (%)= 18-- --%Gravel=4.4-- --%Sand=14.5-- --%Silt=47.7-- --%Clay=33.3-- --A-6 (12)--	45		15	3 4 5	0.50 P	25			--Moist to wet--	65		19	13 20 25		NP	24
			50		16	2 2 2	0.82 B	27			--HARD DRILLING-- --Possible Cobbles--	70		20	22 16 24		NP	24
	541.8	Hard, gray SILTY CLAY LOAM, trace gravel	55		17	14 18 30	5.33 S	13				75		21	14 18 21		NP	19
			60		18	14 22 26	6.72 S	13				80		22	18 39 50	4.50 P		13
										516.8	Hard, gray SILTY CLAY LOAM to SILTY LOAM, trace gravel							

GENERAL NOTES

Begin Drilling **02-25-2014** Complete Drilling **02-28-2014**
 Drilling Contractor **Wang Testing Services** Drill Rig **D-25 ATV [93%]**
 Driller **N&J** Logger **A. Happel** Checked by **C. Marin**
 Drilling Method **2.25" HSA to 10', mud rotary thereafter, boring backfilled upon completion**

WATER LEVEL DATA

While Drilling ∇ **62.00 ft**
 At Completion of Drilling ∇ **mud in the borehole**
 Time After Drilling **NA**
 Depth to Water ∇ **NA**

The stratification lines represent the approximate boundary between soil types; the actual transition may be gradual.

WANGENGINC 11000401.GPJ WANGENG.GDT 8/25/17



wangeng@wangeng.com
 1145 N Main Street
 Lombard, IL 60148
 Telephone: 630 953-9928
 Fax: 630 953-9938

BORING LOG 15-RWB-01

WEI Job No.: 1100-04-01

Client: **AECOM**
 Project: **Circle Interchange Reconstruction**
 Location: **Section 17, T39N, R14E of 3rd PM**

Datum: NAVD 88
 Elevation: 593.54 ft
 North: 1897200.61 ft
 East: 1171415.26 ft
 Station: 1229+54.23
 Offset: 33.2105 RT

Profile	Elevation (ft)	SOIL AND ROCK DESCRIPTION	Depth (ft)	Sample Type recovery	Sample No.	SPT Values (blw/6 in)	Qu (tsf)	Moisture Content (%)	Profile	Elevation (ft)	SOIL AND ROCK DESCRIPTION	Depth (ft)	Sample Type recovery	Sample No.	SPT Values (blw/6 in)	Qu (tsf)	Moisture Content (%)
	503.5		85		23	22 32 50	9.02 S	13									
		--L _L (%)=26, P _L (%)=16-- --%Gravel=0.1-- --%Sand=11.7-- --%Silt=62.6-- --%Clay=25.6-- --A-4 (7)--			24	25 33 48	10.25 S	13									
		Boring terminated at 90.00 ft	90														
			95														
			100														

GENERAL NOTES

WATER LEVEL DATA

Begin Drilling **02-25-2014** Complete Drilling **02-28-2014**
 Drilling Contractor **Wang Testing Services** Drill Rig **D-25 ATV [93%]**
 Driller **N&J** Logger **A. Happel** Checked by **C. Marin**
 Drilling Method **2.25" HSA to 10', mud rotary thereafter, boring backfilled upon completion**

While Drilling ∇ **62.00 ft**
 At Completion of Drilling ∇ **mud in the borehole**
 Time After Drilling **NA**
 Depth to Water ∇ **NA**

The stratification lines represent the approximate boundary between soil types; the actual transition may be gradual.



wangeng@wangeng.com
 1145 N Main Street
 Lombard, IL 60148
 Telephone: 630 953-9928
 Fax: 630 953-9938

BORING LOG 15-RWB-02

WEI Job No.: 1100-04-01

Client: **AECOM**
 Project: **Circle Interchange Reconstruction**
 Location: **Section 17, T39N, R14E of 3rd PM**

Datum: NAVD 88
 Elevation: 592.37 ft
 North: 1897034.79 ft
 East: 1171464.06 ft
 Station: 7314+69.17
 Offset: 7.23 LT

Profile	Elevation (ft)	SOIL AND ROCK DESCRIPTION	Depth (ft)	Sample Type recovery	Sample No.	SPT Values (blw/6 in)	Qu (tsf)	Moisture Content (%)	Profile	Elevation (ft)	SOIL AND ROCK DESCRIPTION	Depth (ft)	Sample Type recovery	Sample No.	SPT Values (blw/6 in)	Qu (tsf)	Moisture Content (%)
	591.4	12-inch thick, brown SANDY LOAM															
		--FILL--															
		Very stiff, gray SILTY CLAY LOAM, trace gravel and roots			1	3 6 7	2.05 S	17						9	0 0 2	0.41 B	24
	589.4	Medium dense, SILTY LOAM to SILTY CLAY LOAM, trace gravel, sand and brick			2	6 5 5	NP	17				25		10	0 0 0	0.74 B	30
		--FILL--															
	586.9	Very loose to loose, brown, fine SAND			3	3 4 4	NP	18						11	1 1 1	0.74 B	22
		--Wet--															
	582.9	Stiff, brown and gray SILTY CLAY, trace gravel	10		4	2 3 2	NP	17				30		12	0 2 2	0.57 B	23
					5	2 2 3	1.00 P	29									
					6	0 2 2	1.23 B	24				35		13	0 0 1	0.41 B	25
	576.9	Soft to medium stiff, gray CLAY to SILTY CLAY, trace gravel			7	0 2 2	0.82 B	24									
					8	0 1 2	0.57 B	24				40		14	0 1 2	0.41 B	25

GENERAL NOTES

Begin Drilling **04-03-2014** Complete Drilling **04-03-2014**
 Drilling Contractor **Wang Testing Services** Drill Rig **D-50 TMR [78%]**
 Driller **R&J** Logger **M. de los Reyes** Checked by **C. Marin**
 Drilling Method **2.25" SSA to 11', mud rotary thereafter, boring backfilled upon completion**

WATER LEVEL DATA

While Drilling ∇ **5.50 ft**
 At Completion of Drilling ∇ **mud in the borehole**
 Time After Drilling **NA**
 Depth to Water ∇ **NA**

The stratification lines represent the approximate boundary between soil types; the actual transition may be gradual.

WANGENGINC 11000401.GPJ WANGENG.GDT 8/25/17



BORING LOG 15-RWB-03

wangeng@wangeng.com
 1145 N Main Street
 Lombard, IL 60148
 Telephone: 630 953-9928
 Fax: 630 953-9938

WEI Job No.: 1100-04-01

Client: **AECOM**
 Project: **Circle Interchange Reconstruction**
 Location: **Section 17, T39N, R14E of 3rd PM**

Datum: NAVD 88
 Elevation: 580.75 ft
 North: 1896801.76 ft
 East: 1171517.06 ft
 Station: 6236+42.48
 Offset: 97.8444 RT

Profile	Elevation (ft)	SOIL AND ROCK DESCRIPTION	Depth (ft)	Sample Type recovery	Sample No.	SPT Values (blw/6 in)	Qu (tsf)	Moisture Content (%)	Profile	Elevation (ft)	SOIL AND ROCK DESCRIPTION	Depth (ft)	Sample Type recovery	Sample No.	SPT Values (blw/6 in)	Qu (tsf)	Moisture Content (%)
	534.0	Very dense, gray SILTY LOAM, trace gravel --Dry--	45	X	6	8 14 25	7.46 B	17		515.7	Boring terminated at 65.00 ft	65	X	10	9 11 11	NP	23
	529.0	Medium dense to dense, brown fine SAND --Moist--	50	X	7	13 28 38	NP	12				70					
			55	X	8	13 14 18	NP	21				75					
			60	X	9	9 13 14	NP	23				80					

GENERAL NOTES

WATER LEVEL DATA

Begin Drilling **08-08-2014** Complete Drilling **08-08-2014**
 Drilling Contractor **Wang Testing Services** Drill Rig **D-50 TMR [78%]**
 Driller **R&J** Logger **S. Woods** Checked by **C. Marin**
 Drilling Method **2.25 SSA to 10', mud rotary thereafter, boring backfilled upon completion**

While Drilling ∇ **52.00 ft**
 At Completion of Drilling ∇ **mud in the borehole**
 Time After Drilling **NA**
 Depth to Water ∇ **NA**

The stratification lines represent the approximate boundary between soil types; the actual transition may be gradual.

WANGENGINC 11000401.GPJ WANGENG.GDT 8/25/17



wangeng@wangeng.com
 1145 N Main Street
 Lombard, IL 60148
 Telephone: 630 953-9928
 Fax: 630 953-9938

BORING LOG 10-RWB-03

WEI Job No.: 1100-04-01

Client: **AECOM**
 Project: **Circle Interchange Reconstruction**
 Location: **Section 17, T39N, R14E of 3rd PM**

Datum: NAVD 88
 Elevation: 593.09 ft
 North: 1897135.88 ft
 East: 1171421.19 ft
 Station: 7313+60.00
 Offset: 3.91 RT

Profile	Elevation (ft)	SOIL AND ROCK DESCRIPTION	Depth (ft)	Sample Type recovery	Sample No.	SPT Values (blw/6 in)	Qu (tsf)	Moisture Content (%)	Profile	Elevation (ft)	SOIL AND ROCK DESCRIPTION	Depth (ft)	Sample Type recovery	Sample No.	SPT Values (blw/6 in)	Qu (tsf)	Moisture Content (%)
	592.2	11-inch thick, dark brown SILTY LOAM --TOPSOIL--															
		Medium dense, black and reddish brown SILTY LOAM, trace gravel --FILL--			1	16 9 10	NP	25						9	1 1 1	0.16 B	31
	589.1	Loose to medium dense, brown SAND, trace gravel --FILL--			2	5 7 10	NP	6				25		10	1 2 2	0.16 B	29
					3	2 2 2	NP	22						11	2 2 2	0.16 B	27
	584.3	Stiff to very stiff, gray CLAY, trace gravel			4	2 4 8	2.46 B	24				30		12	2 2 2	0.16 B	22
					5	4 4 5	2.46 B	28									
		--L _L (%)=37, P _L (%)=19-- --%Gravel=2.0-- --%Sand=15.8-- --%Silt= 39.6-- --%Clay=42.5-- --A-6 (14)--			6	2 3 4	2.21 B	22				35		13	2 1 3	0.16 B	26
					7	3 4 5	1.72 B	29									
	575.1	Very soft to medium stiff, gray CLAY to SILTY CLAY, trace gravel			8	2 1 2	0.33 B	28				40		14	2 2 2	0.25 B	25

GENERAL NOTES

Begin Drilling **02-21-2014** Complete Drilling **02-25-2014**
 Drilling Contractor **Wang Testing Services** Drill Rig **D-25 ATV [93%]**
 Driller **N&J** Logger **A. Happel** Checked by **C. Marin**
 Drilling Method **2.25" HSA to 10', mud rotary thereafter, boring backfilled upon completion**

WATER LEVEL DATA

While Drilling ∇ **59.00 ft**
 At Completion of Drilling ∇ **mud in the borehole**
 Time After Drilling **NA**
 Depth to Water ∇ **NA**

The stratification lines represent the approximate boundary between soil types; the actual transition may be gradual.

WANGENGINC 11000401.GPJ WANGENG.GDT 8/25/17



BORING LOG 10-RWB-03

wangeng@wangeng.com
 1145 N Main Street
 Lombard, IL 60148
 Telephone: 630 953-9928
 Fax: 630 953-9938

WEI Job No.: 1100-04-01

Client: **AECOM**
 Project: **Circle Interchange Reconstruction**
 Location: **Section 17, T39N, R14E of 3rd PM**

Datum: NAVD 88
 Elevation: 593.09 ft
 North: 1897135.88 ft
 East: 1171421.19 ft
 Station: 7313+60.00
 Offset: 3.91 RT

Profile	Elevation (ft)	SOIL AND ROCK DESCRIPTION	Depth (ft)	Sample Type recovery	Sample No.	SPT Values (blw/6 in)	Qu (tsf)	Moisture Content (%)	Profile	Elevation (ft)	SOIL AND ROCK DESCRIPTION	Depth (ft)	Sample Type recovery	Sample No.	SPT Values (blw/6 in)	Qu (tsf)	Moisture Content (%)
											--Moist to wet--						
			45	X	15	2 3 4	0.16 B	24				65	X	19	12 21 27	NP	22
	543.8	Hard, gray SILTY CLAY, trace gravel	50	X	16	3 5 6	0.90 B	26			--L _L (%)=NP, P _L (%)=NP-- --%Gravel=0.1-- --%Sand=44.4-- --%Silt=51.6-- --%Clay=4.0-- --A-4 (0)--	70	X	20	16 21 31	NP	21
			55	X	17	10 17 25	6.15 B	17				75	X	21	21 20 25	NP	22
	534.1	Dense to very dense, gray, fine SAND and SILT laminations	60	X	18	16 28 34	NP	17			Hard, gray SILTY CLAY LOAM to SILTY LOAM, trace gravel	80	X	22	18 27 31	4.50 P	14

GENERAL NOTES

WATER LEVEL DATA

Begin Drilling **02-21-2014** Complete Drilling **02-25-2014**
 Drilling Contractor **Wang Testing Services** Drill Rig **D-25 ATV [93%]**
 Driller **N&J** Logger **A. Happel** Checked by **C. Marin**
 Drilling Method **2.25" HSA to 10', mud rotary thereafter, boring backfilled upon completion**

While Drilling ∇ **59.00 ft**
 At Completion of Drilling ∇ **mud in the borehole**
 Time After Drilling **NA**
 Depth to Water ∇ **NA**

The stratification lines represent the approximate boundary between soil types; the actual transition may be gradual.

WANGENGINC 11000401.GPJ WANGENG.GDT 8/25/17



BORING LOG 10-RWB-03

wangeng@wangeng.com
 1145 N Main Street
 Lombard, IL 60148
 Telephone: 630 953-9928
 Fax: 630 953-9938

WEI Job No.: 1100-04-01

Client: **AECOM**
 Project: **Circle Interchange Reconstruction**
 Location: **Section 17, T39N, R14E of 3rd PM**

Datum: NAVD 88
 Elevation: 593.09 ft
 North: 1897135.88 ft
 East: 1171421.19 ft
 Station: 7313+60.00
 Offset: 3.91 RT

Profile	Elevation (ft)	SOIL AND ROCK DESCRIPTION	Depth (ft)	Sample Type recovery	Sample No.	SPT Values (blw/6 in)	Qu (tsf)	Moisture Content (%)	Profile	Elevation (ft)	SOIL AND ROCK DESCRIPTION	Depth (ft)	Sample Type recovery	Sample No.	SPT Values (blw/6 in)	Qu (tsf)	Moisture Content (%)
	506.3	Very dense, gray SILTY LOAM, trace to little gravel --Damp to dry--	85	✓	23	20 27 46	4.92 S	14		490.1	--DIFFICULT DRILLING-- --AUGER REFUSAL-- Boring terminated at 103.00 ft	105					
			90	✓	24	50/5	NP	12				110					
			95	✓	25	50/5	NP	14				115					
	495.6	--HARD DRILLING-- Very dense, gray DOLOSTONE fragments -- WEATHERED BEDROCK--	100	✓	26	50/1	NP	11				120					

GENERAL NOTES

WATER LEVEL DATA

Begin Drilling **02-21-2014** Complete Drilling **02-25-2014**
 Drilling Contractor **Wang Testing Services** Drill Rig **D-25 ATV [93%]**
 Driller **N&J** Logger **A. Happel** Checked by **C. Marin**
 Drilling Method **2.25" HSA to 10', mud rotary thereafter, boring backfilled upon completion**

While Drilling ∇ **59.00 ft**
 At Completion of Drilling ∇ **mud in the borehole**
 Time After Drilling **NA**
 Depth to Water ∇ **NA**

The stratification lines represent the approximate boundary between soil types; the actual transition may be gradual.

WANGENGINC 11000401.GPJ WANGENG.GDT 8/25/17



BORING LOG 10-RWB-04

wangeng@wangeng.com
 1145 N Main Street
 Lombard, IL 60148
 Telephone: 630 953-9928
 Fax: 630 953-9938

WEI Job No.: 1100-04-01

Client: **AECOM**
 Project: **Circle Interchange Reconstruction**
 Location: **Section 17, T39N, R14E of 3rd PM**

Datum: NAVD 88
 Elevation: 593.40 ft
 North: 1896930.29 ft
 East: 1171484.09 ft
 Station: 7315+75.12
 Offset: 1.47 RT

Profile	Elevation (ft)	SOIL AND ROCK DESCRIPTION	Depth (ft)	Sample Type recovery	Sample No.	SPT Values (blw/6 in)	Qu (tsf)	Moisture Content (%)	Profile	Elevation (ft)	SOIL AND ROCK DESCRIPTION	Depth (ft)	Sample Type recovery	Sample No.	SPT Values (blw/6 in)	Qu (tsf)	Moisture Content (%)
	592.9	6-inch thick ASPHALT --PAVEMENT--									gravel						
		Dense, brown GRAVELLY LOAM --BASE COURSE--			1	29 29 20	NP	16						9	0 0 1	0.08 B	36
	590.4	Very loose to medium dense, brown, coarse SAND --Dry to saturated-- --FILL--			2	6 9 7	NP	4				25		10	1 1 2	0.25 P	17
					3	3 3 4	NP	16						11	0 0 2	0.33 N/6	
					4	4 8 6	NP	6				30		12	1 1 1	0.16 B	27
					5	3 2 3	NP	7									
					6	2 2 1	NP	15				35		13	0 0 2	< 0.25 P	26
	577.9	Medium dense, gray GRAVELLY SAND --Wet--			7	3 7 9	NP	8									
	574.4	Very soft to medium stiff, gray CLAY to SILTY CLAY, trace			8	10 3 2	0.33 B	22				40		14	1 2 3	< 0.25 P	27

GENERAL NOTES

Begin Drilling **03-10-2014** Complete Drilling **03-13-2014**
 Drilling Contractor **Wang Testing Services** Drill Rig **CME-55 TMR [85%]**
 Driller **P&N** Logger **F. Bozga** Checked by **C. Marin**
 Drilling Method **2.25" SSA to 15', mud rotary thereafter, boring**
backfilled upon completion

WATER LEVEL DATA

While Drilling ∇ **13.00 ft**
 At Completion of Drilling ∇ **mud in the borehole**
 Time After Drilling **72 hours**
 Depth to Water ∇ **35.00 ft**

The stratification lines represent the approximate boundary between soil types; the actual transition may be gradual.

WANGENGINC 11000401.GPJ WANGENG.GDT 8/25/17



wangeng@wangeng.com
 1145 N Main Street
 Lombard, IL 60148
 Telephone: 630 953-9928
 Fax: 630 953-9938

BORING LOG 10-RWB-04

WEI Job No.: 1100-04-01

Client: **AECOM**
 Project: **Circle Interchange Reconstruction**
 Location: **Section 17, T39N, R14E of 3rd PM**

Datum: NAVD 88
 Elevation: 593.40 ft
 North: 1896930.29 ft
 East: 1171484.09 ft
 Station: 7315+75.12
 Offset: 1.47 RT

Profile	Elevation (ft)	SOIL AND ROCK DESCRIPTION	Depth (ft)	Sample Type recovery	Sample No.	SPT Values (blw/6 in)	Qu (tsf)	Moisture Content (%)	Profile	Elevation (ft)	SOIL AND ROCK DESCRIPTION	Depth (ft)	Sample Type recovery	Sample No.	SPT Values (blw/6 in)	Qu (tsf)	Moisture Content (%)
	511.7	--HARD DRILLING-- --Possible Cobbles--								492.4							
		Very dense, gray GRAVELLY SAND									Strong, light gray, fair rock mass quality, bedded fresh DOLOSTONE, up to 19-inch beds, 11-inch joint spacing, horizontal and vertical joints with none to more than 0.2-inch greenish gray infilling, hard joint wall, with stylolitic surfaces, and moderately vuggy porosity.						
		--Wet--	85	X	23	45 50/5	NP	10			--Run 1 - RECOVERY=96%-- --RQD=71%--	105		1			
		-HARD DRILLING up to 89.5 ft-- --Possible Cobbles--															
	503.9	Hard, gray SILTY LOAM, trace to little gravel	90		24	50/2	NP			482.4	Boring terminated at 111.00 ft						
		--Dry--															
			95	X	25	70/5	4.50 P	9									
		--HARD DRILLING at 97 ft-- --Possible Cobbles--															
	496.4	--WEATHERED BEDROCK--															
		--HARD DRILLING--	100		26	75/3	NP										

GENERAL NOTES

WATER LEVEL DATA

Begin Drilling **03-10-2014** Complete Drilling **03-13-2014**
 Drilling Contractor **Wang Testing Services** Drill Rig **CME-55 TMR [85%]**
 Driller **P&N** Logger **F. Bozga** Checked by **C. Marin**
 Drilling Method **2.25" SSA to 15', mud rotary thereafter, boring backfilled upon completion**

While Drilling ∇ **13.00 ft**
 At Completion of Drilling ∇ **mud in the borehole**
 Time After Drilling **72 hours**
 Depth to Water ∇ **35.00 ft**

The stratification lines represent the approximate boundary between soil types; the actual transition may be gradual.

WANGENGINC 11000401.GPJ WANGENG.GDT 8/25/17

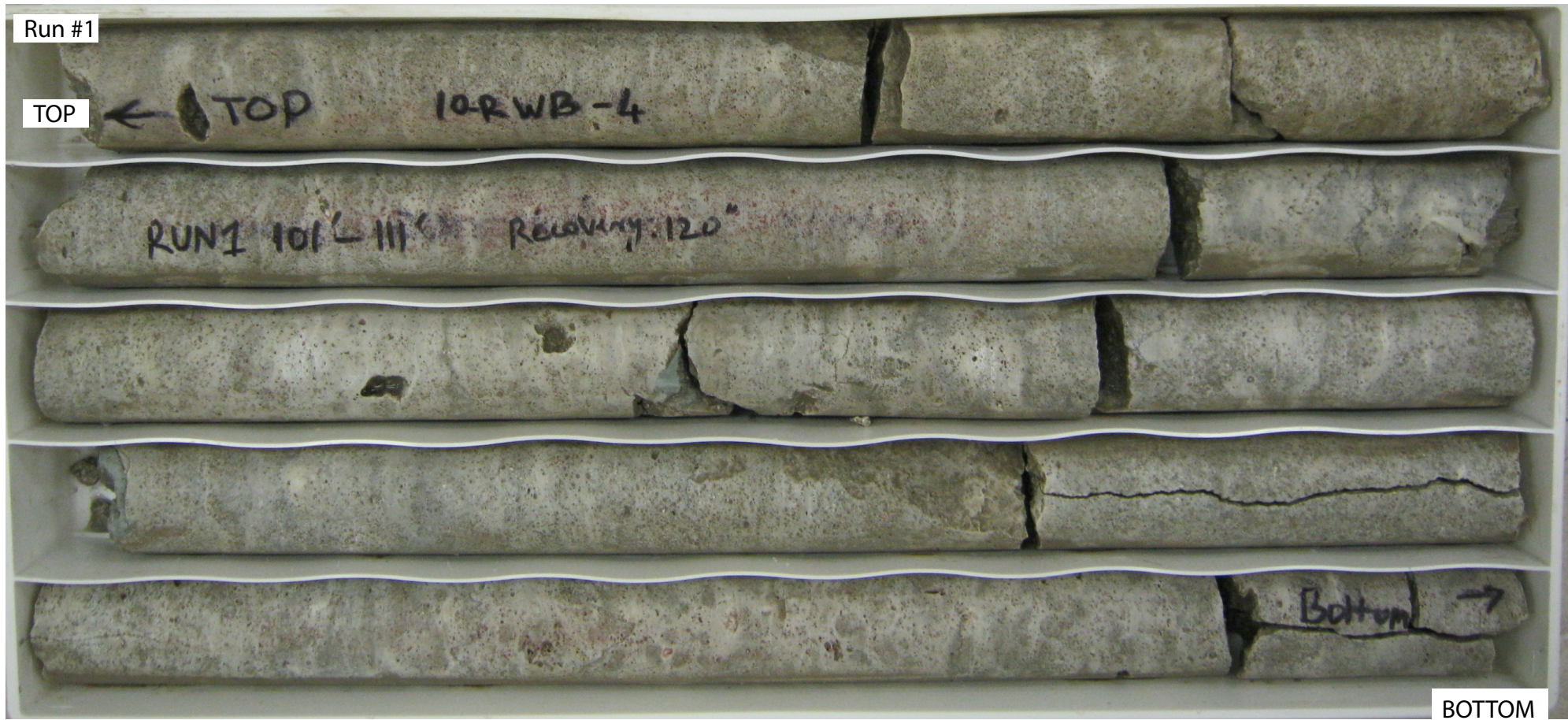

Boring 10-RWB-04:
Run #1, 101' to 111', RECOVERY = 100% , RQD = 71%

BEDROCK CORE: CIRCLE INTERCHANGE RECONSTRUCTION, RETAINING WALL 10, SN 016-1729, CHICAGO, IL		
SCALE : GRAPHIC	10-RWB-04	DRAWN BY: M. de los Reyes CHECKED BY: C. Marin
		1145 N. Main Street Lombard, IL 60148 www.wangeng.com
FOR AECOM		1100-04-01



wangeng@wangeng.com
 1145 N Main Street
 Lombard, IL 60148
 Telephone: 630 953-9928
 Fax: 630 953-9938

BORING LOG 10-RWB-05

WEI Job No.: 1100-04-01

Client: **AECOM**
 Project: **Circle Interchange Reconstruction**
 Location: **Section 17, T39N, R14E of 3rd PM**

Datum: NAVD 88
 Elevation: 580.22 ft
 North: 1896756.05 ft
 East: 1171508.19 ft
 Station: 6236+85.54
 Offset: 115.5731 RT

Profile	Elevation (ft)	SOIL AND ROCK DESCRIPTION	Depth (ft)	Sample Type recovery	Sample No.	SPT Values (blw/6 in)	Qu (tsf)	Moisture Content (%)	Profile	Elevation (ft)	SOIL AND ROCK DESCRIPTION	Depth (ft)	Sample Type recovery	Sample No.	SPT Values (blw/6 in)	Qu (tsf)	Moisture Content (%)
	579.94	4-inch thick ASPHALT --PAVEMENT--															
	578.7	14-inch thick CONCRETE --PAVEMENT--															
	576.2	Very dense, grayish white SANDY GRAVEL --FILL--			1	12 28 33	NP	5						9	0 0 0	0.33 B	27
		Very soft to medium stiff, gray CLAY to SILTY CLAY, trace gravel	5		2	4 2 2	0.74 B	24				25		10	0 1 1	0.25 B	27
					3	1 2 2	0.60 P	20						11	0 1 2	< 0.25 P	26
					4	0 1 2	0.41 B	23						12	0 0 2	0.41 B	27
					5	0 0 0	0.25 B	26									
					6	0 0 0	0.25 B	26						13	1 2 2	< 0.25 P	32
					7	0 0 2	< 0.25 P	29		543.5	Medium dense, SILTY LOAM, trace gravel						
					8	0 0 1	< 0.25 P	31						14	5 7 14	NP	24

GENERAL NOTES

Begin Drilling **07-31-2014** Complete Drilling **07-31-2014**
 Drilling Contractor **Wang Testing Services** Drill Rig **D-50 TMR [78%]**
 Driller **R&J** Logger **S. Woods** Checked by **C. Marin**
 Drilling Method **2.25" SSA to 15', mud rotary thereafter, boring**
backfilled upon completion

WATER LEVEL DATA

While Drilling ∇ **59.50 ft**
 At Completion of Drilling ∇ **mud in the borehole**
 Time After Drilling **NA**
 Depth to Water ∇ **NA**

The stratification lines represent the approximate boundary between soil types; the actual transition may be gradual.

WANGENGINC 11000401.GPJ WANGENG.GDT 8/25/17



BORING LOG 10-RWB-05

wangeng@wangeng.com
 1145 N Main Street
 Lombard, IL 60148
 Telephone: 630 953-9928
 Fax: 630 953-9938

WEI Job No.: 1100-04-01

Client: **AECOM**
 Project: **Circle Interchange Reconstruction**
 Location: **Section 17, T39N, R14E of 3rd PM**

Datum: NAVD 88
 Elevation: 580.22 ft
 North: 1896756.05 ft
 East: 1171508.19 ft
 Station: 6236+85.54
 Offset: 115.5731 RT

Profile	Elevation (ft)	SOIL AND ROCK DESCRIPTION	Depth (ft)	Sample Type recovery	Sample No.	SPT Values (blw/6 in)	Qu (tsf)	Moisture Content (%)	Profile	Elevation (ft)	SOIL AND ROCK DESCRIPTION	Depth (ft)	Sample Type recovery	Sample No.	SPT Values (blw/6 in)	Qu (tsf)	Moisture Content (%)	
	538.5	Hard, gray SILTY CLAY, trace gravel							7.13 B		Dense, gray SILTY LOAM, trace gravel Boring terminated at 65.00 ft							
	45			15	6 13 29		18			515.7 515.2		65	19 25 18	NP	12			
	533.5	Very dense, gray SILTY LOAM, trace gravel																
			50		16	11 27 39	NP	11				70						
	525.7	Medium dense to dense, gray, fine SAND, trace gravel							NP									
	55			17	12 18 24		15			75								
			60		18	10 11 14	NP	23				80						

GENERAL NOTES

WATER LEVEL DATA

Begin Drilling **07-31-2014** Complete Drilling **07-31-2014**
 Drilling Contractor **Wang Testing Services** Drill Rig **D-50 TMR [78%]**
 Driller **R&J** Logger **S. Woods** Checked by **C. Marin**
 Drilling Method **2.25" SSA to 15', mud rotary thereafter, boring backfilled upon completion**

While Drilling ∇ **59.50 ft**
 At Completion of Drilling ∇ **mud in the borehole**
 Time After Drilling **NA**
 Depth to Water ∇ **NA**

The stratification lines represent the approximate boundary between soil types; the actual transition may be gradual.

WANGENGINC 11000401.GPJ WANGENG.GDT 8/25/17



wangeng@wangeng.com
 1145 N Main Street
 Lombard, IL 60148
 Telephone: 630 953-9928
 Fax: 630 953-9938

BORING LOG 10-PZ-01

WEI Job No.: 1100-04-01

Client: **AECOM**
 Project: **Circle Interchange Reconstruction**
 Location: **Section 17, T39N, R14E of 3rd PM**

Datum: NAVD 88
 Elevation: 592.93 ft
 North: 1897019.14 ft
 East: 1171462.69 ft
 Station: 7315+23.85
 Offset: 4.45 LT

Profile	Elevation (ft)	SOIL AND ROCK DESCRIPTION	Depth (ft)	Sample Type recovery	Sample No.	SPT Values (blw/6 in)	Qu (tsf)	Moisture Content (%)	Profile	Elevation (ft)	SOIL AND ROCK DESCRIPTION	Depth (ft)	Sample Type recovery	Sample No.	SPT Values (blw/6 in)	Qu (tsf)	Moisture Content (%)
		--Drilled without sampling--	5									25					
			10									30					
			15									35					
			20									40					

Piezometer Data:
 --Installed in Dec. 11, 2014
 --Bentonite Seal 66 to 71 feet
 --Top of Sand Pack at 71 feet
 --Top of Screen at 73 feet
 --Screen Length 20 feet
 --Bottom of Screen at 93 feet

GENERAL NOTES

Begin Drilling **12-10-2014** Complete Drilling **12-11-2014**
 Drilling Contractor **Wang Testing Services** Drill Rig **B-57 TMR [100%]**
 Driller **P&P** Logger **A. Happel** Checked by **C. Marin**
 Drilling Method **4.25" HSA, monitoring water well; pizometer**
installed on 12/11/2014

WATER LEVEL DATA

While Drilling ∇ **68.00 ft**
 At Completion of Drilling \blacktriangledown **74.00 ft**
 Time After Drilling **24 hours**
 Depth to Water ∇ **45.04 ft**

The stratification lines represent the approximate boundary between soil types; the actual transition may be gradual.



wangeng@wangeng.com
 1145 N Main Street
 Lombard, IL 60148
 Telephone: 630 953-9928
 Fax: 630 953-9938

BORING LOG 10-PZ-01

WEI Job No.: 1100-04-01

Client: **AECOM**
 Project: **Circle Interchange Reconstruction**
 Location: **Section 17, T39N, R14E of 3rd PM**

Datum: NAVD 88
 Elevation: 592.93 ft
 North: 1897019.14 ft
 East: 1171462.69 ft
 Station: 7315+23.85
 Offset: 4.45 LT

Profile	Elevation (ft)	SOIL AND ROCK DESCRIPTION	Depth (ft)	Sample Type recovery	Sample No.	SPT Values (blw/6 in)	Qu (tsf)	Moisture Content (%)	Profile	Elevation (ft)	SOIL AND ROCK DESCRIPTION	Depth (ft)	Sample Type recovery	Sample No.	SPT Values (blw/6 in)	Qu (tsf)	Moisture Content (%)
	506.2		85	3	3	50/6	NP	16									
		Very dense, gray SILTY LOAM, trace gravel		4	4	50/3	4.50 P	9									
		--Moist--	90														
		--Wet--		5	5	50/5	NP	11									
	497.9	--HARD DRILLING--	95														
		Boring terminated at 95.00 ft															

GENERAL NOTES

WATER LEVEL DATA

Begin Drilling **12-10-2014** Complete Drilling **12-11-2014**
 Drilling Contractor **Wang Testing Services** Drill Rig **B-57 TMR [100%]**
 Driller **P&P** Logger **A. Happel** Checked by **C. Marin**
 Drilling Method **4.25" HSA, monitoring water well; pizometer**
installed on 12/11/2014

While Drilling ∇ **68.00 ft**
 At Completion of Drilling \blacktriangledown **74.00 ft**
 Time After Drilling **24 hours**
 Depth to Water ∇ **45.04 ft**

The stratification lines represent the approximate boundary between soil types; the actual transition may be gradual.



BORING LOG 1729-VST-01

wangeng@wangeng.com
 1145 N Main Street
 Lombard, IL 60148
 Telephone: 630 953-9928
 Fax: 630 953-9938

WEI Job No.: 1100-04-01

Client: **AECOM**
 Project: **Circle Interchange Reconstruction**
 Location: **Section 17, T39N, R14E of 3rd PM**

Datum: NAVD 88
 Elevation: 598.29 ft
 North: 1897455.09 ft
 East: 1171356.40 ft
 Station: 7310+33.97
 Offset: 1.45 RT

Profile	Elevation (ft)	SOIL AND ROCK DESCRIPTION	Depth (ft)	Sample Type recovery	Sample No.	SPT Values (blw/6 in)	Qu (tsf)	Moisture Content (%)	Profile	Elevation (ft)	SOIL AND ROCK DESCRIPTION	Depth (ft)	Sample Type recovery	Sample No.	SPT Values (blw/6 in)	Qu (tsf)	Moisture Content (%)	
		Drilled without sampling																
			5								--In-Situ Vane Shear, 25.0 feet--	25	1					
											--S _{u undis} = 926.51 psf--							
											--S _{u remold} = 452.48 psf--							
											--Sensitivity = 2.05--							
			10								--In-Situ Vane Shear, 30.0 feet--	30	2					
											--S _{u undis} = 603.30 psf--							
											--S _{u remold} = 344.75 psf--							
											--Sensitivity = 1.75--							
	584.8	Medium dense, brown and black SANDY LOAM; trace gravel; trace brick and wood fragments; mosit	15		1	4 6 5	NP	20			--In-Situ Vane Shear, 35.0 feet--	35	3					
	583.0	--FILL-- Stiff, gray SILTY CLAY LOAM, trace gravel			2	3 3 4	1.07 B	21			--In-Situ Vane Shear, 40.0 feet--	40	4					
	581.0	--FILL-- Medium stiff, gray SILTY CLAY, trace gravel			3	2 3 3	0.57 B	21										

GENERAL NOTES

Begin Drilling **07-25-2016** Complete Drilling **07-26-2016**
 Drilling Contractor **Wang Testing Services** Drill Rig **D-25 ATV [93%]**
 Driller **N&N** Logger **F. Bozga** Checked by **M. Seyhun**
 Drilling Method **2.25" IDA HSA to 10', mud rotary thereafter, boring backfilled upon completion**

WATER LEVEL DATA

While Drilling **Rotary wash**
 At Completion of Drilling **Mud at 20 ft**
 Time After Drilling **NA**
 Depth to Water **NA**

The stratification lines represent the approximate boundary between soil types; the actual transition may be gradual.

WANGENGINC 11000401.GPJ WANGENG.GDT 8/25/17



wangeng@wangeng.com
 1145 N Main Street
 Lombard, IL 60148
 Telephone: 630 953-9928
 Fax: 630 953-9938

BORING LOG 1729-VST-01

WEI Job No.: 1100-04-01

Client: **AECOM**
 Project: **Circle Interchange Reconstruction**
 Location: **Section 17, T39N, R14E of 3rd PM**

Datum: NAVD 88
 Elevation: 598.29 ft
 North: 1897455.09 ft
 East: 1171356.40 ft
 Station: 7310+33.97
 Offset: 1.45 RT

Profile	Elevation (ft)	SOIL AND ROCK DESCRIPTION	Depth (ft)	Sample Type recovery	Sample No.	SPT Values (blw/6 in)	Qu (tsf)	Moisture Content (%)	Profile	Elevation (ft)	SOIL AND ROCK DESCRIPTION	Depth (ft)	Sample Type recovery	Sample No.	SPT Values (blw/6 in)	Qu (tsf)	Moisture Content (%)
		--S _{u undis} = 635.62 psf-- --S _{u remold} = 355.52 psf-- --Sensitivity = 1.78--				VS											
		--In-Situ Vane Shear, 45.0 feet--	45		5	VS											
		--S _{u undis} = 840.32 psf-- --S _{u remold} = 430.93 psf-- --Sensitivity = 1.95--															
			50		4	4 5 5	0.57 B	27									
					5	2 3 3	0.41 B	29									
		--In-Situ Vane Shear, 54.5 feet--	55		6	VS											
	542.8	--S _{u undis} = 1508.26 psf-- --S _{u remold} = 1249.71 psf-- --Sensitivity = 1.21--															
		Very stiff, gray SILTY CLAY, trace gravel			6	5 10 16	2.46 B	22									
	540.8	Boring terminated at 57.50 ft															
			60														

GENERAL NOTES

Begin Drilling **07-25-2016** Complete Drilling **07-26-2016**
 Drilling Contractor **Wang Testing Services** Drill Rig **D-25 ATV [93%]**
 Driller **N&N** Logger **F. Bozga** Checked by **M. Seyhun**
 Drilling Method **2.25" IDA HSA to 10', mud rotary thereafter, boring backfilled upon completion**

WATER LEVEL DATA

While Drilling **Rotary wash**
 At Completion of Drilling **Mud at 20 ft**
 Time After Drilling **NA**
 Depth to Water **NA**

The stratification lines represent the approximate boundary between soil types; the actual transition may be gradual.

WANGENGINC 11000401.GPJ WANGENG.GDT 8/25/17



BORING LOG 1729-VST-02

wangeng@wangeng.com
 1145 N Main Street
 Lombard, IL 60148
 Telephone: 630 953-9928
 Fax: 630 953-9938

WEI Job No.: 1100-04-01

Client: **AECOM**
 Project: **Circle Interchange Reconstruction**
 Location: **Section 17, T39N, R14E of 3rd PM**

Datum: NAVD 88
 Elevation: 592.70 ft
 North: 1897206.55 ft
 East: 1171441.79 ft
 Station: 7312+95.08
 Offset: 32.79 LT

Profile	Elevation (ft)	SOIL AND ROCK DESCRIPTION	Depth (ft)	Sample Type recovery	Sample No.	SPT Values (blw/6 in)	Qu (tsf)	Moisture Content (%)	Profile	Elevation (ft)	SOIL AND ROCK DESCRIPTION	Depth (ft)	Sample Type recovery	Sample No.	SPT Values (blw/6 in)	Qu (tsf)	Moisture Content (%)
		Drilled without sampling															
			5									25		2	2 3 5	< 0.25 P	23
											--In-Situ Vane Shear, 27.0 feet-- --Failed test--			1	VS		
											--In-Situ Vane Shear, 30.0 feet-- --S _{u undis} = 624.85 psf-- --S _{u remold} = 409.38 psf-- --Sensitivity = 1.53--			2	VS		
											--In-Situ Vane Shear, 35.0 feet-- --S _{u undis} = 603.31 psf-- --S _{u remold} = 387.84 psf-- --Sensitivity = 1.56--			3	VS		
	574.2	Very soft to medium stiff, gray SILTY CLAY, trace gravel			1	2 2 3	NR				--In-Situ Vane Shear, 40.0 feet--			4			

GENERAL NOTES

WATER LEVEL DATA

Begin Drilling **07-27-2016** Complete Drilling **07-27-2016**
 Drilling Contractor **Wang Testing Services** Drill Rig **D-25 ATV [93%]**
 Driller **N&N** Logger **F. Bozga** Checked by **M. Seyhun**
 Drilling Method **2.25" IDA HSA to 10', mud rotary thereafter, boring backfilled upon completion**

While Drilling **Rotary wash**
 At Completion of Drilling **Mud at 22.5 ft**
 Time After Drilling **NA**
 Depth to Water **NA**

The stratification lines represent the approximate boundary between soil types; the actual transition may be gradual.

WANGENGINC 11000401.GPJ WANGENG.GDT 8/25/17



wangeng@wangeng.com
 1145 N Main Street
 Lombard, IL 60148
 Telephone: 630 953-9928
 Fax: 630 953-9938

BORING LOG 1729-VST-02

WEI Job No.: 1100-04-01

Client: **AECOM**
 Project: **Circle Interchange Reconstruction**
 Location: **Section 17, T39N, R14E of 3rd PM**

Datum: NAVD 88
 Elevation: 592.70 ft
 North: 1897206.55 ft
 East: 1171441.79 ft
 Station: 7312+95.08
 Offset: 32.79 LT

Profile	Elevation (ft)	SOIL AND ROCK DESCRIPTION	Depth (ft)	Sample Type recovery	Sample No.	SPT Values (blw/6 in)	Qu (tsf)	Moisture Content (%)	Profile	Elevation (ft)	SOIL AND ROCK DESCRIPTION	Depth (ft)	Sample Type recovery	Sample No.	SPT Values (blw/6 in)	Qu (tsf)	Moisture Content (%)
		--S _{u undis} = 743.36 psf-- --S _{u remold} = 452.48 psf-- --Sensitivity = 1.64--															
		--In-Situ Vane Shear, 45.0 feet-- --Failed test--	45		5	VS											
		--In-Situ Vane Shear, 47.5 feet-- --S _{u undis} = 1422.08 psf-- --S _{u remold} = 775.68 psf-- --Sensitivity = 1.83--			6	VS											
		--In-Situ Vane Shear, 49.5 feet-- --S _{u undis} = 1422.07 psf-- --S _{u remold} = 775.68 psf-- --Sensitivity = 1.83--	50		7	VS											
					3		0.50 P	23									
	540.4 540.2	Hard, gray SILTY CLAY, trace gravel Boring terminated at 52.50 ft															
			55														
			60														

GENERAL NOTES

Begin Drilling **07-27-2016** Complete Drilling **07-27-2016**
 Drilling Contractor **Wang Testing Services** Drill Rig **D-25 ATV [93%]**
 Driller **N&N** Logger **F. Bozga** Checked by **M. Seyhun**
 Drilling Method **2.25" IDA HSA to 10', mud rotary thereafter, boring backfilled upon completion**

WATER LEVEL DATA

While Drilling **Rotary wash**
 At Completion of Drilling **Mud at 22.5 ft**
 Time After Drilling **NA**
 Depth to Water **NA**

The stratification lines represent the approximate boundary between soil types; the actual transition may be gradual.



wangeng@wangeng.com
 1145 N Main Street
 Lombard, IL 60148
 Telephone: 630 953-9928
 Fax: 630 953-9938

BORING LOG VST-01

WEI Job No.: 1100-04-01

Client: **AECOM**
 Project: **Circle Interchange Reconstruction**
 Location: **Section 17, T39N, R14E of 3rd PM**

Datum: NAVD 88
 Elevation: 593.55 ft
 North: 1897108.36 ft
 East: 1171435.63 ft
 Station: 7313+90.47
 Offset: 2.00 LT

Profile	Elevation (ft)	SOIL AND ROCK DESCRIPTION	Depth (ft)	Sample Type recovery	Sample No.	SPT Values (blw/6 in)	Qu (tsf)	Moisture Content (%)	Profile	Elevation (ft)	SOIL AND ROCK DESCRIPTION	Depth (ft)	Sample Type recovery	Sample No.	SPT Values (blw/6 in)	Qu (tsf)	Moisture Content (%)
		Very stiff, brown SILTY CLAY LOAM, trace gravel									--S _{u undis} = 786.3 psf-- --S _{u remold} = 371.3 psf-- --Sensitivity = 2.1--						
	590.5	--FILL--			1	3 5 7	2.75 P	14			--In-Situ Vane Shear, 22.0 feet-- --S _{u undis} = 742.6 psf-- --S _{u remold} = 305.8 psf-- --Sensitivity = 2.4--			2			
		Medium dense, fine SAND			2	5 5 6	NP	7			--In-Situ Vane Shear, 24.5 feet--	25		3			
	586.8										--S _{u undis} = 578.8 psf-- --S _{u remold} = 382.2 psf-- --Sensitivity = 1.5--						
		Medium stiff to stiff, gray SILTY CLAY			3	2 2 3	1.31 B	26			--In-Situ Vane Shear, 27.0 feet-- --S _{u undis} = 742.6 psf-- --S _{u remold} = 415.0 psf-- --Sensitivity = 1.8--			4			
											--In-Situ Vane Shear, 29.5 feet-- --S _{u undis} = 589.7 psf-- --S _{u remold} = 283.9 psf-- --Sensitivity = 2.1--			5			
					4	2 2 3	0.98 B	28			--In-Situ Vane Shear, 32.0 feet-- --S _{u undis} = 1026.6 psf-- --S _{u remold} = 447.8 psf-- --Sensitivity = 2.3--			6			
	578.0										--In-Situ Vane Shear, 34.5 feet-- --S _{u undis} = 764.5 psf-- --S _{u remold} = 480.5 psf-- --Sensitivity = 1.6--			7			
		Soft, gray SILTY CLAY			5	1 2 2	0.25 P	29			--In-Situ Vane Shear, 37.0 feet-- --S _{u undis} = 1026.6 psf-- --S _{u remold} = 589.7 psf-- --Sensitivity = 1.7--			8			
	575.3																
		--In-Situ Vane Shear, 19.5 feet--			1							40					

GENERAL NOTES

Begin Drilling **12-01-2015** Complete Drilling **12-01-2015**
 Drilling Contractor **Wang Testing Services** Drill Rig **CME-55 TMR [85%]**
 Driller **R&N** Logger **F. Bozga** Checked by **A. Kurnia**
 Drilling Method **2.25" HSA to 10', mud rotary thereafter, boring**
backfilled upon completion

WATER LEVEL DATA

While Drilling **Rotary wash**
 At Completion of Drilling **mud in the borehole**
 Time After Drilling **NA**
 Depth to Water **NA**

The stratification lines represent the approximate boundary between soil types; the actual transition may be gradual.

WANGENGINC 11000401.GPJ WANGENG.GDT 8/25/17



wangeng@wangeng.com
 1145 N Main Street
 Lombard, IL 60148
 Telephone: 630 953-9928
 Fax: 630 953-9938

BORING LOG VST-01

WEI Job No.: 1100-04-01

Client: **AECOM**
 Project: **Circle Interchange Reconstruction**
 Location: **Section 17, T39N, R14E of 3rd PM**

Datum: NAVD 88
 Elevation: 593.55 ft
 North: 1897108.36 ft
 East: 1171435.63 ft
 Station: 7313+90.47
 Offset: 2.00 LT

Profile	Elevation (ft)	SOIL AND ROCK DESCRIPTION	Depth (ft)	Sample Type recovery	Sample No.	SPT Values (blw/6 in)	Qu (tsf)	Moisture Content (%)	Profile	Elevation (ft)	SOIL AND ROCK DESCRIPTION	Depth (ft)	Sample Type recovery	Sample No.	SPT Values (blw/6 in)	Qu (tsf)	Moisture Content (%)
	544.0																
		--Equipment Slipped--	45		9	VS											
		--In-Situ Vane Shear, 46.5 feet-- -- $S_{u\ undis}$ = 1070.2 psf-- -- $S_{u\ remold}$ = 633.4 psf-- --Sensitivity = 1.7--			10	VS											
		--In-Situ Vane Shear, 49.0 feet-- -- $S_{u\ undis}$ = 1157.6 psf-- -- $S_{u\ remold}$ = 611.6 psf-- --Sensitivity = 2.3-- Boring terminated at 49.50 ft	50		11	VS											
			55														
			60														

GENERAL NOTES

Begin Drilling **12-01-2015** Complete Drilling **12-01-2015**
 Drilling Contractor **Wang Testing Services** Drill Rig **CME-55 TMR [85%]**
 Driller **R&N** Logger **F. Bozga** Checked by **A. Kurnia**
 Drilling Method **2.25" HSA to 10', mud rotary thereafter, boring backfilled upon completion**

WATER LEVEL DATA

While Drilling ∇ **Rotary wash**
 At Completion of Drilling ∇ **mud in the borehole**
 Time After Drilling **NA**
 Depth to Water ∇ **NA**

The stratification lines represent the approximate boundary between soil types; the actual transition may be gradual.

APPENDIX B

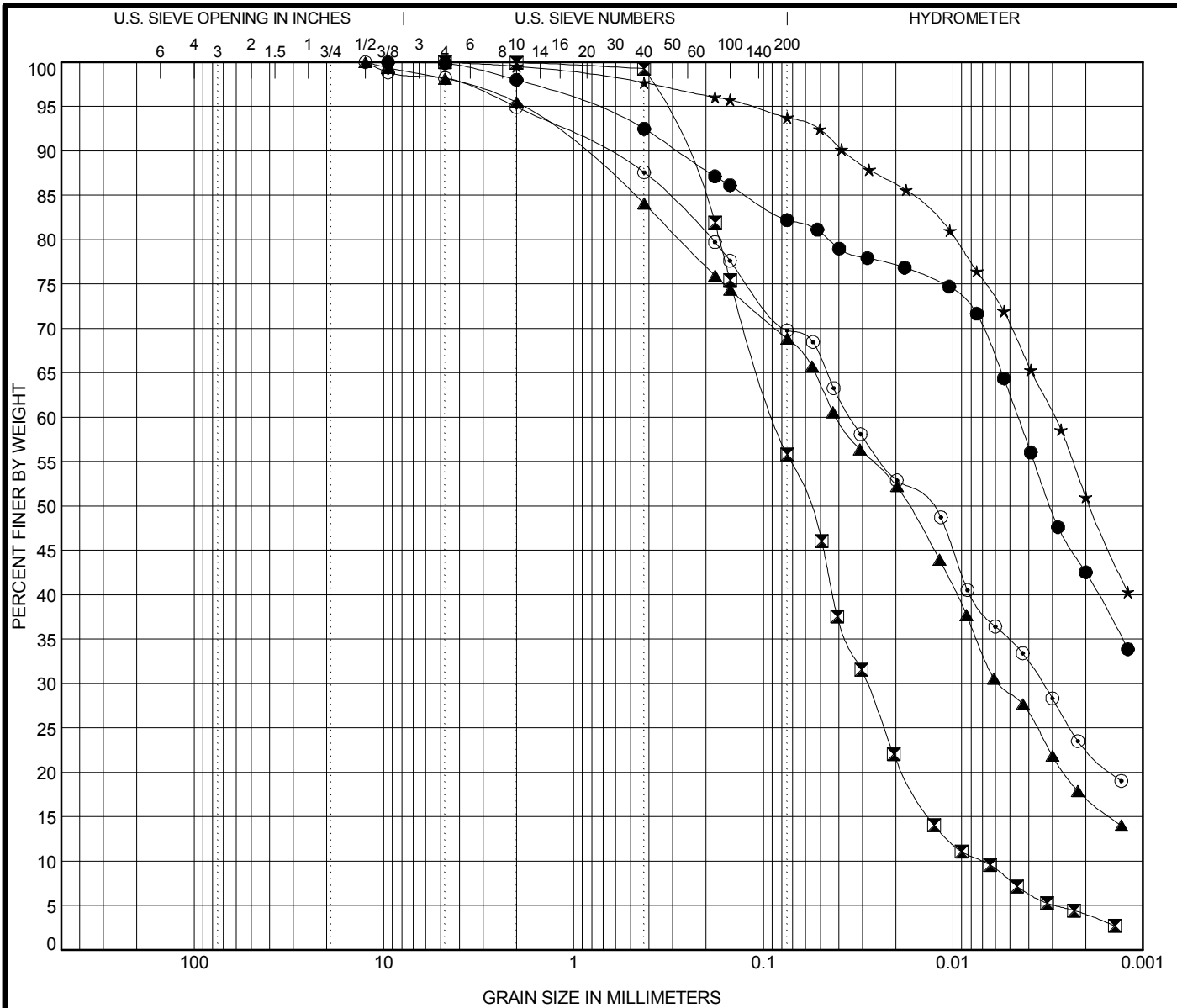

COBBLES	GRAVEL	SAND		SILT AND CLAY
		coarse	fine	

Specimen Identification			IDH Classification					LL	PL	PI	Cc	Cu
●	10-RWB-03#6	13.5 ft	Clay					37	19	18		
☒	10-RWB-03#20	68.5 ft	Silty Loam					NP	NP	NP	1.33	12.36
▲	10-RWB-04#18	58.5 ft	Silty Loam					24	14	10		
★	14-RWB-02#14	38.5 ft	Clay					41	18	23		
⊙	14-RWB-03#16	48.5 ft	Clay Loam					26	15	11		
Specimen Identification			D100	D60	D30	D10	%Gravel	%Sand	%Silt	%Clay		
●	10-RWB-03#6	13.5 ft	9.5	0.005			2.0	15.8	39.6	42.5		
☒	10-RWB-03#20	68.5 ft	4.75	0.087	0.029	0.007	0.1	44.4	51.6	4.0		
▲	10-RWB-04#18	58.5 ft	12.5	0.041	0.006		4.5	26.8	51.5	17.2		
★	14-RWB-02#14	38.5 ft	4.75	0.003			0.5	5.8	42.7	51.0		
⊙	14-RWB-03#16	48.5 ft	12.5	0.035	0.003		5.1	25.2	47.0	22.7		

WEI GRAIN SIZE IDH 11000401.GPJ US_LAB.GDT 8/24/17



Wang Engineering, Inc.
 1145 N Main Street
 Lombard, IL 60148
 Telephone: 630 953-9928
 Fax: 630 953-9938

GRAIN SIZE DISTRIBUTION

Project: Circle Interchange Reconstruction
 Location: Section 17, T39N, R14E of 3rd PM
 Number: 1100-04-01

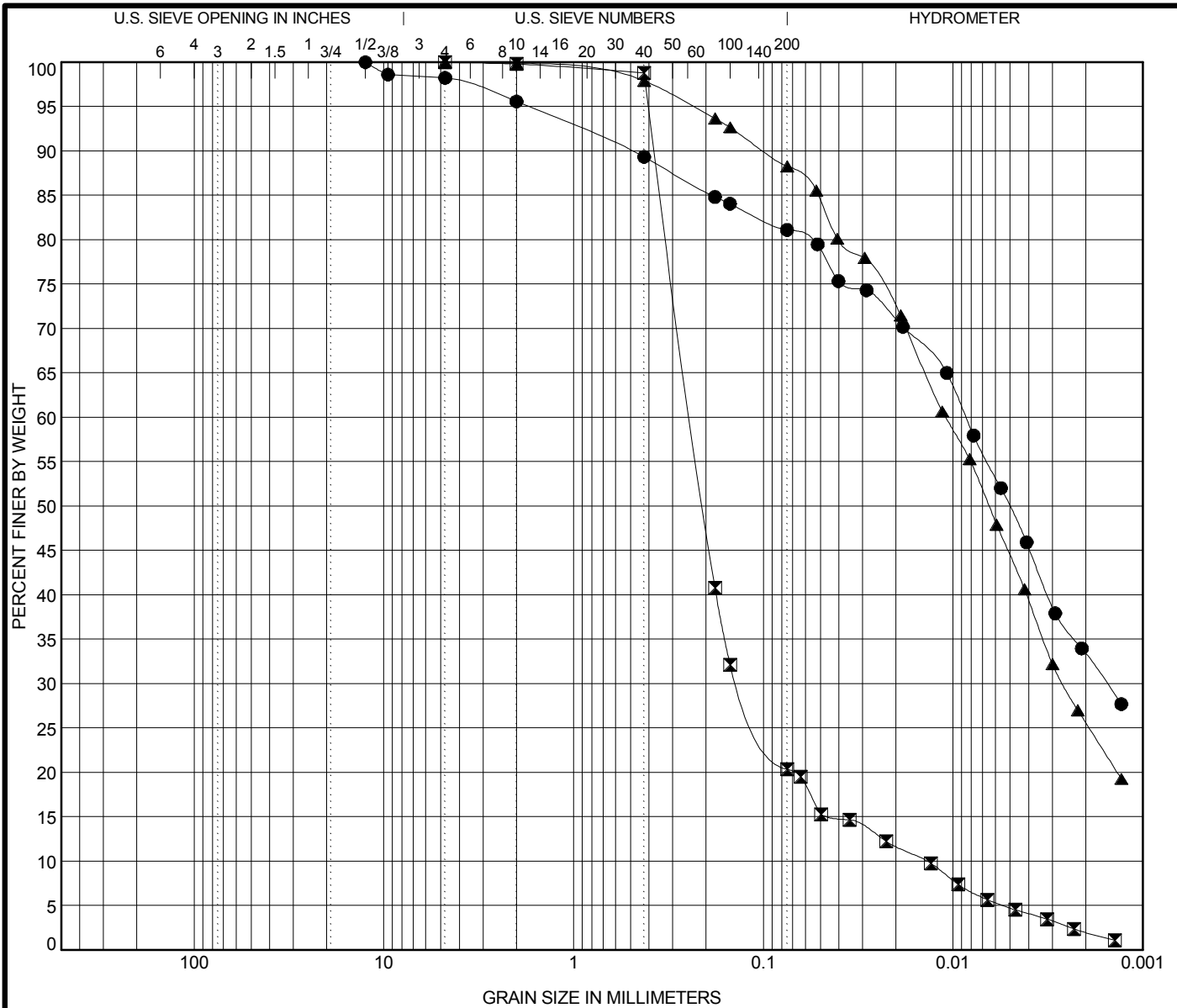

COBBLES	GRAVEL	SAND		SILT AND CLAY
		coarse	fine	

Specimen Identification	IDH Classification	LL	PL	PI	Cc	Cu
● 15-RWB-01#15 43.5 ft	Clay	34	18	16		
☒ 15-RWB-01#20 68.5 ft	Sandy Loam	NP	NP	NP	5.29	17.33
▲ 15-RWB-01#24 88.5 ft	Silty Clay Loam	26	16	10		

Specimen Identification	D100	D60	D30	D10	%Gravel	%Sand	%Silt	%Clay
● 15-RWB-01#15 43.5 ft	12.5	0.009	0.002		4.4	14.5	47.7	33.3
☒ 15-RWB-01#20 68.5 ft	4.75	0.239	0.132	0.014	0.2	79.5	18.3	2.0
▲ 15-RWB-01#24 88.5 ft	4.75	0.011	0.003		0.1	11.7	62.6	25.6



Wang Engineering, Inc.
 1145 N Main Street
 Lombard, IL 60148
 Telephone: 630 953-9928
 Fax: 630 953-9938

GRAIN SIZE DISTRIBUTION

Project: Circle Interchange Reconstruction
 Location: Section 17, T39N, R14E of 3rd PM
 Number: 1100-04-01

WEI GRAIN SIZE IDH 11000401.GPJ US_LAB.GDT 8/24/17

APPENDIX C

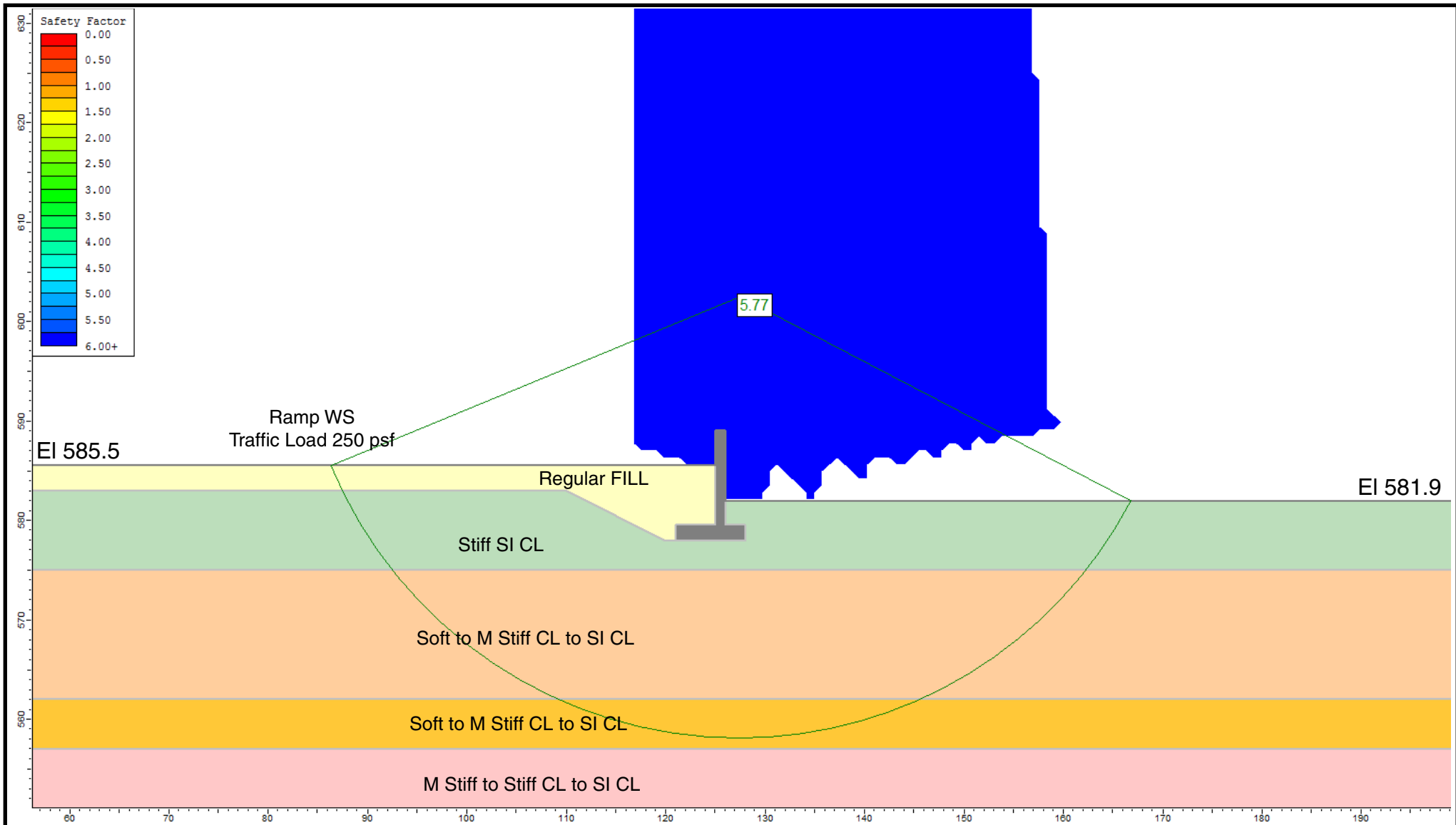

Undrained Analysis for CIP T-type Wall at Station 1231+81.19, Ref Borings 14-RWB-03 and VST-01

Layer ID	Description	Unit Weight (pcf)	Undrained Cohesion (psf)	Undrained Friction Angle (degrees)
1	Regular Granular FILL	125	0	32
2	Stiff SI CL	120	1300	0
3	Soft to M Stiff CLAY to SILTY CLAY	110	650	0
4	Soft to M Stiff CLAY to SILTY CLAY	110	600	0
5	M Stiff to Stiff CL to SI CL	115	1050	0

GLOBAL STABILITY ANALYSIS: CIRCLE INTERCHANGE RECONSTRUCTION, RETAINING WALL 14, SN 016-1803, COOK COUNTY

SCALE: GRAPHICAL | APPENDIX C-1 | DRAWN BY: H. Bista
CHECKED BY: M. Seyhun

 **Wang Engineering**
1145 N. Main Street
Lombard, IL 60148
www.wangeng.com

FOR AECOM | 1100-04-01

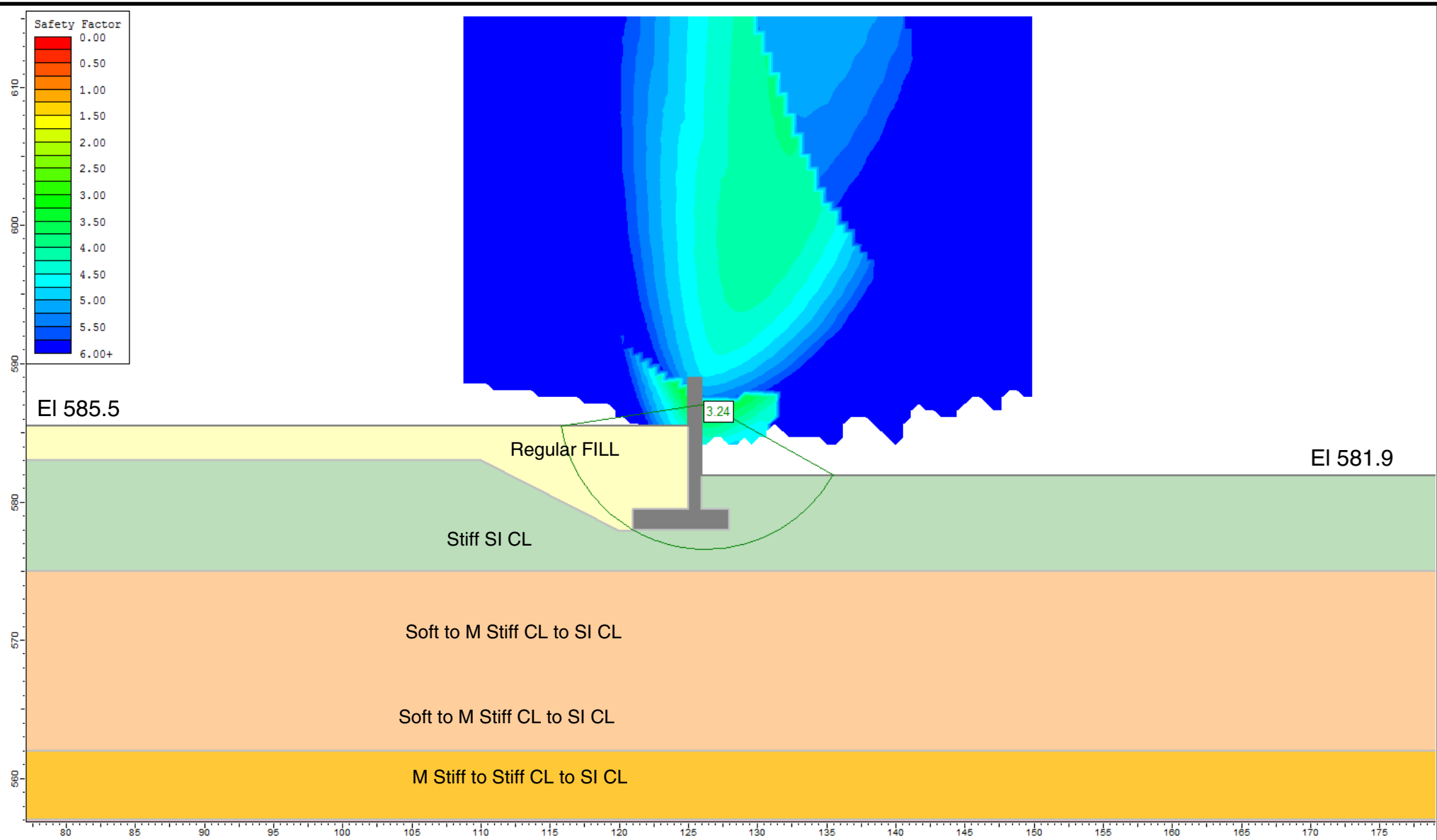

Drained Analysis for CIP T-type Wall at Station 1231+81.19, Ref Borings 14-RWB-03 and VST-01

Layer ID	Description	Unit Weight (pcf)	Drained Cohesion (psf)	Drained Friction Angle (degrees)
1	Regular Granular FILL	125	0	32
2	Stiff SI CL	120	100	30
3	Soft to M Stiff CLAY to SILTY CLAY	110	0	30
4	Soft to M Stiff CLAY to SILTY CLAY	110	0	30
5	M Stiff to Stiff CL to SI CL	115	50	30

GLOBAL STABILITY ANALYSIS: CIRCLE INTERCHANGE RECONSTRUCTION, RETAINING WALL 14, SN 016-1803, COOK COUNTY

SCALE: GRAPHICAL | APPENDIX C-2 | DRAWN BY: H. Bista | CHECKED BY: M. Seyhun



FOR AECOM | 1100-04-01

APPENDIX D

Bench Mark: Chisel "X" on chain bolt of fire hydrant in front of 555 W. Harrison St. Elev. 594.46.

Existing Structure: None.

The existing Ramp WS Bridge (S.N. 016-1715) will be closed and traffic will be detoured during construction. Traffic on I-290 and I-90/94 will be maintained with stage construction.

No Salvage.

NOTES:

1. Wall offsets are measured from the \square of Ramp WS to the front face of panels.
2. F.F. denotes Front Face.
3. B.F. denotes Back Face.
4. All proposed drainage structure locations along I-90/94 are conceptual at this stage and are subject to refinement during final design.
5. Soldier Pile section, shaft diameter, spacing and tip elevation to be determined during final design.

DESIGN SPECIFICATIONS

2014 AASHTO LRFD Bridge Design Specifications 7th Edition with 2015 and 2016 Interim Specifications

DESIGN STRESSES

FIELD UNITS

$f'_c = 3,500$ psi
 $f_y = 60,000$ psi (Reinforcement)

PRECAST UNITS

$f'_c = 4,500$ psi

SOLDIER PILES

$f_y = 50,000$ psi (AASHTO M270 Gr. 50)

WALL DEFLECTION CRITERIA:

Maximum total lateral wall deflection at top of wall: 1 inch.

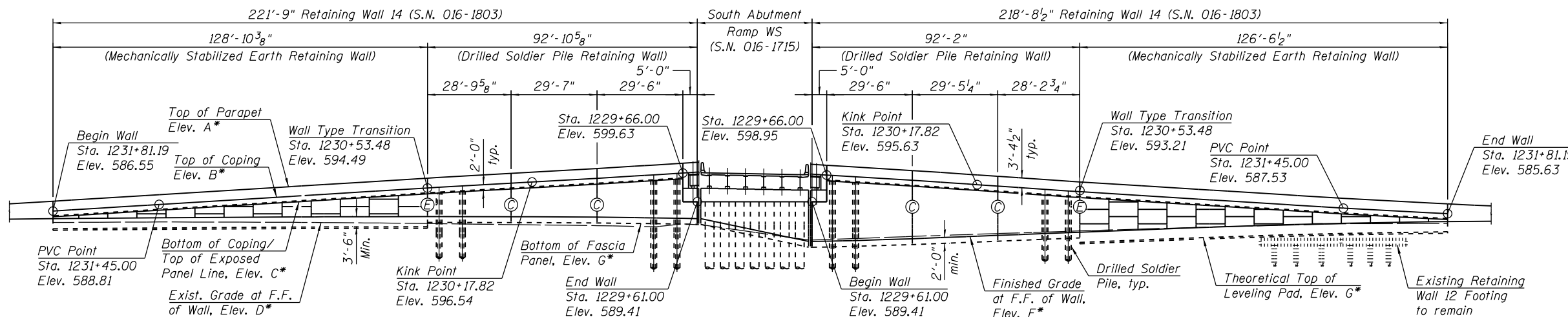

ELEVATION

(Looking at F.F. of Wall, Proposed Concrete Barrier Not Shown for Clarity)

* For elevations, see Table 1 on sheet 2 of 3.

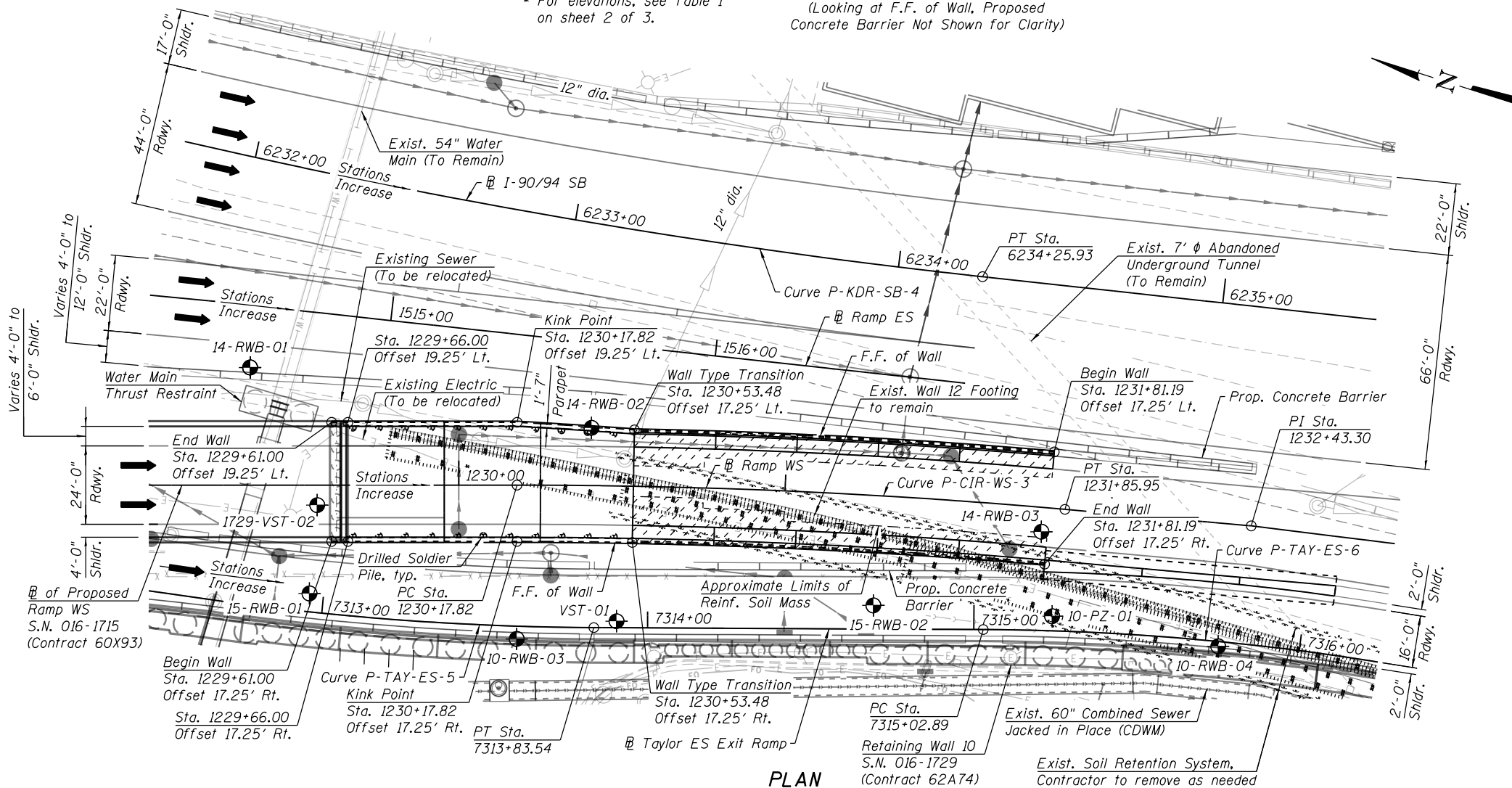

PLAN

LEGEND

- Electric: E
- Water: W
- Exist. Storm Sewer: \rightarrow
- Prop. Storm Sewer: \rightarrow
- Combined Sewer: \rightarrow
- Prop. Catch Basin: \bullet
- Light Pole: \odot
- Soil Boring: \oplus
- Construction Joint: \odot
- Expansion Joint: \ominus
- Limits of Soil Reinforcement: \square

LOCATION SKETCH

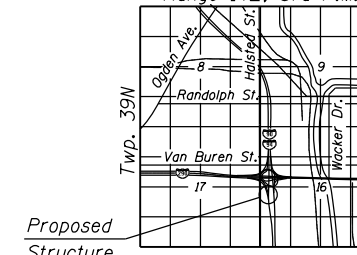

GENERAL PLAN
RETAINING WALL 14 ALONG RAMP WS
F.A.I 94 (I-290 WB TO I-90/94 SB)
SECTION 2014-013 R&B-R
COOK COUNTY
STATION 1229+61.00 TO STATION 1231+81.19
STRUCTURE NO. 016-1803



USER NAME = jrmickens	DESIGNED - JM	REVISED -
PLOT SCALE = 42.666667' / in.	CHECKED - WJC	REVISED -
PLOT DATE = 4/10/2018	DRAWN - JM	REVISED -
	CHECKED - WJC	REVISED -

STATE OF ILLINOIS
DEPARTMENT OF TRANSPORTATION

SHEET NO. 1 OF 3 SHEETS

F.A.I. RTE.	SECTION	COUNTY	TOTAL SHEETS	SHEET NO.
90/94/290	2014-013 R&B-R	COOK	3	1
CONTRACT NO.			60X93	
ILLINOIS FED. AID PROJECT				

2:15:30 PM PW \\617479-PWINT-AECOM\LOCAL-AECOM\DS02-NA\DOCUMENTS\NOI-AMERICAS\TRANSPORTATION\60269938-CIRCLE-1\PHASE-1\1000-CAD\008-STRUCTURAL\STRUCTURE_016-1803-TSL\SHEETS\016-1803-60X93-SHT-TSL-002

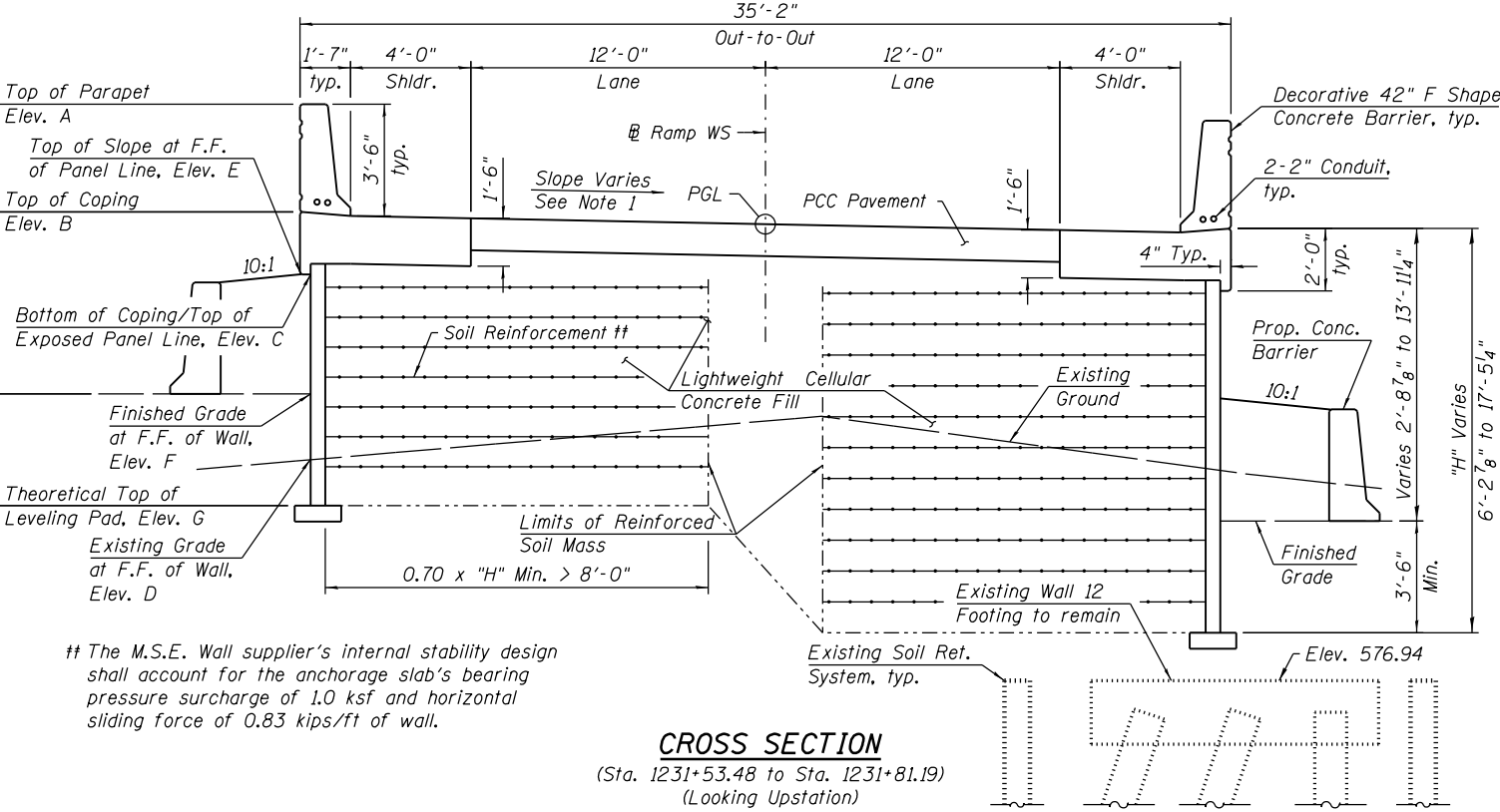
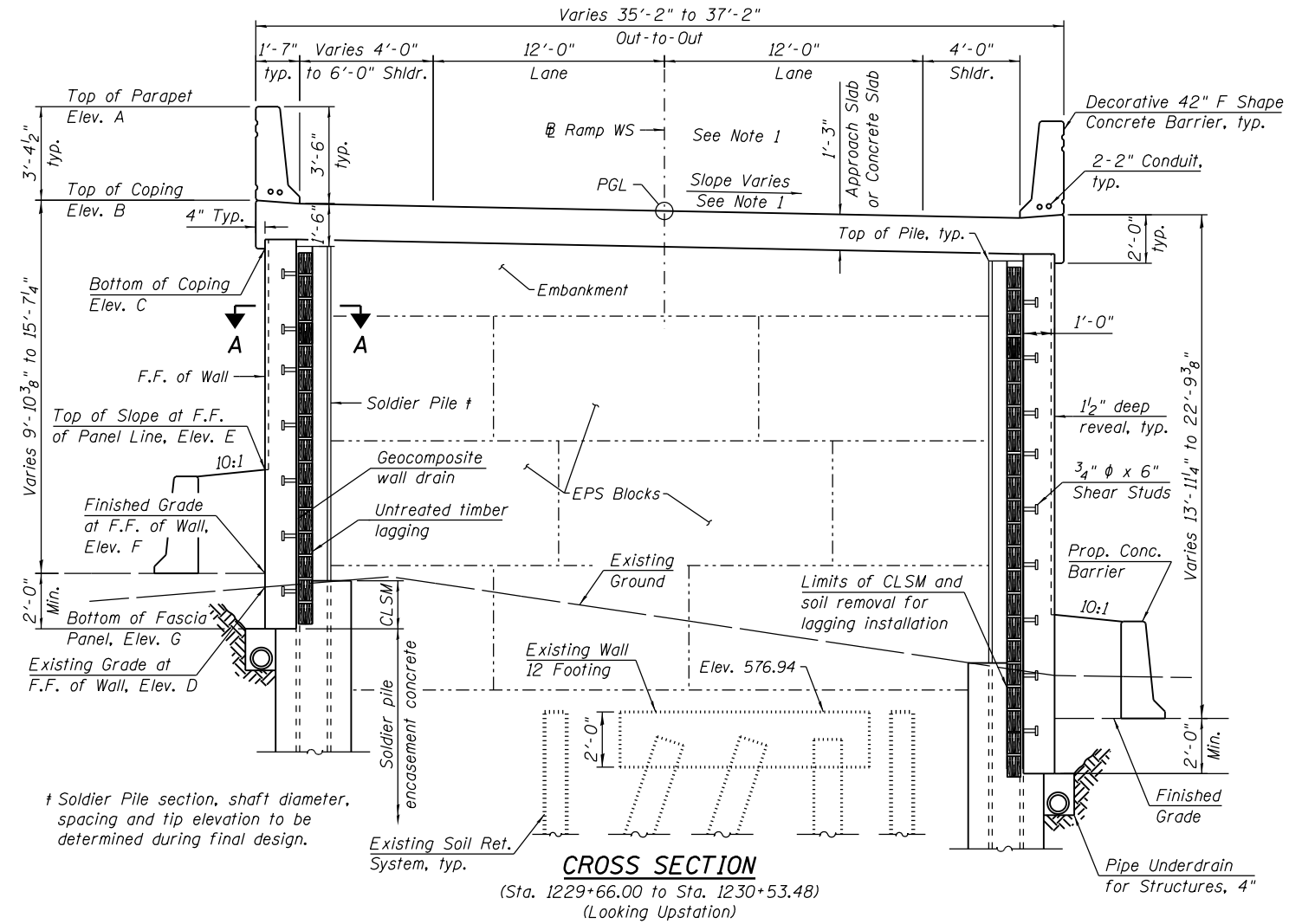

TABLE 1 - MSE WALL ELEVATIONS

Station	Offset	Elevation A	Elevation B	Elevation C	Elevation D	Elevation E	Elevation F	Elevation G	Wall Type
1231+81.19	17.25' Lt.	589.92	586.55	584.55	582.60	587.41	583.99	580.41	MSE Wall
1231+75.00	17.25' Lt.	590.30	586.93	584.93	582.64	587.49	583.99	580.49	
1231+45.00	17.25' Lt.	592.19	588.81	586.81	582.78	587.98	584.23	580.73	
1231+25.00	17.25' Lt.	593.43	590.05	588.05	582.75	588.21	584.36	580.86	
1231+00.00	17.25' Lt.	594.98	591.60	589.60	582.68	588.52	584.51	581.01	MSE Wall
1230+75.00	17.25' Lt.	596.53	593.15	591.15	582.47	588.78	584.60	581.10	
1230+53.48	17.25' Lt.	597.86	594.49	592.49	582.24	588.98	584.62	581.12	
1230+50.00	17.44' Lt.	598.09	594.71	592.71	582.19	588.99	584.62	581.12	
1230+25.00	18.85' Lt.	599.51	596.14	594.14	581.87	588.98	584.57	581.12	Drilled Shafts Wall
1230+17.82	19.25' Lt.	599.91	596.54	594.54	581.79	588.95	584.55	581.12	
1229+95.50	19.25' Lt.	601.18	597.80	595.80	581.51	588.97	584.45	581.12	
1229+75.00	19.25' Lt.	602.45	599.07	597.07	581.13	588.83	584.19	581.12	
1229+66.00	19.25' Lt.	603.01	599.63	597.63	582.13	588.72	584.03	581.12	Drilled Shafts Wall
1229+61.00	19.25' Lt.	-	-	589.41	581.87	588.66	583.94	581.12	
1229+61.00	17.25' Rt.	-	-	589.41	576.55	579.84	576.08	574.08	
1229+66.00	17.25' Rt.	602.33	598.95	596.95	576.74	579.98	576.17	574.17	
1229+75.00	17.25' Rt.	601.77	598.39	596.39	577.05	580.24	576.35	574.35	Drilled Shafts Wall
1229+95.50	17.25' Rt.	600.50	597.12	595.12	577.80	581.03	576.99	574.99	
1230+17.82	17.25' Rt.	599.01	595.63	593.63	578.56	582.02	577.88	575.88	
1230+25.00	17.25' Rt.	598.51	595.14	593.14	578.79	582.32	578.16	576.16	
1230+50.00	17.25' Rt.	596.80	593.42	591.42	579.58	583.30	579.14	577.14	MSE Wall
1230+53.48	17.25' Rt.	596.58	593.21	591.21	579.72	583.42	579.27	577.27	
1230+75.00	17.25' Rt.	595.25	591.87	589.87	580.35	584.20	580.09	576.59	
1231+00.00	17.25' Rt.	593.70	590.32	588.32	581.06	585.07	581.04	577.54	
1231+25.00	17.25' Rt.	592.15	588.77	586.77	581.66	585.76	581.84	578.34	MSE Wall
1231+45.00	17.25' Rt.	590.91	587.53	585.53	582.17	586.15	582.33	578.83	
1231+75.00	17.25' Rt.	589.29	585.92	583.92	582.27	586.44	582.83	579.33	
1231+81.19	17.25' Rt.	589.00	585.63	583.63	582.29	586.47	582.89	579.39	

Elevation A - Top of Parapet
 Elevation B - Top of Coping
 Elevation C - Bottom of Coping / Top of Exposed Panel Line
 Elevation D - Existing Grade at F.F. of Wall
 Elevation E - Top of Slope at F.F. of Wall
 Elevation F - Finished Grade at F.F. of Wall
 Elevation G - Theoretical Top of Leveling Pad / Bottom of Fascia Panel

* Elevations just to the left of joint
 ** Elevations just to the right of joint

CURVE DATA
(Taylor ES Exit Ramp)

P-TAY-ES-5 P.I. Sta. = 7313+24.65 Δ = 7° 47' 11" (LT) D = 6° 36' 03" R = 868.00' T = 59.07' L = 117.96' E = 2.01' e = 4.40% T.R. = NA' S.E. Run = 114' P.C. Sta. = 7312+65.57 P.T. Sta. = 7313+83.54	P-TAY-ES-6 P.I. Sta. = 7315+63.15 Δ = 8° 44' 46" (RT) D = 7° 16' 16" R = 788.00' T = 60.26' L = 120.29' E = 2.30' e = 4.60% T.R. = NA' S.E. Run = 119' P.C. Sta. = 7315+02.89 P.T. Sta. = 7316+23.18
--	--

CURVE DATA
(Ramp WS)

P-CIR-WS-3 P.I. Sta. = 1231+01.94 Δ = 5° 04' 12" (RT) D = 3° 00' 56" R = 1,900.00' T = 84.12' L = 168.13' E = 1.86' e = 4.00% T.R. = NA' S.E. Run = 44' P.C. Sta. = 1230+17.82 P.T. Sta. = 1231+85.95

CURVE DATA
(I-90/94 SB)

P-KDR-SB-4 P.I. Sta. = 6231+84.46 Δ = 13° 18' 21" (LT) D = 2° 44' 34" R = 2,089.00' T = 243.66' L = 485.13' E = 14.16' e = 4.40% T.R. = NA' S.E. Run = 164' P.C. Sta. = 6229+40.80 P.T. Sta. = 6234+25.93

NOTES:

- Direction of slope referenced from right edge of pavement.
 Constant Cross Slope (2.00%) Sta. 1226+31.89 to Sta. 1230+03.45
 Slope Transition (2.00% to 4.00%) Sta. 1230+03.45 to Sta. 1230+47.45
 Constant Cross Slope (4.00%) Sta. 1230+47.45 to Sta. 1231+56.32
 Slope Transition (4.00% to 2.00%) Sta. 1231+56.32 to Sta. 1232+00.32
 Constant Cross Slope (2.00%) Sta. 1232+00.32 to Sta. 1233+72.63
- The overlapping sections of the MSE wall with the abandoned wall footing will require special MSE wall installation and design to ensure that excessive differential settlement between the MSE wall and the rigid existing footing supported on deep foundations are minimized.

CROSS SECTIONS
RETAINING WALL 14 ALONG RAMP WS
F.A.I. 94 (I-290 WB TO I-90/94 SB)
SECTION 2014-013 R&B-R
COOK COUNTY
STATION 1229+61.00 TO STATION 1231+81.19
STRUCTURE NO. 016-1803



USER NAME = jrmickens	DESIGNED - JM	REVISSED -
PLOT SCALE = 6.0000' / in.	CHECKED - WJC	REVISSED -
PLOT DATE = 4/10/2018	DRAWN - JM	REVISSED -
	CHECKED - WJC	REVISSED -

STATE OF ILLINOIS
DEPARTMENT OF TRANSPORTATION

F.A.I. RTE.	SECTION	COUNTY	TOTAL SHEETS	SHEET NO.
90/94/290	2014-013 R&B-R	COOK	3	2
CONTRACT NO.			60X93	
ILLINOIS FED. AID PROJECT				

2:14:52 PM PW \\617479-PWINT-AECOM\LINE.LOCAL-AECOM.DS02_NA\DOCUMENTS\NOI-AMERICAS\TRANSPORTATION\60269938-CIRCLE\PHASE-1\1000-CAD\008-STRUCTURAL\STRUCTURE_016-1803-TSL\SHEETS\016-1803-60X93-SHT-TSL-003

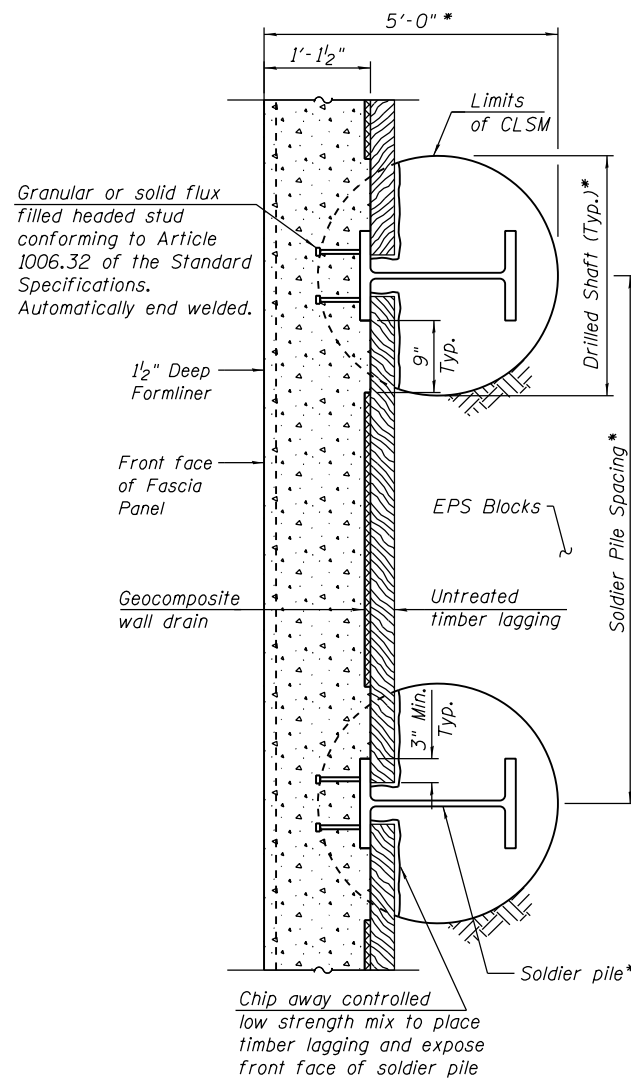

SECTION A-A

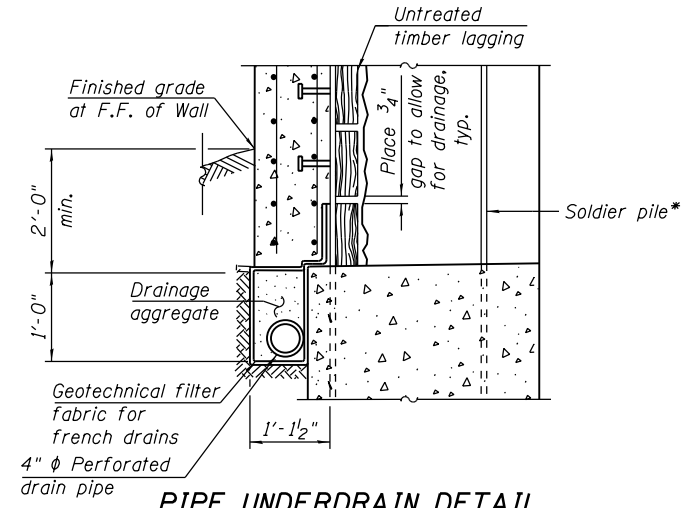

PIPE UNDERDRAIN DETAIL AT SOLDIER PILE

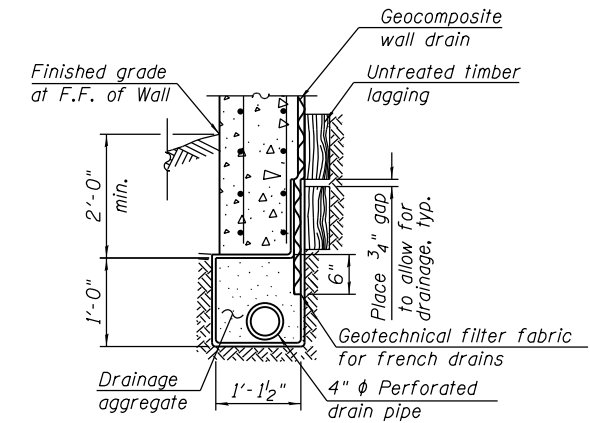

PIPE UNDERDRAIN DETAIL BETWEEN SOLDIER PILES

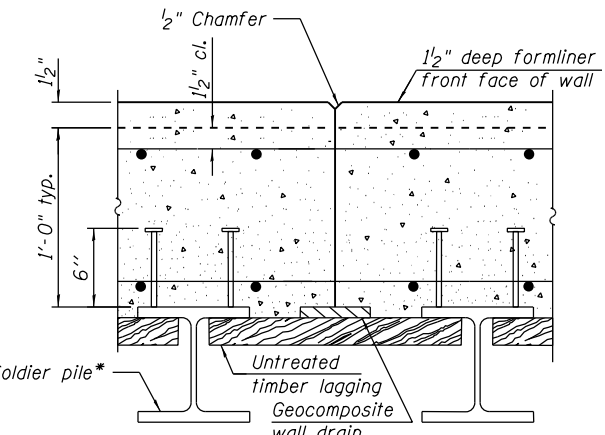

CONSTRUCTION JOINT DETAILS

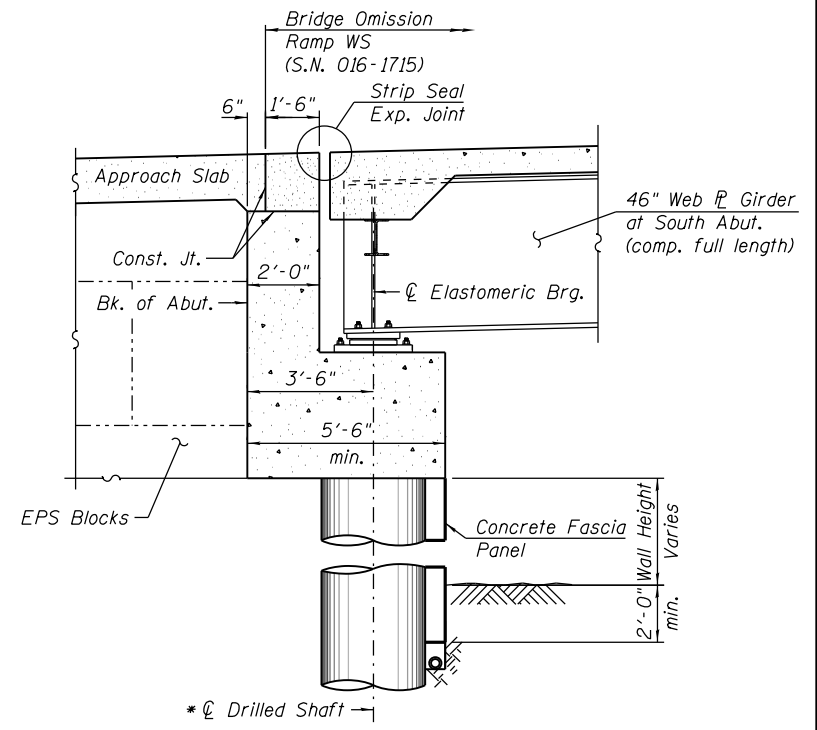

SECTION THRU ABUTMENT

* Size, spacing, depth and number to be determined in design.

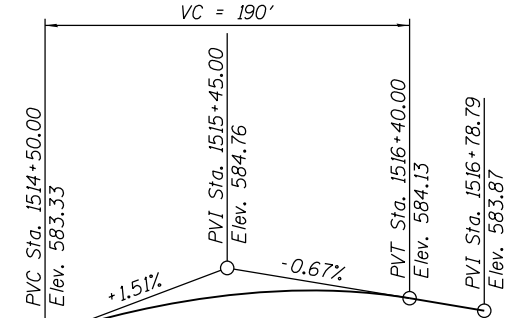

PROFILE GRADE
(Along Ramp ES)

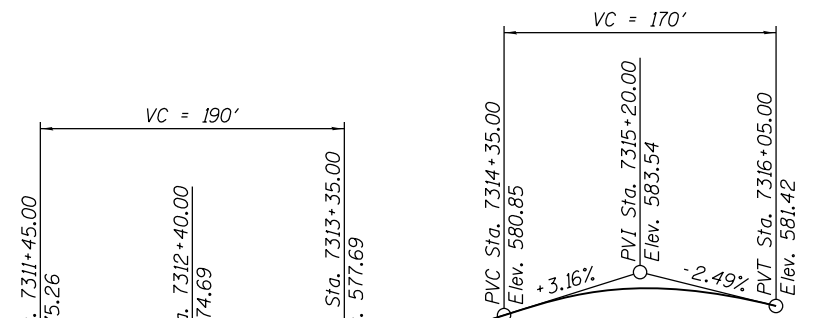

PROFILE GRADE
(Along Taylor ES Exit Ramp)

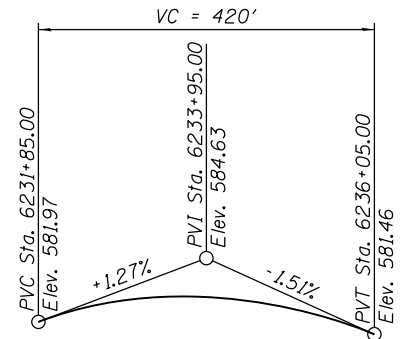

PROFILE GRADE
(Along SB I-90/94)

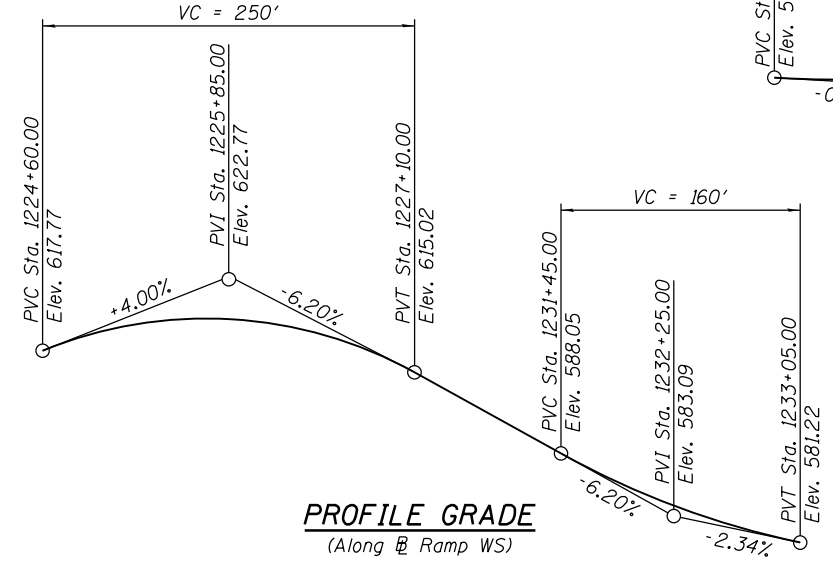

PROFILE GRADE
(Along Ramp WS)

HIGHWAY CLASSIFICATION

Ramp WS	SB I-90/94
Functional Class: Interstate	Functional Class: Interstate
ADT: 7,200 (2012); 8,000 (2040)	ADT: 100,100 (2012); 98,000 (2040)
ADTT: 114 (2012); 127 (2040)	ADTT: 11,351 (2012); 11,113 (2040)
DHV: 710 (2040)	DHV: 6,340 (2040)
Design Speed: 25 m.p.h.	Design Speed: 60 m.p.h.
Posted Speed: 25 m.p.h.	Posted Speed: 45 m.p.h.
One-Way Traffic	One-Way Traffic
Directional Distribution: 100%	Directional Distribution: 100%
Ramp ES	Taylor ES Exit Ramp
Functional Class: Interstate	Functional Class: Interstate
ADT: 43,900 (2012); 43,000 (2040)	ADT: NA (2012); 2,000 (2040)
ADTT: 4,386 (2012); 4,296 (2040)	ADTT: NA (2012); 60 (2040)
DHV: 2,060 (2040)	DHV: 150 (2040)
Design Speed: 40 m.p.h.	Design Speed: 35 m.p.h.
Posted Speed: 40 m.p.h.	Posted Speed: NA m.p.h.
One-Way Traffic	One-Way Traffic
Directional Distribution: 100%	Directional Distribution: 100%

DETAILS
RETAINING WALL 14 ALONG RAMP WS
F.A.I. 94 (I-290 WB TO I-90/94 SB)
SECTION 2014-013 R&B-R
COOK COUNTY
STATION 1229+61.00 TO STATION 1231+81.19
STRUCTURE NO. 016-1803



USER NAME = jrmickens	DESIGNED - JM	REVISED -
PLOT SCALE = 6.0000' / 1"	CHECKED - WJC	REVISED -
PLOT DATE = 4/10/2018	DRAWN - JM	REVISED -
	CHECKED - WJC	REVISED -

STATE OF ILLINOIS
DEPARTMENT OF TRANSPORTATION

SHEET NO. 3 OF 3 SHEETS

F.A.I. RTE. 90/94/290	SECTION 2014-013 R&B-R	COUNTY COOK	TOTAL SHEETS 3	SHEET NO. 3
CONTRACT NO. 60X93			ILLINOIS FED. AID PROJECT	