

|                     |            |          |                  |           |
|---------------------|------------|----------|------------------|-----------|
| FAP NO.             | SECTION    | COUNTY   | TOTAL SHEETS     | SHEET NO. |
| 338                 | 114 BY-R-1 | WILL     | 139              | 80        |
| STA.                |            | TO STA.  |                  |           |
| FED. ROAD DIST. NO. |            | ILLINOIS | FED. AID PROJECT |           |

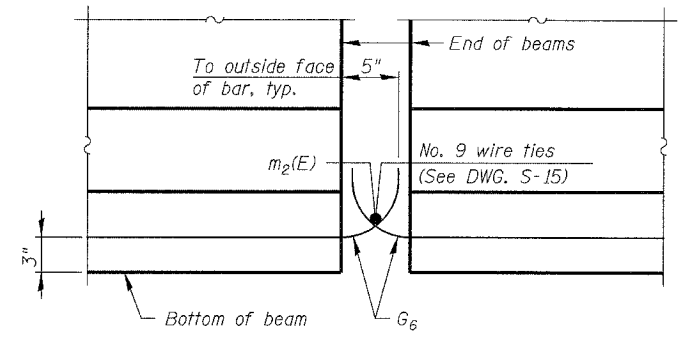

**ELEVATION OF BEAM AT PIER**

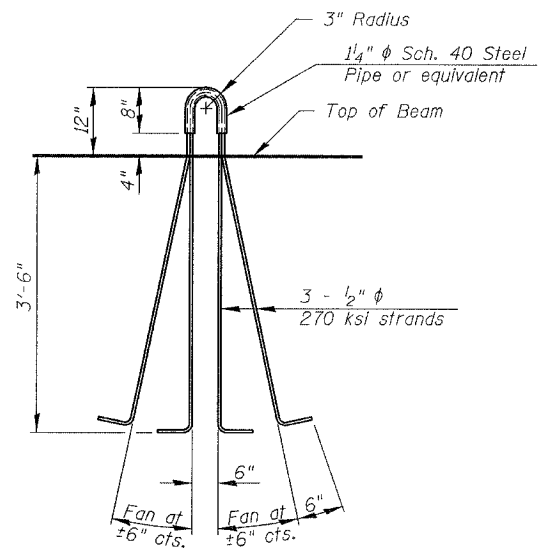

**LIFTING LOOP DETAIL**

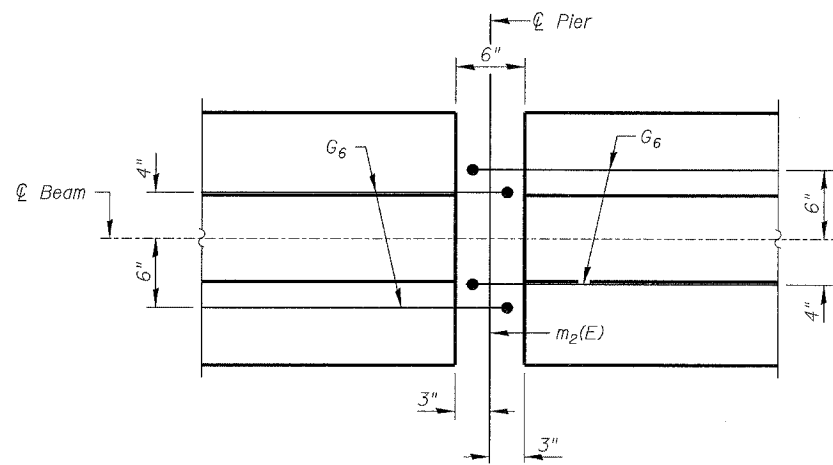

**PLAN OF BEAM AT PIER**

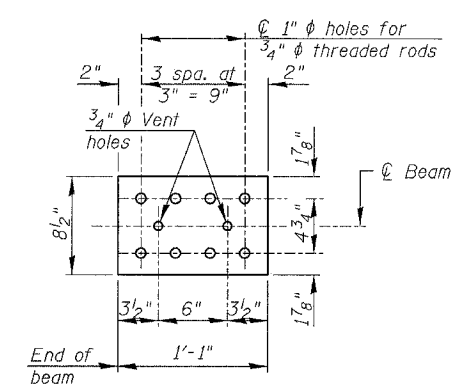

**TOP PLATE**

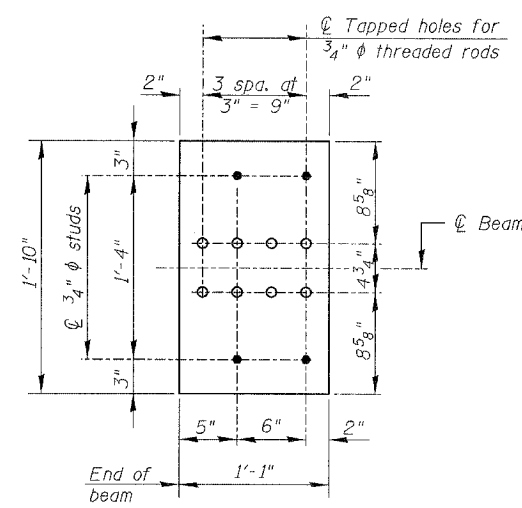

**BOTTOM PLATE**

See bearing details for pintle hole locations when required.

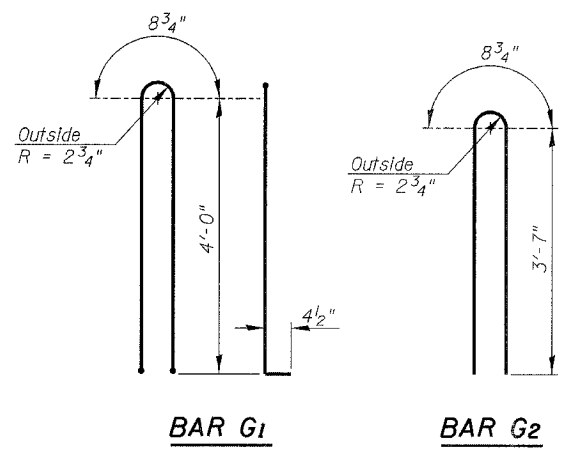

**BAR G1**

**BAR G2**

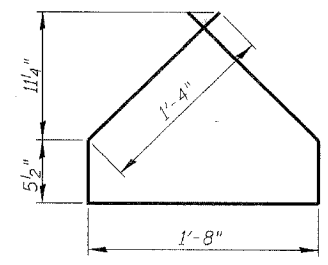

**BAR G4**

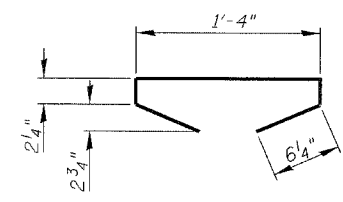

**BAR G5**

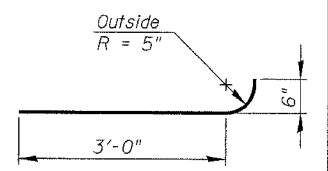

**BAR G6**

**NOTES**

Inserts for 3/4"  $\phi$  threaded dowel rods, when specified, are to be two strut, coil type for interior beams and single coil, flared loop type for exterior beams.  
 Prestressing steel shall be uncoated high strength, low relaxation 7-wire strand, Grade 270.  
 The nominal diameter shall be 1/2" and the nominal cross-sectional area shall be 0.153 sq. in.  
 Non-prestressing steel shall conform to AASHTO designation M-31 or M 322, Grade 60.  
 A minimum 2 1/2"  $\phi$  lifting pin shall be used to engage the lifting loops during handling.  
 Reinforcement bars designated (E) shall be epoxy coated.  
 Cut G6 bars when necessary to maintain 1/2" clearance.  
 The bottom plates and studs shall be galvanized according to AASHTO M11.  
 Threaded rods shall be ASTM F 1554 Grade 55.  
 The cut strands at each beam end shall be given two coats of zinc dust spray or paint meeting the requirements of ASTM A 780. The zinc dust spray or paint shall be applied before corrosion appears and allowed to dry according to the manufacturer's specifications prior to another coat of zinc. A concrete sealer meeting the requirements of Section 587 of the Standard Specifications shall be applied to all portions of the I-beam or Bulb-T beam, except the top surface of the top flange and the bottom surface of the bottom flange, starting at each beam end and extending out a distance of 48 inches. The sealer shall be applied after visible crack growth has subsided. This work shall be performed by the producer and included with the cost of the beam.

**BILL OF MATERIAL**

| Item  | Unit | Total |
|---|------|-------|
| Erecting Precast Prestressed Concrete I-Beams, 48 IN. | Foot | 2880  |

DWG. S-21 of 34

| REVISIONS |      | ILLINOIS DEPARTMENT OF TRANSPORTATION<br><b>48" PPC I-BEAM DETAILS</b><br>ILLINOIS ROUTE 59 OVER DuPAGE RIVER<br>FAP ROUTE 338 SECTION 114 BY-R-1<br>WILL COUNTY<br>STATION 3209+85.00<br>STRUCTURE NUMBER 099-0339 |
|-----------|------|---|
| NAME      | DATE |   |
|           |      | SCALE: NONE<br>DATE: 08/17/07   |
|           |      | DESIGNED BY: SB<br>CHECKED BY: WPM  |
|           |      | DRAWN BY: TL<br>CHECKED BY: SB  |

FILE: L:\6632\01\Cad\Sheets\Roadway\_Structures\Bridges\663201-50339-BM03.dgn