

F.A.U. RTE.	SECTION	COUNTY	TOTAL SHEETS	SHEET NO.
2678	N-7-5-I-1	COOK	18	10
STA.		TO STA.		
FED. ROAD DIST. NO.	ILLINOIS	FED. AID PROJECT		

**CONTRACT NO. 60C45**

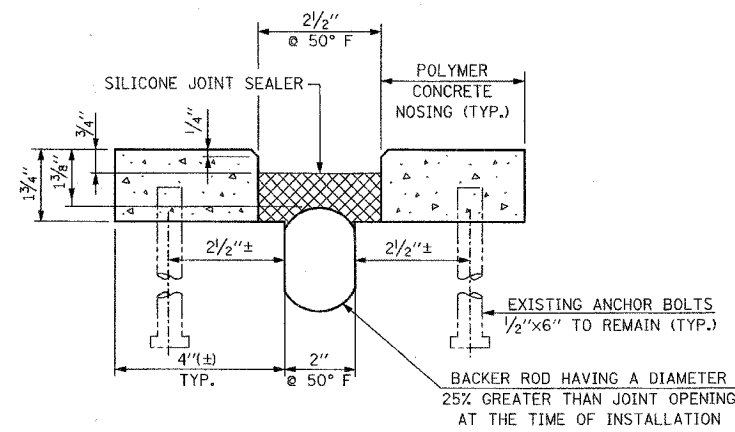

**NOTES:**

1. PLAN DIMENSIONS AND DETAILS RELATIVE TO EXISTING PLANS ARE SUBJECT TO ROUTINE VARIATIONS. THE CONTRACTOR SHALL FIELD VERIFY EXISTING DIMENSIONS AND DETAILS AFFECTING NEW CONSTRUCTION AND MAKE NECESSARY APPROVED ADJUSTMENTS PRIOR TO CONSTRUCTION OR ORDERING OF MATERIALS. SUCH VARIATIONS SHALL NOT BE CAUSE FOR ADDITIONAL COMPENSATION FOR A CHANGE IN SCOPE OF THE WORK, HOWEVER, THE CONTRACTOR WILL BE PAID FOR THE QUANTITY ACTUALLY FURNISHED BASED UPON THE UNIT PRICE BID FOR THE WORK.
2. COST FOR REMOVAL OF EXISTING JOINT IS INCLUDED IN THE COST OF SILICONE JOINT SEALER.

**SECTION AT PIER 1 = 40'-6 1/4"**

**SECTION AT PIER 3 = 3'-0"**

(EXISTING NEOPRENE TRANSVERSE EXPANSION JOINT)  
FOR LOCATION SEE DECK CONCRETE PATCHING ON SHEET NO. 4

**BILL OF MATERIAL**

DESCRIPTION	UNIT	QUANTITY
POLYMER CONCRETE	CU. FT.	4.0
SILICONE JOINT SEALER, 2 1/2"	FT.	44

REVISIONS	
NAME	DATE

ILLINOIS DEPARTMENT OF TRANSPORTATION

SILICONE SEAL JOINT REPAIR  
F.A.U. RTE. 2678/ELMHURST ROAD  
OVER  
NORTHWEST TOLLWAY (I-90)  
STRUCTURE NO. 016-0678

SCALE: NONE  
DATE: JULY 25, 2007

DRAWN BY: F.M.  
CHECKED BY: B.N.S.

**CHRISTIAN-ROGE & ASSOC., INC.**  
CHICAGO ILLINOIS