

EROSION CONTROL DETAILS FOR SILT FENCE

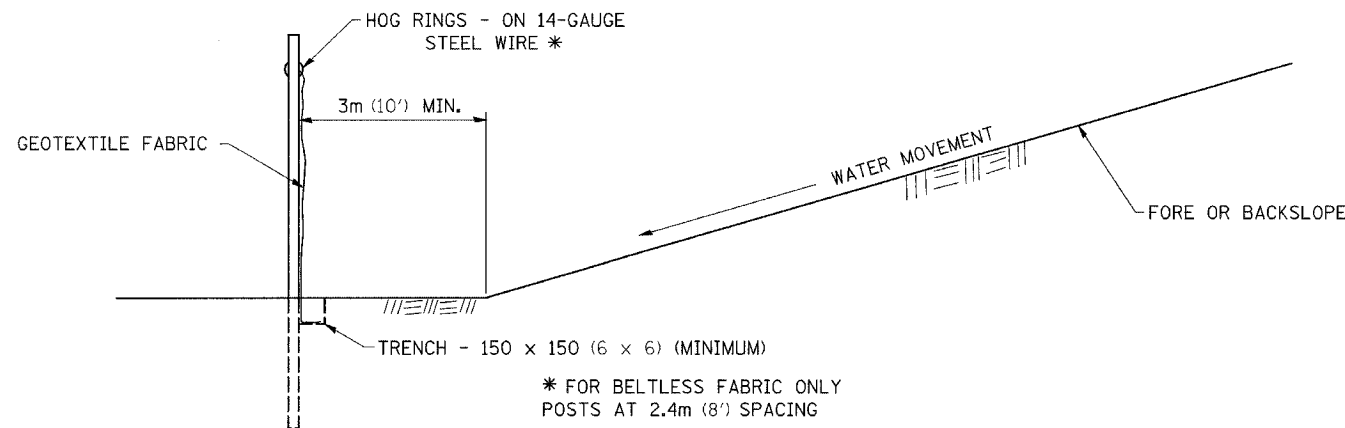
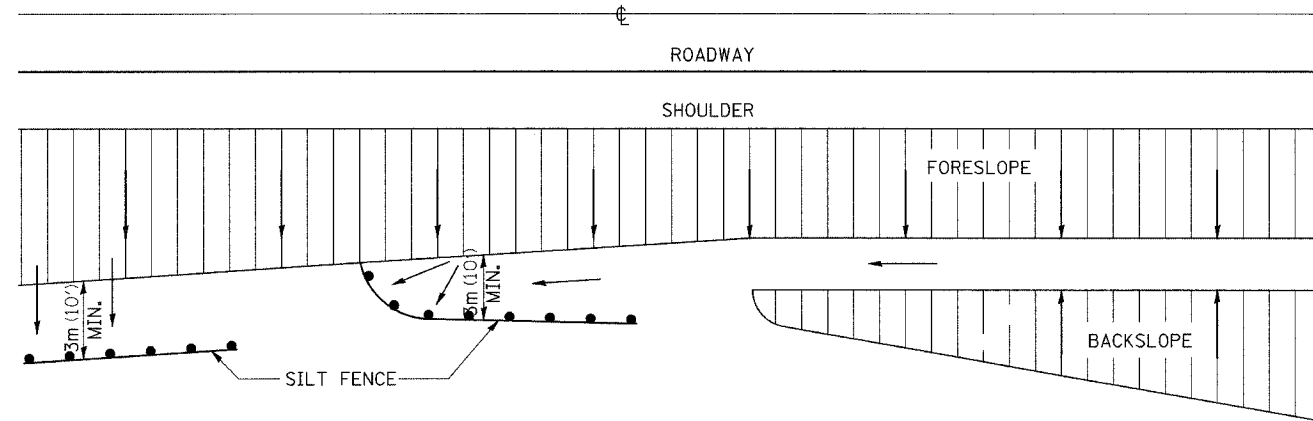

DETAILS OF SILT FENCE

* FOR BELTLESS FABRIC ONLY
POSTS AT 2.4m (8') SPACING

ALL DIMENSIONS ARE IN MILLIMETERS (INCHES) UNLESS OTHERWISE NOTED.

WITNESS MARKER FOR PERMANENT SURVEY MARKERS, TYPE II

CONTRACT NO. 64931			
F.A.P. RTE.	SECTION	COUNTY	TOTAL SHEETS
*595	5HBR	ROCKISLAND	139
NO.	SHEET NO.		
101	101		
STA.	TO STA.		
FED. ROAD DIST. NO.	ILLINOIS	FED. AID PROJECT	
*(IL 5/IL 92)			

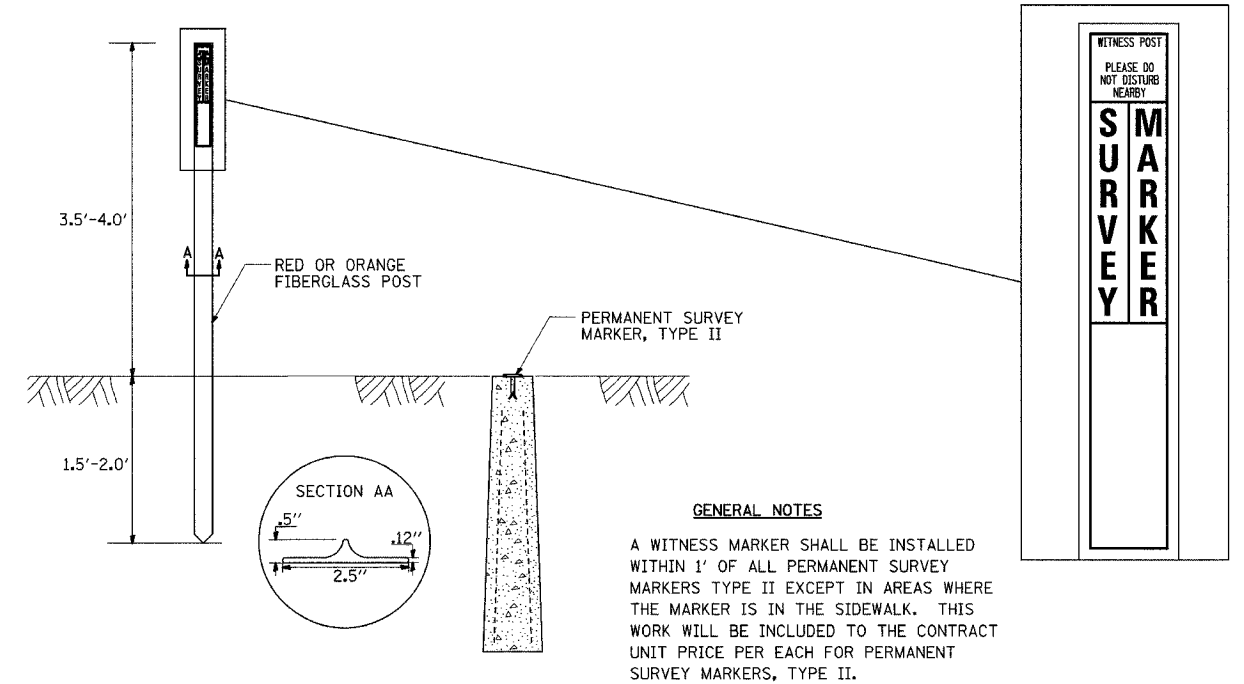

GENERAL NOTES

A WITNESS MARKER SHALL BE INSTALLED WITHIN 1' OF ALL PERMANENT SURVEY MARKERS TYPE II EXCEPT IN AREAS WHERE THE MARKER IS IN THE SIDEWALK. THIS WORK WILL BE INCLUDED TO THE CONTRACT UNIT PRICE PER EACH FOR PERMANENT SURVEY MARKERS, TYPE II.

PERMANENT SURVEY MARKERS, TYPE II

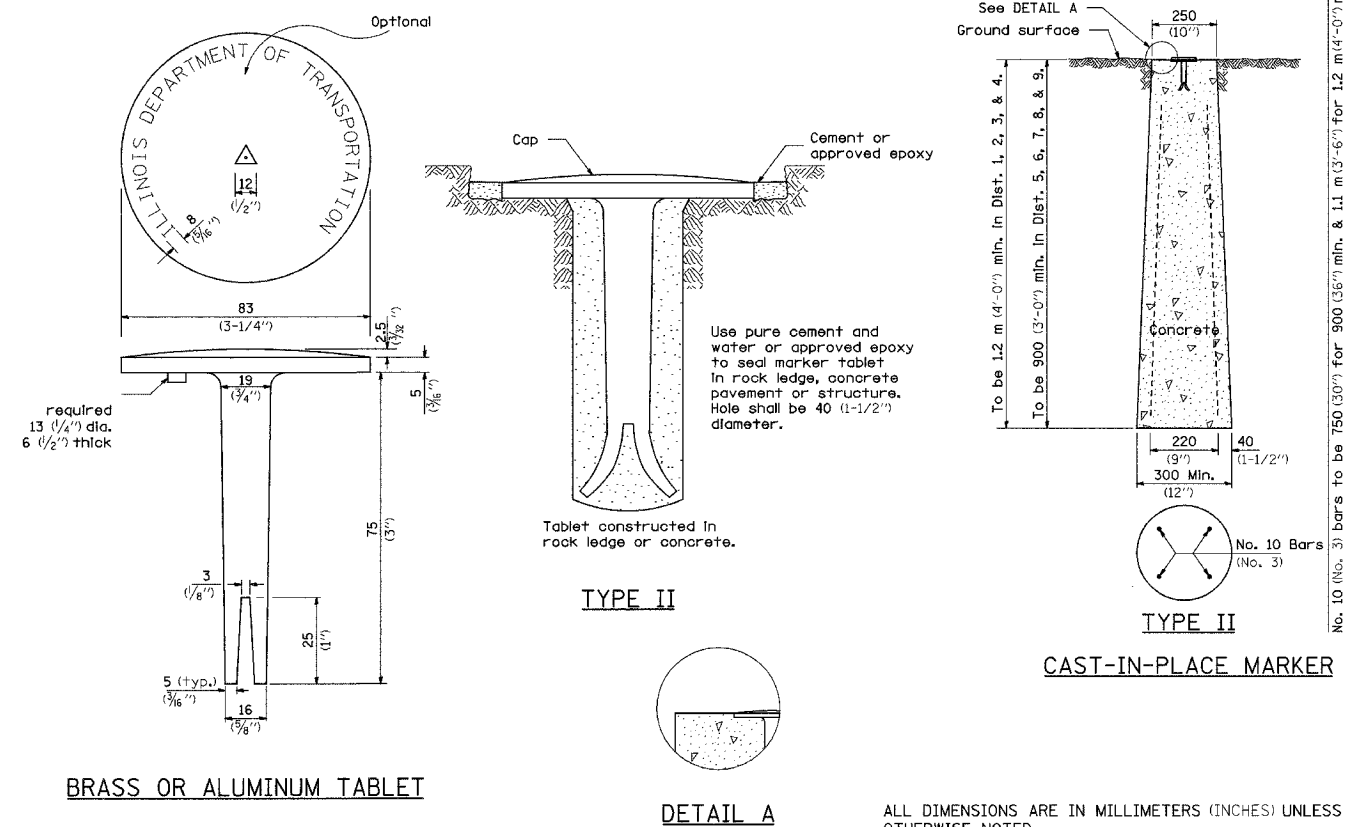

BRASS OR ALUMINUM TABLET

TYPE II

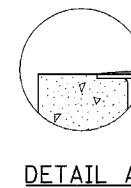

DETAIL A

CAST-IN-PLACE MARKER

ALL DIMENSIONS ARE IN MILLIMETERS (INCHES) UNLESS OTHERWISE NOTED.

PLT DATE = Wed Aug 22 13:42:59 2007
FILE NAME = c:\p\proj\512082831\082831.dwg
USER = jk
PLOT SCALE = 1/1
REFERENCE = REF4