

WING WALL ELEVATION
Showing Dimensions

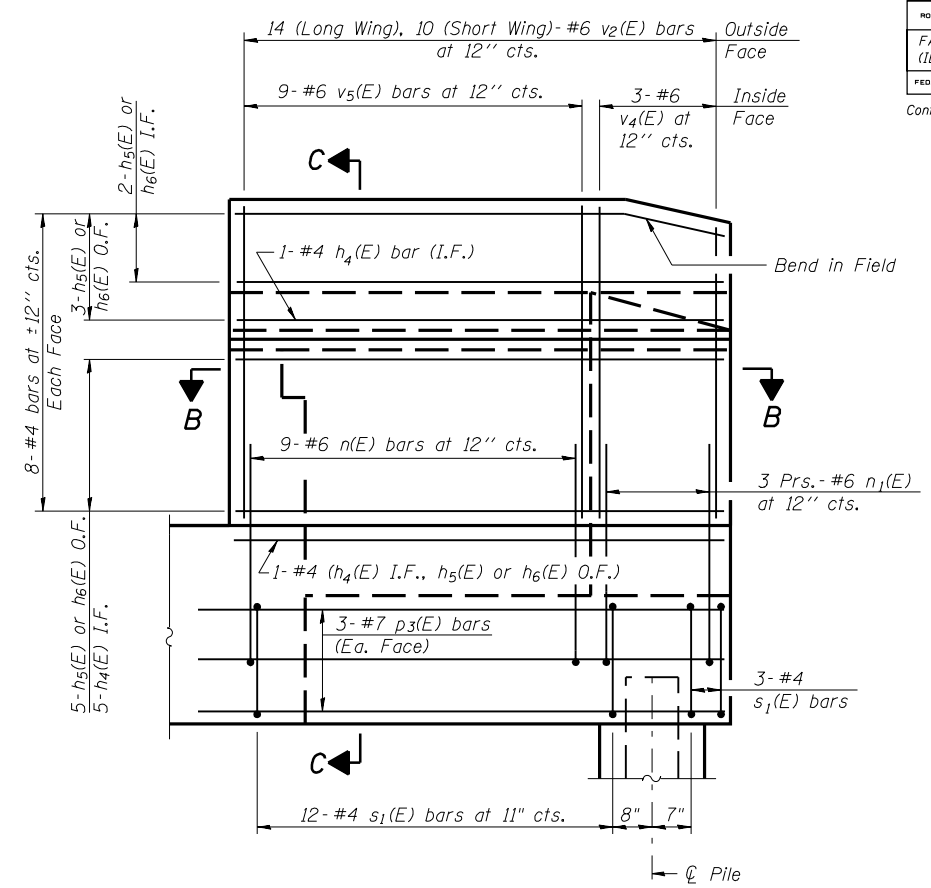

WING WALL ELEVATION
Showing Reinforcement

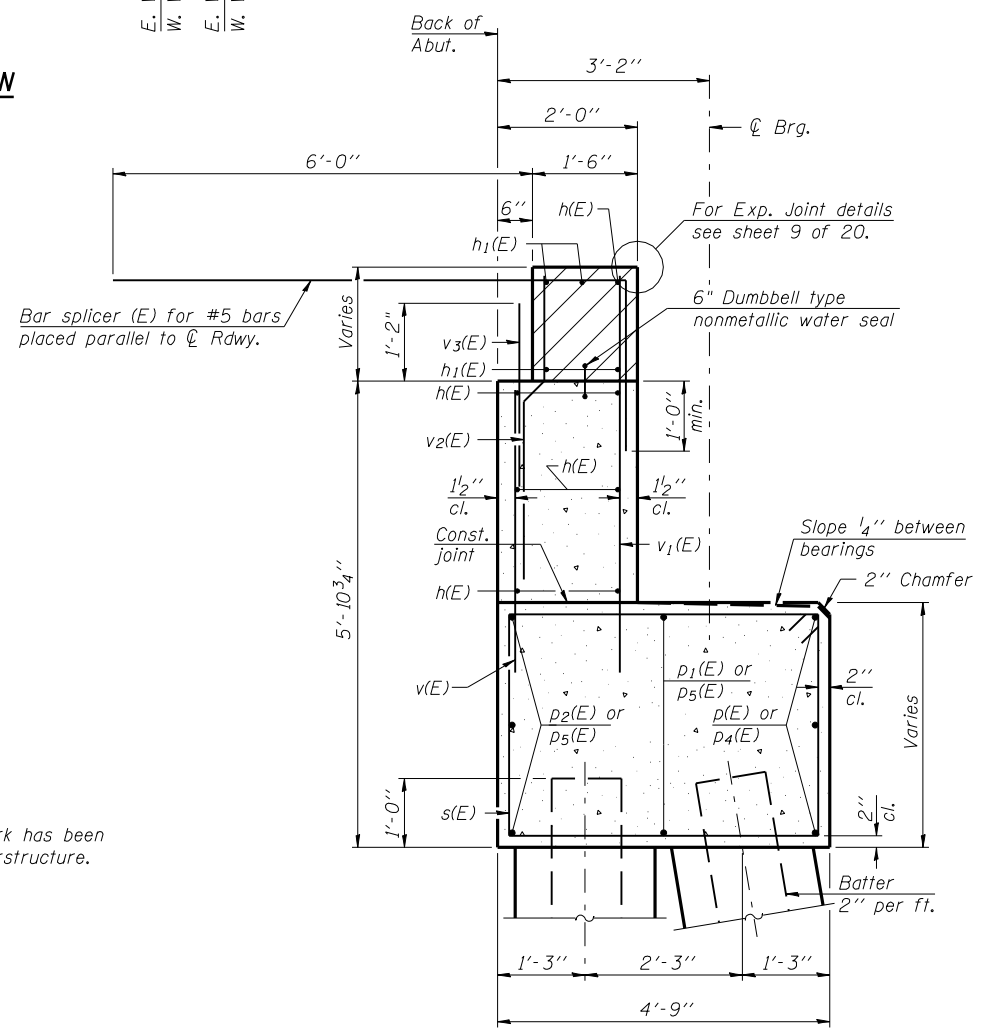

SEC. THRU ABUT.

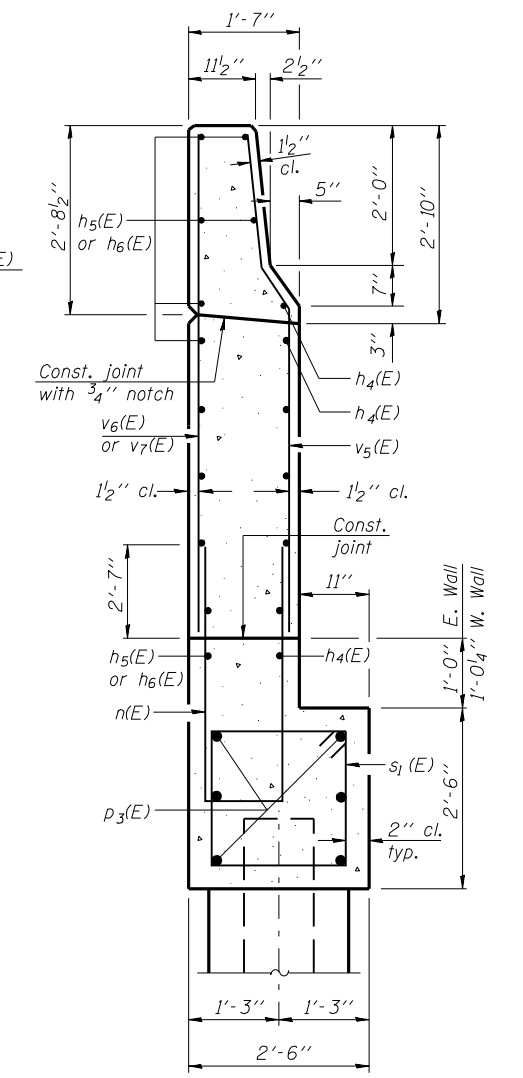

SECTION C-C

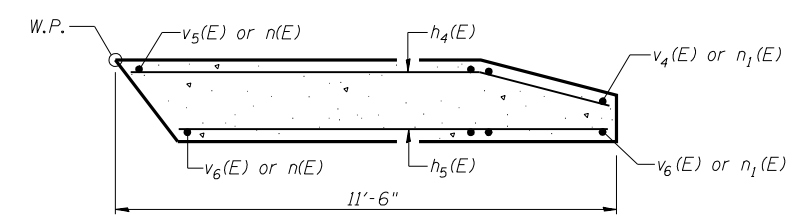

SECTION B-B
(Short wing shown, long wing similar)

Notes:
 Hatched area to be poured after superstructure false work has been removed. Quantity of concrete included with Concrete Superstructure.
 Space reinforcement in cap to miss anchor bolts.
 Pour steps monolithically with cap.
 Quantity of concrete in end post included with Concrete Superstructure on sheet 8 of 20.
 For Concrete Encasement details, see sheet 18 of 20.

REVISIONS

NAME	DATE

Lin Engineering, Ltd.
 Consulting Engineers
 Chatham, Illinois

Designed By: RKM Checked By: MTH Drawn By: AUF
 Date: 04/2007 File: 068-0506.DGN

ILLINOIS DEPARTMENT OF TRANSPORTATION
PILE BENT ABUTMENT DETAILS
 ILLINOIS ROUTE 127 OVER
 BEARCAT CREEK
 F.A.P. ROUTE 42 - SECTION 106 (B-1)
 MONTGOMERY COUNTY
 STA. 126+58.45
 STRUCTURE NO. 068-0506