

| F.A.P. RTE. | SECTION | COUNTY | TOTAL SHEETS | SHEET NO. |
|---------------------|------------|----------|--------------|-----------|
| 304 | 2(B-5,B-6) | PIKE | 112 | 45 |
| STA. | | TO STA. | | |
| FED. ROAD DIST. NO. | | ILLINOIS | | |

LEGEND FOR STORM WATER POLLUTION PREVENTION PLAN

| ITEM | SYMBOL |
|--|----------|
| AGGREGATE (EROSION CONTROL) [STONE DUMPED RIPRAP DITCH CHECKS: Height = 0.6m (2')] | |
| TEMPORARY DITCH CHECKS | |
| INLET PIPE PROTECTION (I&PP) | |
| EROSION CONTROL FENCE | |
| EARTH EXCAVATION FOR EROSION CONTROL (SEDIMENT BASINS) | |
| PRESERVE EXISTING TREES, WOODLANDS, AND UNDERSTORY (OUTSIDE CONSTRUCTION LIMITS) | |
| ITEM PLACED AT BEGINNING OF CONSTRUCTION (Requirement) | * ITEM * |
| ITEM PLACED AS DIRECTED BY ENGINEER (When required by situation) | ITEM |
| DIRECTION OF OVERLAND FLOW | |

GENERAL NOTES:
All items shall be constructed as shown on this sheet, on Standard 280001, and as directed by the Engineer.

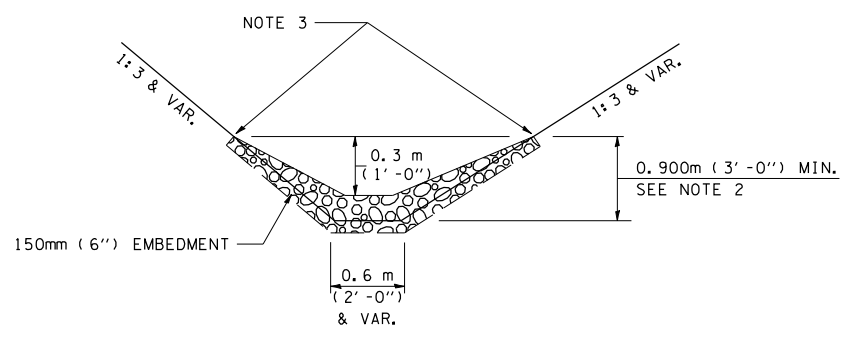
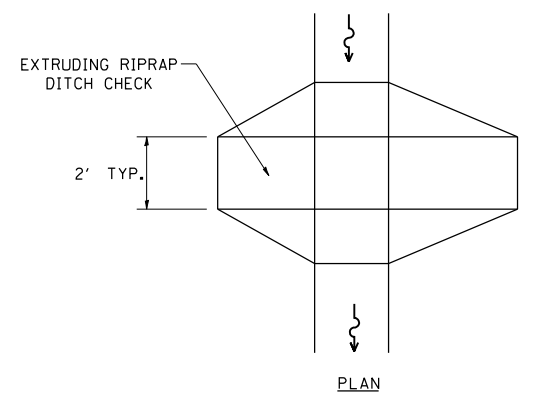

ELEVATION
OPTION 1
(EXTRUDING DITCH CHECK)
RECOMMENDED FOR AREAS
W/ RIPRAP DITCH LINING

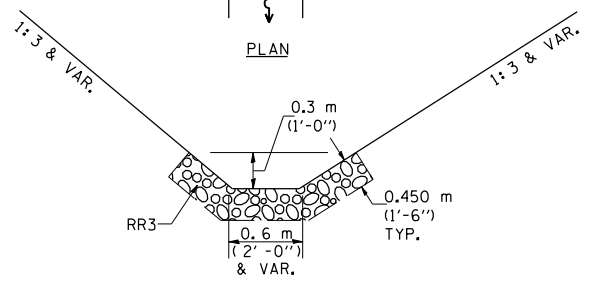
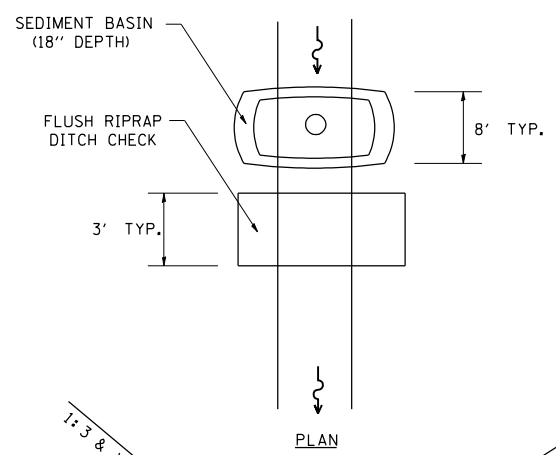

ELEVATION
OPTION 2
(FLUSH DITCH CHECK)
RECOMMENDED FOR AREAS
W/O RIPRAP DITCH LINING

STONE DUMPED RIPRAP DITCH CHECK
(TYPICAL & OPTIONS 1 & 2
AS DIRECTED BY THE ENGINEER)

NOTE 1: RIPRAP SHALL EXTEND FAR ENOUGH UP THE SLOPES TO ALLOW 0.3m (1') OVERTOPPING TO AVOID ERODING AROUND THE EDGES OF THE RIPRAP.

NOTE 2: ENDS SHALL BE TIED INTO SLOPES.

CONTRACTOR CERTIFICATION STATEMENT

This certification statement is part of the Storm Water Pollution Plan for the project described below in accordance with NPDES Permit No. ILR10 _____, issued by the Illinois Environmental Protection Agency on _____.

Route: FAP 304 Marked: IL-96
Section: 2(B-5,B-6) Project No.: _____
County: Pike County Contract No.: 72891

I certify under penalty of law that I understand the terms of the general National Discharge Elimination System (NPDES) permit that authorizes the storm water discharges associated with industrial activity from the construction site identified as part of this certification.

Signature _____ Date _____
Title _____
Name of Firm _____
Street Address _____
City, State, Zip _____
Phone Number _____

Note: The above boxed in area shall be filled out by the Contractor after the award of the contract to obtain the required NPDES Permit from IEPA. This is a requirement for this contract.

| REVISIONS | |
|-----------|------|
| NAME | DATE |
| | |
| | |
| | |
| | |
| | |
| | |
| | |
| | |
| | |
| | |

ILLINOIS DEPARTMENT OF TRANSPORTATION
STORM WATER POLLUTION PREVENTION PLAN
SHEET 3 OF 7
FAS ROUTE 304 (IL RTE 96)
SECTION 2(B-5,B-6)
PIKE COUNTY
SCALE: VERT.
HORIZ.
DATE