

S.B.L. RTE.	SECTION	COUNTY	TOTAL SHEETS	SHEET NO.
15B	(17C)B	WAYNE	17	15
STA. 1011+86.00		TO STA. 1011+98.00		
FED. ROAD DIST. NO. 7		ILLINOIS FED. AID PROJECT		

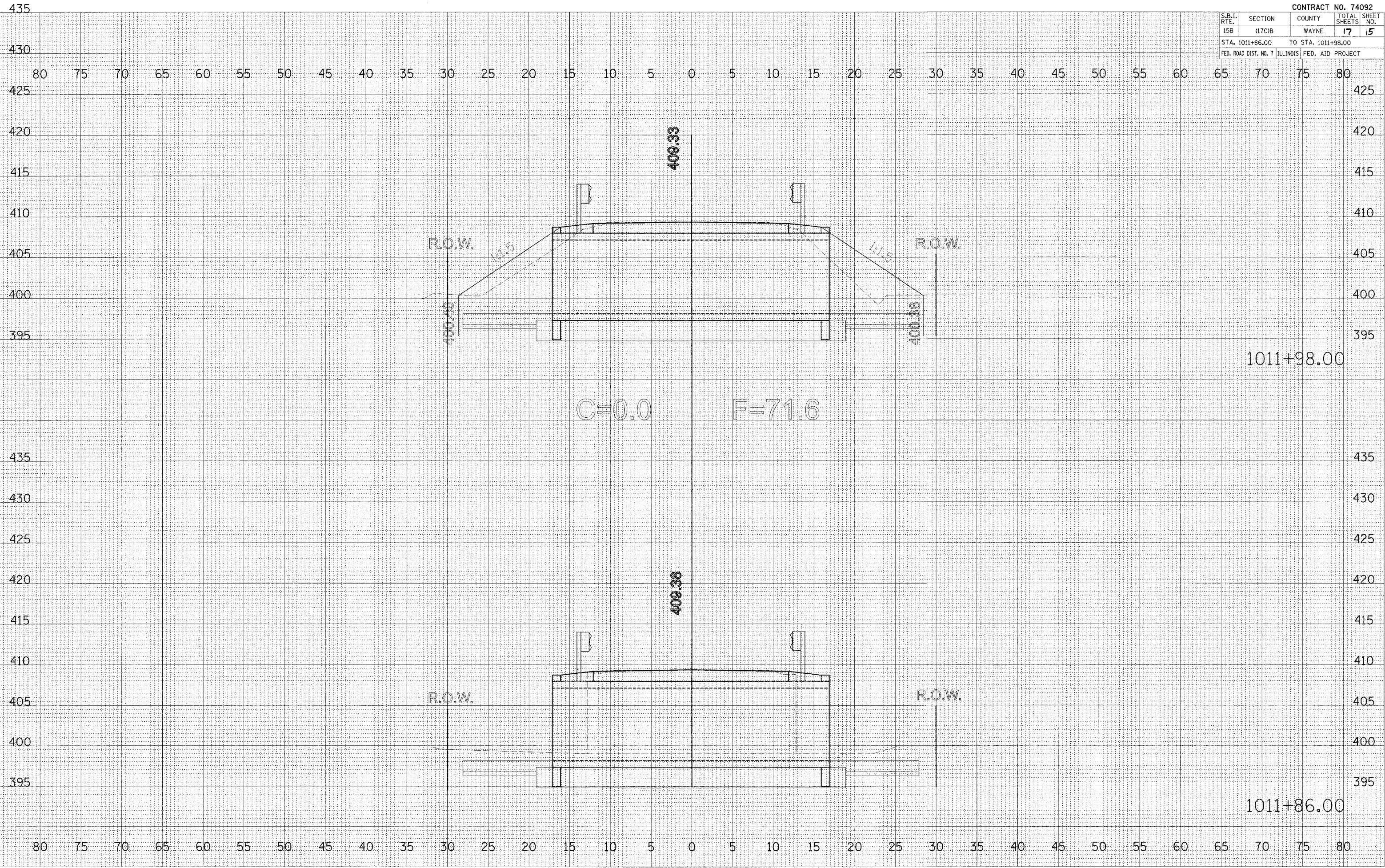

DATE: _____
 BY: _____
 SURVEYED: _____
 PLANNED: _____
 ORIGINAL SURVEY: _____
 TEMPLATE: _____
 AREAS CHECKED: _____
 NO.:

DATE: _____
 BY: _____
 SURVEYED: _____
 PLANNED: _____
 ORIGINAL SURVEY: _____
 TEMPLATE: _____
 AREAS CHECKED: _____
 NO.:

PLOT DATE = 9/24/2007
 FILE NAME = c:\projects\74092a\sheet_74092a550.dwg
 PLOT SCALE = 5/8" = 1' / IN.
 USER NAME = burmanbj