

**PROPOSED TYPICAL CROSS SECTION**  
19TH, 18TH, 15TH, & 11TH AVENUES

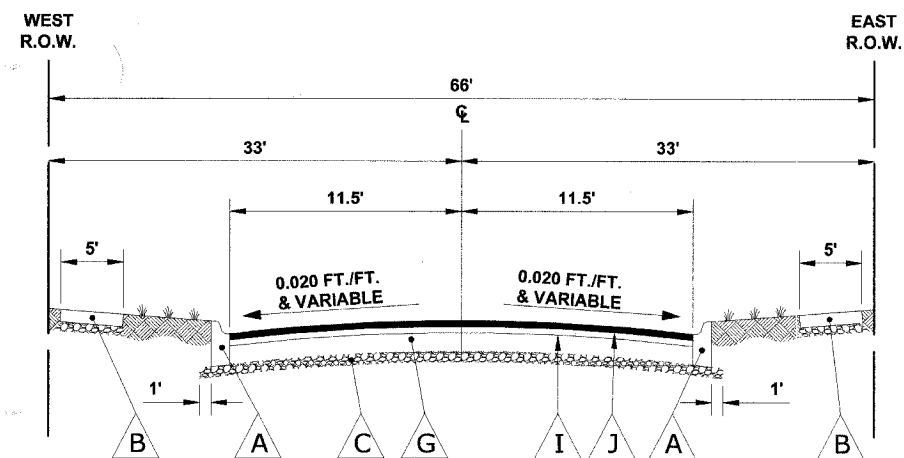

**PROPOSED TYPICAL CROSS SECTION**  
3RD AVENUE

**LEGEND OF SYMBOLS**

SYMBOL	DESCRIPTION
A	INTERMITTENT COMBINATION CONCRETE CURB & GUTTER, TYPE B-6.12 (MOD.)
B	INTERMITTENT PORTLAND CEMENT CONCRETE SIDEWALK, 5"
C	EXISTING SUB-BASE GRANULAR MATERIAL, 4"
D	EXISTING HOT-MIX ASPHALT SURFACE COURSE, 2"
E	EXISTING HOT-MIX ASPHALT BINDER COURSE, 2"
F	EXISTING CONCRETE BASE COURSE, 8"
G	EXISTING BRICK PAVER BASE COURSE
H	PROPOSED HOT-MIX ASPHALT SURFACE REMOVAL, 2-1/2"
I	PROPOSED POLYMERIZED LEVELING BINDER (MACHINE METHOD), IL-4.75, N50, MINIMUM 3/4"
J	PROPOSED HOT-MIX ASPHALT SURFACE COURSE, MIX C, N50, 1-3/4"

**HOT-MIX ASPHALT (HMA) MIXTURE REQUIREMENTS**

ITEM	A C TYPE	VOIDS
HMA SURFACE COURSE, MIX C, N50, IL-9.5 MM	PG 64-22	4% @ 50 GYR.
POLYMERIZED LEVELING BINDER (MACHINE METHOD), IL-4.75, N50	SBS/SBR PG 76-28/22	4% @ 50 GYR.

\* THE UNIT WEIGHT USED TO CALCULATE ALL HMA SURFACE COURSE IS 112 LBS/SQYD/IN AND THE UNIT WEIGHT USED TO CALCULATE POLYMERIZED LEVELING BINDER IS 105 LBS/SQYD/IN.

\* WHEN RAP EXCEEDS 20%, THE NEW ASPHALT BINDER IN THE MIX SHALL BE PG 58-22.

Drawing file: W:\Projects\56506359 - High Priority Comm\TSSCTS.dwg Apr 11, 2007 - 2:09pm