

F.A. SITE.	SECTION	COUNTY	TOTAL SHEETS	SHEET NO.
VAR. 2003-039 GRR	*	17	17	17
STA.	TO STA.			
FED. ROAD DIST. NO.	ILLINOIS	FED. AID PROJECT		

\* WILL, KENDAL, KANE, DU PAGE AND COOK  
**CONTRACT 62601**

NOTE:  
 FOR DETAILS OF RAIL ELEMENTS, RAIL SPLICING, NUT, BOLT AND SIDE VIEW OF RAIL, SEE STANDARD 630001

ALL WELDS SHALL BE GROUND SMOOTH

POSTS SHALL BE CUT AND WELDED TO THE BASE PLATE SO THAT THE POST WILL BE PLUMB WHEN ERECTED.

TWO PERCENT (2%) OF ALL ANCHOR BOLTS SHALL BE TEST LOADED IN PLACE, MINIMUM TEST LOAD=8 KIPS. IF ONE ANCHOR BOLT FAILS DURING THE TEST, TWO OTHER ANCHOR BOLTS SHALL BE TESTED. TESTING EQUIPMENT SHALL BE BOLT COMPANIES.

PROVIDE 1/8" AND 2/16" GALVANIZED SHIMS FOR 25% OF THE POSTS.

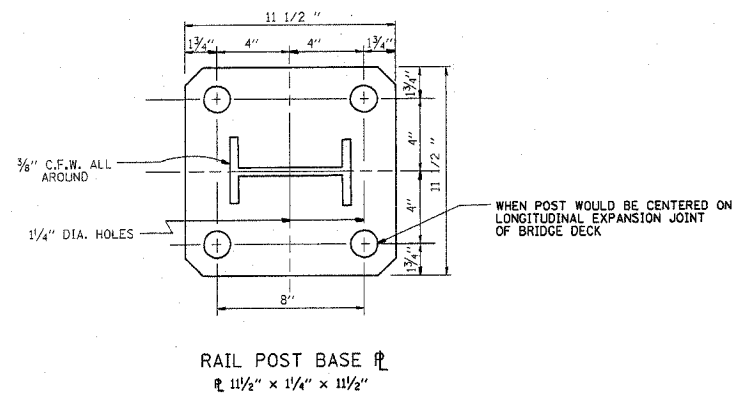

**NOTE:**  
 ALL WELDS SHALL BE GROUND SMOOTH. POSTS SHALL BE CUT AND WELDED TO THE TO THE BASE PLATE SO THAT THE POSTS WILL BE PLUMB WHEN ERECTED.

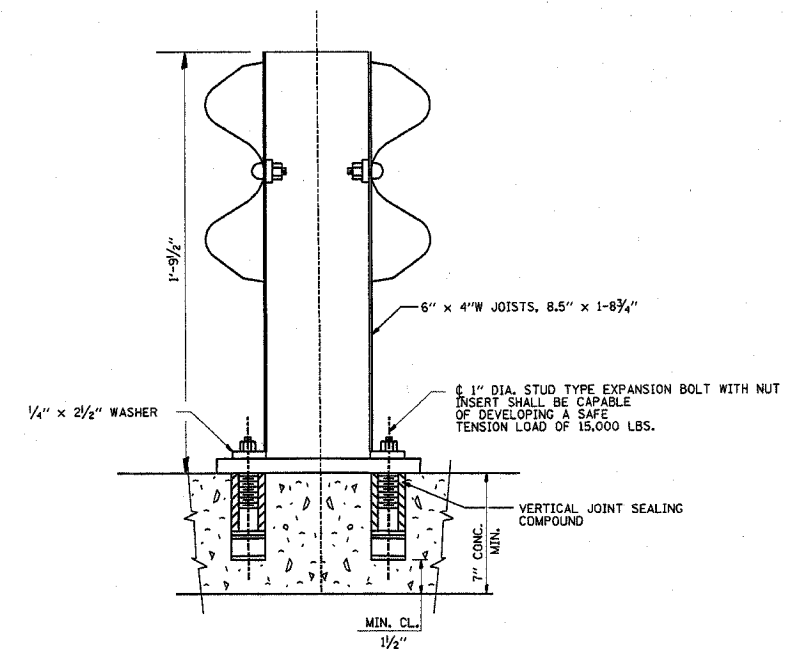

ILLINOIS DEPARTMENT OF TRANSPORTATION

**ANCHOR DETAIL FOR  
 STEEL PLATE BEAM GUARD RAIL  
 ON CONCRETE**

SCALE: NONE  
 DATE: 10-31-88

DRAWN BY R.F.L.  
 CHECKED BY

REVISIONS	
NAME	DATE
CREATED	10-31-88