

SECTION	COUNTY	TOTAL SHEETS	SHEET NO.
02-00090-00-BT	DUPAGE	117	36
STA. TO STA.			
IDOT PROJECT NO. M-8003(222)			
SALT CREEK GREENWAY TRAIL			
CONTRACT NO. 83713			

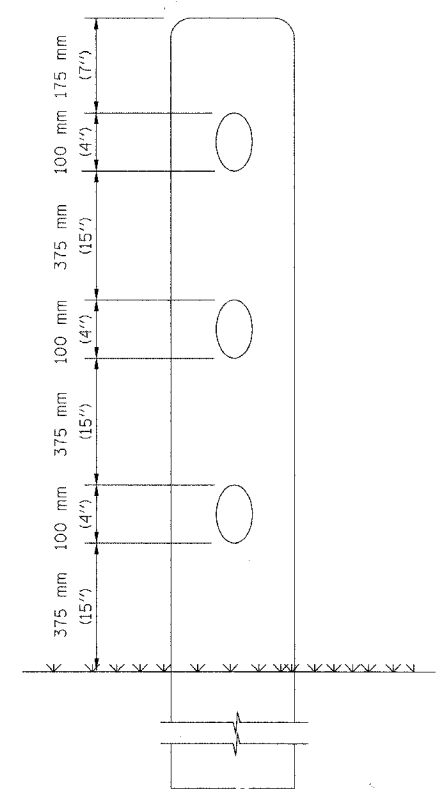

**SIDE VIEW**

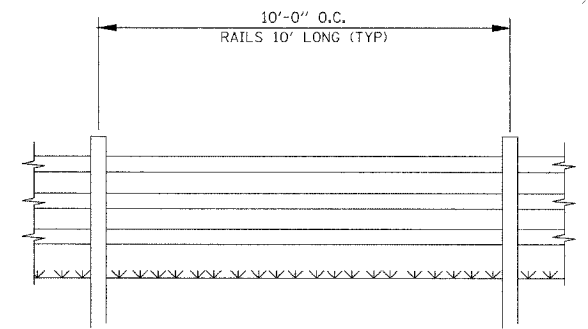

**FRONT VIEW**

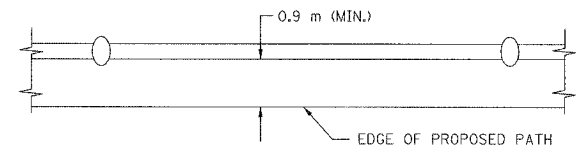

**TOP VIEW**

NOTE: ALL RAILS SHALL BE SPIKED TO POST W/GALVANIZED GUTTER SPIKES.

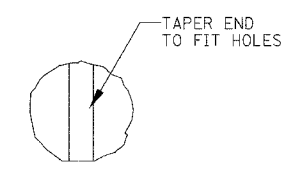

**RAIL END (TYP.)**

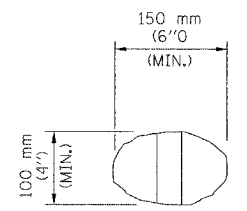

**LINE POST-TOP (TYP.)**

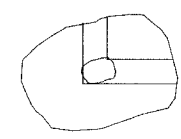

**CORNER POST-TOP (TYP.)**

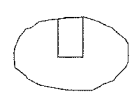

**END POST TOP (TYP.)**

**RUSTIC RAIL FENCE DETAIL**

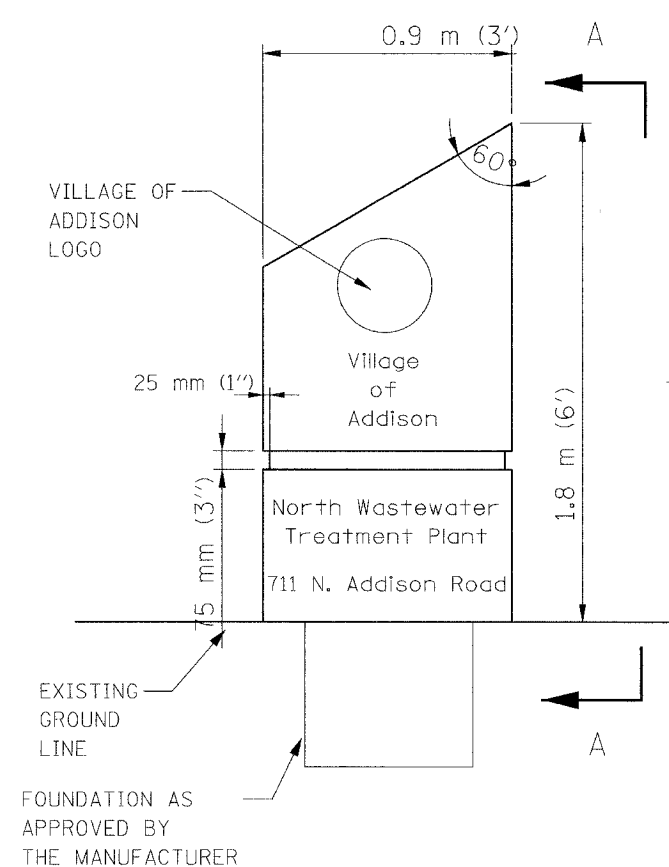

**ENTRANCE MONUMENT DETAIL**

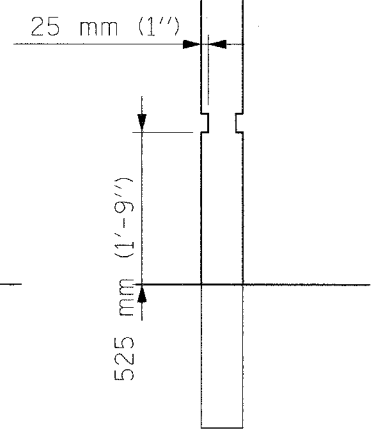

**SECTION A-A**

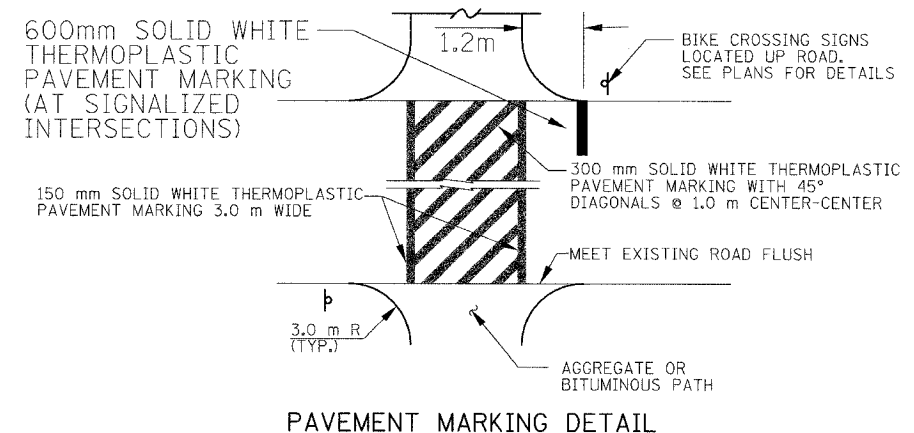

**PAVEMENT MARKING DETAIL**

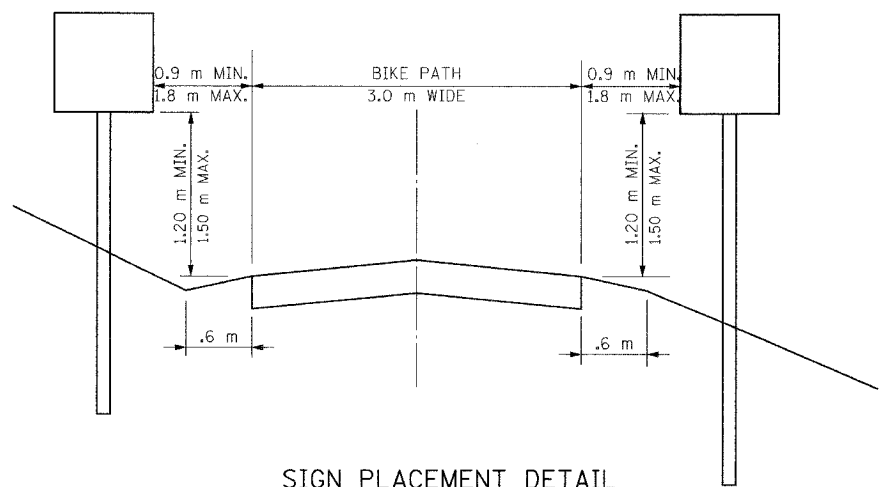

**SIGN PLACEMENT DETAIL**

REVISIONS		
NO.	NAME	DATE

**URS** 1701 GOLF ROAD, SUITE 1000 TEL (847) 228-0707  
 ROLLING MEADOWS, IL 60008 FAX (847) 228-1115

VILLAGE OF ADDISON  
**SALT CREEK GREENWAY TRAIL**  
**MISCELLANEOUS DETAILS**

DATE: 10/22/04 DRAWN BY: MIA&VP  
 DESIGNED BY: MIA CHECKED BY: DDL