

ROUTE NO.	SECTION	COUNTY	TOTAL SHEETS	SHEET NO.
C.H. 5	04-00163-00-BR	STEPHENSON	29	13
		ILLINOIS		

Sheet 8 of 20 CONTRACT NO. 85391

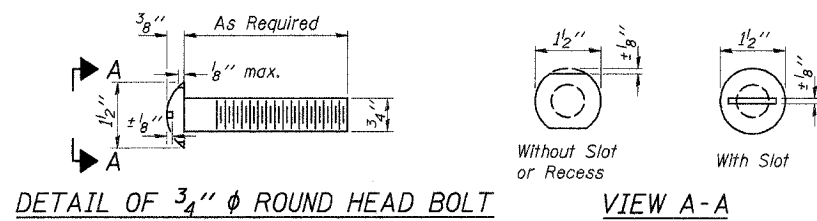

DETAIL OF 3/4" ϕ ROUND HEAD BOLT

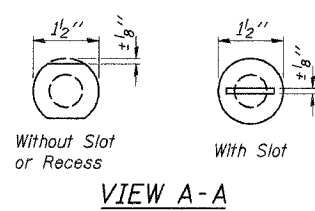

VIEW A-A

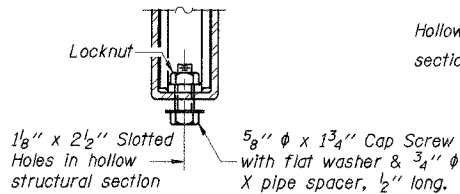

RAIL SPLICE CONNECTION AT EXPANSION JT.

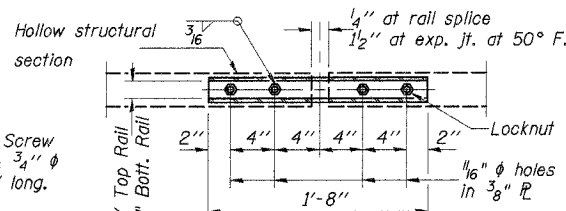

PLAN-BOTT. SPLICE R TYPICAL

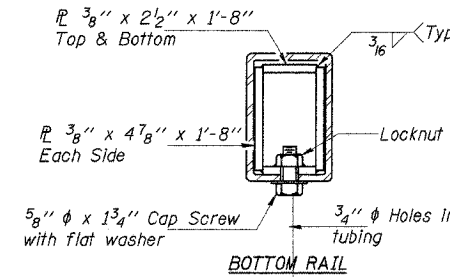

SECTIONS AT RAIL SPLICE

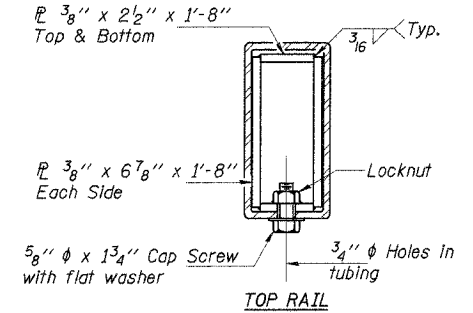

NOTES

Hollow structural sections shall conform to the requirements of ASTM designation A 500 Grade B Structural Steel Tubing and shall meet the longitudinal CVN requirements of 15 ft-lbs at 0° F.

All other steel shapes and plates shall conform to the requirements of AASHTO M 270 Grade 36 except posts and angles shall conform to AASHTO M 270, Grade 50.

Bolts, cap screws, and nuts shall conform to the requirements of ASTM designation A 307 except for high strength bolts, nuts and washers noted which shall conform to AASHTO M 164.

All bolts, nuts, cap screws, washers and lock washers shall be galvanized according to AASHTO M 232.

All posts, railing, rail splices, anchor devices and angles shall be galvanized after shop fabrication according to AASHTO M 111 and ASTM A 385. Galvanized rail shall not be painted.

Railing shall be according to Section 509 of the Standard Specifications, except as noted, and will be paid for at the contract unit price per foot for Steel Bridge Rail, Type SM.

All field drilled holes shall be coated with an approved zinc rich paint before erection.

For multi-span bridges, sufficient 1/4" x 6" x 1'-2" galvanized steel shims shall be provided to align rail between adjacent spans. Cost included with Steel Bridge Rail, Type SM.

The 1/2" x 7" x 6" plates that come in contact with concrete shall receive two coats of asphalt paint conforming to Section 1060.07 Type II or place 1/2" fabric bearing pads between the plates and concrete.

The 3/4" ϕ high strength bolts used to connect the 6 x 4 x 3/4 angles to the post shall be tightened according to Article 505.04(f)(2) of the Standard Specifications. The 1" ϕ high strength bolts connecting the angles to the concrete shall be tightened to a snug fit and given an additional 1/2 turn. The 5/8" ϕ cap screws in bottom of posts shall be tightened to a snug fit only.

Note: See Sheet 2 of 20 for Post Spacing

BILL OF MATERIAL

Item	Unit	Quantity
Steel Bridge Rail, Type SM	Foot	314

STEEL BRIDGE RAIL, TYPE SM

SECTION 04-00163-00-BR
F.A.S. ROUTE 60 - C.H. 5
STEPHENSON COUNTY
STATION 255+30

4440 ASH GROVE
SPRINGFIELD, IL 62711
(217) 793-8600
oasinc@insightbb.com

OZYURT AND STONE, INC.
CONSULTING ENGINEERS

JOB NO.: 0527
FILE: 0527RAIL.DGN
DATE: 03/07/06

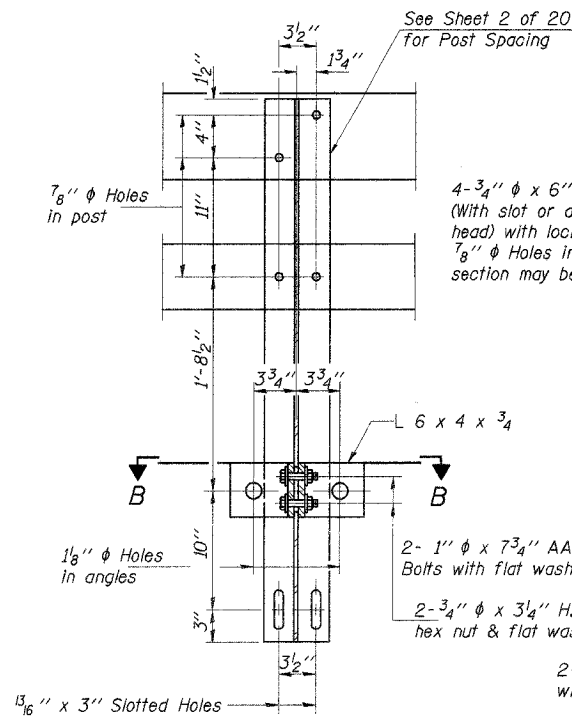

SECTION A-A

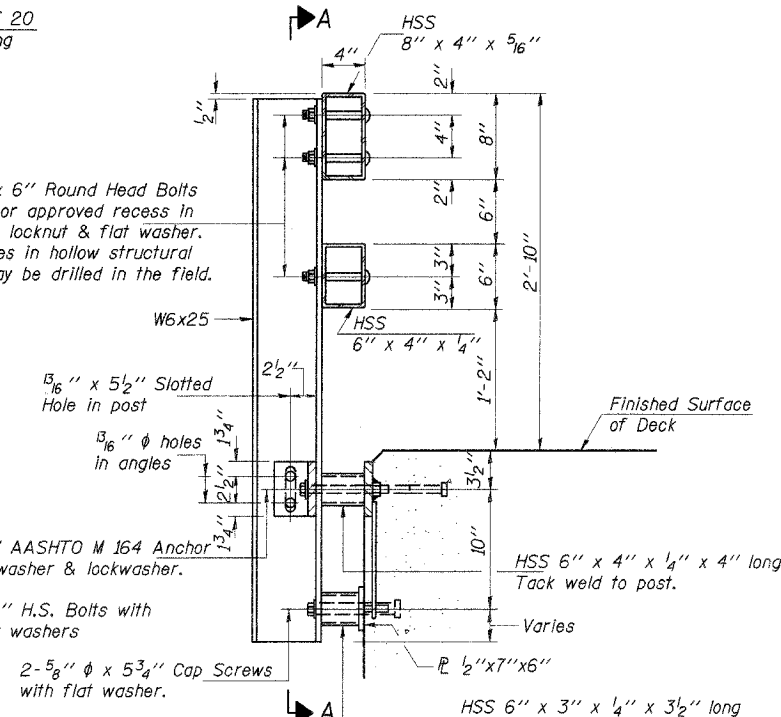

SECTION AT RAIL POST

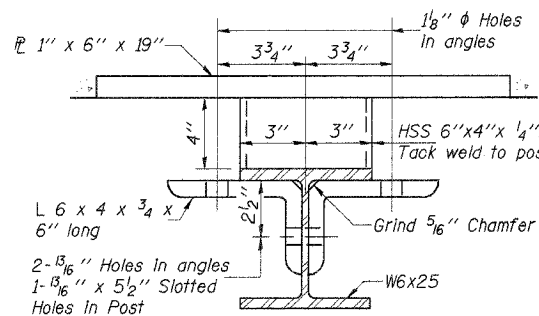

SECTION B-B

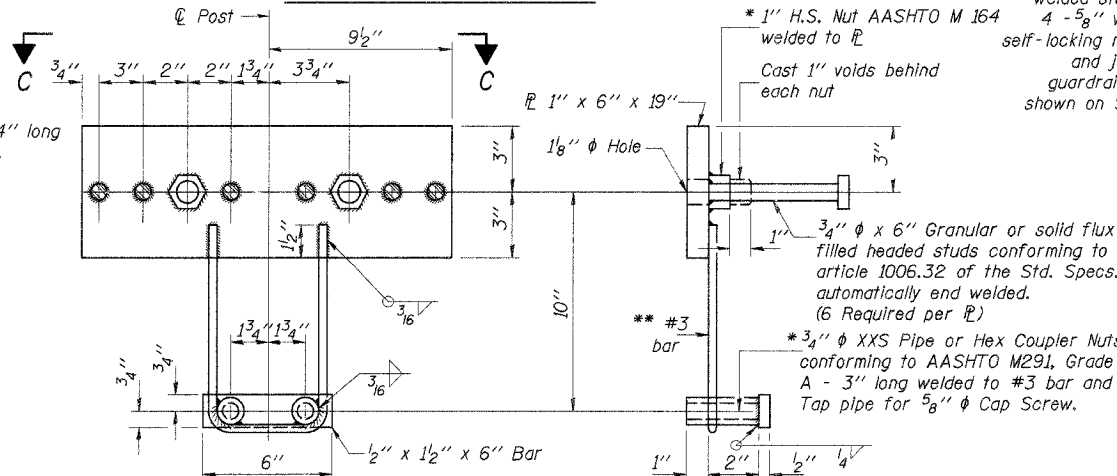

ANCHOR DEVICE

* Threaded areas shall be plugged or blocked off during casting of beam. Galvanized after fabrication.

** Whenever the lower insert assemblies interfere with strand locations, the #3 bars shall be cut and adjusted in order to allow raising or lowering of the lower inserts. Maximum adjustment not to exceed 1/2".

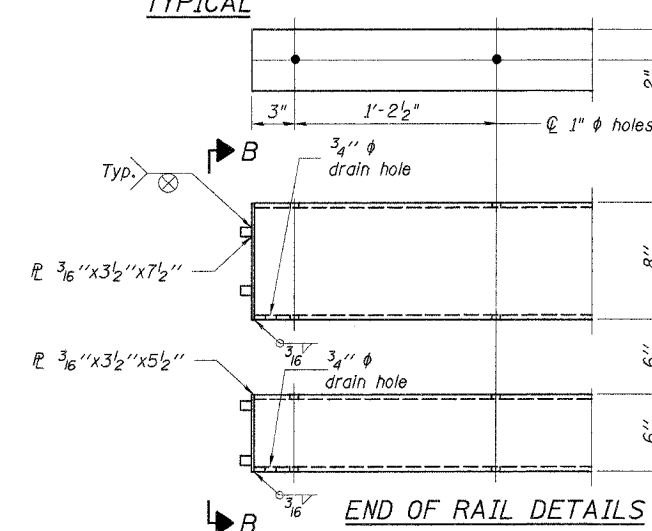

END OF RAIL DETAILS

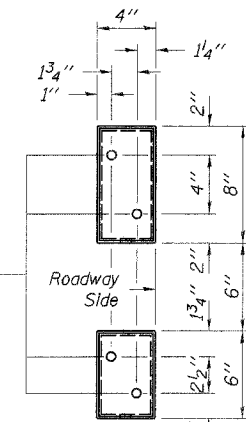

VIEW B-B

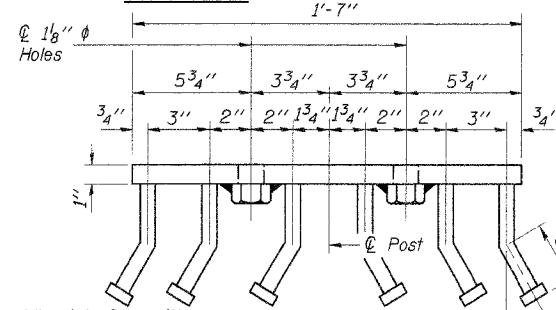

VIEW C-C

DESIGNED	A.R.K.
CHECKED	S.F.M. & F.J.S.
DRAWN	S.A.P.
CHECKED	A.R.K. & F.J.S.

9-01-03 (6'-3" Maximum Post Spacing)