

ROUTE NO.	SECTION	COUNTY	TOTAL SHEETS	SHEET NO.
T.R. 167	06-01102-01-BR	PIATT	15	5
ROAD DIST.	ILLINOIS		BEMENT	

CONTRACT NO. 91364

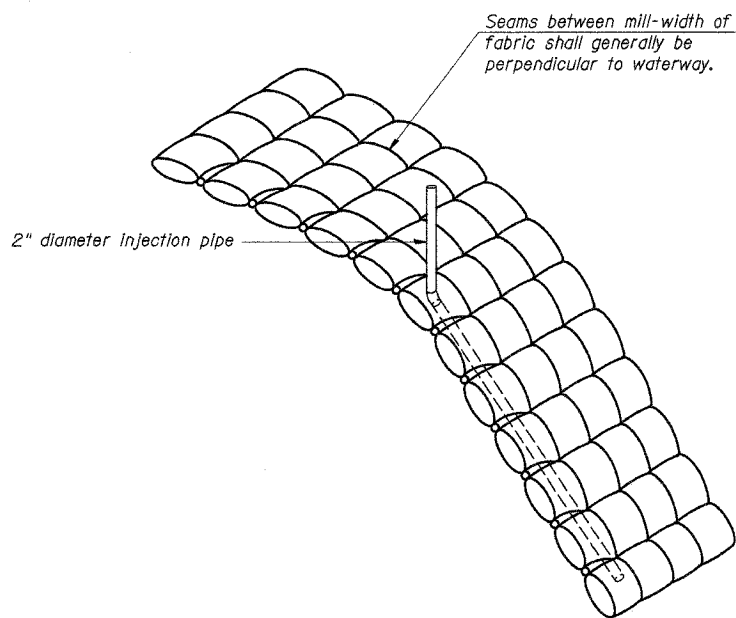

**INSTALLATION DETAIL**

Locate mortar stops to accommodate mortar quantities to be injected.

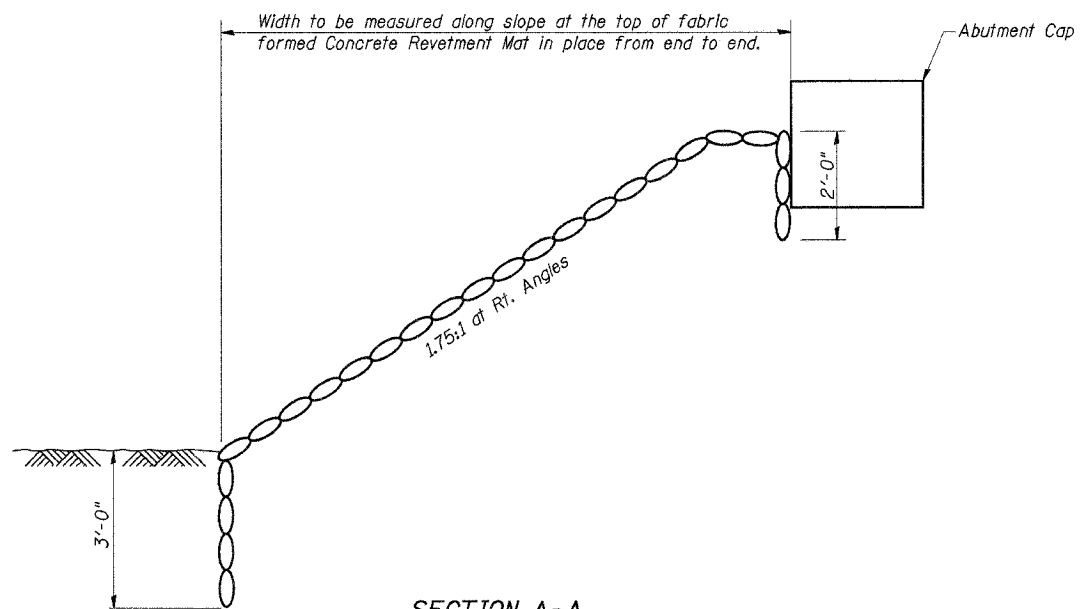

**SECTION A-A**

**TYPICAL FABRIC FORMED CONCRETE REVETMENT MAT LINE**

See Sheet 4 for Location

**GENERAL NOTES**

In placing insert points through fabric use extreme care to avoid breaking drop stitches.

Injection points shall be no more than 30 feet apart on the horizontal.

Cut off walls shall be installed at the upstream and downstream ends of the mat.

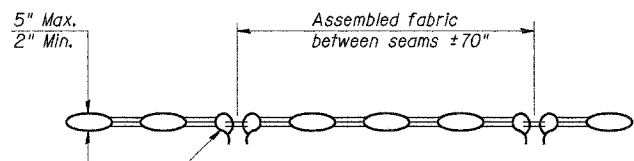

Locate field sewn joint midway between mortar stops. Lay seams down for best appearance.

**TYPICAL SECTION THRU FILTER POINT MAT**

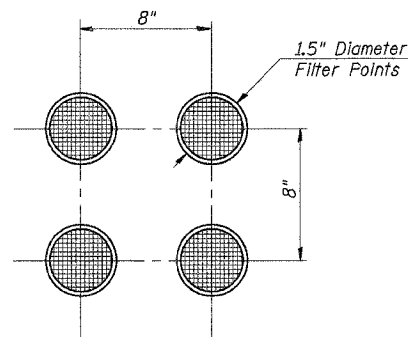

**LAYOUT OF FILTER POINTS**

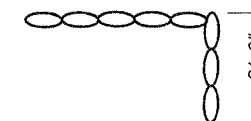

**SECTION B-B**

See Sheet 4

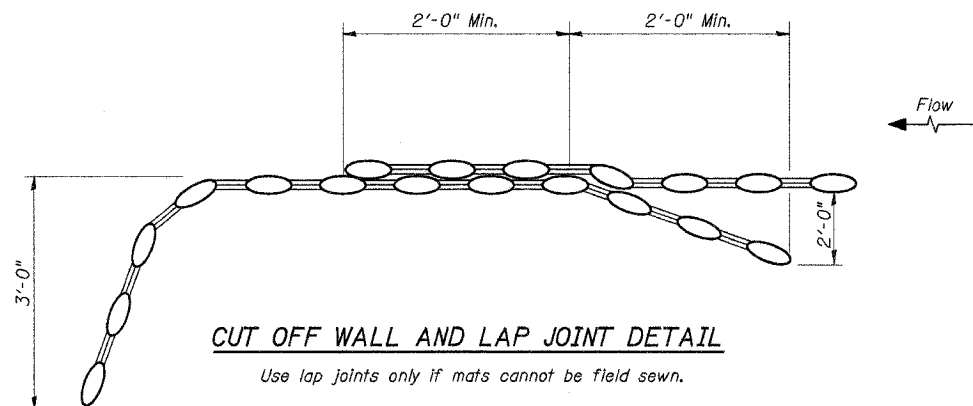

**CUT OFF WALL AND LAP JOINT DETAIL**

Use lap joints only if mats cannot be field sewn.

**BILL OF MATERIAL**

Item	Unit	Quantity
Fabric Formed Concrete Revetment Mat	Sq. Yd.	173

DESIGNED	F.J.S.
CHECKED	S.F.M.
DRAWN	S.A.P.
CHECKED	S.F.M.

**CONCRETE REVETMENT MAT DETAILS**

SECTION 06-01102-01-BR  
BEMENT ROAD DISTRICT  
PIATT COUNTY  
STATION 5+06.55

4440 ASH GROVE  
SPRINGFIELD, IL 62711  
(217) 789-8600  
oasinc@insightbb.com

**Fehr-Graham & Associates, LLC**  
ENGINEERING AND SCIENCE CONSULTANTS  
PEELPOLE, IL. ROCKFORD, IL. ROCKFORD, IL. ROCKFORD, IL. SPRINGFIELD, IL.

JOB NO.: 0602  
FILE: 0602REVMAT.DGN  
DATE: 05/26/06