

F.A.I. RTE.	SECTION	COUNTY	TOTAL SHEETS	SHEET NO.
57	44-1L, 44-3L	JOHNSON	15	1

*FAI 57 & FAI 24
**(44-1)L, (44-3)L

STATE OF ILLINOIS
DEPARTMENT OF TRANSPORTATION
DIVISION OF HIGHWAYS

**PROPOSED
HIGHWAY PLANS**

FAI 57 & FAI 24 (I-57 & I-24)
SECTION (44-1)L, (44-3)L
PROJECT: IM-000S(520)

JOHNSON COUNTY
C-99-048-06

D-99-040-06

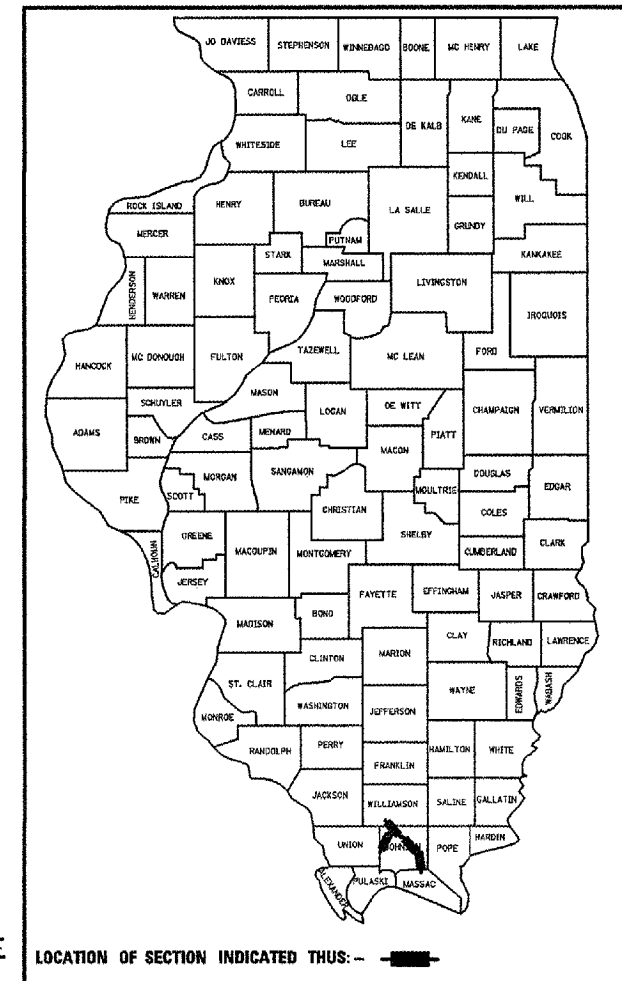

FOR INDEX OF SHEETS, SEE SHEET NO. 2

ADT (2005) I-57 AND GOREVILLE- ADT = 12,400 ON RAMPS - 40 ON FAS 1931 = 1150 TRUCK = 5650 (45.5%)	ADT (2005) I-24 (PULLEY'S MILL) ADT = 15,900 TRUCK = 35%
I-24 AND TUNNEL HILL- ADT = 15,900 ON RAMPS = 7 ON FAS 927 = 1250 TRUCK = 5700 (35.8%)	I-24 AND US 45 NORTH OF VIENNA (2005)- ADT = 15,500 TRUCK = 35%

LOCATION 4: FAI 24 - PROP. PAVEMENT SENSOR
REPAIR NEAR PULLEY'S MILL INTERCHANGE
IN JOHNSON CO.

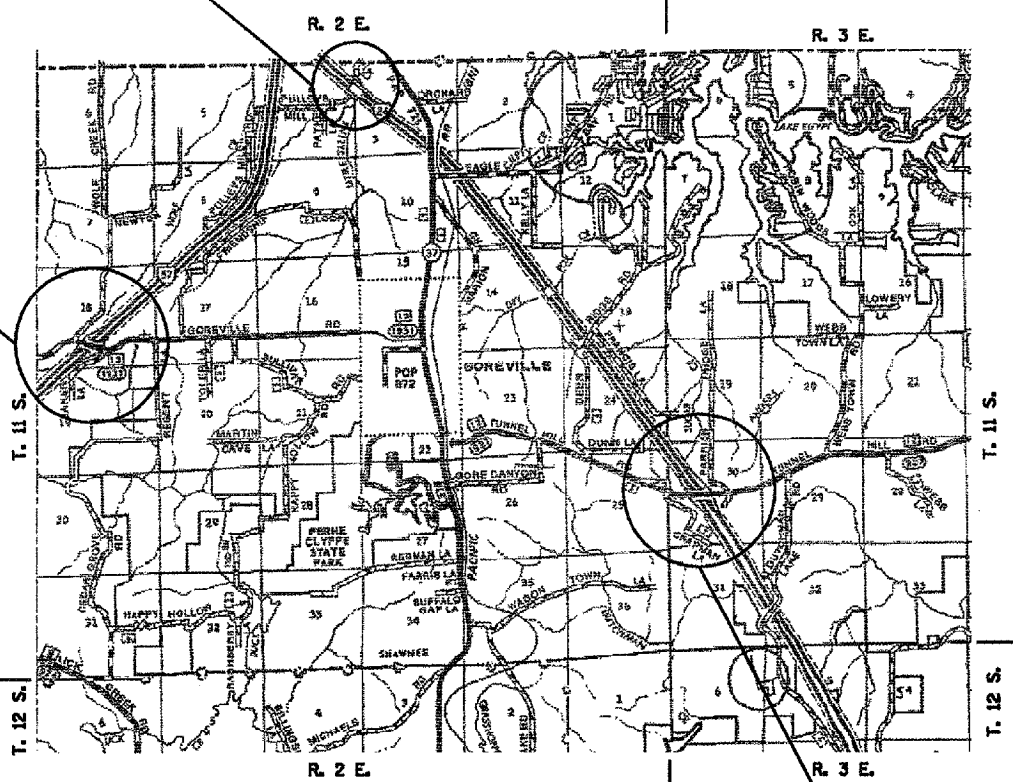

LOCATION 1: FAI 57 - PROP.
LIGHTING IMPROVEMENT
GOREVILLE INTERCHANGE IN
JOHNSON CO.

TOWNSHIPS: GOREVILLE, TUNNEL HILL
AND BLOOMFIELD

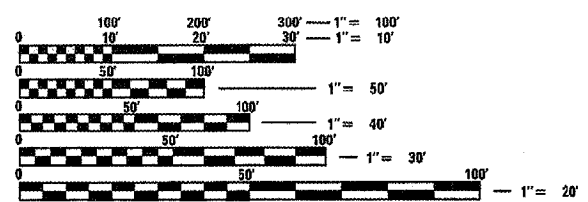

FULL SIZE PLANS HAVE BEEN PREPARED USING STANDARD
ENGINEERING SCALES. REDUCED SIZED PLANS WILL NOT
CONFORM TO STANDARD SCALES. IN MAKING MEASUREMENTS
ON REDUCED PLANS, THE ABOVE SCALES MAY BE USED.

J.U.I.E.
JOINT UTILITY LOCATION INFORMATION FOR EXCAVATION
1-800-892-0123

LOCATION 2: FAI 24 - PROP. LIGHTING IMPROVEMENT
TUNNEL HILL INTERCHANGE IN JOHNSON CO.

LOCATION 3: FAI 24 - PROP. LIGHTING
UNIT DUCT REPAIR AT US 45 INTERCHANGE

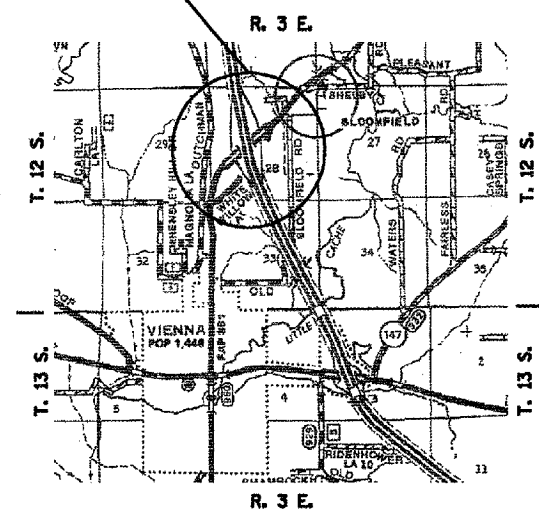

STATE OF ILLINOIS
DEPARTMENT OF TRANSPORTATION
DIVISION OF HIGHWAYS

SUBMITTED August 23, 2006
Mary C. Linnell
DEPUTY DIRECTOR OF HIGHWAYS, REGION ENGINEER

October 13, 2006
Mike Hene
ENGINEER OF DESIGN AND ENVIRONMENT

October 13, 2006
Milton R. Sees, P.E.
DIRECTOR OF HIGHWAYS, CHIEF ENGINEER

**PRINTED BY THE AUTHORITY
OF THE STATE OF ILLINOIS**

PROJECT ENGINEER: CHARLES STEIN - (618)351-5210
DESIGN TECHNICIAN: KATHI MCCORD - (618)351-5216

CONTRACT NO. 98981

F.A.I. RTE.	SECTION	COUNTY	TOTAL SHEETS	SHEET NO.
		JOHNSON	15	2
STA.		TO STA.		
FED. ROAD DIST. NO.		ILLINOIS FED. AID PROJECT		
*FAI 57 & FAI 24				
**44-1L, 144-3L				

INDEX OF SHEETS

SHEET NO.	DESCRIPTION
1	COVER SHEET
2	SIGNATURE BLOCK, INDEX OF SHEETS, GENERAL NOTES, HIGHWAY STANDARDS
3	SUMMARY OF QUANTITIES
4	SCHEDULES: POLE LOCATIONS, SOIL BORINGS
5 - 6	LOCATION 1 - I-57 AT GOREVILLE INTERCHANGE LIGHTING LOCATION
7 - 9	LOCATION 2 - I-24 AT TUNNEL HILL INTERCHANGE LIGHTING LOCATION
10	LOCATION 3 - I-24 AND US 45 INTERCHANGE ELECTRIC WIRE REPLACEMENT
11	LOCATION 4 - I-57 AND I-24 AT PULLEY'S MILL INTERCHANGE - STA. 150+50 EAST OF INTERCHANGE ON I-24 PAVEMENT SENSOR REPLACEMENT
12	WIRING DIAGRAMS
13	LIGHTING POLE STANDARD
14	LIGHT POLE FOUNDATION STANDARD
15	CONTROL INSTALLATION TYP CB-RCS-60

HIGHWAY STANDARDS

000001-04	701301-02
701001-01	701400-02
701006-02	701406-04
701011-01	702001-06
701101-01	805001
701106-01	

GENERAL NOTES

1. THE LIGHT POLES SHALL BE SIGNED WITH THE POLE NUMBER AS SHOWN ON THE WIRING DIAGRAM.
2. ROCK EXCAVATION QUANTITIES ARE ESTIMATES. SEE PLAN SHEETS AND SOIL BORING LOGS FOR LOCATION OF ROCK EXCAVATION.
3. CABLE QUANTITIES ARE MEASURED IN PLAN VIEW.
4. IN AREAS WHERE MULTIPLE RUNS OF PARALLEL CONDUIT ARE IN THE SAME LOCATION, TRENCH AND BACKFILL WILL ONLY BE PAID FOR ONCE.
5. PROPOSED LIGHT POLE FOUNDATION SHALL BE FLUSH WITH EXISTING SURFACE.
6. EXISTING SURFACE DISTURBED DURING EXCAVATION FOR FOUNDATIONS AND PUSH PITS SHALL BE RESTORED TO THE LIMITS AND CONDITION SPECIFIED BY THE ENGINEER OR AS SHOWN ON THE PLANS. THIS INCLUDES ANY SEEDING OR MULCHING NEEDED. UNLESS NOTED OTHERWISE ON THE PLANS THE REMOVAL AND RESTORATION SHALL BE INCLUDED IN THE CONTRACT.
7. ALL ELECTRIC CABLE AND CONDUIT QUANTITIES ARE ROUNDED UP TO THE NEAREST 1.52 m (5 FT).
8. CONCRETE IN-GROUND FOUNDATIONS FOR LIGHT POLES MAY BE USED INSTEAD OF LIGHT POLE FOUNDATIONS, METAL. THE COST OF THE FOUNDATION SHALL BE THE CONTRACT UNIT PRICE FOR LIGHT POLE FOUNDATION, METAL, 15" BOLT CIRCLE, 8" X 6".
9. COMMITMENTS: NONE

Prepared By:	<i>Joe Zdaniewicz</i> DISTRICT STUDIES & PLANS ENGINEER
Examined By:	<i>James Travis Emery</i> DISTRICT LAND ACQUISITION ENGINEER
Examined By:	<i>Carrie Nulser</i> DISTRICT PROGRAM DEVELOPMENT ENGINEER
Examined By:	<i>Kevin Hammer</i> DISTRICT OPERATIONS ENGINEER
Examined By:	<i>Joseph Lynn</i> DISTRICT CONSTRUCTION ENGINEER
Examined By:	<i>Bruce P. P. P.</i> DISTRICT MATERIALS ENGINEER
Examined By:	<i>Jim Smith</i> DISTRICT PROJECT IMPLEMENTATION ENGINEER
Examined By:	<i>Samuel Clayton</i> ASSISTANT REGIONAL ENGINEER
Approved By:	<i>Wally Kamin</i> DEPUTY DIRECTOR OF HIGHWAYS, REGION ENGINEER
DATE	Aug 21 2006

Rev.

PLOT DATE : 8/16/2006
 FILE NAME : c:\projects\98981\98981-157-124119.mxd
 USER : jbruce
 USER NAME : jbruce

F.A.I. RTE.	SECTION	COUNTY	TOTAL SHEETS	SHEET NO.
..5JOHNSON..	..15..	..3
STA.	TO STA.			
FED. ROAD DIST. NO. ILLINOIS FED. AID PROJECT				

*FAI 57 & FAI 24
 **44-1L, 44-3L

SUMMARY OF QUANTITIES

CODE NO.	ITEM DESCRIPTION	UNIT	TOTAL QUANTITY	LOCATION 1	LOCATION 2	LOCATION 3	LOCATION 4
				FAI 57 & FAS 1931 GOREVILLE INTERCHANGE	FAI 24 & FAS 927 TUNNEL HILL INTERCHANGE	FAI 24 & US 45 INTERCHANGE AT VIENNA	FAI 24 EAST OF PULLEY'S MILL INTERCHANGE
				RURAL	RURAL	RURAL	RURAL
				90% FED., 10% STATE	90% FED., 10% STATE	90% FED., 10% STATE	90% FED., 10% STATE
				LIGHTING JOHNSON Y030-1E QUANTITY	LIGHTING JOHNSON Y030-1E QUANTITY	LIGHTING JOHNSON Y030-1E QUANTITY	PAVEMENT SENSORS JOHNSON Y030-1E QUANTITY
X0322763	FURNISH AND INSTALL PAVEMENT SENSORS	EACH	2				2.0
*50200400	ROCK EXCAVATION FOR STRUCTURES	CU YD	31.0	1.0	19.0	11.0	
67100100	MOBILIZATION	L SUM	1.0	0.5	0.5		
67000400	ENGINEER FIELD OFFICE, TYPE A	CAL MO	3.0	1.5	1.5		
70100700	TRAFFIC CONTROL AND PROTECTION, STANDARD 701406	L SUM	1.0				1.0
80300100	LOCATING UNDERGROUND CABLE	FOOT	20.0			20.0	
80400100	ELECTRIC SERVICE INSTALLATION	EACH	2.0	1.0	1.0		
81021550	CONDUIT, AUGURED 2" DIA., PVC	FOOT	940.0	300.0	480.0	160.0	
81021590	CONDUIT, AUGURED 4" DIA., PVC	FOOT	45	45			
81500200	TRENCH AND BACKFILL FOR ELECTRICAL WORK	FOOT	10165.0	4,665.0	4,875.0	625.0	
81600415	UNIT DUCT 2" 4 XLP GROUND 1" POLYETHYLENE	FOOT	4365	4365			
81600315	UNIT DUCT, 2" 6XLP, 1" 6 XLP GROUND 1" POLYETHYLENE	FOOT	6140		5,355.0	785.0	
82103900	LUMINAIRE, SODIUM VAPOR, MULTI-MOUNT, 250 WATT	EACH	28.0	14.0	14.0		
83034400	LIGHT POLE, STEEL, 45 FT. M. H., TENON MOUNT	EACH	20.0	10.0	10.0		
83035400	LIGHT POLE, STEEL, 45 FT. M. H., TENON MOUNT - TWIN	EACH	4.0	2.0	2.0		
83600355	LIGHT POLE FOUNDATION METAL, 15" BOLT CIRCLE, 8" X 6"	EACH	20.0	10.0	10.0		
83600357	LIGHT POLE FOUNDATION METAL, 15" BOLT CIRCLE, 8" X 8"	EACH	4.0	2.0	2.0		
83800650	BREAKAWAY DEVICE, COUPLING, WITH STAINLESS STEEL SCREEN	EACH	96.0	48.0	48.0		
82500510	LIGHTING CONTROLLER CB-RCS 60 AMP - 240 VOLT	EACH	2.0	1.0	1.0		
87900100	DRILL EXISTING FOUNDATION	EACH	2.0			2.0	

PLOT DATE = 8/22/2005
 FILE NAME = C:\Users\mcc\Documents\98981\98981.dwg
 PLOT SCALE = 1/8" = 1'-0"
 USER NAME = mccorker

Rev. *SPECIALTY ITEMS

F.A.I. RTE.	SECTION	COUNTY	TOTAL SHEETS	SHEET NO.
		JOHNSON	15	4
STA.		TO STA.		
FED. ROAD DIST. NO.		ILLINOIS	FED. AID PROJECT	

*FAI 57 & FAI 24
**44-1L, 44-31L

GOREVILLE INTERCHANGE
LIGHT POLE SCHEDULE

STATION LT. or RT.	LIGHT POLE NO.	LIGHT POLE M. H.	SETBACK FROM E. P.
Goreville Interchange			
Ramp A		FEET	FEET
Rt. 2+55	1	45	30
Rt. 5+05	2	45	25
Rt. 7+55	3	45	20
FAS 1931			
Rt. 17+13	4A	45	30
Rt. 17+13	4B	45	30
Rt. 15+73	5	45	25
Rt. 14+30	6	45	20
Lt. 11+58	7	45	20
Lt. 9+76	8	45	25
Lt. 7+88	9A	45	30
Lt. 7+88	9B	45	30
Ramp C			
7+87	10	45	30
5+37	11	45	30
2+87	12	45	30

TUNNEL HILL INTERCHANGE
LIGHT POLE SCHEDULE

STATION LT. OR RT.	LIGHT POLE NO.	LIGHT POLE M. H.	SETBACK FROM E. P.
Tunnel Hill Interchange			
I-57		FEET	FEET
Lt. 448+16	1	45	30
Lt. 445+72	2	45	30
Ramp B			
Rt. 2+39	3	45	30
RAMP A			
RT. 10+00 TO RT. 16+00			
FAS 927			
Rt. 59+39	4A	45	30
Rt. 59+39	4B	45	30
Rt. 57+34	5	45	30
Rt. 55+45	6	45	20
Lt. 51+26	7	45	20
Lt. 49+32	8	45	30
Lt. 48+40	9A	45	30
Lt. 48+40	9B	45	30
Ramp D			
Rt. 2+47	10	45	30
I-57			
Rt. 418+19	11	45	30
Rt. 415+70	12	45	30

SOIL BORING SCHEDULE

LOCATION	STATION	LT. OF CENTERLINE	RT. OF CENTERLINE	DEPTH OF ROCK	ROCK EXCAVATION FOR STRUCTURES
Goreville Interchange on I-57					
RAMP A		FEET	FEET	FEET	CU YD
LIGHT POLE 1	2+55		31	8.0	
LIGHT POLE 2	5+05		25	2.0	1.0
LIGHT POLE 3	7+55		18	8.0	
Tunnel Hill Interchange on I-24					
RAMP B					
LIGHT POLE 3	2+39		21	21.5	
I-24 (ALONG RAMP B)					
LIGHT POLE 2	445+72	21		13.0	
LIGHT POLE 1	448+14	17		11.0	
RAMP A					
EDGE OF PAVEMENT	11+00		10	.5 TO 1	19*
I-24 MEDIAN	418+65			2.0	
I-24 MEDIAN	431+92			2.0	
Vienna Interchange at I-24 and US 45					
I-24 MEDIAN	360+00			0.5	11*
TOTAL					31.0

* QUANTITY REFLECTS ROCK EXCAVATION FOR UNIT DUCT BEING TRENCHED THROUGH AREA WHERE ROCK EXISTS.







PLOT DATE = 8/22/2005
FILE NAME = c:\projects\98991\17-241\sp032
PLOT SCALE = 1/8"=1'-0"
USER NAME = mcarroll

F.A.I. RTE.	SECTION	COUNTY	TOTAL SHEETS	SHEET NO.
		JOHNSON	15	5
STA.	TO STA.			
FED. ROAD DIST. NO.	ILLINOIS FED. AID PROJECT			
	*FAI 57 & FAI 24			
	**44-11L, 44-31L			

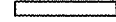
NOTE:
 STA. 173+19.49 (I57)=
 STA. 0+00 @ RAMP "C"

PLAN LAYOUT FOR I-57 & GOREVILLE INTERCHANGE LIGHTING

LEGEND

-  PROPOSED CONDUIT, AUGURED 2" DIA., PVC (4" WHERE NOTED)
-  PROP. UNIT DUCT, 2*4 XLP, 1*4 XLP GROUND 1" POLYETHYLENE
-  PROP. LIGHT POLE, STEEL, 45' M.H., TENON MOUNT WITH 250 WATT SODIUM VAPOR LUMINAIRE, MULTI-MOUNT. NUMBER IN CIRCLE INDICATES POSITION OF STEEL POLE IN WIRE DIAGRAM. FOUNDATION DEPTH IS 6'.
-  PROP. LIGHT POLE, STEEL, 45' M.H., TWIN-TENON MT. WITH 2-250 WATT SODIUM VAPOR LUMINAIRES, MULTI-MOUNT. NUMBER IN CIRCLE INDICATES POSITION OF STEEL POLE IN WIRE DIAGRAM. LETTER INDICATES EACH LUMINAIRE ON POLE. FOUNDATION DEPTH IS 8'.
- 
-  PROP. CONTROL INSTALLATION, TYPE CB RCS 60/240

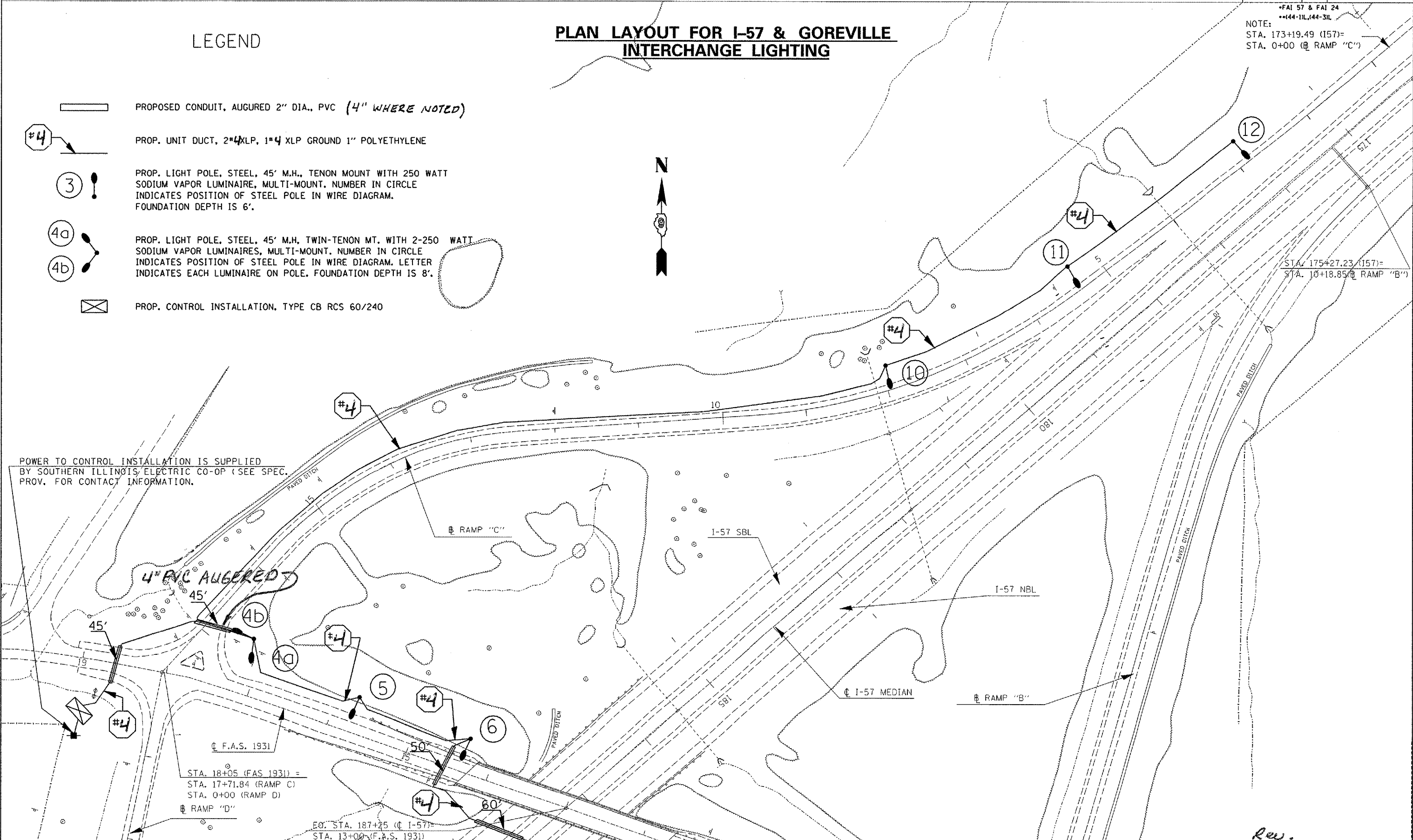

POWER TO CONTROL INSTALLATION IS SUPPLIED BY SOUTHERN ILLINOIS ELECTRIC CO-OP (SEE SPEC. PROV. FOR CONTACT INFORMATION).

4" PVC AUGERED

Rev.



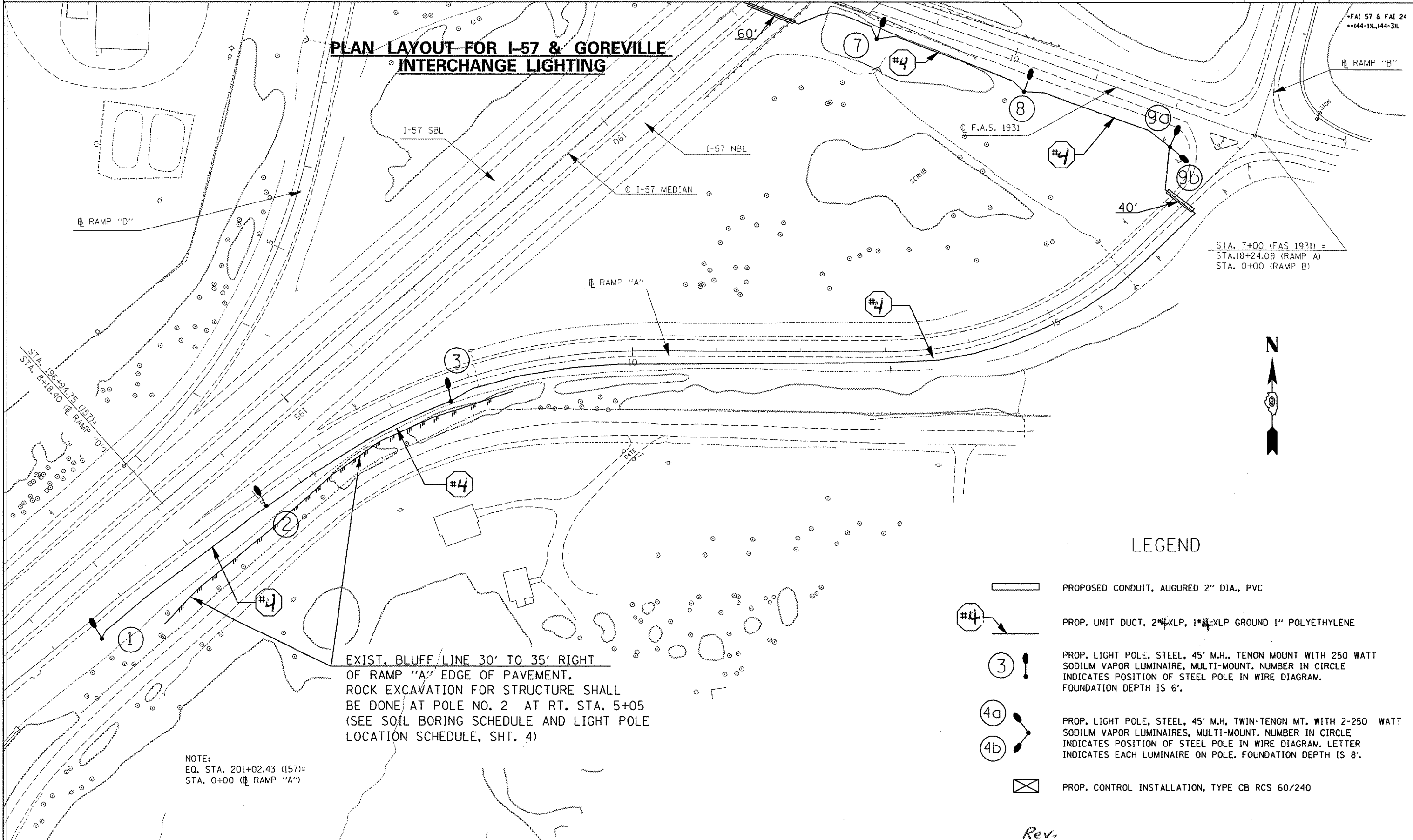

F.A.I. RTE.	SECTION	COUNTY	TOTAL SHEETS	SHEET NO.
---	---	JOHNSON	15	9
STA.	TO STA.			
FED. ROAD DIST. NO.	ILLINOIS	FED. AID PROJECT		

PLAN LAYOUT FOR I-57 & GOREVILLE INTERCHANGE LIGHTING



STA. 7+00 (FAS 1931) =
 STA. 18+24.09 (RAMP A)
 STA. 0+00 (RAMP B)

LEGEND

-  PROPOSED CONDUIT, AUGURED 2" DIA., PVC
-  PROP. UNIT DUCT, 2#4 XLP, 1#4 XLP GROUND 1" POLYETHYLENE
-  PROP. LIGHT POLE, STEEL, 45' M.H., TENON MOUNT WITH 250 WATT SODIUM VAPOR LUMINAIRE, MULTI-MOUNT. NUMBER IN CIRCLE INDICATES POSITION OF STEEL POLE IN WIRE DIAGRAM. FOUNDATION DEPTH IS 6'.
-  PROP. LIGHT POLE, STEEL, 45' M.H., TWIN-TENON MT. WITH 2-250 WATT SODIUM VAPOR LUMINAIRES, MULTI-MOUNT. NUMBER IN CIRCLE INDICATES POSITION OF STEEL POLE IN WIRE DIAGRAM. LETTER INDICATES EACH LUMINAIRE ON POLE. FOUNDATION DEPTH IS 8'.
-  PROP. CONTROL INSTALLATION, TYPE CB RCS 60/240

EXIST. BLUFF LINE 30' TO 35' RIGHT OF RAMP "A" EDGE OF PAVEMENT. ROCK EXCAVATION FOR STRUCTURE SHALL BE DONE AT POLE NO. 2 AT RT. STA. 5+05 (SEE SOIL BORING SCHEDULE AND LIGHT POLE LOCATION SCHEDULE, SHT. 4)

NOTE:
 EQ. STA. 201+02.43 (I57) =
 STA. 0+00 (RAMP "A")

F.A.I. RTE.	SECTION	COUNTY	TOTAL SHEETS	SHEET NO.
		JOHNSON	15	7
STA. _____		TO STA. _____		
FED. ROAD DIST. NO. _____		ILLINOIS FED. AID PROJECT _____		
*FAI 57 & FAI 24				
**44-1JL, 144-3JL				

PLAN LAYOUT FOR I-24 AND TUNNEL HILL INTERCHANGE LIGHTING



LEGEND

- PROPOSED CONDUIT, AUGURED 2" DIA., PVC
- PROP. UNIT DUCT, 2*6XLP, 1*6 XLP GROUND 1" POLYETHYLENE
- PROP. LIGHT POLE, STEEL, 45' M.H., TENON MOUNT WITH 250 WATT SODIUM VAPOR LUMINAIRE, MULTI-MOUNT. NUMBER IN CIRCLE INDICATES POSITION OF STEEL POLE IN WIRE DIAGRAM. FOUNDATION DEPTH IS 6'.
- PROP. LIGHT POLE, STEEL, 45' M.H., TWIN-TENON MT. WITH 2-250 WATT SODIUM VAPOR LUMINAIRE, MULTI-MOUNT. NUMBER IN CIRCLE INDICATES POSITION OF STEEL POLE IN WIRE DIAGRAM. LETTER INDICATES EACH LUMINAIRE ON POLE. FOUNDATION DEPTH IS 6'.
- PROP. CONTROL INSTALLATION, TYPE CB RCS 60/240

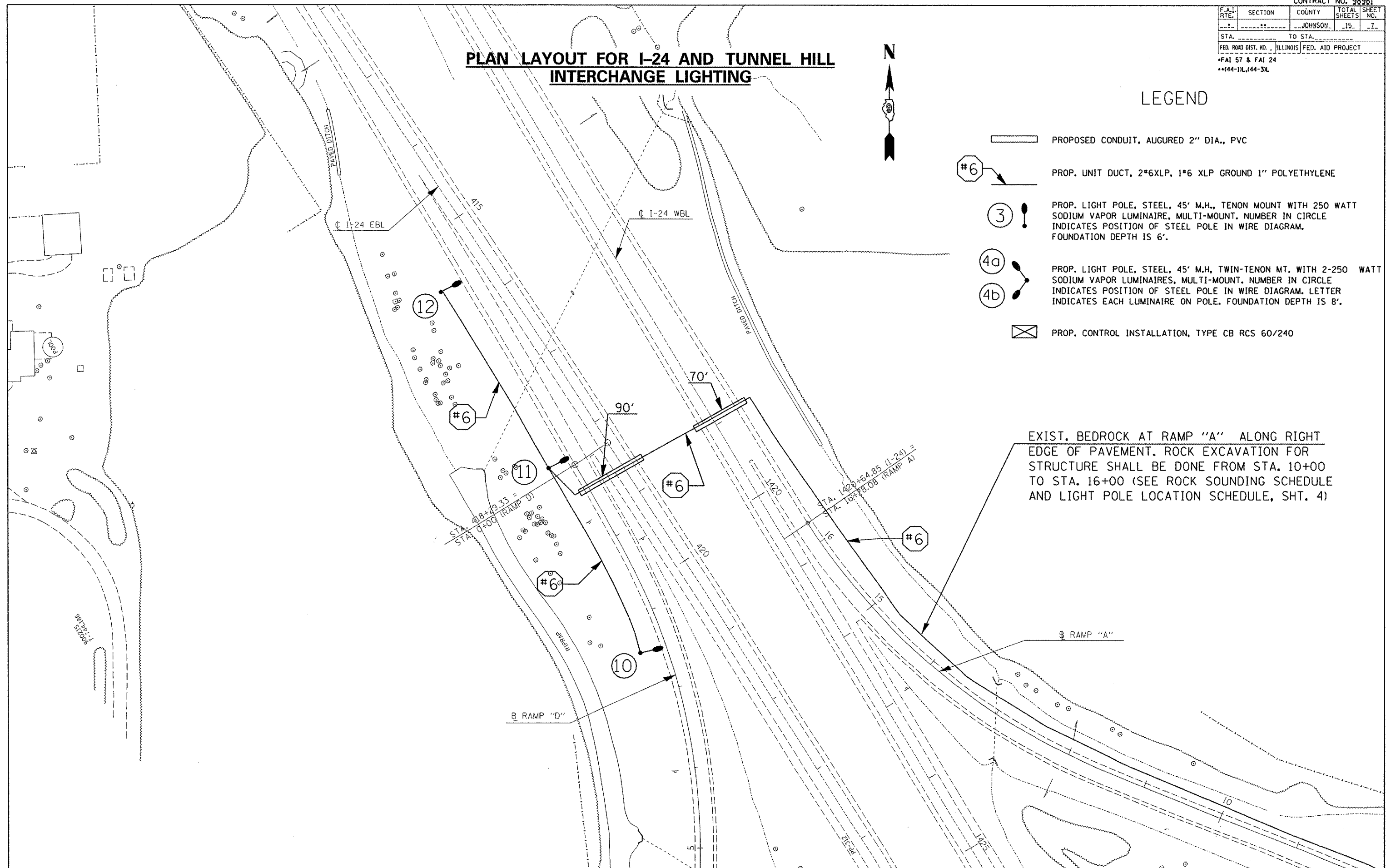

EXIST. BEDROCK AT RAMP "A" ALONG RIGHT EDGE OF PAVEMENT. ROCK EXCAVATION FOR STRUCTURE SHALL BE DONE FROM STA. 10+00 TO STA. 16+00 (SEE ROCK SOUNDING SCHEDULE AND LIGHT POLE LOCATION SCHEDULE, SHT. 4)

PLOT DATE = 8/22/2006
 FILE NAME = c:\projects\98981\124\12419.mxd
 PLOT SCALE = 1/8" = 100'-0"
 USER NAME = mcdonald

F.A.I. RTE.	SECTION	COUNTY	TOTAL SHEETS	SHEET NO.
..	..	JOHNSON	15	8
STA. _____ TO STA. _____		FED. ROAD DIST. NO. _____ ILLINOIS FED. AID PROJECT		
*FAI 57 & FAI 24		**44-1JL,44-3JL		

PLAN LAYOUT FOR I-24 AND TUNNEL HILL INTERCHANGE LIGHTING

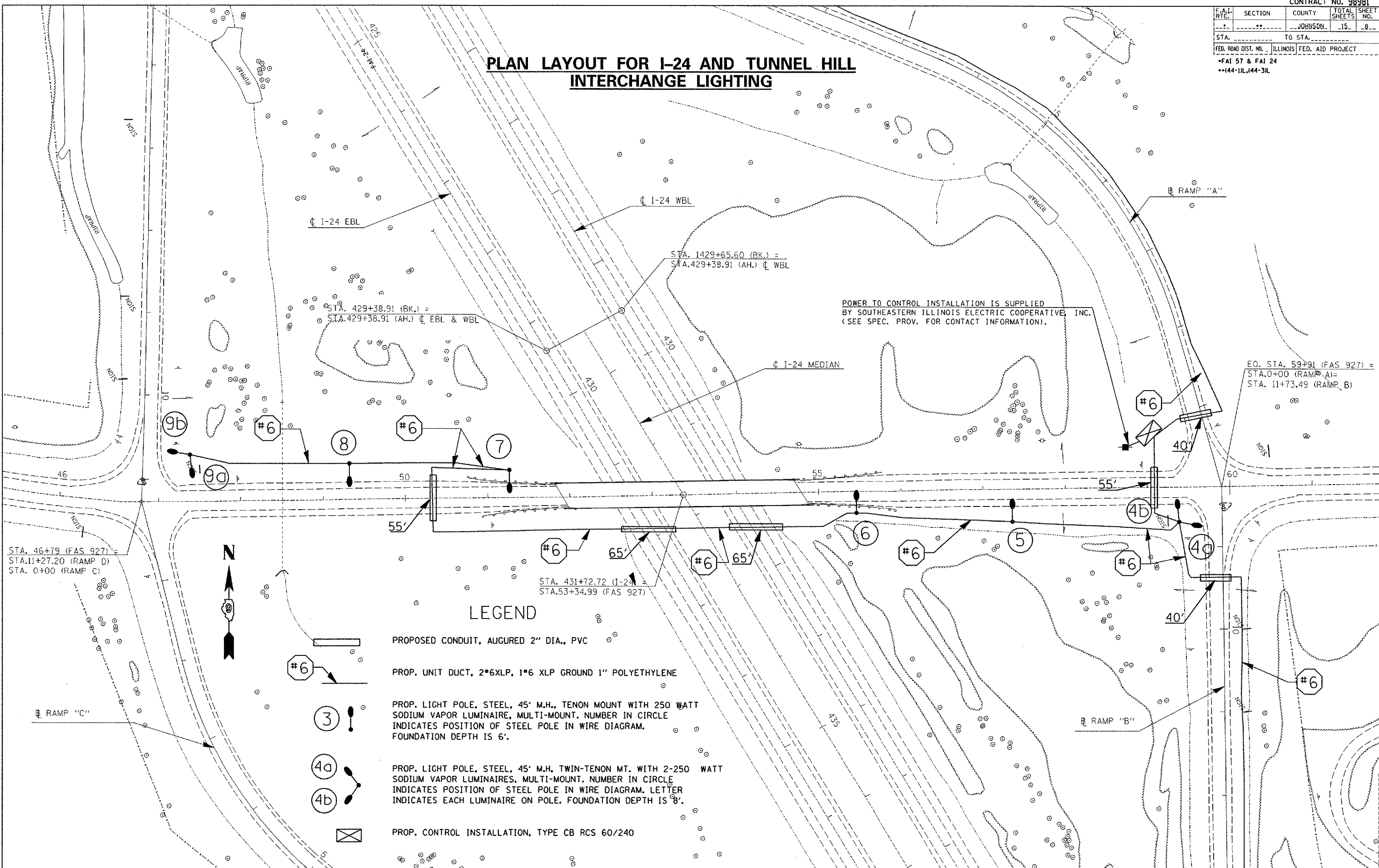





POWER TO CONTROL INSTALLATION IS SUPPLIED BY SOUTHEASTERN ILLINOIS ELECTRIC COOPERATIVE, INC. (SEE SPEC. PROV. FOR CONTACT INFORMATION).

EQ. STA. 59+91 (FAS 927) = STA. 0+00 (RAMP A) = STA. 11+73.49 (RAMP B)

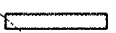
STA. 46+79 (FAS 927) = STA. 11+27.20 (RAMP D) = STA. 0+00 (RAMP C)

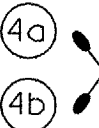
LEGEND

-  PROPOSED CONDUIT, AUGURED 2" DIA., PVC
-  PROP. UNIT DUCT, 2*6XLP, 1*6 XLP GROUND 1" POLYETHYLENE
-  PROP. LIGHT POLE, STEEL, 45' M.H., TENON MOUNT WITH 250 WATT SODIUM VAPOR LUMINAIRE, MULTI-MOUNT. NUMBER IN CIRCLE INDICATES POSITION OF STEEL POLE IN WIRE DIAGRAM. FOUNDATION DEPTH IS 6'.
-  PROP. LIGHT POLE, STEEL, 45' M.H. TWIN-TENON MT. WITH 2-250 WATT SODIUM VAPOR LUMINAIRES, MULTI-MOUNT. NUMBER IN CIRCLE INDICATES POSITION OF STEEL POLE IN WIRE DIAGRAM. LETTER INDICATES EACH LUMINAIRE ON POLE. FOUNDATION DEPTH IS 8'.
-  PROP. CONTROL INSTALLATION, TYPE CB RCS 60/240

PLOT DATE = 8/22/2005
 FILE NAME = c:\arcwork\1049086\157-1241g.mxd
 PLOT SCALE = 1/8" = 1' IN.
 USER NAME = mscorckr





F.A.I. RTE.	SECTION	COUNTY	TOTAL SHEETS	SHEET NO.
..JOHNSON..	..15..	..9..
STA.		TO STA.		
FED. ROAD DIST. NO. ... ILLINOIS FED. AID PROJECT				

PLAN LAYOUT FOR I-24 AND TUNNEL HILL INTERCHANGE LIGHTING

*FAI 57 & FAI 24
**44-11L, 44-31L

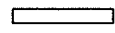

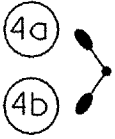
LEGEND

-  PROPOSED CONDUIT, AUGURED 2" DIA., PVC
-  PROP. UNIT DUCT, 2*6XLP, 1*6 XLP GROUND 1" POLYETHYLENE
-  PROP. LIGHT POLE, STEEL, 45' M.H., TENON MOUNT WITH 250 WATT SODIUM VAPOR LUMINAIRE, MULTI-MOUNT. NUMBER IN CIRCLE INDICATES POSITION OF STEEL POLE IN WIRE DIAGRAM. FOUNDATION DEPTH IS 6'.
-  PROP. LIGHT POLE, STEEL, 45' M.H., TWIN-TENON MT. WITH 2-250 WATT SODIUM VAPOR LUMINAIRES, MULTI-MOUNT. NUMBER IN CIRCLE INDICATES POSITION OF STEEL POLE IN WIRE DIAGRAM. LETTER INDICATES EACH LUMINAIRE ON POLE. FOUNDATION DEPTH IS 8'.
-  PROP. CONTROL INSTALLATION, TYPE CB RCS 60/240

PLOT DATE = 8/22/2008
 FILE NAME = c:\projects\98981\98981.dwg
 PLOT SCALE = 1/8" = 1'-0"
 USER NAME = mcdonald

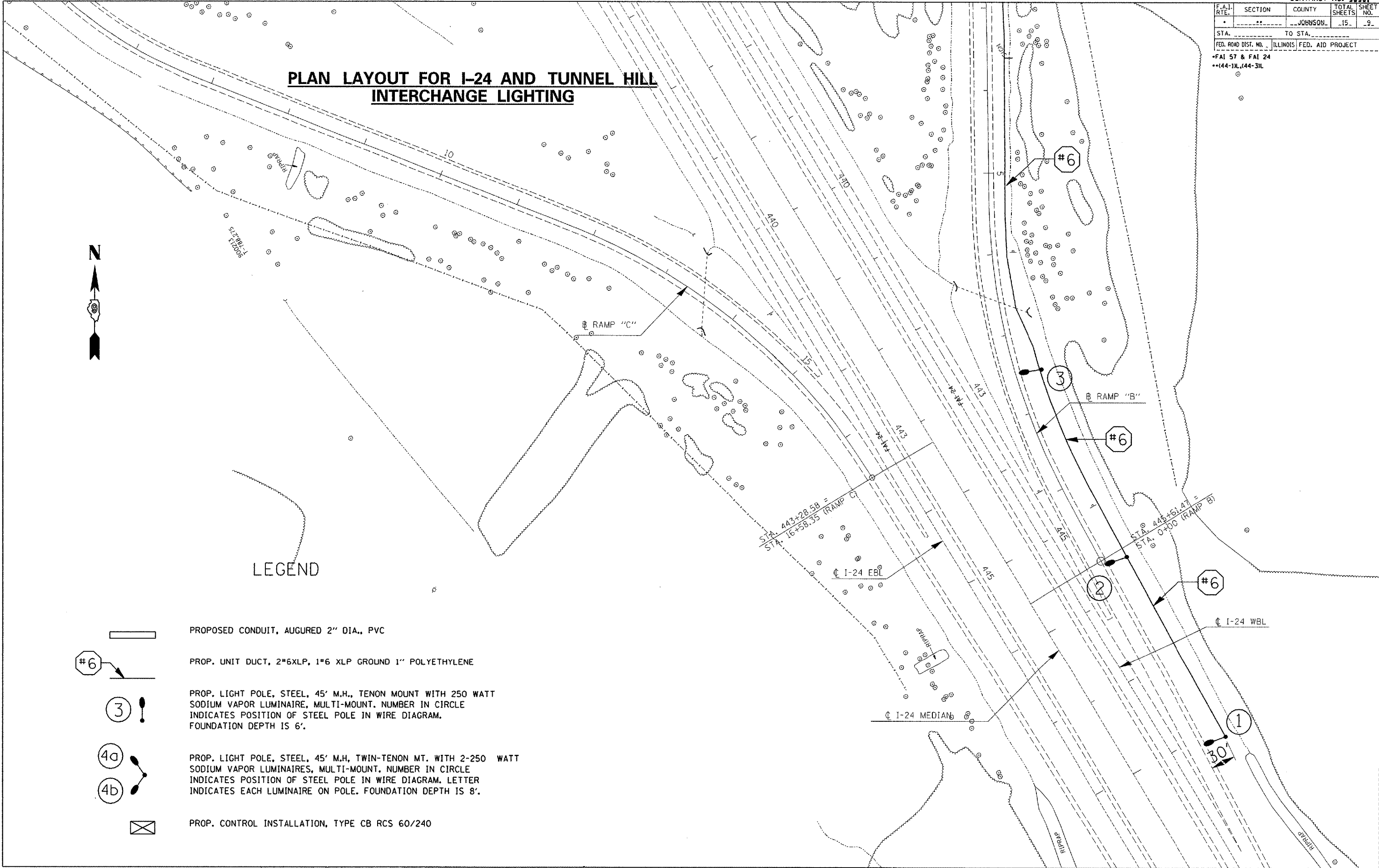

LOCATION 2 - I-24 AND TUNNEL HILL INTERCHANGE LIGHT POLE PLAN LAYOUT - SOUTH OF INTERCHANGE

F.A.I. NO.	SECTION	COUNTY	TOTAL SHEETS	SHEET NO.
.	..	JOHNSON	15	10

STA.	TO STA.
FED. ROAD DIST. NO. ILLINOIS	FED. AID PROJECT

*FAI 57 & FAI 24
 **44-11L, 44-3L

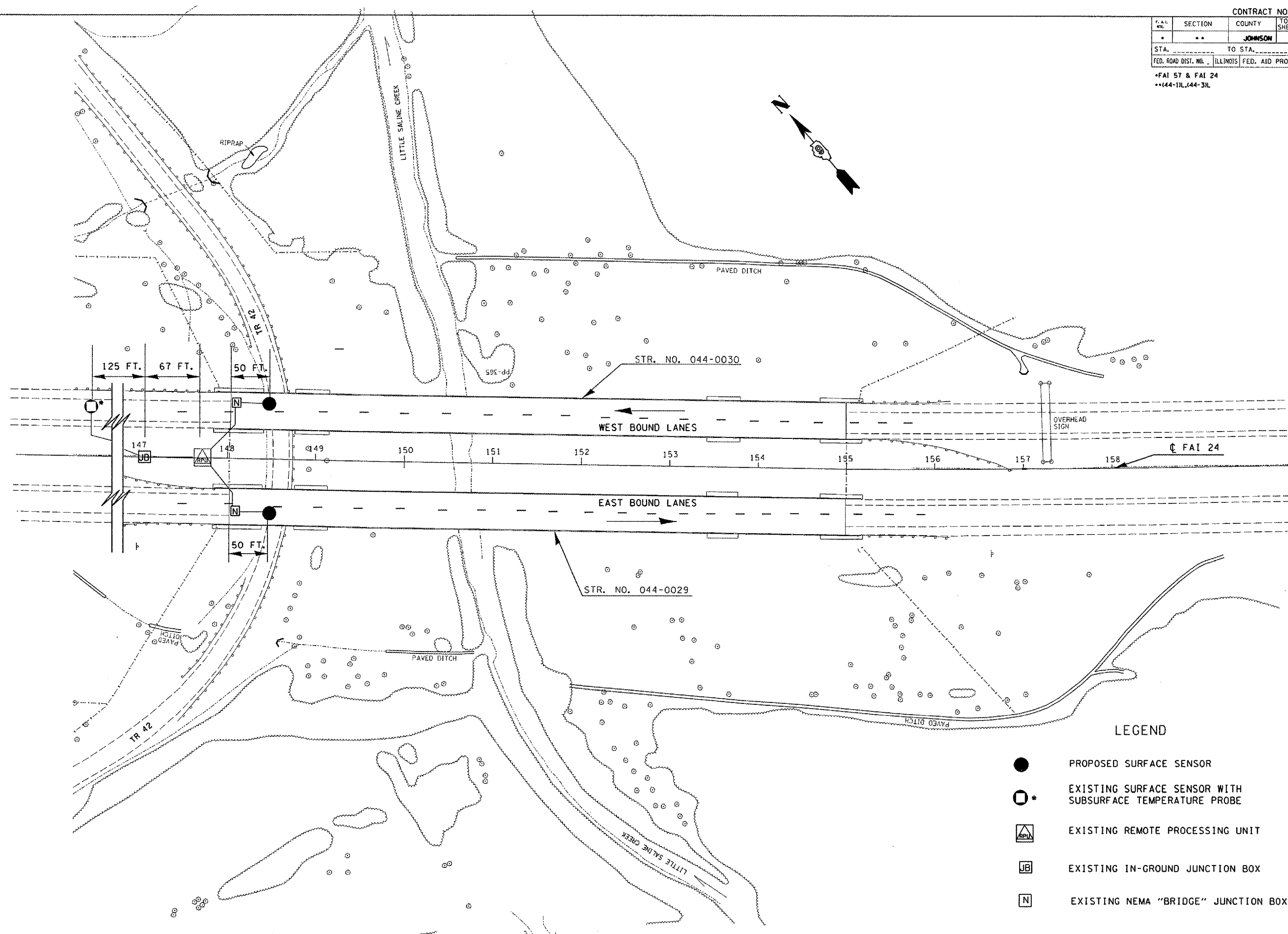

LEGEND

- PROPOSED SURFACE SENSOR
- * EXISTING SURFACE SENSOR WITH SUBSURFACE TEMPERATURE PROBE
- △ RPU EXISTING REMOTE PROCESSING UNIT
- JB EXISTING IN-GROUND JUNCTION BOX
- N EXISTING NEMA "BRIDGE" JUNCTION BOX

PLOT DATE = 8/22/2005
 FILE NAME = c:\projects\98981\57-241\plan32
 PLOT SCALE = 1/8"=1'-0"
 USER NAME = mcdonald

SECTION	COUNTY	TOTAL SHEETS	SHEET NO.
..	JOHNSON	15	11

STA. TO STA.
 FED. ROAD DIST. NO. ILLINOIS FED. AID PROJECT
 *FAI 57 & FAI 24
 **44-31L, 44-31L

PLAN LAYOUT FOR I-24 AND US 45 INTERCHANGE LIGHTING AT VIENNA

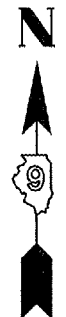

LEGEND

- # EXISTING LIGHT POLE *TO REMAIN*
- ⊠ EXISTING LIGHTING CONTROLLER *TO REMAIN*
- ▭ PROPOSED CONDUIT, AUGURED 2", PVC
- - - EXISTING UNIT DUCT TO REMAIN IN PLACE (*EXCEPT WHERE NOTED*)
- #6 PROPOSED UNIT DUCT, 2 *6XLP, 1 *6 XLP GROUND 1" POLYETHYLENE

NOTES

- NOTE 1: ROCK HAS BEEN OBSERVED IN THIS AREA. ROCK EXCAVATION FOR STRUCTURES IS CALCULATED FOR THE TRENCHING OF THE UNIT DUCT ALONG FAI 24 NEAR LIGHT POLE #14.
- NOTE 2: EXISTING CABLE AND CONDUIT FROM EXISTING LIGHTING CONTROLLER TO EX. LIGHT POLE NO. 15 ON EXIT RAMP "B" SHALL BE ABANDONED WHEN PROPOSED UNIT DUCT AND CONDUIT ARE INSTALLED. SEE WIRING DIAGRAM, SHT. 12.

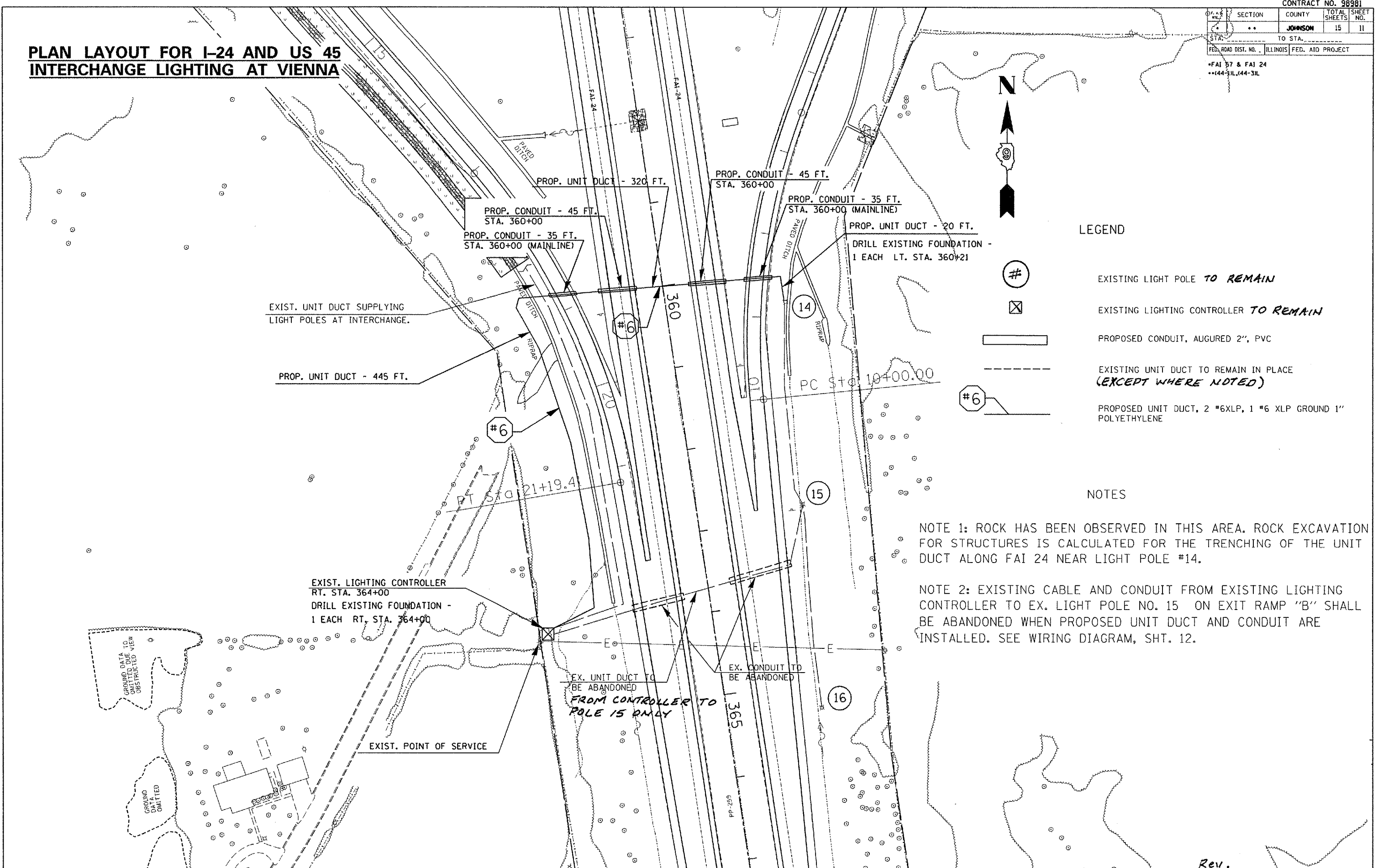

PLOT DATE : 8/23/2006
 FILE NAME : c:\projects\98981\98981-12411g.mxd
 PLOT SCALE : 1/8" = 1'-0"
 USER NAME : mccordk

Rev.

F.A.I. RTE.	SECTION	COUNTY	TOTAL SHEETS	SHEET NO.
..	..	JOHNSON	15	12
STA.	TO STA.			
FED. ROAD DIST. NO. ..		ILLINOIS	FED. AID PROJECT	

*FAI 57 & FAI 24
 **144-11L, 144-3L

WIRING DIAGRAM FOR I-57 & GOREVILLE INTERCHANGE LIGHTING

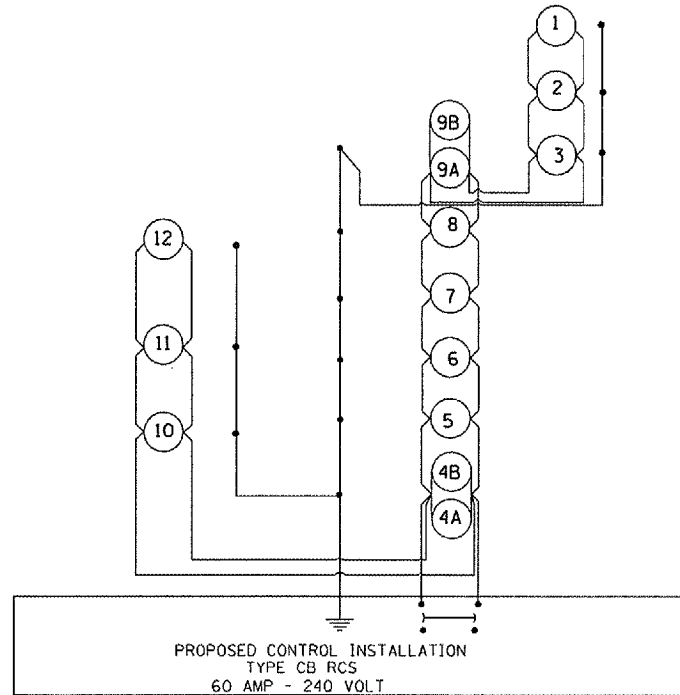

NOTES:

- FOR SIZE AND TYPE OF CABLE USED FOR LIGHTING INSTALLATION SEE CABLE DIAGRAM SHEET NO. 5-6.
- POWER TO CONTROL INSTALLATION IS SUPPLIED BY SOUTHERN ILLINOIS ELECTRIC CO-OP (SEE SPEC. PROV. FOR CONTACT INFORMATION).

LEGEND FOR WIRING DIAGRAM

- ① NUMBER INDICATES POSITION OF POLE IN WIRING DIAGRAM.
- ④A NUMBER INDICATES POSITION OF POLE IN WIRING DIAGRAM. LETTER INDICATES TWIN-TENON MOUNTED LUMINAIRE.
- INDICATES PROPOSED GROUND AT LIGHT POLE AND CONTROL INSTALLATION.
- ⊥ INDICATES CONTINUOUS GROUND FROM CONTROL INSTALLATION.

REVISIONS	
DRAWN	7-27-93
REVISED	5-14-02
REVISED
REVISED

STD. 9-59

WIRING DIAGRAM FOR I-24 AND TUNNELL HILL INTERCHANGE LIGHTING

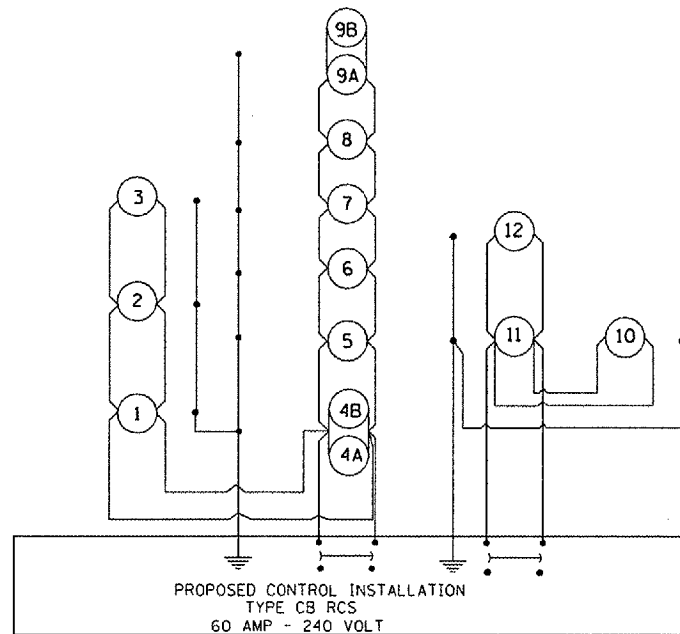

NOTES:

- FOR SIZE AND TYPE OF CABLE USED FOR LIGHTING INSTALLATION SEE CABLE DIAGRAM SHEET NO. 7-9.
- POWER TO CONTROL INSTALLATION IS SUPPLIED BY SOUTHEASTERN ILLINOIS ELECTRIC COOPERATIVE, INC. (SEE SPEC. PROV. FOR CONTACT INFORMATION).

LEGEND FOR WIRING DIAGRAM

- ① NUMBER INDICATES POSITION OF POLE IN WIRING DIAGRAM.
- ④A NUMBER INDICATES POSITION OF POLE IN WIRING DIAGRAM. LETTER INDICATES TWIN-TENON MOUNTED LUMINAIRE.
- INDICATES PROPOSED GROUND AT LIGHT POLE AND CONTROL INSTALLATION.
- ⊥ INDICATES CONTINUOUS GROUND FROM CONTROL INSTALLATION.

REVISIONS	
DRAWN	7-27-93
REVISED	5-14-02
REVISED
REVISED

STD. 9-59

WIRING DIAGRAM FOR I-24 AND US 45 AT VIENNA EXISTING INTERCHANGE LIGHTING

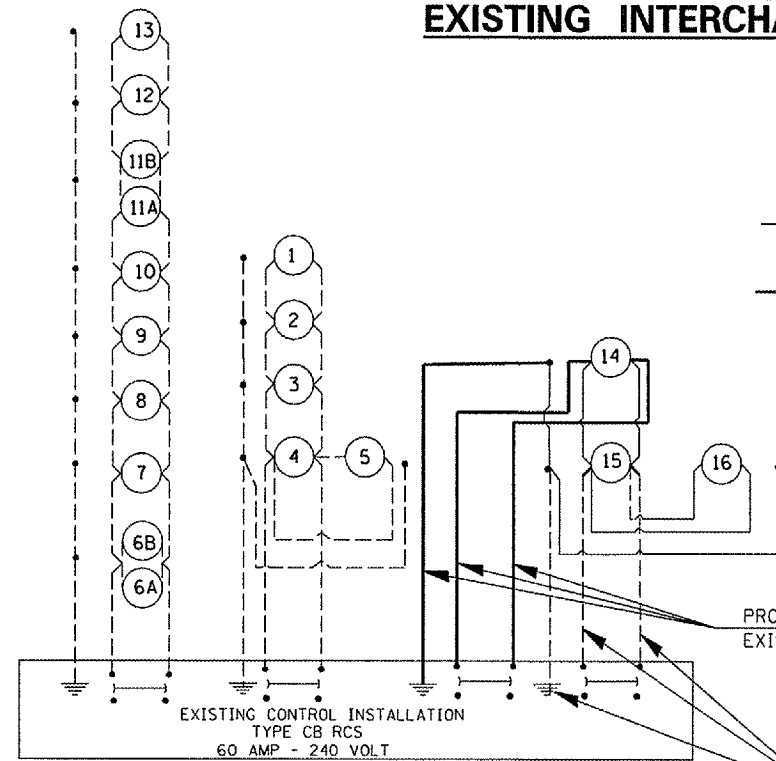

LEGEND FOR WIRING DIAGRAM

- EXISTING UNIT DUCT TO EXISTING LIGHT POLES
- PROPOSED UNIT DUCT TO EXISTING LIGHT POLE 14 FROM EXISTING LIGHTING CONTROLLER
- EXISTING UNIT DUCT FROM POLE 14 THRU POLE 15 TO POLE 16 TO REMAIN
- ① NUMBER INDICATES POSITION OF POLE IN WIRING DIAGRAM.
- ④A NUMBER INDICATES POSITION OF POLE IN WIRING DIAGRAM. LETTER INDICATES TWIN-TENON MOUNTED LUMINAIRE.
- INDICATES PROPOSED GROUND AT LIGHT POLE AND CONTROL INSTALLATION.
- ⊥ INDICATES CONTINUOUS GROUND FROM CONTROL INSTALLATION.
- PROP. UNIT DUCT #6 TO REPLACE EXIST. UNIT DUCT
- EXIST. UNIT DUCT #6 TO BE ABANDONED FROM EX. CONTROLLER TO EX. LIGHT POLE #15.

Rev.

PLOT DATE = 8/22/2005
 FILE NAME = c:\projects\98981\I-24\12.dwg
 PLOT SCALE = 1/8"=1'-0"
 USER NAME = mcdonald

F.A.I. RY.	SECTION	COUNTY	TOTAL SHEETS	SHEET NO.
---	---	JOHNSON	15	13
STA. _____ TO STA. _____				
FED. ROAD DIST. NO. ILLINOIS FED. AID PROJECT				

*FAI 57 & FAI 24
**44-1L, 44-3L

POLE STANDARDS

"INSTALL AND ORIENT ARM BRACKET OVER POLE TENON AND FIRMLY HAND TIGHTEN THE TWO SET SCREWS. USE THIRD HOLE IN ARM BRACKET AS A GUIDE TO DRILL A 3/8" DIAMETER HOLE THROUGH TENON. INSTALL AND TIGHTEN SELF-TAPPING SCREW. TIGHTEN SET SCREWS AN ADDITIONAL 1/4 TO 3/8 TURN WITH HEX KEY (NOT PROVIDED). INSTALL LOCKNUTS ON SET SCREWS IF THREADED PROJECTION ALLOWS."

POLE SHALL MEET AASHTO STANDARD SPECIFICATIONS FOR 80 MPH WIND LOADING AND 90 LB, 4.0 SQ. FT E.P.A. LUMINAIRE.

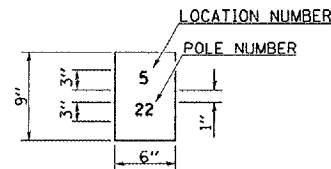

THE CONTRACTOR SHALL FURNISH AND INSTALL A LIGHT POLE IDENTIFICATION OF EACH NEW LIGHT POLE, AS SHOWN ABOVE, INCIDENTAL TO THE RESPECTIVE LIGHT POLE PAY ITEM. THE NUMERALS SHALL BE 3", SERIES "D", BLACK, SCREENED ON SILVER-WHITE TYPE B PRESSURE SENSITIVE REFLECTIVE SHEETING CONFORMING TO THE REQUIREMENTS OF SECTION T602.01 OF THE STANDARD SPECIFICATIONS FOR TRAFFIC CONTROL ITEMS. THE NUMERALS SHALL CONFORM TO THE FHWA "STANDARD ALPHABETS FOR HIGHWAY SIGNS".

THE LIGHT POLE IDENTIFICATION SHALL BE APPLIED TO SIGN BASE MATERIAL AS SPECIFIED IN SECTION 719.11 OF THE STANDARD SPECIFICATIONS, APPROXIMATELY 7" ABOVE THE ADJACENT PAVEMENT GRADE VISIBLE TO APPROACHING TRAFFIC IN ACCORDANCE WITH HIGHWAY STANDARD 2319.

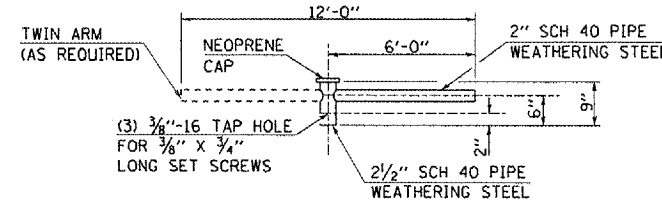
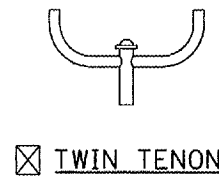

NOTE: SINGLE OR TWIN ARM ASSEMBLY SHALL BE TILTED 3° ABOVE HORIZONTAL.

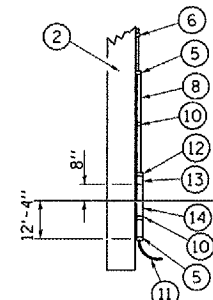
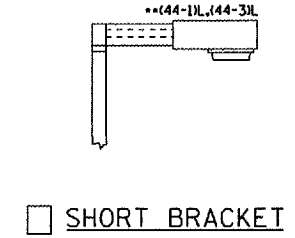
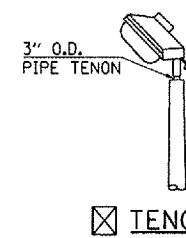
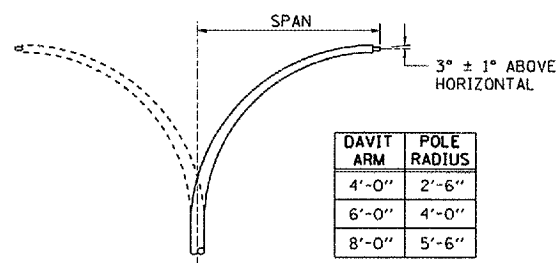

POLE LENGTH	DEPTH IN GROUND
65'-0"	12'-0"
60'-0"	10'-0"
55'-0"	9'-0"
50'-0"	8'-0"
45'-0"	7'-0"
40'-0"	6'-6"
35'-0"	6'-0"
30'-0"	5'-6"

DETAILS FOR UNDERGROUND DISTRIBUTION IF REQUIRED

POLE, WOOD

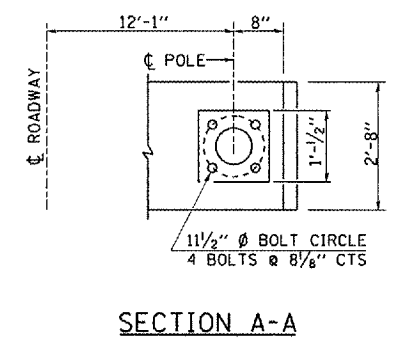
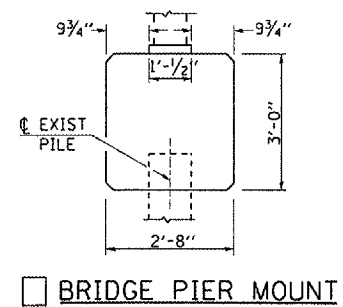
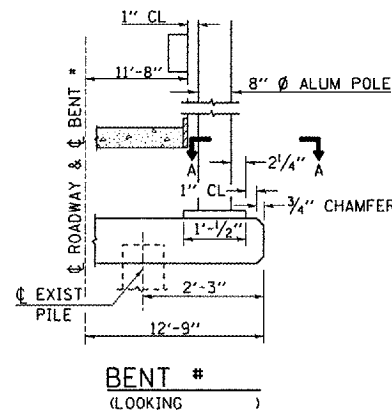
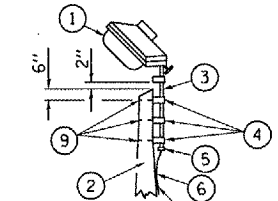
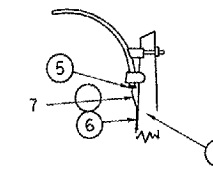

- ① LUMINAIRE
- ② WOOD POLE, CLASS 3 OR BETTER
- ③ 2 1/2" GALV. STEEL CONDUIT
- ④ SINGLE OFFSET POLE BAND
- ⑤ CONDUIT BUSHING
- ⑥ CABLE CLAMPS ON 2" CENTERS
- ⑦ 2/C #12 TYPE USE CABLE
- ⑧ 1" GALV. STEEL CONDUIT 10' IN LENGTH

- ⑨ 5/8" Ø HOT DIPPED GALVANIZED BOLT WITH FLAT WASHER & LOCKNUT (3 REQ'D)
- ⑩ CONDUIT CLAMPS ON 3' CENTERS
- ⑪ UNIT DUCT
- ⑫ THREADED REDUCER
- ⑬ "C" CONDULET, THREADED
- ⑭ 1 1/2" GALV. STEEL CONDUIT FOR 1 UNIT DUCT OR 3" GALV. STEEL CONDUIT FOR 2 OR 3 UNIT DUCTS.

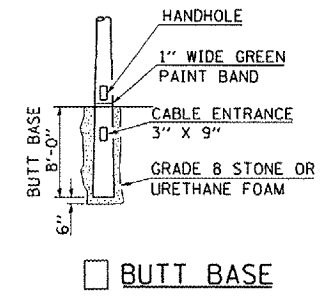
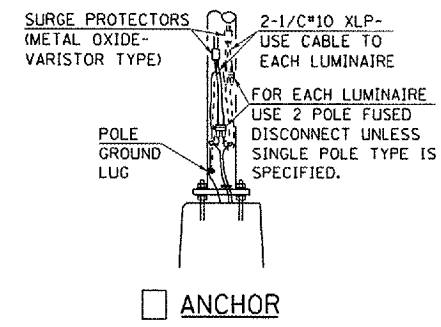
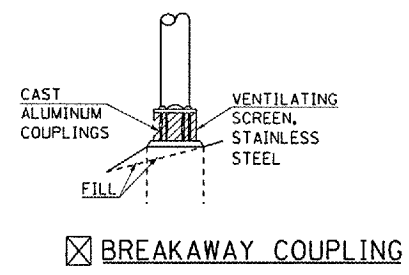
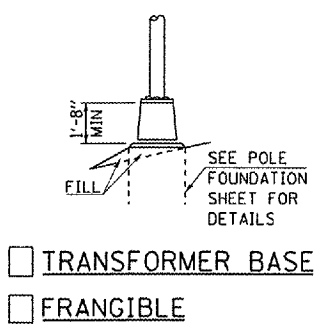
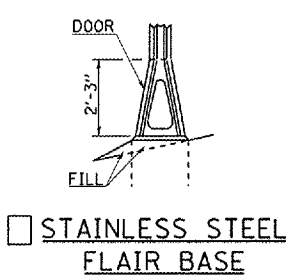

PLOT DATE: 6/7/2006
 FILE NAME: c:\p\projects\080805\07-241\p\02
 USER: m...
 USER NAME: m...

REVISIONS	DATE
DRAWN	2-9-00
REVISED	4-18-00
REVISED	

LIGHT POLE MOUNTING HEIGHT	STEEL FOUNDATION				CONCRETE FOUNDATION		
	BOLT CIRCLE DIAMETER	SHAFT DIAMETER	SHAFT DEPTH	TOP PLATE (min)	SHAFT DIAMETER	SHAFT DEPTH	ANCHOR ROD LENGTH (1)
<9.1 m (30')	292 (11.5)	220 (8 5/8)	1.83 m (6')	300 x 300 x 25 12 x 12 x 1	610 (24)	1.52 m (5'-0")	1.45 m (4'-9")
9.4 m - 10.7 m (31'-35')	292 (11.5)	220 (8 5/8)	1.83 m (6')	300 x 300 x 25 12 x 12 x 1	610 (24)	1.67 m (5'-6")	1.60 m (5'-3")
10.9 m - 12.2 m (36'-40')	381 (15) (3)	220 (8 5/8)	1.83 m (6') (2)	375 x 375 x 31 15 x 15 x 1 1/4	762 (30)	1.83 m (6'-0")	1.75 m (5'-9")
12.5 m - 13.7 m (41'-45')	381 (15) (3)	220 (8 5/8)	1.83 m (6') (2)	375 x 375 x 31 15 x 15 x 1 1/4	762 (30)	1.98 m (6'-6")	1.90 m (6'-3")
14.0 m - 15.2 m (46'-50')	381 (15) (3)	220 (8 5/8)	2.44 m (8')	375 x 375 x 31 15 x 15 x 1 1/4	762 (30)	2.13m (7'-0")	2.00 m (6'-9")

- (1) Length does not include 100(4)hook
- (2) 220 mm x 2.44 m (8 5/8" x 8'-0") for Twin luminaires
- (3) Bolt circle diam. shall be 430 (17) when a TB3-17 transformer base is used

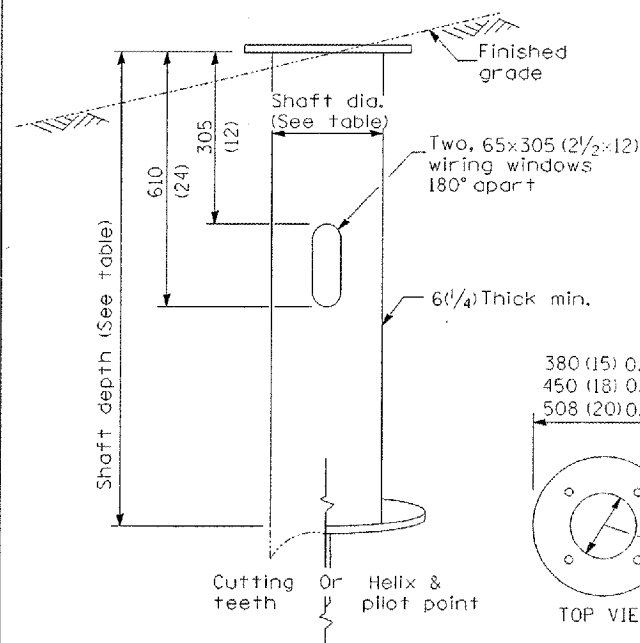
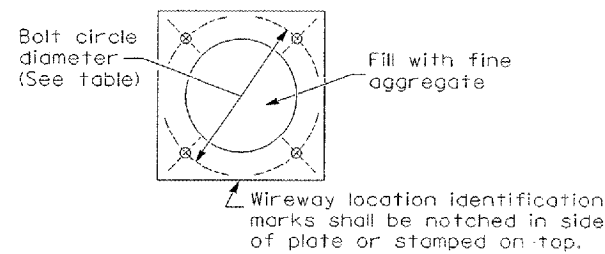

STEEL FOUNDATION

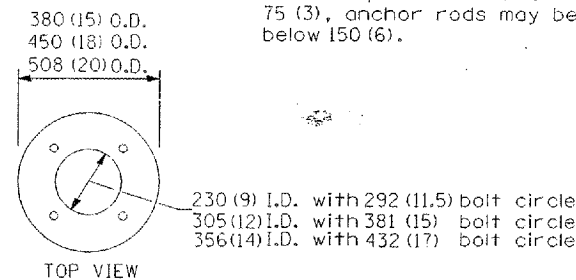

RING PLATE DETAIL

(When rock is encountered and foundation is shallower)

Length above foundation shall be adjusted to accommodate breakaway devices furnished by the contractor for a specific installation.

Use dirt removed from foundation to meet 1.52m (5 ft.) chord fill around foundation top. Grade dirt level with bottom of concrete chamfer.

- (4) If the required anchor rod length above top of foundation is less than 75 (3), anchor rods may be lowered below 150 (6).

Cast bronze clamp
16 mm x 3 m (5/8" x 10')
Copperclad grounding electrode. When foundation is set in rock, install ground electrode in cable trench.

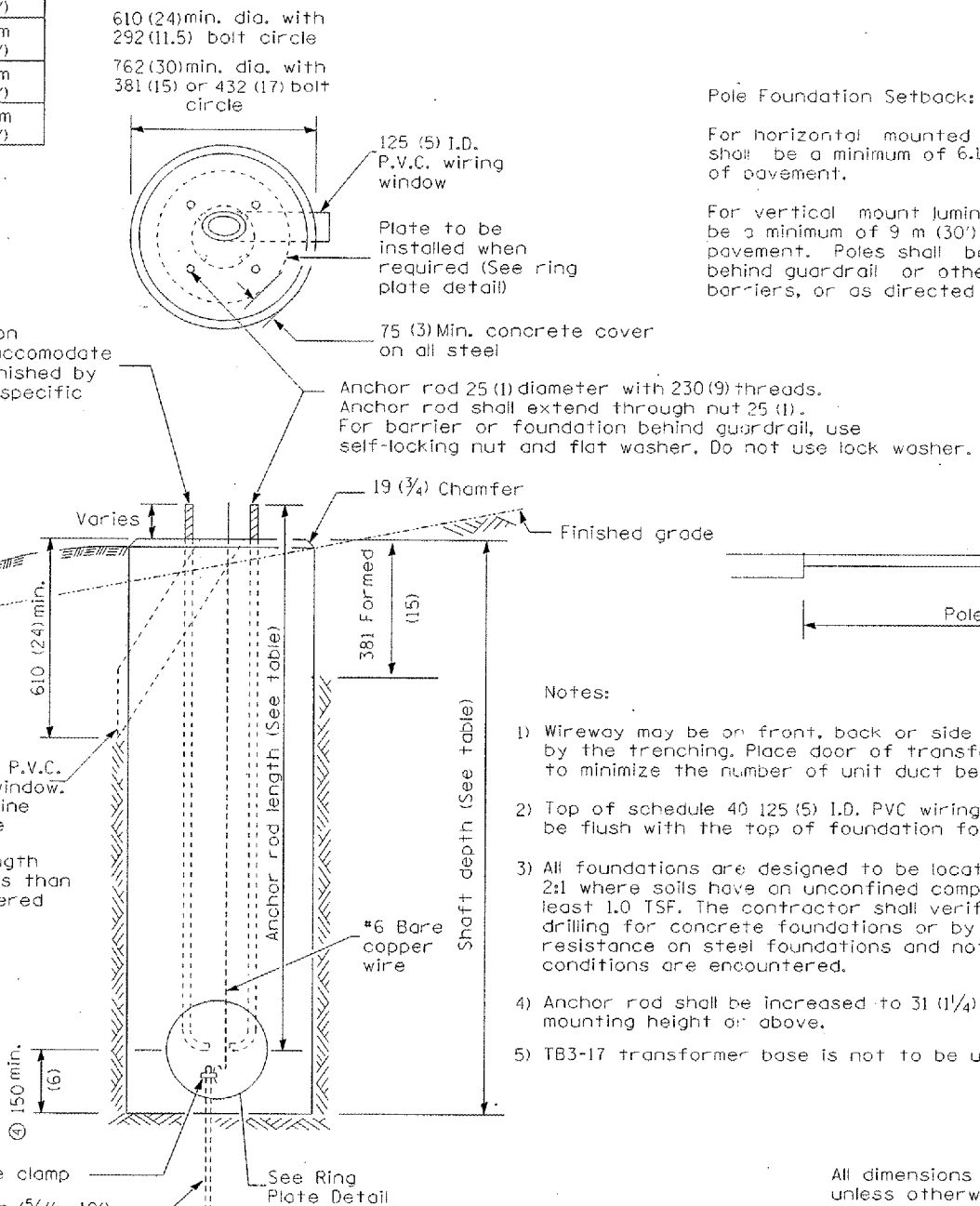

CONCRETE FOUNDATION

Pole Foundation Setback:

For horizontal mounted luminaires, setback shall be a minimum of 6.1 m (20') from edge of pavement.

For vertical mount luminaires, setback shall be a minimum of 9 m (30') from edge of pavement. Poles shall be located 1.5 m (5') behind guardrail or other protective barriers, or as directed by the Engineer.

Notes:

- 1) Wireway may be on front, back or side of foundation as required by the trenching. Place door of transformer base on wireway side to minimize the number of unit duct bends.
- 2) Top of schedule 40 125 (5) I.D. PVC wiring window, shall be flush with the top of foundation for drainage.
- 3) All foundations are designed to be located on slopes not exceeding 2:1 where soils have an unconfined compressive strength of at least 1.0 TSF. The contractor shall verify the soil strength during drilling for concrete foundations or by monitoring installation resistance on steel foundations and notify the engineer if other conditions are encountered.
- 4) Anchor rod shall be increased to 31 (1 1/4) diameter for 15.24 (50') mounting height or above.
- 5) TB3-17 transformer base is not to be used on metal foundation

All dimensions are in millimeters (inches) unless otherwise shown.

DATE	REVISIONS
10/7/02	Bridge Office depth calc.

LIGHT POLE FOUNDATION

LGT007-836

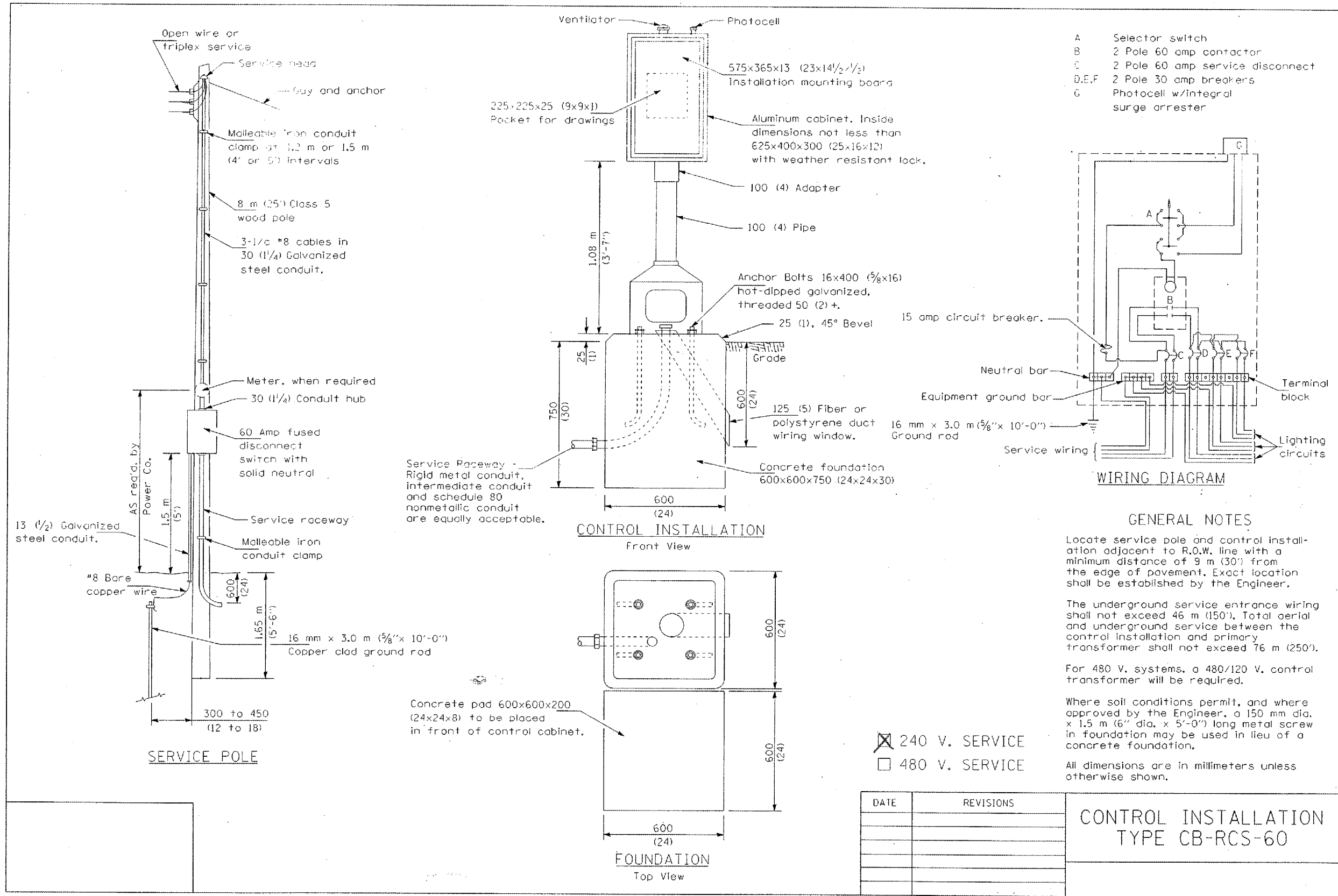

WIRING DIAGRAM

GENERAL NOTES

Locate service pole and control installation adjacent to R.O.W. line with a minimum distance of 9 m (30') from the edge of pavement. Exact location shall be established by the Engineer.

The underground service entrance wiring shall not exceed 46 m (150'). Total aerial and underground service between the control installation and primary transformer shall not exceed 76 m (250').

For 480 V. systems, a 480/120 V. control transformer will be required.

Where soil conditions permit, and where approved by the Engineer, a 150 mm dia. x 1.5 m (6" dia. x 5'-0") long metal screw in foundation may be used in lieu of a concrete foundation.

All dimensions are in millimeters unless otherwise shown.

DATE	REVISIONS

CONTROL INSTALLATION
TYPE CB-RCS-60

LGT006.M32