

F.A.U. RTE.	SECTION	COUNTY	TOTAL SHEETS	SHEET NO.
2298	13-00215-30-PV	KANE	177	1
		ILLINOIS	CONTRACT NO. 61D16	

INDEX OF SHEETS 11-17-2017 LETTING ITEM 052

FOR INDEX OF SHEETS, SEE SHEET NO. 2

STATE OF ILLINOIS DEPARTMENT OF TRANSPORTATION

PLANS FOR PROPOSED FEDERAL-AID HIGHWAY

**FAU 2298 (LONGMEADOW PARKWAY)
EAST OF IL ROUTE 25 TO IL ROUTE 62
ROADWAY CORRIDOR CONSTRUCTION
SECTION 13-00215-30-PV
KANE COUNTY
C-91-066-15**



DESIGN DESIGNATION

**LONGMEADOW PARKWAY: MINOR ARTERIAL 5.36 (PCC-20)
POSTED SPEED: 40 MPH
DESIGN SPEED: 50 MPH
ADT: 8,000 (2040)
ADTT: 320 (2040)
DHV: 640 (2040)**

**TRAFFIC COMPOSITION:
P.V. - 97.0%
S.U. - 2.0%
M.U. - 1.0%**

**IL ROUTE 62: OTHER PRINCIPAL ARTERIAL 10.05 (PCC-20)
POSTED SPEED: 55 MPH
DESIGN SPEED: 60 MPH
ADT: 31,000 (2040)
ADTT: 1,240 (2040)
DHV: 2,550 (2040)**

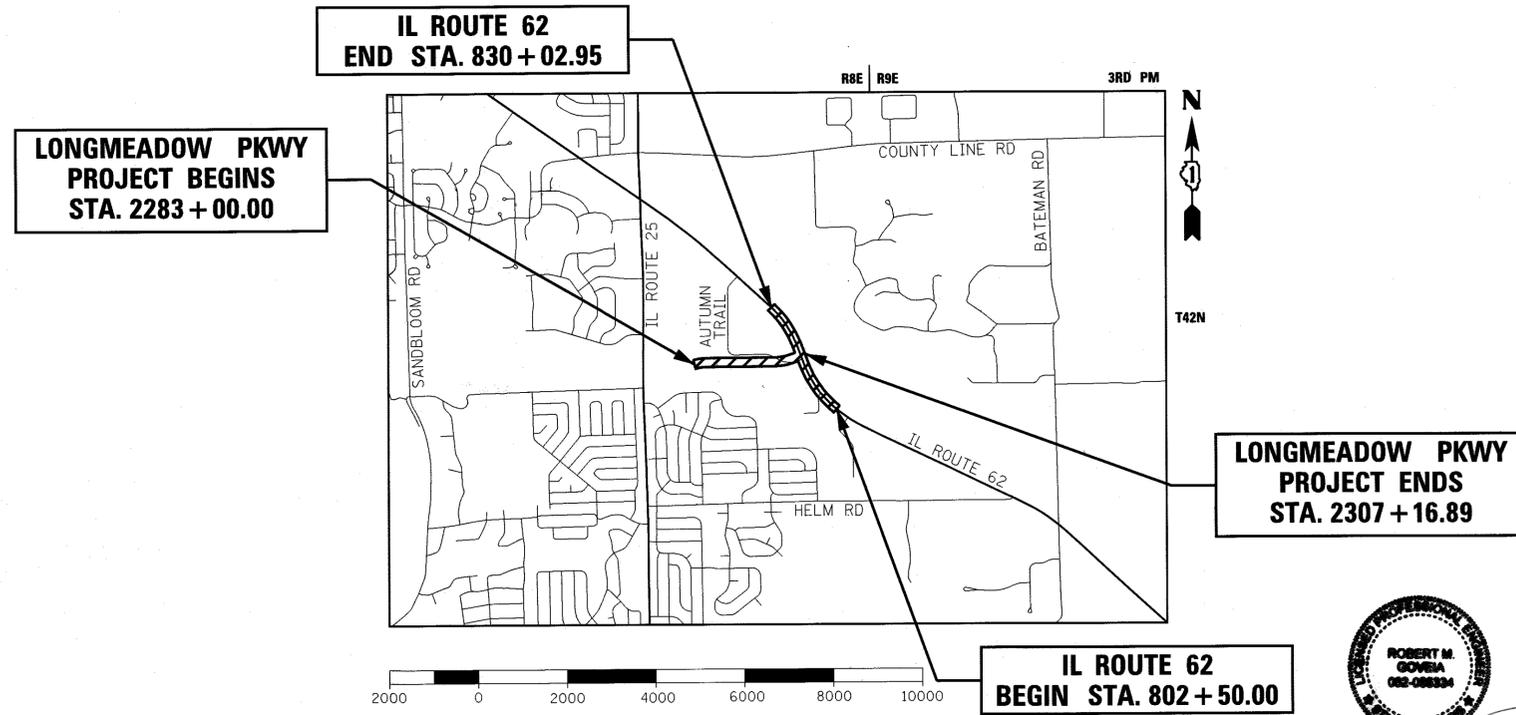

PROJECT IS LOCATED IN THE VILLAGE OF BARRINGTON HILLS & VILLAGE OF CARPENTERSVILLE

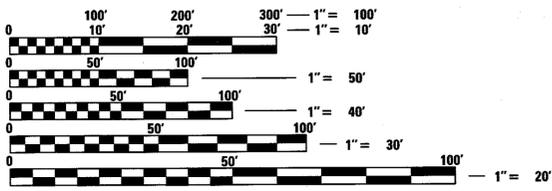

FULL SIZE PLANS HAVE BEEN PREPARED USING STANDARD ENGINEERING SCALES. REDUCED SIZED PLANS WILL NOT CONFORM TO STANDARD SCALES. IN MAKING MEASUREMENTS ON REDUCED PLANS, THE ABOVE SCALES MAY BE USED.

J.U.L.I.E.
JOINT UTILITY LOCATION INFORMATION FOR EXCAVATION
1-800-892-0123

**BURNS
MEDONNELL**
200 W. ADAMS STREET / SUITE 1600
CHICAGO, IL 60606
P: (312)-223-0920 / F: (312)-223-8664
WEB: WWW.BURNSMCD.COM

LONGMEADOW PARKWAY = 2417 LINEAL FEET (0.46 MILES)
ILLINOIS ROUTE 62 = 2753 LINEAL FEET (0.52 MILES)
NET AND GROSS LENGTH OF PROJECT = 5170 LINEAL FEET (0.98 MILES)



STATE OF ILLINOIS
DEPARTMENT OF TRANSPORTATION

APPROVED DECEMBER 21 2016
[Signature]
KANE COUNTY, COUNTY ENGINEER

PASSED JANUARY 3 2016
[Signature]
DISTRICT ONE ENGINEER OF LOCAL ROADS & STREETS

RELEASING FOR BID
BASED ON LIMITED
REVIEW JANUARY 5 2017
[Signature]
REGIONAL ENGINEER

**PRINTED BY THE AUTHORITY
OF THE STATE OF ILLINOIS**

PROGRAM AND OFFICE ENGINEER: CHARLES F. RIDDLE, P.E., (847) 705-4406 SCHAUMBURG, IL

[Signature] 12/21/16
Expires 11/30/18

INDEX OF SHEETS

1	COVER SHEET
2	INDEX OF SHEETS, LIST OF HIGHWAY STANDARDS AND COMMITMENTS
3	GENERAL NOTES
4 TO 14	SUMMARY OF QUANTITIES
15 TO 19	TYPICAL SECTIONS
20	SUPERELEVATION DIAGRAMS
21 TO 23	SCHEDULE OF QUANTITIES
24 TO 26	ALIGNMENT AND TIES
27 TO 29	REMOVAL PLAN
30 TO 33	ROADWAY PLAN AND PROFILE
34	MULTI-USE PATH PROFILE
35 TO 43	MAINTENANCE OF TRAFFIC PLAN
44 TO 45	MAINTENANCE OF TRAFFIC DETAILS
46 TO 55	SOIL EROSION AND SEDIMENT CONTROL PLAN
56 TO 58	STORMWATER POLLUTION PREVENTION PLAN DETAILS
59 TO 63	DRAINAGE AND UTILITIES PLAN AND PROFILE
64 TO 65	BYPASS SEWER PLAN AND PROFILE
66 TO 67	UNDERDRAIN PLAN
68 TO 69	DRAINAGE DETAILS
70	DETENTION BASIN GRADING PLAN
71 TO 75	PLAT OF HIGHWAYS
76 TO 78	PAVEMENT JOINTING AND ELEVATION PLAN
79	INTERSECTION DETAILS
80 TO 81	ROADWAY DETAILS
82 TO 84	PAVEMENT MARKING AND SIGNING PLAN
85 TO 92	LANDSCAPING PLAN AND DETAILS
93 TO 104	TRAFFIC SIGNAL PLAN AND DETAILS
105 TO 111	62A RETAINING WALL PLANS AND BORINGS
112 TO 115	62B RETAINING WALL PLANS AND BORINGS
116 TO 128	DISTRICT ONE DESIGN DETAILS
129 TO 150	LONGMEADOW PARKWAY CROSS SECTIONS
151 TO 176	IL 62 CROSS SECTIONS
177	DETENTION BASIN CROSS SECTIONS

LIST OF HIGHWAY STANDARDS

000001-06	STANDARD SYMBOLS, ABBREVIATIONS AND PATTERNS
001001-02	AREAS OF REINFORCEMENT BARS
001006	DECIMAL OF AN INCH AND OF A FOOT
280001-07	TEMPORARY EROSION CONTROL SYSTEMS
406201-01	MAILBOX TURNOUT
420001-08	PAVEMENT JOINTS
420101-05	24' (7.2m) JOINTED PCC PAVEMENT
420601-06	24' (7.2 m) PCC PAVEMENT
483001-04	PCC SHOULDER
542001-05	CONCRETE END SECTIONS FOR PIPE CULVERTS, 15" THRU 84" DIA.
601001-05	PIPE UNDERDRAINS
602001-02	CATCH BASIN, TYPE A
602011-02	CATCH BASIN, TYPE C
602401-03	MANHOLE, TYPE A
602406-07	MANHOLE, TYPE A, 6' (1.8 m) DIAMETER
602601-04	PRECAST REINFORCED CONCRETE FLAT SLAB TOP
602701-02	MANHOLE STEPS
604001-04	FRAME AND LIDS, TYPE 1
604026-03	FRAME AND GRATE, TYPE 6
604036-03	GRATE, TYPE 8
604091-03	FRAME AND GRATE, TYPE 24
606001-06	CONCRETE CURB TYPE B AND COMBINATION CONCRETE CURB AND GUTTER
606301-04	PC CONCRETE ISLANDS AND MEDIANS
630001-10	STEEL PLATE BEAM GUARDRAIL
630201-06	PCC/BITUMINOUS STABILIZATION AT STEEL PLATE BEAM GUARDRAIL
630301-06	SHOULDER WIDENING FOR TYPE 1 (SPECIAL) GUARDRAIL TERMINALS
631031-14	TRAFFIC BARRIER TERMINAL, TYPE 6
635001-02	DELINEATORS
701001-02	OFF-ROAD OPERATIONS, 2L, 2W MORE THAN 15' (4.5 m) AWAY
701006-05	OFF-ROAD OPERATIONS, 2L, 2W, 15' (4.5 m) TO 24" (600 mm) FROM PAVEMENT EDGE
701011-04	OFF-ROAD MOVING OPERATIONS, 2L, 2W, DAY ONLY
701311-03	LANE CLOSURE, 2L, 2W, MOVING OPERATIONS - DAY ONLY
701326-04	LANE CLOSURE, 2L, 2W, PAVEMENT WIDENING, FOR SPEEDS • 45 MPH
701426-09	LANE CLOSURE, MULTILANE, INTERMITTENT OR MOVING OPERATION, FOR SPEEDS • 45 MPH
701501-06	URBAN LANE CLOSURE, 2L, 2W, UNDIVIDED
701502-07	URBAN LANE CLOSURE, 2L, 2W, WITH BIDIRECTIONAL LEFT TURN LANE
701602-07	URBAN LANE CLOSURE, MULTILANE, 2W WITH BIDIRECTIONAL LEFT TURN LANE
701701-10	URBAN LANE CLOSURE, MULTILANE INTERSECTION
701901-06	TRAFFIC CONTROL DEVICES
704001-08	TEMPORARY CONCRETE BARRIER
720001-01	SIGN PANEL MOUNTING DETAILS
720006-04	SIGN PANEL ERECTION DETAILS
720011-01	METAL POSTS FOR SIGNS, MARKERS AND DELINEATORS
720021-02	SIGN PANELS, EXTRUDED ALUMINUM TYPE
725001	OBJECT AND TERMINAL MARKERS
728001-01	TELESCOPING STEEL SIGN SUPPORT
729001-01	APPLICATIONS OF TYPES A AND B METAL POSTS (FOR SIGNS & MARKERS)
780001-05	TYPICAL PAVEMENT MARKINGS
782006	GUARDRAIL AND BARRIER WALL REFLECTOR MOUNTING DETAILS
805001-01	ELECTRICAL SERVICE INSTALLATION DETAILS
814001-03	HANDHOLES
814006-02	DOUBLE HANDHOLES
857001-01	STANDARD PHASE DESIGNATION DIAGRAMS AND PHASE SEQUENCES
862001-01	UNINTERRUPTIBLE POWER SUPPLY (UPS)
873001-02	TRAFFIC SIGNAL GROUNDING AND BONDING
877001-06	STEEL MAST ARM ASSEMBLY AND POLE 16' THROUGH 55'
877011-05	STEEL COMBINATION MAST ARM ASSEMBLY AND POLE 16' THROUGH 55'
878001-10	CONCRETE FOUNDATION DETAILS
880006-01	TRAFFIC SIGNAL MOUNTING DETAILS
886001-01	DETECTOR LOOP INSTALLATIONS
886006-01	TYPICAL LAYOUT FOR DETECTION LOOPS

DISTRICT ONE DETAILS

BD-03	OUTLET FOR CONCRETE CURB AND GUTTER
BD-05	CONCRETE MEDIAN TYPE SB (DOWELLED) AND CORRUGATED MEDIAN (MODIFIED)
BD-07	STORM SEWER CONNECTION TO EXISTING SEWER
BD-12	MANHOLE WITH RESTRICTOR PLATE
BD-34	DETAILS FOR DEPRESSED CURB & GUTTER AND SHOULDER TREATMENT AT TBT TY 1 SPL
BD-37	MANHOLE TYPE A 7 FT. DIAMETER
BD-48	PCC PAVEMENT ROUNDOUTS AT CURB & GUTTER
BD-51	BENCHING CONSTRUCTION DETAIL
BD-52	DETAIL OF PAVEMENT SEPERATION, JOINT FOR JOINTED PAVEMENTS AT INTERSECTIONS
TC-10	TRAFFIC CONTROL AND PROTECTION FOR SIDE ROADS, INTERSECTIONS AND DRIVEWAYS
TC-13	DISTRICT ONE TYPICAL PAVEMENT MARKINGS
TC-22	ARTERIAL ROAD INFORMATION SIGN
TC-26	DRIVEWAY ENTRANCE SIGNING
TS-05	DISTRICT ONE STANDARD TRAFFIC SIGNAL DESIGN DETAILS (8 SHEETS)

FILE NAME = P:\754-ent-gemove.dgn



USER NAME = r.jiang	DESIGNED - N/A	REVISED -
PLOT SCALE = 2.0000' / 1 in.	DRAWN - RGJ	REVISED -
PLOT DATE = 9/26/2017	CHECKED - RMG	REVISED -
	DATE - 9/5/2017	REVISED -

STATE OF ILLINOIS
DEPARTMENT OF TRANSPORTATION

INDEX OF SHEETS AND LIST OF HIGHWAY STANDARDS

SCALE: SHEET 1 OF 1 SHEETS STA. TO STA.

F.A.U. RTE.	SECTION	COUNTY	TOTAL SHEETS	SHEET NO.
2298	13-00215-30-PV	KANE	177	2
CONTRACT NO. 61D16			ILLINOIS FED. AID PROJECT	

GENERAL NOTES

SPECIFICATIONS, STANDARDS, AND SPECIAL PROVISIONS

1. ANY REFERENCE TO STANDARDS THROUGHOUT THE PLANS OR SPECIAL PROVISIONS SHALL BE INTERPRETED AS THE LATEST STANDARD OF THE ILLINOIS DEPARTMENT OF TRANSPORTATION UNLESS OTHERWISE NOTED.
2. THE CONTRACTOR SHALL AT ALL TIMES PROVIDE PROTECTION FOR TRAFFIC AS CALLED FOR IN THE APPLICATION OF TRAFFIC CONTROL DEVICES, THE STANDARD SPECIFICATIONS AND THE PLANS.
3. ALL WORK SHALL BE INCLUDED WITHIN THE PROPOSED ROW LIMITS OF THE PROJECT, AS SHOWN. NO EQUIPMENT, MATERIAL YARD OR FIELD OFFICE SHALL BE SETUP OR STORED ON TOWNSHIP OR PRIVATE PROPERTY WITHOUT WRITTEN PERMISSION OF THE ENGINEER.

UTILITIES

1. THE CONTRACTOR SHALL COOPERATE WITH THE COUNTY AND STATE IF ANY UTILITY IMPROVEMENTS ARE REQUIRED BY THE COUNTY OR STATE WITHIN THE DURATION OF THE CONTRACT.
2. THE CONTRACTOR SHALL BE RESPONSIBLE FOR CONTACTING THE OWNERS OF ALL UTILITIES PRIOR TO CONSTRUCTION TO DETERMINE THE LOCATION OF ALL UTILITY EQUIPMENT. THE CONTRACTOR SHALL COOPERATE WITH ALL UTILITY OWNERS AS PROVIDED FOR IN THE STANDARD SPECIFICATIONS IF UTILITY RELOCATION, ADJUSTMENT, OR PROTECTION IS NECESSARY.
3. THE LOCATION OF EXISTING DRAINAGE STRUCTURES, STORM SEWERS, WATER MAINS, SANITARY SEWERS, AND ANY OTHER PUBLIC OR PRIVATE UTILITIES AS SHOWN ON THE PLANS IS APPROXIMATE, AND THEIR EXACT LOCATION IS TO BE DETERMINED IN THE FIELD BY THE CONTRACTOR.
4. THE CONTRACTOR SHALL BE RESPONSIBLE FOR THE PROTECTION OF ALL UNDERGROUND AND SURFACE UTILITIES EVEN THOUGH THEY MAY NOT BE SHOWN ON THE PLANS. ANY UTILITY THAT IS DAMAGED DURING CONSTRUCTION SHALL BE REPAIRED OR REPLACED TO THE SATISFACTION OF THE OWNER.

SEWERS AND WATER MAINS

1. INLET FILTERS SHALL BE USED ON ALL EXISTING DRAINAGE STRUCTURES.
2. ANY LOOSE MATERIAL DEPOSITED IN THE FLOW LINE OF DRAINAGE STRUCTURES, WHICH OBSTRUCTS THE NATURAL FLOW OF WATER SHALL BE REMOVED AT THE CLOSE OF EACH WORKING DAY. PRIOR TO ACCEPTANCE OF THE IMPROVEMENT, ALL DRAINAGE STRUCTURES SHALL BE FREE OF DIRT AND DEBRIS. THIS WORK WILL NOT BE PAID FOR SEPARATELY BUT SHALL BE INCLUDED IN THE COST OF CATCH BASINS AND MANHOLES OF THE DIAMETER SPECIFIED.
3. WHEN EXISTING DRAINAGE FACILITIES ARE DISTURBED, THE CONTRACTOR SHALL PROVIDE AND MAINTAIN IN AN OPERATING CONDITION TEMPORARY OUTLETS AND CONNECTIONS FOR ALL DRAINS, SEWERS, AND CATCH BASINS. THE CONTRACTOR SHALL PROVIDE FACILITIES WHICH HAVE THE CAPACITY TO RECEIVE AND DISCHARGE THE STORM WATER FLOW RATES NORMALLY ACCEPTED AND RELEASED BY EXISTING DRAINAGE FACILITIES.
5. ALL FRAMES WITH CLOSED LIDS TO BE FURNISHED, AS PART OF THIS CONTRACT SHALL HAVE CAST INTO THE LID ONE OF THE FOLLOWING WORDS: FOR STORM SEWER STRUCTURES "STORM". FOR SANITARY SEWER STRUCTURES "SANITARY". FOR WATER SYSTEM STRUCTURES "WATER".
6. FRAME ELEVATIONS GIVEN ON THE PLANS ARE ONLY TO ASSIST THE CONTRACTOR IN DETERMINING THE APPROXIMATE OVERALL HEIGHT OF THE STRUCTURE. FRAMES ON ALL STRUCTURES WILL BE ADJUSTED TO THE FINAL ELEVATION AND CROSS SLOPE OF THE AREA IN WHICH THEY ARE LOCATED.
7. ANY FARM DRAIN, FIELD TILE SYSTEM, OR OTHER UNDERGROUND TILE FACILITY ENCOUNTERED IN THE WORK SHALL BE LOCATED AND STAKED AND REPORTED TO THE ENGINEER.
8. PIPE UNDERDRAINS TYPE 2 SHALL BE INSTALLED ACCORDING TO SECTION 601 OF THE SSRBC AND STANDARD 601001-05. TOP OF PIPE UNDERDRAINS SHALL BE PLACED 6" BELOW THE SUBGRADE OR UNDERCUT. THE COST OF MAKING PIPE UNDERDRAIN CONNECTIONS TO DRAINAGE STRUCTURES SHALL BE INCLUDED IN THE COST OF THE PIPE UNDERDRAINS.

PAVING

1. CONTRACTOR MUST BE OFF THE JOBSITE BY 9:00 PM ON PCC POUR DAYS WITH NO EXCEPTIONS. CUTTING JOINTS WILL NOT BE PERMITTED OVERNIGHT.

STAKING

1. ALL RADII FOR PROPOSED CURB AND GUTTER ARE TO THE EDGE OF PAVEMENT, UNLESS OTHERWISE NOTED. CURB AND GUTTER ELEVATIONS SHOWN AT POINTS OF CURVE, ETC., ARE EDGE OF PAVEMENT, UNLESS OTHERWISE NOTED.
2. STRUCTURE OFFSET LOCATIONS GIVEN ON THE DETAILED PLANS ARE TO THE FOLLOWING POINTS: A) FOR STRUCTURES FALLING IN THE CURB LINE TO EDGE OF PAVEMENT; B) FOR ALL OTHER STRUCTURES TO THE CENTER OF THE STRUCTURE.
3. ALL ELEVATIONS ARE ON U.S.G.S DATUM.

SIGNING AND PAVEMENT MARKING

1. PRIOR TO THE START OF CONSTRUCTION, THE CONTRACTOR, ENGINEER AND KANE CO. DOT MAINTENANCE PERSONNEL SHALL INVENTORY THE LOCATION, SIZE, TYPE AND CONDITION OF ALL EXISTING SIGNS. ANY SIGN DAMAGED DURING CONSTRUCTION SHALL BE REPLACED.
2. ALL SIGNS SHALL BE ERECTED IN STRICT CONFORMANCE WITH SECTION 720 OF THE STANDARD SPECIFICATIONS FOR ROAD AND BRIDGE CONSTRUCTION AND BY STATE PRE-QUALIFIED CONTRACTOR PERSONNEL, SUCH AS A SUB CONTRACTOR THAT SPECIALIZES IN TRAFFIC CONTROL AND SIGN PLACEMENT. TO INSURE THIS OPERATION IS PERFORMED CORRECTLY THERE WILL BE A WALKTHRU ON THE JOB WITH THE ENGINEER AND KANE CO. DOT MAINTENANCE PERSONNEL AS PART OF THE OVERALL PUNCH LIST.
3. ALL WORK INVOLVING SIGNS SHALL BE GOVERNED BY THE FOLLOWING REQUIREMENTS:
 - A. SIGNS SHALL NOT BE MOVED UNTIL PROGRESS OF WORK NECESSITATES IT.
 - B. ALL SIGNS SHALL BE INSTALLED OR RELOCATED IN PERMANENT LOCATIONS AS THE ROADWAY IS COMPLETED.
 - C. ALL REMOVED SIGNS WILL BE ASSESSED BY THE ENGINEER AS COORDINATED WITH THE COUNTY TO DETERMINE IF THEY ARE SALVAGEABLE. IF THE SIGNS ARE SALVAGEABLE, THE SIGNS SHALL BE RETURNED TO THE COUNTY TO A LOCATION TO BE DETERMINED.
 - D. LONGER POSTS MAY BE REQUIRED AT SOME TEMPORARY OR PERMANENT SIGN LOCATIONS TO MAINTAIN PROPER SIGN ELEVATIONS.
 - E. THE ENGINEER SHOULD NOTIFY THE IDOT TRAFFIC CONTROL SUPERVISOR AT (847)-705-4470 A MINIMUM OF 72 HOURS PRIOR TO PLACEMENT OF ANY TEMPORARY TRAFFIC CONTROL DEVICES ON IL ROUTE 62.
4. THE ENGINEER SHALL CONTACT DON CHIARUGI, AREA TRAFFIC FIELD ENGINEER, AT DON.CHIARUGI@ILLINOIS.GOV TWO WEEKS PRIOR TO INSTALLATION OF SIGNING AND PAVEMENT MARKINGS ON IL 62.

MISCELLANEOUS

1. BEFORE STARTING ANY EXCAVATIONS, THE CONTRACTOR SHALL CALL JULIE AT 1-800-892-0123 FOR FIELD LOCATIONS OF UTILITIES.
2. THE CONTRACTOR SHALL NOT BE ALLOWED TO SET UP A YARD OR FIELD OFFICE ON COUNTY PROPERTY WITHOUT WRITTEN PERMISSION FROM THE ENGINEER.
3. WHEN ARTIFICIAL LIGHTING IS USED IN NIGHT OPERATIONS THE CONTRACTOR SHALL EXERCISE THE UTMOST PRECAUTIONS IN PREVENTING ADVERSE VISIBILITY TO THE MOTORING PUBLIC AND ADJOINING AREAS. LIGHTING MUST BE TURNED OFF BY 9:00 PM.
4. THE CONTRACTOR SHALL MAINTAIN EXISTING SIDE STREET ACCESS, EXISTING DRIVEWAY ACCESS, AND PEDESTRIAN ACCESS TO ABUTTING PROPERTY AT ALL TIMES DURING CONSTRUCTION OF THE PROJECT UNLESS A DETOUR PLAN IS PROVIDED IN THE PLANS.
5. IT IS THE CONTRACTOR'S RESPONSIBILITY TO ASCERTAIN EXISTING FIELD CONDITIONS BEFORE BIDDING ON THIS CONTRACT.
6. WHERE NEW WORK MEETS EXISTING FEATURES TO REMAIN, FIELD CHECK ALL DIMENSIONS AND ELEVATIONS BEFORE PROCEEDING WITH CONSTRUCTION. NOTIFY ENGINEER IMMEDIATELY OF ANY DISCREPANCIES.
7. ALL DISTURBED AREAS WITHIN THE PROJECT THAT ARE NOT OTHERWISE SURFACED SHALL BE SEEDED. SEED LIMITS SHOWN ON THE PLANS ARE THE MAXIMUM PAY WIDTHS FOR PAYMENT PURPOSES.
8. FERTILIZER NUTRIENTS:
USE A FERTILIZER WITH AN ANALYSIS OF 1:1 RATIO AT THE FOLLOWING RATE PER ACRE:
NITROGEN FERTILIZER NUTRIENT 90 LBS.
POTASSIUM FERTILIZER NUTRIENT 90 LBS.

FERTILIZER IS NOT REQUIRED FOR SEEDING CLASS 3, 4A, AND 4B.
9. THE CONTRACTOR WILL BE REQUIRED TO TEMPORARILY RESET ALL EXISTING MAILBOXES WHICH INTERFERE WITH HIS CONSTRUCTION OPERATIONS, AND AFTER COMPLETION OF ROADWAY CONSTRUCTION, TO SET THEM IN THEIR PERMANENT LOCATIONS AS DIRECTED BY THE ENGINEER. THIS WORK SHALL BE IN CONFORMANCE WITH ARTICLE 107.20 OF THE STANDARD SPECIFICATIONS.
10. THE CONTRACTOR SHALL EXERCISE EXTREME CARE WHEN WORKING NEAR EXISTING TREES AND SHRUBS TO AVOID DAMAGING THOSE NOT SCHEDULED FOR REMOVAL AND SHALL REPLACE IN-KIND ANY DAMAGED PLANTS.

GEOTECHNICAL

1. THE SUBGRADE STABILITY SHALL BE VERIFIED BY PROOF ROLLING WITH A FULLY LOADED TANDEM-AXLE TRUCK.
2. AGGREGATE SUBGRADE IMPROVEMENT (CU YD) HAS BEEN PROVIDED FOR USE AT THE LOCATIONS INDICATED FOR SOILS THAT TEND TO BE UNSTABLE AND OR UNSUITABLE. THE ACTUAL NEED FOR REMOVAL AND REPLACEMENT WITH ASI WILL BE DETERMINED IN THE FIELD AT THE TIME OF CONSTRUCTION BY THE GEOTECHNICAL ENGINEER. ALL POTENTIALLY UNSTABLE SOILS SHOULD BE TESTED WITH A STATIC OR DYNAMIC CONE PENETROMETER AND TREATED IN ACCORDANCE WITH ARTICLE 301.04 (04/01/2016) OF THE SSRBC AND IDOT SUBGRADE STABILITY MANUAL. IF UNSTABLE AND/OR UNSUITABLE SOILS ARE NOT ENCOUNTERED, THEN THE QUANTITY SHALL BE DEDUCTED AND NO ADDITIONAL COMPENSATION WILL BE DUE TO THE CONTRACTOR.
3. IT IS ESTIMATED THAT THE EMBANKMENT AREAS ALONG LONGMEADOW PARKWAY WILL SETTLE MORE THAN 1 INCH. THE EMBANKMENT AREAS SHALL BE BUILT AS PART OF STAGE 1 TO MINIMIZE THE SETTLEMENT DURING THE PAVING OPERATION.

FILE NAME = 74754-shh-gennote.dgn



USER NAME = rjjiang	DESIGNED - N/A	REVISED -
PLOT SCALE = 2.0000' / in.	DRAWN - JIR	REVISED -
PLOT DATE = 9/29/2017	CHECKED - RMG	REVISED -
	DATE - 9/5/2017	REVISED -

**STATE OF ILLINOIS
DEPARTMENT OF TRANSPORTATION**

GENERAL NOTES

SCALE: SHEET 1 OF 1 SHEETS STA. TO STA.

F.A.U. RTE.	SECTION	COUNTY	TOTAL SHEETS	SHEET NO.
2298	13-00215-30-PV	KANE	177	3
			CONTRACT NO. 61D16	
ILLINOIS FED. AID PROJECT				

SPECIALTY ITEM	CODE NO.	ITEM	UNIT	TOTAL QUANTITY	PARTICIPATING 56.5% STATE/43.5% KANE COUNTY			
					ROADWAY 0001	SAFETY 0021	PEDESTRIAN TRAIL 0028	LANDSCAPING 0031
X	20100110	TREE REMOVAL (6 TO 15 UNITS DIAMETER)	UNIT	218				218
X	20100210	TREE REMOVAL (OVER 15 UNITS DIAMETER)	UNIT	195				195
X	20100500	TREE REMOVAL, ACRES	ACRE	9.75				9.75
	20101000	TEMPORARY FENCE	FOOT	9,584	9,584			
X	20101700	SUPPLEMENTAL WATERING	UNIT	642				642
	20200100	EARTH EXCAVATION	CU YD	66,758	66,758			
	20201200	REMOVAL AND DISPOSAL OF UNSUITABLE MATERIAL	CU YD	10,278	10,278			
	20800150	TRENCH BACKFILL	CU YD	2,459	2,459			
	21001000	GEOTECHNICAL FABRIC FOR GROUND STABILIZATION	SO YD	8,433	8,433			
	21101505	TOPSOIL EXCAVATION AND PLACEMENT	CU YD	9,910	9,910			
X	21101805	COMPOST FURNISH AND PLACE, 2"	SO YD	2,350				2,350
X	25000210	SEEDING, CLASS 2A	ACRE	8.00				8.00
X	25000400	NITROGEN FERTILIZER NUTRIENT	POUND	745				745
X	25000600	POTASSIUM FERTILIZER NUTRIENT	POUND	745				745
X	25100115	MULCH, METHOD 2	ACRE	16.50	16.50			
X	28000250	TEMPORARY EROSION CONTROL SEEDING	POUND	1,470	1,470			
	28000305	TEMPORARY DITCH CHECKS	FOOT	595	595			
	28000510	INLET FILTERS	EACH	115	115			
	28100207	STONE RIPRAP, CLASS A4	TON	755				755
	28100811	STONE DUMPED RIPRAP, CLASS A6	TON	42				42
	28200200	FILTER FABRIC	SO YD	1,406				1,406
	28500400	ARTICULATED BLOCK REVETMENT MAT	SO YD	250				250
	30300001	AGGREGATE SUBGRADE IMPROVEMENT	CU YD	10,278	10,278			
	30300112	AGGREGATE SUBGRADE IMPROVEMENT 12"	SO YD	46,959	46,959			
	31101200	SUBBASE GRANULAR MATERIAL, TYPE B 4"	SO YD	48			48	
	35101800	AGGREGATE BASE COURSE, TYPE B 6"	SO YD	3,064			3,064	

FILE NAME = 74754-rht-50001.dgn



USER NAME = r.jiang
 PLOT SCALE = 2.0000' / in.
 PLOT DATE = 9/1/2017

DESIGNED -
 DRAWN -
 CHECKED -
 DATE - 9/5/2017

REVISED -
 REVISED -
 REVISED -
 REVISED -

**STATE OF ILLINOIS
 DEPARTMENT OF TRANSPORTATION**

SUMMARY OF QUANTITIES

SCALE: SHEET 1 OF 11 SHEETS STA. TO STA.

F.A.U. RTE. 2298	SECTION 13-00215-30-PV	COUNTY KANE	TOTAL SHEETS 177	SHEET NO. 4
CONTRACT NO. 61D16				
ILLINOIS FED. AID PROJECT				

SPECIALTY ITEM	CODE NO.	ITEM	UNIT	TOTAL QUANTITY	PARTICIPATING 56.5% STATE/43.5% KANE COUNTY			
					ROADWAY 0001	SAFETY 0021	PEDESTRIAN TRAIL 0028	LANDSCAPING 0031
	35501308	HOT-MIX ASPHALT BASE COURSE, 6"	SO YD	594	594			
	40600275	BITUMINOUS MATERIALS (PRIME COAT)	POUND	6,895			6,895	
	40603080	HOT-MIX ASPHALT BINDER COURSE, IL-19.0, N50	TON	31	31			
	40603335	HOT-MIX ASPHALT SURFACE COURSE, MIX "D", N50	TON	524	97		427	
	40700100	BITUMINOUS MATERIALS (TACK COAT)	POUND	11,027	11,027			
	40701886	HOT-MIX ASPHALT PAVEMENT (FULL-DEPTH), 10 1/4"	SO YD	18,415	18,415			
	42000501	PORTLAND CEMENT CONCRETE PAVEMENT 10" (JOINTED)	SO YD	12,410	12,410			
	42001300	PROTECTIVE COAT	SO YD	17,277	17,277			
	42400200	PORTLAND CEMENT CONCRETE SIDEWALK 5 INCH	SO FT	430			430	
	42400800	DETECTABLE WARNINGS	SO FT	60			60	
	44000100	PAVEMENT REMOVAL	SO YD	15,945	15,945			
	44000200	DRIVEWAY PAVEMENT REMOVAL	SO YD	652	652			
	44000500	COMBINATION CURB AND GUTTER REMOVAL	FOOT	1,546	1,546			
	44004000	PAVED DITCH REMOVAL	FOOT	43	43			
	44004250	PAVED SHOULDER REMOVAL	SO YD	1,224	1,224			
	48101498	AGGREGATE SHOULDERS, TYPE B 4"	SO YD	37	37			
	48203038	HOT-MIX ASPHALT SHOULDERS, 10 1/4"	SO YD	5,584	5,584			
	50104400	CONCRETE HEADWALL REMOVAL	EACH	2	2			
	50105220	PIPE CULVERT REMOVAL	FOOT	221	221			
	50200100	STRUCTURE EXCAVATION	CU YD	268	268			
	50300225	CONCRETE STRUCTURES	CU YD	105	105			
	50300255	CONCRETE SUPERSTRUCTURE	CU YD	52	52			
	50300285	FORM LINER TEXTURED SURFACE	SO FT	1,437	1,437			
	50300300	PROTECTIVE COAT	SO YD	392	392			
	50500505	STUD SHEAR CONNECTORS	EACH	376	376			

FILE NAME = 74754-bht-50002.dgn



USER NAME = r.jiang
 PLOT SCALE = 2.0000' / 1" =
 PLOT DATE = 9/1/2017

DESIGNED -
 DRAWN -
 CHECKED -
 DATE - 9/5/2017

REVISED -
 REVISED -
 REVISED -
 REVISED -

STATE OF ILLINOIS
 DEPARTMENT OF TRANSPORTATION

SUMMARY OF QUANTITIES

SCALE: SHEET 2 OF 11 SHEETS STA. TO STA.

F.A.U. RTE.	SECTION	COUNTY	TOTAL SHEETS	SHEET NO.
2298	13-00215-30-PV	KANE	177	5
CONTRACT NO. 61D16				
ILLINOIS FED. AID PROJECT				

SPECIALTY ITEM	CODE NO.	ITEM	UNIT	TOTAL QUANTITY	PARTICIPATING 56.5% STATE/43.5% KANE COUNTY			
					ROADWAY 0001	SAFETY 0021	PEDESTRIAN TRAIL 0028	LANDSCAPING 0031
	50800205	REINFORCEMENT BARS, EPOXY COATED	POUND	14,020	14,020			
	52200020	TEMPORARY SOIL RETENTION SYSTEM	SO FT	5,230	5,230			
	52200100	FURNISHING SOLDIER PILES (HP SECTION)	FOOT	2,430	2,430			
	52200150	DRIVING SOLDIER PILES	FOOT	2,430	2,430			
	52200250	UNTREATED TIMBER LAGGING	SO FT	1,686	1,686			
	52200505	TEMPORARY MECHANICALLY STABILIZED EARTH RETAINING WALL	SO FT	2,718	2,718			
	54001001	BOX CULVERT END SECTIONS, CULVERT NO. 1	EACH	2	2			
	54213657	PRECAST REINFORCED CONCRETE FLARED END SECTIONS 12"	EACH	3	3			
	54213660	PRECAST REINFORCED CONCRETE FLARED END SECTIONS 15"	EACH	1	1			
	54213663	PRECAST REINFORCED CONCRETE FLARED END SECTIONS 18"	EACH	1	1			
	54213669	PRECAST REINFORCED CONCRETE FLARED END SECTIONS 24"	EACH	2	2			
	54213687	PRECAST REINFORCED CONCRETE FLARED END SECTIONS 42"	EACH	2	2			
	550A0070	STORM SEWERS, CLASS A, TYPE 1 15"	FOOT	12	12			
	550A0340	STORM SEWERS, CLASS A, TYPE 2 12"	FOOT	3,788	3,788			
	550A0360	STORM SEWERS, CLASS A, TYPE 2 15"	FOOT	491	491			
	550A0380	STORM SEWERS, CLASS A, TYPE 2 18"	FOOT	2,140	2,140			
	550A0410	STORM SEWERS, CLASS A, TYPE 2 24"	FOOT	671	671			
	550A0430	STORM SEWERS, CLASS A, TYPE 2 30"	FOOT	419	419			
	550A0450	STORM SEWERS, CLASS A, TYPE 2 36"	FOOT	1,731	1,731			
	550A0470	STORM SEWERS, CLASS A, TYPE 2 42"	FOOT	146	146			
	550A0480	STORM SEWERS, CLASS A, TYPE 2 48"	FOOT	319	319			
	550A0660	STORM SEWERS, CLASS A, TYPE 3 15"	FOOT	35	35			
	550A0680	STORM SEWERS, CLASS A, TYPE 3 18"	FOOT	214	214			
	550A0710	STORM SEWERS, CLASS A, TYPE 3 24"	FOOT	163	163			
	550A0750	STORM SEWERS, CLASS A, TYPE 3 36"	FOOT	105	105			

FILE NAME = 74754-ah-t-50003.dgn



USER NAME = r.jiang	DESIGNED -	REVISED -
PLOT SCALE = 2.0000' / 1in.	DRAWN -	REVISED -
PLOT DATE = 9/1/2017	CHECKED -	REVISED -
	DATE = 9/5/2017	REVISED -

**STATE OF ILLINOIS
DEPARTMENT OF TRANSPORTATION**

SUMMARY OF QUANTITIES			
SCALE:	SHEET 3	OF 11 SHEETS	STA. TO STA.

F.A.U. RTE.	SECTION	COUNTY	TOTAL SHEETS	SHEET NO.
2298	13-00215-30-PV	KANE	177	6
CONTRACT NO. 61D16				
ILLINOIS FED. AID PROJECT				

SPECIALTY ITEM	CODE NO.	ITEM	UNIT	TOTAL QUANTITY	PARTICIPATING 56.5% STATE/43.5% KANE COUNTY			
					ROADWAY 0001	SAFETY 0021	PEDESTRIAN TRAIL 0028	LANDSCAPING 0031
	550A0770	STORM SEWERS, CLASS A, TYPE 3 42"	FOOT	156	156			
	55100900	STORM SEWER REMOVAL 18"	FOOT	1,996	1,996			
	55101200	STORM SEWER REMOVAL 24"	FOOT	10	10			
	55200600	STORM SEWERS JACKED IN PLACE, 18"	FOOT	1,019	1,019			
	59100100	GEOCOMPOSITE WALL DRAIN	SQ YD	91	91			
	60108100	PIPE UNDERDRAINS 4" (SPECIAL)	FOOT	12	12			
	60108204	PIPE UNDERDRAINS, TYPE 2, 4"	FOOT	7,611	7,611			
	60200805	CATCH BASINS, TYPE A, 4'-DIAMETER, TYPE 8 GRATE	EACH	11	11			
	60201105	CATCH BASINS, TYPE A, 4'-DIAMETER, TYPE 11 FRAME AND GRATE	EACH	10	10			
	60201340	CATCH BASINS, TYPE A, 4'-DIAMETER, TYPE 24 FRAME AND GRATE	EACH	76	76			
	60204505	CATCH BASINS, TYPE A, 5'-DIAMETER, TYPE 8 GRATE	EACH	3	3			
	60205040	CATCH BASINS, TYPE A, 5'-DIAMETER, TYPE 24 FRAME AND GRATE	EACH	12	12			
	60206905	CATCH BASINS, TYPE C, TYPE 1 FRAME, OPEN LID	EACH	1	1			
	60207605	CATCH BASINS, TYPE C, TYPE 8 GRATE	EACH	4	4			
	60221100	MANHOLES, TYPE A, 5'-DIAMETER, TYPE 1 FRAME, CLOSED LID	EACH	37	37			
	60223800	MANHOLES, TYPE A, 6'-DIAMETER, TYPE 1 FRAME, CLOSED LID	EACH	2	2			
	60224446	MANHOLES, TYPE A, 7'-DIAMETER, TYPE 1 FRAME, CLOSED LID	EACH	1	1			
	60257900	MANHOLES TO BE RECONSTRUCTED	EACH	1	1			
	60500040	REMOVING MANHOLES	EACH	4	4			
	60500050	REMOVING CATCH BASINS	EACH	1	1			
	60600095	CLASS SI CONCRETE (OUTLET)	CU YD	5	5			
	60602800	CONCRETE GUTTER, TYPE B	FOOT	286	286			
	60603800	COMBINATION CONCRETE CURB AND GUTTER, TYPE B-6.12	FOOT	4,022	4,022			
	60605000	COMBINATION CONCRETE CURB AND GUTTER, TYPE B-6.24	FOOT	4,895	4,895			
	60608582	COMBINATION CONCRETE CURB AND GUTTER, TYPE M-4.24	FOOT	5,166	5,166			

FILE NAME = 74754-sh1-SC0084.dgn



USER NAME = r.jiang
 PLOT SCALE = 2.0000" / in.
 PLOT DATE = 9/1/2017

DESIGNED -
 DRAWN -
 CHECKED -
 DATE - 9/5/2017

REVISED -
 REVISED -
 REVISED -
 REVISED -

**STATE OF ILLINOIS
 DEPARTMENT OF TRANSPORTATION**

SUMMARY OF QUANTITIES

SCALE: SHEET 4 OF 11 SHEETS STA. TO STA.

F.A.U. RTE.	SECTION	COUNTY	TOTAL SHEETS	SHEET NO.
2298	13-00215-30-PV	KANE	177	7
CONTRACT NO. 61D16				
ILLINOIS FED. AID PROJECT				

SPECIALTY ITEM	CODE NO.	ITEM	UNIT	TOTAL QUANTITY	PARTICIPATING 56.5% STATE/43.5% KANE COUNTY			
					ROADWAY 0001	SAFETY 0021	PEDESTRIAN TRAIL 0028	LANDSCAPING 0031
	60618300	CONCRETE MEDIAN SURFACE, 4 INCH	SO FT	2,042	2,042			
	60619600	CONCRETE MEDIAN, TYPE SB-6.12	SO FT	2,212	2,212			
X	63000001	STEEL PLATE BEAM GUARDRAIL, TYPE A, 6 FOOT POSTS	FOOT	712.5		712.5		
X	63100085	TRAFFIC BARRIER TERMINAL, TYPE 6	EACH	2		2		
X	63100167	TRAFFIC BARRIER TERMINAL, TYPE 1 (SPECIAL) TANGENT	EACH	4		4		
X	63200310	GUARDRAIL REMOVAL	FOOT	1,682	1,682			
X	63500105	DELINEATORS	EACH	10		10		
X	66900200	NON-SPECIAL WASTE DISPOSAL	CU YD	10,333	10,333			
X	66900450	SPECIAL WASTE PLANS AND REPORTS	LSUM	1	1			
X	66900530	SOIL DISPOSAL ANALYSIS	EACH	4	4			
	67000400	ENGINEER'S FIELD OFFICE, TYPE A	CAL MO	18	18			
	67100100	MOBILIZATION	LSUM	1	1			
	70103815	TRAFFIC CONTROL SURVEILLANCE	CAL DA	287	287			
	70300240	TEMPORARY PAVEMENT MARKING - LINE 6"	FOOT	7,491	7,491			
	70300904	PAVEMENT MARKING TAPE, TYPE IV 4"	FOOT	47,799	47,799			
	70400100	TEMPORARY CONCRETE BARRIER	FOOT	3,487.5	3,487.5			
	70400200	RELOCATE TEMPORARY CONCRETE BARRIER	FOOT	4,000	4,000			
	70600280	IMPACT ATTENUATORS, TEMPORARY (SEVERE USE, NARROW), TEST LEVEL 3	EACH	10	10			
	70600370	IMPACT ATTENUATORS, RELOCATE (SEVERE USE, NARROW), TEST LEVEL 3	EACH	6	6			
	72000100	SIGN PANEL - TYPE 1	SO FT	141		141		
	72000200	SIGN PANEL - TYPE 2	SO FT	49		49		
	72400100	REMOVE SIGN PANEL ASSEMBLY - TYPE A	EACH	17	17			
X	72501000	TERMINAL MARKER - DIRECT APPLIED	EACH	4		4		
	72900100	METAL POST - TYPE A	FOOT	237		237		
	72900200	METAL POST - TYPE B	FOOT	144		144		

FILE NAME = 74754-shh-S0005.dgn



USER NAME = r.jiang
 PLOT SCALE = 2,0000' / in.
 PLOT DATE = 9/1/2017

DESIGNED -
 DRAWN -
 CHECKED -
 DATE - 9/5/2017

REVISED -
 REVISED -
 REVISED -
 REVISED -

STATE OF ILLINOIS
 DEPARTMENT OF TRANSPORTATION

SUMMARY OF QUANTITIES

SCALE: SHEET 5 OF 11 SHEETS STA. TO STA.

F.A.U. RTE. 2298	SECTION 13-00215-30-PV	COUNTY KANE	TOTAL SHEETS 177	SHEET NO. 8
CONTRACT NO. 61D16			ILLINOIS FED. AID PROJECT	

SPECIALTY ITEM	CODE NO.	ITEM	UNIT	TOTAL QUANTITY	PARTICIPATING 56.5% STATE/43.5% KANE COUNTY			
					ROADWAY 0001	SAFETY 0021	PEDESTRIAN TRAIL 0028	LANDSCAPING 0031
X	78003100	PREFORMED PLASTIC PAVEMENT MARKING, TYPE B - LETTERS AND SYMBOLS	SO FT	310		310		
X	78003110	PREFORMED PLASTIC PAVEMENT MARKING, TYPE B - LINE 4"	FOOT	20,410		20,410		
X	78003130	PREFORMED PLASTIC PAVEMENT MARKING, TYPE B - LINE 6"	FOOT	985		985		
X	78003140	PREFORMED PLASTIC PAVEMENT MARKING, TYPE B - LINE 8"	FOOT	350		350		
X	78003150	PREFORMED PLASTIC PAVEMENT MARKING, TYPE B - LINE 12"	FOOT	234		234		
X	78003180	PREFORMED PLASTIC PAVEMENT MARKING, TYPE B - LINE 24"	FOOT	178		178		
X	78009000	MODIFIED URETHANE PAVEMENT MARKING - LETTERS AND SYMBOLS	SO FT	182		182		
X	78009004	MODIFIED URETHANE PAVEMENT MARKING - LINE 4"	FOOT	5,552		5,552		
X	78009006	MODIFIED URETHANE PAVEMENT MARKING - LINE 6"	FOOT	737		737		
X	78009012	MODIFIED URETHANE PAVEMENT MARKING - LINE 12"	FOOT	258		258		
X	78200005	GUARDRAIL REFLECTORS TYPE A	EACH	40		40		
X	78200011	BARRIER WALL REFLECTORS, TYPE C	EACH	605	605			
X	81028200	UNDERGROUND CONDUIT, GALVANIZED STEEL, 2" DIA.	FOOT	661		661		
X	81028220	UNDERGROUND CONDUIT, GALVANIZED STEEL, 3" DIA.	FOOT	314		314		
X	81028240	UNDERGROUND CONDUIT, GALVANIZED STEEL, 4" DIA.	FOOT	278		278		
X	81400100	HANDHOLE	EACH	5		5		
X	81400200	HEAVY-DUTY HANDHOLE	EACH	1		1		
X	81400300	DOUBLE HANDHOLE	EACH	1		1		
X	87301225	ELECTRIC CABLE IN CONDUIT, SIGNAL NO. 14 3C	FOOT	433		433		
X	87301245	ELECTRIC CABLE IN CONDUIT, SIGNAL NO. 14 5C	FOOT	2,650		2,650		
X	87301255	ELECTRIC CABLE IN CONDUIT, SIGNAL NO. 14 7C	FOOT	1,095		1,095		
X	87301305	ELECTRIC CABLE IN CONDUIT, LEAD-IN, NO. 14 1 PAIR	FOOT	2,773		2,773		
X	87301805	ELECTRIC CABLE IN CONDUIT, SERVICE, NO. 6 2C	FOOT	145		145		
X	87301900	ELECTRIC CABLE IN CONDUIT, EQUIPMENT GROUNDING CONDUCTOR, NO. 6, 1C	FOOT	1,169		1,169		
X	87502500	TRAFFIC SIGNAL POST, GALVANIZED STEEL 16 FT.	EACH	1		1		

FILE NAME = 74754-sh1-SC006.dgn



USER NAME = r.jiang
 PLOT SCALE = 2.0000' / 1" =
 PLOT DATE = 9/1/2017

DESIGNED -
 DRAWN -
 CHECKED -
 DATE - 9/5/2017

REVISED -
 REVISED -
 REVISED -
 REVISED -

**STATE OF ILLINOIS
 DEPARTMENT OF TRANSPORTATION**

SUMMARY OF QUANTITIES

SCALE: SHEET 6 OF 11 SHEETS STA. TO STA.

F.A.U. RTE.	SECTION	COUNTY	TOTAL SHEETS	SHEET NO.
2298	13-00215-30-PV	KANE	177	9
ILLINOIS FED. AID PROJECT			CONTRACT NO. 61D16	

SPECIALTY ITEM	CODE NO.	ITEM	UNIT	TOTAL QUANTITY	PARTICIPATING 56.5% STATE/43.5% KANE COUNTY			
					ROADWAY 0001	SAFETY 0021	PEDESTRIAN TRAIL 0028	LANDSCAPING 0031
X	87700140	STEEL MAST ARM ASSEMBLY AND POLE, 20 FT.	EACH	1		1		
X	87700150	STEEL MAST ARM ASSEMBLY AND POLE, 22 FT.	EACH	1		1		
X	87700170	STEEL MAST ARM ASSEMBLY AND POLE, 26 FT.	EACH	1		1		
X	87700210	STEEL MAST ARM ASSEMBLY AND POLE, 34 FT.	EACH	1		1		
X	87700260	STEEL MAST ARM ASSEMBLY AND POLE, 44 FT.	EACH	1		1		
X	87800100	CONCRETE FOUNDATION, TYPE A	FOOT	8		8		
X	87800150	CONCRETE FOUNDATION, TYPE C	FOOT	4		4		
X	87800400	CONCRETE FOUNDATION, TYPE E 30-INCH DIAMETER	FOOT	30		30		
X	87800415	CONCRETE FOUNDATION, TYPE E 36-INCH DIAMETER	FOOT	24		24		
X	88030020	SIGNAL HEAD, LED, 1-FACE, 3 SECTION, MAST-ARM MOUNTED	EACH	7		7		
X	88030050	SIGNAL HEAD, LED, 1-FACE, 3 SECTION, BRACKET MOUNTED	EACH	3		3		
X	88030100	SIGNAL HEAD, LED, 1-FACE, 5-SECTION, BRACKET MOUNTED	EACH	1		1		
X	88030110	SIGNAL HEAD, LED, 1-FACE, 5-SECTION, MAST-ARM MOUNTED	EACH	4		4		
X	88200510	TRAFFIC SIGNAL BACKPLATE, RETROREFLECTIVE	EACH	15		15		
X	88500100	INDUCTIVE LOOP DETECTOR	EACH	17		17		
X	88600700	PREFORMED DETECTOR LOOP	FOOT	444		444		
**	X	88700200	LIGHT DETECTOR	EACH	3	3		
**	X	88700300	LIGHT DETECTOR AMPLIFIER	EACH	1	1		
X	A2002516	TREE, CARPINUS CAROLINIANA (AMERICAN HORNBEAM), 2" CALIPER, BALLED AND BURLAPPED	EACH	30				30
X	A2002716	TREE, CARYA OVATA (SHAGBARK HICKORY), 2" CALIPER, BALLED AND BURLAPPED	EACH	20				20
X	A2002816	TREE, CATALPA SPECIOSA (NORTHERN CATALPA), 2" CALIPER, BALLED AND BURLAPPED	EACH	12				12
X	A2002916	TREE, CELTIS OCCIDENTALIS (COMMON HACKBERRY), 2" CALIPER, BALLED AND BURLAPPED	EACH	31				31
X	A2005016	TREE, GYMNOCLADUS DIOICUS (KENTUCKY COFFEETREE), 2" CALIPER, BALLED AND BURLAPPED	EACH	9				9
X	A2005116	TREE, JUGLANS NIGRA (BLACK WALNUT), 2" CALIPER, BALLED AND BURLAPPED	EACH	8				8
X	A2005670	TREE, OSTRYA VIRGINIANA (EASTERN HOP HOPHORNBEAM), 8' HEIGHT, CLUMP FORM, BALLED AND BURLAPPED	EACH	27				27

** LOCAL FUNDING ONLY

FILE NAME = 74754-ahf-S0007.dgn



USER NAME = r.jiang
 PLOT SCALE = 2,0000' / in.
 PLOT DATE = 9/1/2017

DESIGNED -
 DRAWN -
 CHECKED -
 DATE - 9/5/2017

REVISED -
 REVISED -
 REVISED -
 REVISED -

STATE OF ILLINOIS
 DEPARTMENT OF TRANSPORTATION

SUMMARY OF QUANTITIES

SCALE: SHEET 7 OF 11 SHEETS STA. TO STA.

F.A.U. RTE.	SECTION	COUNTY	TOTAL SHEETS	SHEET NO.
2298	13-00215-30-PV	KANE	177	10
CONTRACT NO. 61D16				
ILLINOIS FED. AID PROJECT				

SPECIALTY ITEM	CODE NO.	ITEM	UNIT	TOTAL QUANTITY	PARTICIPATING 56.5% STATE/43.5% KANE COUNTY			
					ROADWAY 0001	SAFETY 0021	PEDESTRIAN TRAIL 0028	LANDSCAPING 0031
X	A2005956	TREE, PLATANUS ACERIFOLIA 'MORTON CIRCLE' (EXCLAMATION LONDON PLANETREE), 2" CALIPER, BALLED AND BURLAPPED	EACH	13				13
X	A2006216	TREE, POPULUS TREMULOIDES (OUAKING ASPEN), 2" CALIPER, BALLED AND BURLAPPED	EACH	14				14
X	A2006416	TREE, QUERCUS ALBA (WHITE OAK), 2" CALIPER, BALLED AND BURLAPPED	EACH	10				10
X	A2006516	TREE, QUERCUS BICOLOR (SWAMP WHITE OAK), 2" CALIPER, BALLED AND BURLAPPED	EACH	58				58
X	A2006616	TREE, QUERCUS IMBRICARIA (SHINGLE OAK), 2" CALIPER, BALLED AND BURLAPPED	EACH	38				38
X	A2006716	TREE, QUERCUS MACROCARPA (BUR OAK), 2" CALIPER, BALLED AND BURLAPPED	EACH	26				26
X	A2007116	TREE, QUERCUS RUBRA (RED OAK), 2" CALIPER, BALLED AND BURLAPPED	EACH	36				36
X	A2007316	TREE, SALIX ALBA TRISTIS (GOLDEN WEeping WILLOW), 2" CALIPER, BALLED AND BURLAPPED	EACH	6				6
X	A2007616	TREE, TAXODIUM DISTICHUM (COMMON BALD CYPRESS), 2" CALIPER, BALLED AND BURLAPPED	EACH	22				22
X	A2C010G5	TREE, ASIMINA TRILOBA (PAW PAW), CONTAINER GROWN, 5-GALLON	EACH	25				25
X	A2C025G5	TREE, CERCIS CANADENSIS (REDBUD), CONTAINER GROWN, 5-GALLON	EACH	24				24
X	B2001766	TREE, CRATAEGUS CRUSGALLI INERMIS CRUZAM (CRUSADER THORNLESS COCKSPUR HAWTHORN), 6' HEIGHT, SHRUB FORM, BALLED AND BURLAPPED	EACH	32				32
X	B2005068	TREE, MALUS SNOWDRIFT (SNOWDRIFE CRABAPPLE), 7' HEIGHT, CLUMP FORM, BALLED AND BURLAPPED	EACH	32				32
X	C20023G5	SHRUB, DIERVILLA LONICERA (BUSH HONEY SUCKLE), 5-GALLON	EACH	327				327
X	C2003236	SHRUB, HAMAMELIS VERNALIS (VERNAL WITCH HAZEL), 3' HEIGHT, BALLED AND BURLAPPED	EACH	57				57
X	C2003436	SHRUB, HYDRANGEA ARBORESCENS ANNABELLE (ANNABELLE SMOOTH HYDRANGEA), 3' HEIGHT, BALLED AND BURLAPPED	EACH	768				768
X	C2003624	SHRUB, HYPERICUM FRONDOSUM SUNBURST (SUN BURST ST. JOHNSWORT), 2' HEIGHT, BALLED AND BURLAPPED	EACH	50				50
X	C2010728	SHRUB, SYMPHORICARPOS X CHENAULTII HANCOCK, (HANCOCK CORALBERRY), CONTAINER GROWN, 5-GALLON	EACH	194				194
X	C2C003G3	SHRUB, AMOUPHA FRUITCOSA (INDIGO BUSH), CONTAINER GROWN, 3-GALLON	EACH	88				88
X	C2C00524	SHRUB, ARONIA MELANOCARPA (BLACK CHOKE BERRY), 2' HEIGHT, CONTAINER	EACH	130				130
X	C2C005G5	SHRUB, CORYLUS AMERICANA (AMERICAN FILBERT), CONTAINER GROWN, 5-GALLON	EACH	104				104
X	C2C01120	SHRUB, CEPHALANTHUS OCCIDENTALIS (BUTTON BUSH), 2' HEIGHT, CONTAINER	EACH	141				141
X	C2C016G3	SHRUB, CORNUS RACEMOSA (GRAY DOGWOOD), CONTAINER GROWN, 3-GALLON	EACH	69				69
X	C2C020G3	SHRUB, CORNUS STOLONIFERA (RED OSIER DOGWOOD), CONTAINER GROWN, 3-GALLON	EACH	19				19
X	C2C03930	SHRUB, ILEX VERTICILLATA JIM DANDY (JIM DANDY WINTERBERRY), 24" HEIGHT, CONTAINER	EACH	8				8
X	C2C03933	SHRUB, ILEX VERTICILLATA RED SPRITE (RED SPRITE WINTERBERRY), 24" HEIGHT, CONTAINER GROWN, 5-GALLON	EACH	60				60

FILE NAME = 74754-dwt-50008.dgn



USER NAME = rj.tang	DESIGNED -	REVISED -
PLOT SCALE = 2.0000' / in.	DRAWN -	REVISED -
PLOT DATE = 9/1/2017	CHECKED -	REVISED -
	DATE = 9/5/2017	REVISED -

**STATE OF ILLINOIS
DEPARTMENT OF TRANSPORTATION**

SUMMARY OF QUANTITIES			
SCALE:	SHEET	OF	TOTAL SHEETS
	8	11	11
	STA.		TO STA.

F.A.U. RTE.	SECTION	COUNTY	TOTAL SHEETS	SHEET NO.
2298	13-00215-30-PV	KANE	177	11
CONTRACT NO. 61D16				
ILLINOIS FED. AID PROJECT				

SPECIALTY ITEM	CODE NO.	ITEM	UNIT	TOTAL QUANTITY	PARTICIPATING 56.5% STATE/43.5% KANE COUNTY			
					ROADWAY 0001	SAFETY 0021	PEDESTRIAN TRAIL 0028	LANDSCAPING 0031
X	C2C043G5	SHRUB, LINDERA BENZOIN (SPICEBUSH), CONTAINER GROWN, 5-GALLON	EACH	57				57
X	C2C04738	SHRUB, PHYSCARPUS OPULIFOLIUS SUMMER (SUMMER WINE COMMON NINEBARK), 2-1/2' HEIGHT, CONTAINER	EACH	105				105
X	C2C053G3	SHRUB, PRUNUS AMERICANA (AMERICAN PLUM), CONTAINER GROWN, 3-GALLON	EACH	47				47
X	C2C06036	SHRUB, RHUS TYPHINA (STAGHORN SUMAC), 3' HEIGHT, CONTAINER	EACH	106				106
X	C2C06218	SHRUB, RIBES AMERICANUM (WILD BLACK CURRANT), 18" HEIGHT, CONTAINER	EACH	255				255
X	C2C09636	SHRUB, SAMBUCUS CANADENSIS (AMERICAN ELDER), 3' HEIGHT, CONTAINER	EACH	74				74
X	C2C100G5	SHRUB, VIBURNUM LENTAGO (NANNYBERRY), CONTAINER GROWN, 5-GALLON	EACH	95				95
X	C2C11736	SHRUB, VIBURNUM DENTATUM (ARROWWOOD VIBURNUM), 3' HEIGHT, CONTAINER	EACH	25				25
X	C2C12724	SHRUB, VIBURNUM PRUNIFOLIUM (BLACKHAW VIBURNUM), 2' HEIGHT, CONTAINER	EACH	55				55
X	D2000184	EVERGREEN, ABIES CONCOLOR (WHITE FIR), 7' HEIGHT, BALLED AND BURLAPPED	EACH	7				7
X	D2001572	EVERGREEN, JUNIPERUS VIRGINIANA (EASTERN RED CEDAR), 6' HEIGHT, BALLED AND BURLAPPED	EACH	47				47
X	D2002784	EVERGREEN, PINUS NIGRA (AUSTRIAN PINE), 7' HEIGHT, BALLED AND BURLAPPED	EACH	19				19
X	D2002984	EVERGREEN, PINUS STROBUS (EASTERN WHITE PINE), 7' HEIGHT, BALLED AND BURLAPPED	EACH	12				12
X	K0013030	PERENNIAL PLANTS, WETLAND TYPE, 2" DIAMETER BY 4" DEEP PLUG	UNIT	77				77
X	K0029614	WEED CONTROL, AQUATIC	GALLON	5				5
X	K0029624	WEED CONTROL, TEASEL	GALLON	5				5
X	K0029634	WEED CONTROL, PRE-EMERGENT GRANULAR HERBICIDE	POUND	95				95
	X0321865	ANTI-GRAFFITI PROTECTION SYSTEM	SO FT	1,437	1,437			
	X0324045	SEDIMENT CONTROL, STABILIZED CONSTRUCTION ENTRANCE REMOVAL	EACH	9	9			
**	X	X0324085	EMERGENCY VEHICLE PRIORITY SYSTEM LINE SENSOR CABLE, NO. 20 3/C	FOOT	435		435	
		X0324775	SEDIMENT CONTROL, STABILIZED CONSTRUCTION ENTRANCE MAINTENANCE	SO YD	2,510	2,510		
		X0324993	SEPARATION JOINT WITH SLEEPER SLAB	FOOT	57	57		
		X0325034	MANHOLES, TYPE A, 6'-DIAMETER, WITH 2 TYPE 1 FRAME, OPEN LIDS, RESTRICTOR PLATE	EACH	8	8		
		X0325318	LIGHTWEIGHT CELLULAR CONCRETE FILL	CU YD	24	24		
		X0327979	PAVEMENT MARKING REMOVAL - GRINDING	SO FT	3,739	3,739		

** LOCAL FUNDING ONLY

FILE NAME = 74754-shr-5009.dgn



USER NAME = r.jiang	DESIGNED -	REVISED -
PLOT SCALE = 2.0000' / 1" =	DRAWN -	REVISED -
PLOT DATE = 9/1/2017	CHECKED -	REVISED -
	DATE = 9/5/2017	REVISED -

STATE OF ILLINOIS
DEPARTMENT OF TRANSPORTATION

SUMMARY OF QUANTITIES

SCALE: SHEET 9 OF 11 SHEETS STA. TO STA.

F.A.U. RTE.	SECTION	COUNTY	TOTAL SHEETS	SHEET NO.
2298	13-00215-30-PV	KANE	177	12
CONTRACT NO. 61D16				
ILLINOIS FED. AID PROJECT				

SPECIALTY ITEM	CODE NO.	ITEM	UNIT	TOTAL QUANTITY	PARTICIPATING 56.5% STATE/43.5% KANE COUNTY			
					ROADWAY 0001	SAFETY 0021	PEDESTRIAN TRAIL 0028	LANDSCAPING 0031
	X0426200	DEWATERING	LSUM	1	1			
X	X1400107	FULL-ACTUATED CONTROLLER AND TYPE SUPER P CABINET	EACH	1		1		
X	X1400150	SERVICE INSTALLATION, GROUND MOUNTED, METERED	EACH	1		1		
X	X2501100	SEEDING CLASS, 3 (SPECIAL)	ACRE	2.50			2.50	
X	X2501750	SEEDING CLASS, 4 (SPECIAL)	ACRE	0.50			0.50	
X	X2502019	SEEDING CLASS, 4B (SPECIAL)	ACRE	0.25			0.25	
X	X2503110	MOWING (SPECIAL)	ACRE	483.75			483.75	
X	X2510635	HEAVY DUTY EROSION CONTROL BLANKET, SPECIAL	SQ YD	9,597	9,597			
X	X2511640	EROSION CONTROL BLANKET (MODIFIED)	SQ YD	61,234	61,234			
	X2800400	PERIMETER EROSION BARRIER, SPECIAL	FOOT	4,829	4,829			
	X4021000	TEMPORARY ACCESS (PRIVATE ENTRANCE)	EACH	8	8			
	X4023000	TEMPORARY ACCESS (ROAD)	EACH	2	2			
	X5030290	STAINING CONCRETE STRUCTURES	SQ FT	1,437	1,437			
	X5400504	PRECAST CONCRETE BOX CULVERTS 2' X 2' (SPECIAL)	FOOT	125	125			
	X5860110	GRANULAR BACKFILL FOR STRUCTURES	CU YD	20	20			
	X7010216	TRAFFIC CONTROL AND PROTECTION (SPECIAL)	LSUM	1	1			
	X7015005	CHANGEABLE MESSAGE SIGN	CAL DA	1,095	1,095			
	X7030005	TEMPORARY PAVEMENT MARKING REMOVAL	SQ FT	15,938	15,938			
	X7040125	PINNING TEMPORARY CONCRETE BARRIER	EACH	2,444	2,444			
X	X8620200	UNINTERRUPTABLE POWER SUPPLY, SPECIAL	EACH	1		1		
	XX006722	TEMPORARY AGGREGATE BERM-COARSE AGGREGATE	TON	13	13			
	XX006723	TEMPORARY AGGREGATE BERM-RIP RAP	TON	13	13			
	XX006821	CONCRETE TRUCK WASHOUT	LSUM	1	1			
	Z0013796	SEDIMENT CONTROL, STABILIZED CONSTRUCTION ENTRANCE	SQ YD	2,510	2,510			
	Z0013798	CONSTRUCTION LAYOUT	LSUM	1	1			
	Z0019600	DUST CONTROL WATERING	UNIT	225	225			

FILE NAME = 74754-sh1-S0010.dgn



USER NAME = r.jiang
 PLOT SCALE = 2.0000' / in.
 PLOT DATE = 9/1/2017

DESIGNED -
 DRAWN -
 CHECKED -
 DATE - 9/5/2017

REVISED -
 REVISED -
 REVISED -

**STATE OF ILLINOIS
 DEPARTMENT OF TRANSPORTATION**

SUMMARY OF QUANTITIES

SCALE: SHEET 10 OF 11 SHEETS STA. TO STA.

F.A.U. RTE.	SECTION	COUNTY	TOTAL SHEETS	SHEET NO.
2298	13-00215-30-PV	KANE	177	13
ILLINOIS FED. AID PROJECT			CONTRACT NO. 61D16	

SPECIALTY ITEM	CODE NO.	ITEM	UNIT	TOTAL QUANTITY	PARTICIPATING 56.5% STATE/43.5% KANE COUNTY			
					ROADWAY 0001	SAFETY 0021	PEDESTRIAN TRAIL 0028	LANDSCAPING 0031
	Z0022800	FENCE REMOVAL	FOOT	1,171	1,171			
	Z0023202	SEDIMENT CONTROL, DRAINAGE STRUCTURE INLET FILTER CLEANING	EACH	345	345			
	Z0030850	TEMPORARY INFORMATION SIGNING	SO FT	617	617			
	Z0046304	PIPE UNDERDRAINS FOR STRUCTURES 4"	FOOT	400	400			
	Z0062456	TEMPORARY PAVEMENT	SO YD	4,852	4,852			
▪	Z0076600	TRAINEES	HOUR	1,000	1,000			
▪	Z0076604	TRAINEES TRAINING PROGRAM GRADUATE	HOUR	1,000	1,000			

▪ CONSTRUCTION TYPE CODE 0042

FILE NAME = 74754-ah-5001.dgn



USER NAME = r.jiang	DESIGNED -	REVISED -
PLOT SCALE = 2.0000' / in.	DRAWN -	REVISED -
PLOT DATE = 9/1/2017	CHECKED -	REVISED -
	DATE - 9/5/2017	REVISED -

STATE OF ILLINOIS
DEPARTMENT OF TRANSPORTATION

SUMMARY OF QUANTITIES

SCALE: SHEET 11 OF 11 SHEETS STA. TO STA.

F.A.U. RTE.	SECTION	COUNTY	TOTAL SHEETS	SHEET NO.
2298	13-00215-30-PV	KANE	177	14
				CONTRACT NO. 61D16
ILLINOIS FED. AID PROJECT				

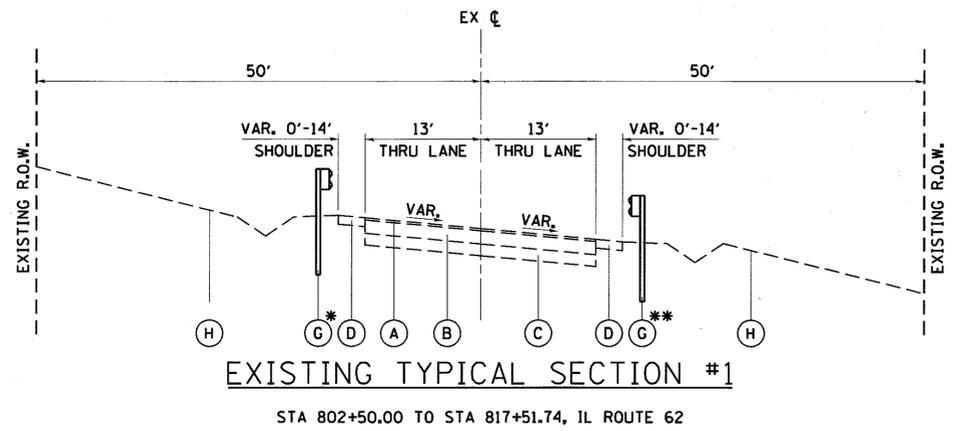
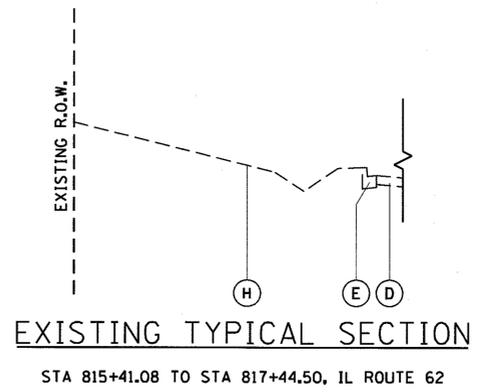

* STA 807+92.67 TO STA 812+26.83
** STA 807+84.04 TO STA 812+14.02

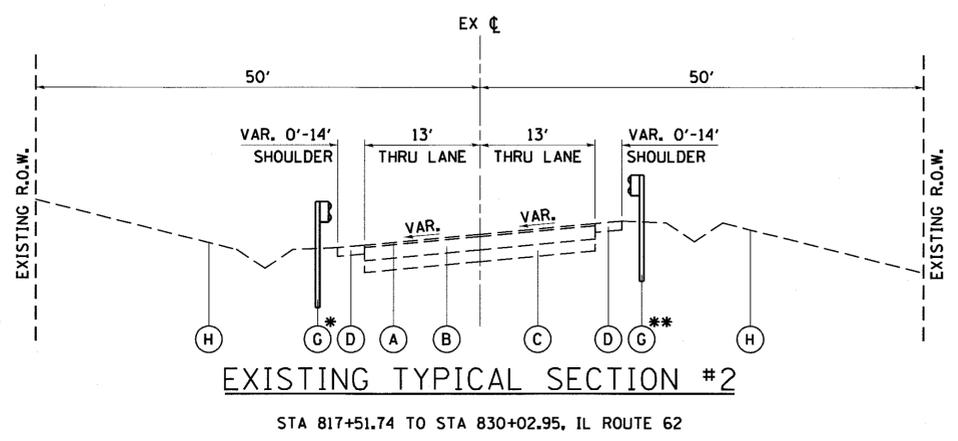
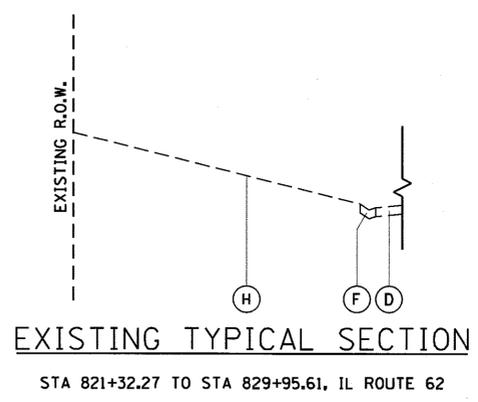

* STA 829+95.16 TO STA 830+02.95
** STA 828+74.65 TO STA 830+02.95

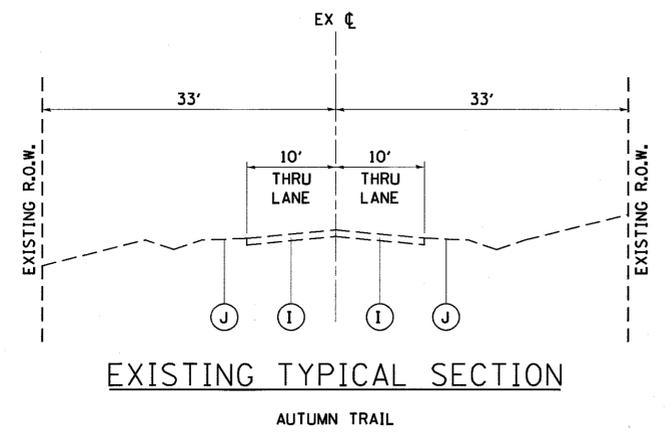
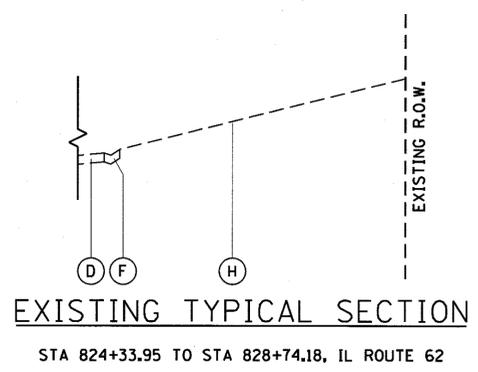

- LEGEND**
- EXISTING
- (A) HOT-MIX ASPHALT SURFACE COURSE, 1.5"
 - (B) HOT-MIX ASPHALT BINDER COURSE, 9"
 - (C) PORTLAND CEMENT CONCRETE BASE COURSE 9"
 - (D) HOT-MIX ASPHALT SHOULDERS, 8"
 - (E) COMB. CONC. CURB AND GUTTER, TYPE B-6.12
 - (F) CONCRETE GUTTER, TYPE B
 - (G) GUARDRAIL
 - (H) GRASS AREA
 - (I) HOT-MIX ASPHALT SURFACE COURSE, 1"
 - (J) EARTH SHOULDER
- NOTE: PAVEMENT THICKNESSES ARE TAKEN FROM PAVEMENT CORES AND SOIL BORINGS.

FILE NAME = 74754-shr-lyproca02.dgn

	USER NAME = r.jiang	DESIGNED - RGJ	REVISED -	STATE OF ILLINOIS DEPARTMENT OF TRANSPORTATION	EXISTING TYPICAL SECTIONS		F.A.U. RTE. 2298	SECTION 13-00215-30-PV	COUNTY KANE	TOTAL SHEETS 177	SHEET NO. 15
	PLOT SCALE = 20,0000' / in.	CHECKED - RMG	REVISED -				CONTRACT NO. 61D16				
	PLOT DATE = 9/1/2017	DATE - 9/5/2017	REVISED -				SCALE: SHEET 1 OF 5 SHEETS	STA. 802+50.00 TO STA. 830+02.95	ILLINOIS FED. AID PROJECT		

NOTES

1. THE REMOVAL OF UNSUITABLE MATERIAL SHALL BE PERFORMED AFTER THE TOPSOIL HAS BEEN STRIPPED AND SHALL BE REMOVED TO A WIDTH THAT ENCOMPASSES A 1:1 LINE FROM THE BOTTOM OF THE OUTSIDE BOTTOM OF SUBGRADE LINE. SEE CROSS SECTIONS FOR DETAILS.

LEGEND

- PROPOSED
- 1 PORTLAND CEMENT CONCRETE PAVEMENT 10" (JOINTED)
 - 2 HOT-MIX ASPHALT PAVEMENT (FULL-DEPTH), 10 1/4"
 - 3 AGGREGATE SUBGRADE IMPROVEMENT 12"
 - 4 HOT-MIX ASPHALT SHOULDERS, 10 1/4"
 - 5 TOPSOIL EXCAVATION AND PLACEMENT, 24" AND SEEDING
 - 6 COMB. CONC. CURB AND GUTTER, TYPE M-4.24
 - 7 COMB. CONC. CURB AND GUTTER, TYPE B-6.12
 - 8 COMB. CONC. CURB AND GUTTER, TYPE B-6.24
 - 9 TOPSOIL EXCAVATION AND PLACEMENT (6" DEPTH) AND SEEDING
 - 10 HOT-MIX ASPHALT SURFACE COURSE, MIX "D", N50 (3')
 - 11 AGGREGATE BASE COURSE, TYPE B 6"
 - 12 CONCRETE MEDIAN, TYPE SB-6.12
 - 13 GUARDRAIL
 - 14 LONGITUDINAL SAWED JOINT OR CONSTRUCTION JOINT. FOR LONGITUDINAL SAWED JOINT, POUR IN PLACE NO. 6 DEFORMED EPOXY TIE BARS 30" LONG AT 30" C-C. FOR LONGITUDINAL CONSTRUCTION JOINT, DRILL AND GROUT NO. 8 DEFORMED EPOXY TIE BARS 24" LONG AT 24" C-C. (SHALL BE INCLUDED IN THE COST OF PORTLAND CEMENT CONCRETE PAVEMENT 10" (JOINTED))
 - 15 LONGITUDINAL CONSTRUCTION JOINT. DRILL AND GROUT NO. 6 DEFORMED EPOXY TIE BARS 24" LONG AT 24" C-C. (SHALL BE INCLUDED IN THE COST OF THE APPLICABLE COMB. CONC. CURB AND GUTTER TYPE)
 - 16 RETAINING WALL
 - 17 CONCRETE MEDIAN SURFACE, 4"
 - 18 TOPSOIL EXCAVATION AND PLACEMENT (4" DEPTH) AND SEEDING
 - 19 PIPE UNDERDRAINS 4"
 - 20 REMOVAL OF UNSUITABLE MATERIALS
 - 21 AGGREGATE SUBGRADE IMPROVEMENT (CY)

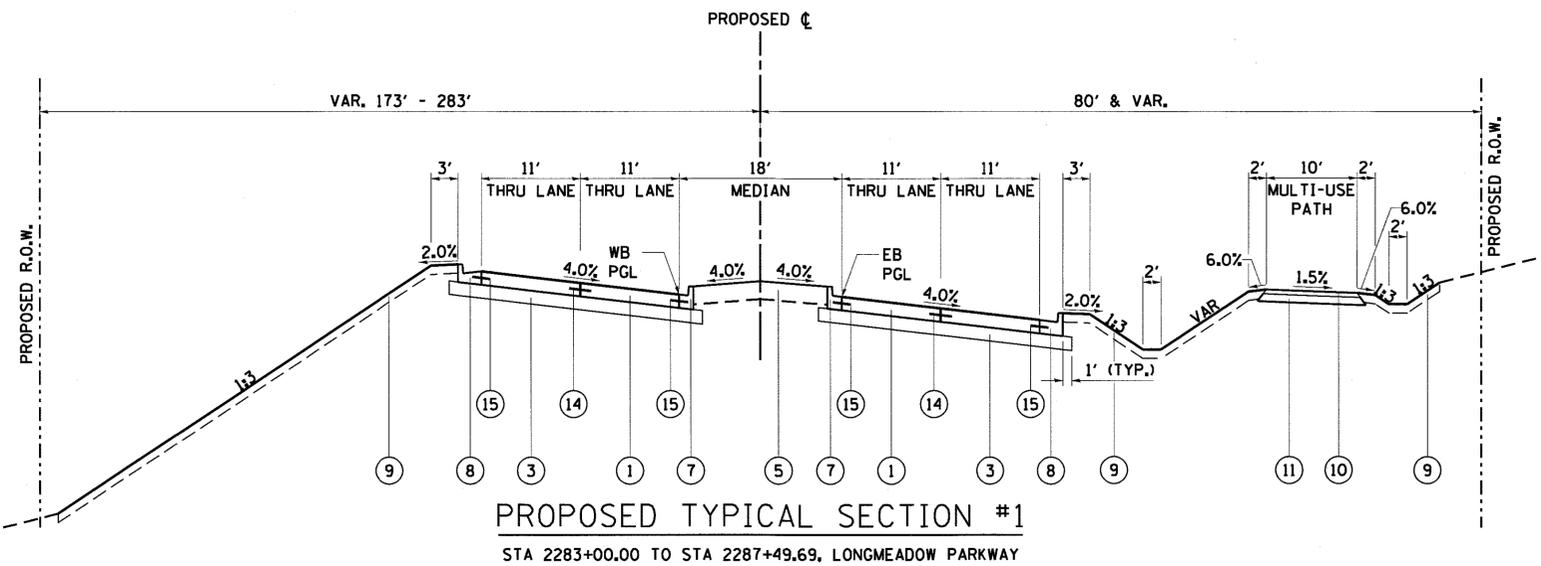

WB SUPERELEVATION TRANSITIONS

STA	SLOPE
2283+00.00 TO 2285+51.69	4.0% RIGHT
2285+51.69 TO 2287+49.69	TRANSITION TO N.C.

EB SUPERELEVATION TRANSITIONS

STA	SLOPE
2283+00.00 TO 2285+51.69	4.0% RIGHT
2285+51.69 TO 2286+17.69	TRANSITION TO N.C.
2286+17.69 TO 2287+49.69	N.C.

HOT-MIX ASPHALT MIXTURE REQUIREMENTS

ITEM	AIR VOIDS @ NDES	OMP
ILLINOIS ROUTE 62 (FULL DEPTH PAVEMENT), 10 1/4"		
POLYMERIZED HOT-MIX ASPHALT SURFACE COURSE, MIX "E", N70 (IL 9.5 mm) 2"	4% @ 70 GYR.	OCP
POLYMERIZED HOT-MIX ASPHALT BINDER COURSE, IL-19.0, N90, 2 1/4"	4% @ 90 GYR.	OCP
HOT-MIX ASPHALT BASE COURSE (HMA BINDER IL-19.0, N90), 6"	4% @ 90 GYR.	OCP
HOT-MIX ASPHALT SHOULDERS, 10 1/4"		
POLYMERIZED HOT-MIX ASPHALT SURFACE COURSE, MIX "E", N70 (IL 9.5 mm) 2"	4% @ 70 GYR.	OCP
HOT-MIX ASPHALT SHOULDER (HMA BINDER IL-19.0), 8 1/4"	4% @ 70 GYR.	OCP
AUTUMN TRAIL		
HOT-MIX ASPHALT SURFACE COURSE, MIX "D", N50 (IL 9.5 mm) 2"	4% @ 50 GYR.	OC/OA
HOT-MIX ASPHALT BINDER COURSE, IL-19.0, N50, 2 1/4"	4% @ 50 GYR.	OC/OA
PRIVATE ENTRANCES		
HOT-MIX ASPHALT SURFACE COURSE, MIX "D", N50 (IL 9.5 mm) 2"	4% @ 50 GYR.	OC/OA
HOT-MIX ASPHALT BASE COURSE, (HMA BINDER IL-19 mm) 6"	4% @ 50 GYR.	OC/OA
MULTI-USE PATH		
HOT-MIX ASPHALT SURFACE COURSE, MIX "D", N50 (IL 9.5 mm) 3"	4% @ 50 GYR.	OC/OA
TEMPORARY PAVEMENT		
HOT-MIX ASPHALT SURFACE COURSE, MIX "D", N70 (IL 9.5 mm) 2"	4% @ 70 GYR.	OC/OA
HOT-MIX ASPHALT BINDER COURSE, IL-19mm, N70, 8"	4% @ 70 GYR.	OC/OA

OMP DESIGNATION: QUALITY CONTROL/QUALITY ASSURANCE (OC/OA); QUALITY CONTROL FOR PERFORMANCE (OCP). THE UNIT WEIGHT USED TO CALCULATE ALL HMA SURFACE QUANTITIES IS 112 LB/SY-IN.

THE "AC TYPE" FOR POLYMERIZED HMA MIXES SHALL BE "SBS/SBR PG 76-22" AND FOR NON-POLYMERIZED HMA THE "AC TYPE" SHALL BE "PG 64-22" UNLESS MODIFIED BY DISTRICT ONE SPECIAL PROVISIONS.

QUALITY MANAGEMENT PROGRAM (OMP) IDENTIFIES THE PARTICULAR QUALITY CONTROL SPECIFICATION THAT APPLIES TO THE HMA MIXTURE.

PCC TEMPORARY PAVEMENT SHALL CONSIST OF CLASS PV CONCRETE MEETING THE REQUIREMENTS OF ART. 1020 OF THE STANDARD SPECIFICATIONS; THICKNESS SHALL BE 8". TEMPORARY PCC PAVEMENT DOES NOT REQUIRE DOWEL BARS.

FOR HMA FULL DEPTH "AC TYPE" SEE SPECIAL PROVISIONS.

FOR USE OF RECYCLED MATERIALS SEE SPECIAL PROVISIONS.

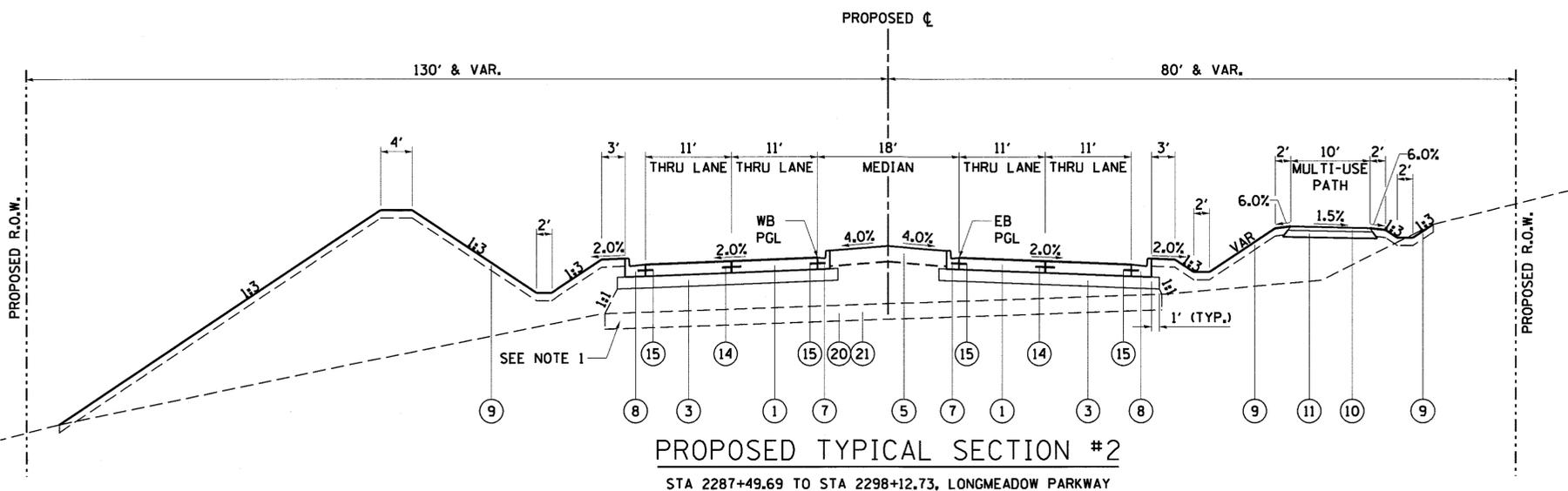

UNDERCUT TABLE

FROM STA	TO STA	DEPTH
2292+50	2295+50	12 INCHES

FILE NAME = 74754-ent-typical102.dgn



USER NAME = rjiang	DESIGNED - MAP	REVISED -
PLOT SCALE = 20.0000' / 1"	DRAWN - RGJ	REVISED -
PLOT DATE = 9/28/2017	CHECKED - RMG	REVISED -
	DATE - 9/5/2017	REVISED -

**STATE OF ILLINOIS
DEPARTMENT OF TRANSPORTATION**

**PROPOSED TYPICAL SECTIONS
LONGMEADOW PARKWAY**

SCALE: SHEET 2 OF 5 SHEETS STA. 2283+00.00 TO STA. 2298+12.73

F.A.U. RTE.	SECTION	COUNTY	TOTAL SHEETS	SHEET NO.
2298	13-00215-30-PV	KANE	177	16

CONTRACT NO. 61D16
ILLINOIS FED. AID PROJECT

LEGEND

PROPOSED

- ① PORTLAND CEMENT CONCRETE PAVEMENT 10" (JOINTED)
- ② HOT-MIX ASPHALT PAVEMENT (FULL-DEPTH), 10 1/4"
- ③ AGGREGATE SUBGRADE IMPROVEMENT 12"
- ④ HOT-MIX ASPHALT SHOULDERS, 10 1/4"
- ⑤ TOPSOIL EXCAVATION AND PLACEMENT, 24" AND SEEDING
- ⑥ COMB. CONC. CURB AND GUTTER, TYPE M-4.24
- ⑦ COMB. CONC. CURB AND GUTTER, TYPE B-6.12
- ⑧ COMB. CONC. CURB AND GUTTER, TYPE B-6.24
- ⑨ TOPSOIL EXCAVATION AND PLACEMENT (6" DEPTH) AND SEEDING
- ⑩ HOT-MIX ASPHALT SURFACE COURSE, MIX "D", N50 (3")
- ⑪ AGGREGATE BASE COURSE, TYPE B 6"
- ⑫ CONCRETE MEDIAN, TYPE SB-6.12
- ⑬ GUARDRAIL
- ⑭ LONGITUDINAL SAWED JOINT OR CONSTRUCTION JOINT. FOR LONGITUDINAL SAWED JOINT, POUR IN PLACE NO. 6 DEFORMED EPOXY TIE BARS 30" LONG AT 30" C-C. FOR LONGITUDINAL CONSTRUCTION JOINT, DRILL AND GROUT NO. 8 DEFORMED EPOXY TIE BARS 24" LONG AT 24" C-C. (SHALL BE INCLUDED IN THE COST OF PORTLAND CEMENT CONCRETE PAVEMENT 10" (JOINTED))
- ⑮ LONGITUDINAL CONSTRUCTION JOINT. DRILL AND GROUT NO. 6 DEFORMED EPOXY TIE BARS 24" LONG AT 24" C-C. (SHALL BE INCLUDED IN THE COST OF THE APPLICABLE COMB. CONC. CURB AND GUTTER TYPE)
- ⑯ RETAINING WALL
- ⑰ CONCRETE MEDIAN SURFACE, 4"
- ⑱ TOPSOIL EXCAVATION AND PLACEMENT (4" DEPTH) AND SEEDING
- ⑲ PIPE UNDERDRAINS 4"
- ⑳ REMOVAL OF UNSUITABLE MATERIALS
- ㉑ AGGREGATE SUBGRADE IMPROVEMENT (CY)

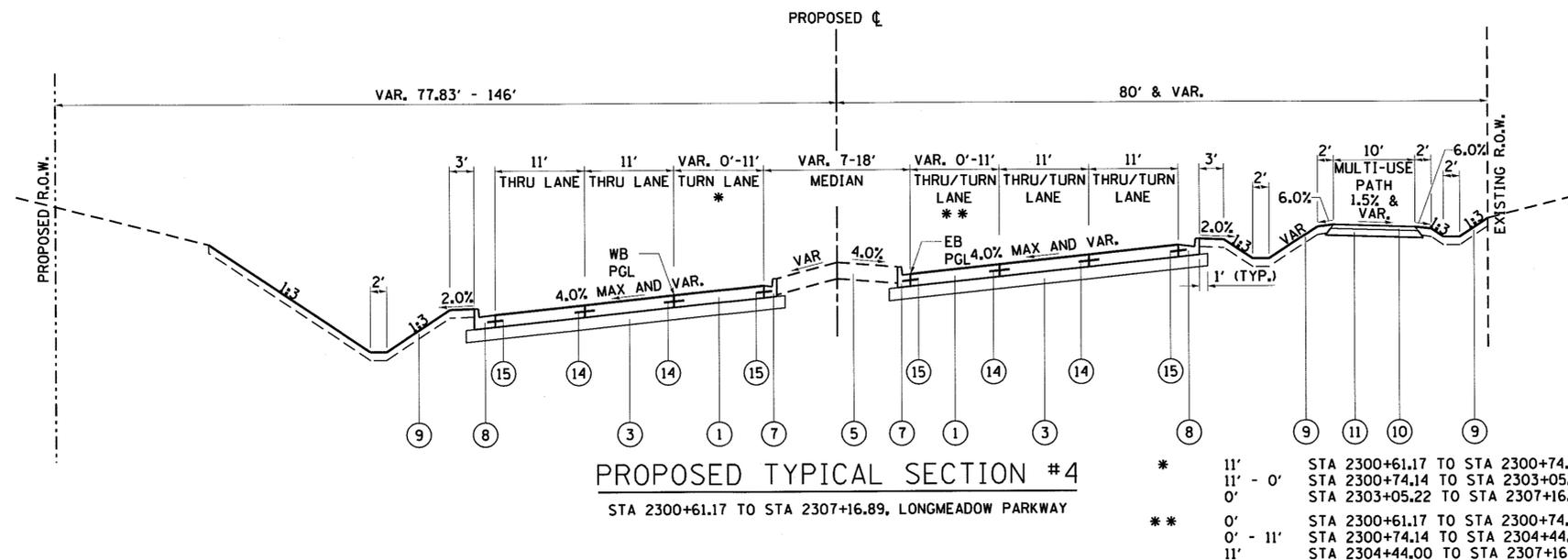
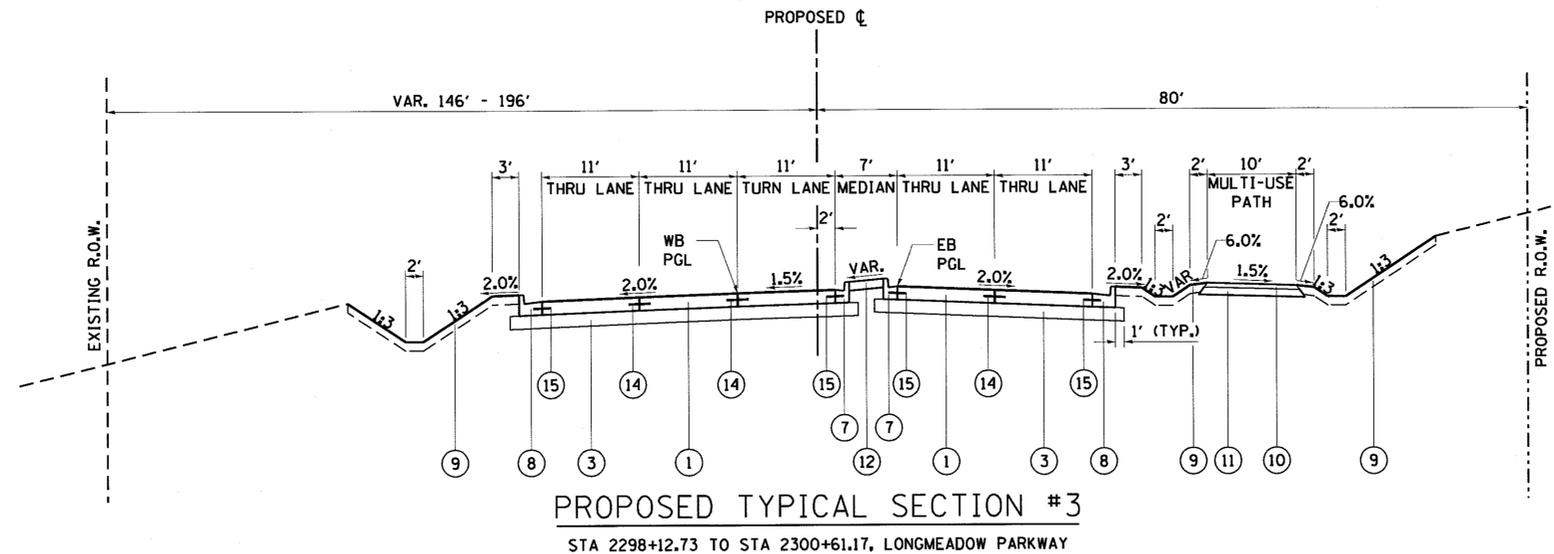

* 11' - STA 2300+61.17 TO STA 2300+74.14
 11' - 0' STA 2300+74.14 TO STA 2303+05.22
 0' STA 2303+05.22 TO STA 2307+16.89
 ** 0' - STA 2300+61.17 TO STA 2300+74.14
 0' - 11' STA 2300+74.14 TO STA 2304+44.00
 11' STA 2304+44.00 TO STA 2307+16.89

WB SUPERELEVATION TRANSITIONS

STA	SLOPE
2299+98.48 TO 2300+41.13	N.C.
2300+41.13 TO 2301+07.13	TRANSITION
2301+07.13 TO 2304+59.31	4.0% LEFT
2304+59.31 TO 2307+16.89	TRANSITION

EB SUPERELEVATION TRANSITIONS

STA	SLOPE
2299+98.48 TO 2301+96.48	TRANSITION
2301+96.48 TO 2304+59.31	4.0% LEFT
2304+59.31 TO 2307+16.89	TRANSITION

FILE NAME = 74754-ahc-typical03.dgn

* VARIES 0' TO 12' BETWEEN
STA 802+50.00 AND STA 807+84.45

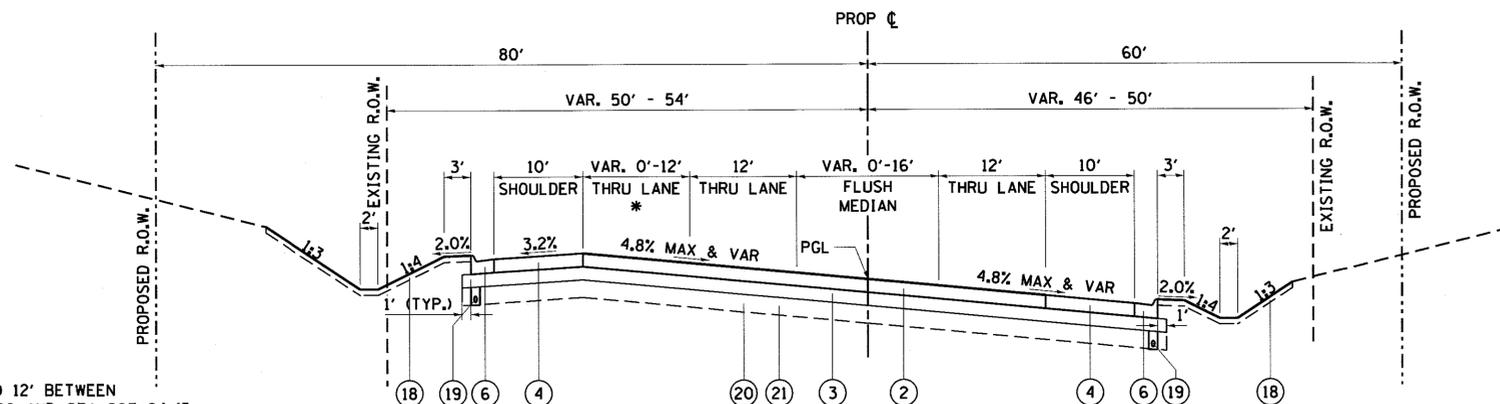

SB SUPERELEVATION TRANSITIONS

PROPOSED TYPICAL SECTION #1

NB SUPERELEVATION TRANSITIONS

STA	SLOPE
802+50.00 TO 803+38.00	TRANSITION FROM EXISTING AT CONST. LIMIT
803+38.00 TO 807+84.45	4.8%

STA 802+50.00 TO STA 807+84.45, IL ROUTE 62

STA	SLOPE
802+50.00 TO 802+56.00	TRANSITION FROM EXISTING AT CONST. LIMIT
802+56.00 TO 807+84.45	4.8%

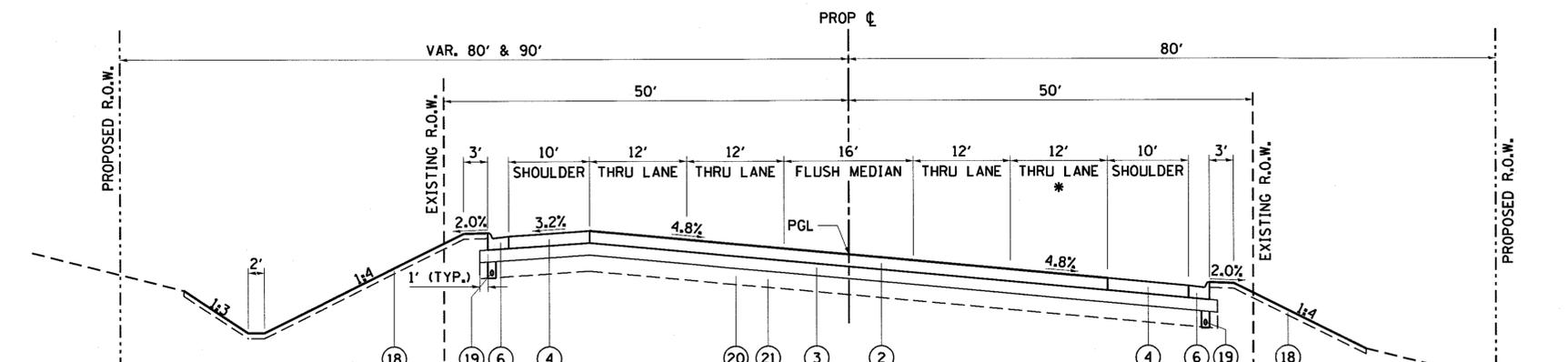

PROPOSED TYPICAL SECTION #2

STA 807+84.45 TO STA 811+52.23, IL ROUTE 62

* VARIES 0' TO 12' BETWEEN
STA 807+84.45 AND STA 810+85.87

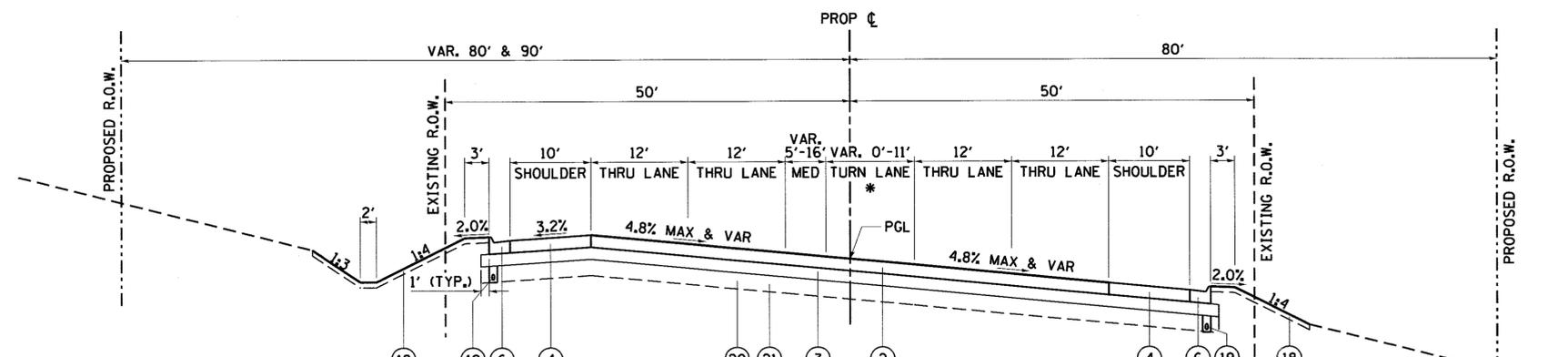

PROPOSED TYPICAL SECTION #3 NB/SB SUPERELEVATION TRANSITIONS

STA 811+52.23 TO STA 817+30.98, IL ROUTE 62

STA	SLOPE
811+52.23 TO 815+21.62	4.8% RIGHT
815+21.62 TO 817+30.98	TRANSITION TO 0.2% RIGHT

* VARIES 0' TO 11' BETWEEN STA 811+52.23 AND STA 814+17.23
CONSTANT 11' WIDTH BETWEEN STA 814+17.23 AND STA 817+30.98

LEGEND

PROPOSED

- ① PORTLAND CEMENT CONCRETE PAVEMENT 10" (JOINTED)
- ② HOT-MIX ASPHALT PAVEMENT (FULL-DEPTH), 10 1/4"
- ③ AGGREGATE SUBGRADE IMPROVEMENT 12"
- ④ HOT-MIX ASPHALT SHOULDERS, 10 1/4"
- ⑤ TOPSOIL EXCAVATION AND PLACEMENT, 24" AND SEEDING
- ⑥ COMB. CONC. CURB AND GUTTER, TYPE M-4.24
- ⑦ COMB. CONC. CURB AND GUTTER, TYPE B-6.12
- ⑧ COMB. CONC. CURB AND GUTTER, TYPE B-6.24
- ⑨ TOPSOIL EXCAVATION AND PLACEMENT (6" DEPTH) AND SEEDING
- ⑩ HOT-MIX ASPHALT SURFACE COURSE, MIX "D", N50 (3")
- ⑪ AGGREGATE BASE COURSE, TYPE B 6"
- ⑫ CONCRETE MEDIAN, TYPE SB-6.12
- ⑬ GUARDRAIL
- ⑭ LONGITUDINAL SAWED JOINT OR CONSTRUCTION JOINT. FOR LONGITUDINAL SAWED JOINT, POUR IN PLACE NO. 6 DEFORMED EPOXY TIE BARS 30" LONG AT 30" C-C. FOR LONGITUDINAL CONSTRUCTION JOINT, DRILL AND GROUT NO. 8 DEFORMED EPOXY TIE BARS 24" LONG AT 24" C-C. (SHALL BE INCLUDED IN THE COST OF PORTLAND CEMENT CONCRETE PAVEMENT 10" (JOINTED))
- ⑮ LONGITUDINAL CONSTRUCTION JOINT. DRILL AND GROUT NO. 6 DEFORMED EPOXY TIE BARS 24" LONG AT 24" C-C. (SHALL BE INCLUDED IN THE COST OF THE APPLICABLE COMB. CONC. CURB AND GUTTER TYPE)
- ⑯ RETAINING WALL
- ⑰ CONCRETE MEDIAN SURFACE, 4"
- ⑱ TOPSOIL EXCAVATION AND PLACEMENT (4" DEPTH) AND SEEDING
- ⑲ PIPE UNDERDRAINS 4"
- ⑳ REMOVAL OF UNSUITABLE MATERIALS
- ㉑ AGGREGATE SUBGRADE IMPROVEMENT (CY)

UNDERCUT TABLE

FROM STA	TO STA	DEPTH
807+50	817+00	12 INCHES

FILE NAME = 74754-111-111-111.dwg



USER NAME = r.jiang	DESIGNED - MAP	REVISED -
PLOT SCALE = 20,0000' / 1"	DRAWN - RGJ	REVISED -
PLOT DATE = 9/1/2017	CHECKED - RMG	REVISED -
	DATE - 9/5/2017	REVISED -

**STATE OF ILLINOIS
DEPARTMENT OF TRANSPORTATION**

PROPOSED TYPICAL SECTIONS ILLINOIS ROUTE 62	
SCALE:	SHEET 4 OF 5 SHEETS STA. 802+50.00 TO STA. 817+30.98

F.A.U. RTE.	SECTION	COUNTY	TOTAL SHEETS	SHEET NO.
2298	13-00215-30-PV	KANE	177	18
CONTRACT NO. 61D16				
ILLINOIS FED. AID PROJECT				

LEGEND

PROPOSED

- ① PORTLAND CEMENT CONCRETE PAVEMENT 10" (JOINTED)
- ② HOT-MIX ASPHALT PAVEMENT (FULL-DEPTH), 10 1/4"
- ③ AGGREGATE SUBGRADE IMPROVEMENT 12"
- ④ HOT-MIX ASPHALT SHOULDERS, 10 1/4"
- ⑤ TOPSOIL EXCAVATION AND PLACEMENT, 24" AND SEEDING
- ⑥ COMB. CONC. CURB AND GUTTER, TYPE M-4.24
- ⑦ COMB. CONC. CURB AND GUTTER, TYPE B-6.12
- ⑧ COMB. CONC. CURB AND GUTTER, TYPE B-6.24
- ⑨ TOPSOIL EXCAVATION AND PLACEMENT (6" DEPTH) AND SEEDING
- ⑩ HOT-MIX ASPHALT SURFACE COURSE, MIX "D", N50 (3")
- ⑪ AGGREGATE BASE COURSE, TYPE B 6"
- ⑫ CONCRETE MEDIAN, TYPE SB-6.12
- ⑬ GUARDRAIL
- ⑭ LONGITUDINAL SAWED JOINT OR CONSTRUCTION JOINT. FOR LONGITUDINAL SAWED JOINT, POUR IN PLACE NO. 6 DEFORMED EPOXY TIE BARS 30" LONG AT 30" C-C. FOR LONGITUDINAL CONSTRUCTION JOINT, DRILL AND GROUT NO. 8 DEFORMED EPOXY TIE BARS 24" LONG AT 24" C-C. (SHALL BE INCLUDED IN THE COST OF PORTLAND CEMENT CONCRETE PAVEMENT 10" (JOINTED))
- ⑮ LONGITUDINAL CONSTRUCTION JOINT. DRILL AND GROUT NO. 6 DEFORMED EPOXY TIE BARS 24" LONG AT 24" C-C. (SHALL BE INCLUDED IN THE COST OF THE APPLICABLE COMB. CONC. CURB AND GUTTER TYPE)
- ⑯ RETAINING WALL
- ⑰ CONCRETE MEDIAN SURFACE, 4"
- ⑱ TOPSOIL EXCAVATION AND PLACEMENT (4" DEPTH) AND SEEDING
- ⑲ PIPE UNDERDRAINS 4"
- ⑳ REMOVAL OF UNSUITABLE MATERIALS
- ㉑ AGGREGATE SUBGRADE IMPROVEMENT (CY)

UNDERCUT TABLE

FROM STA	TO STA	DEPTH
823+50	830+00	12 INCHES

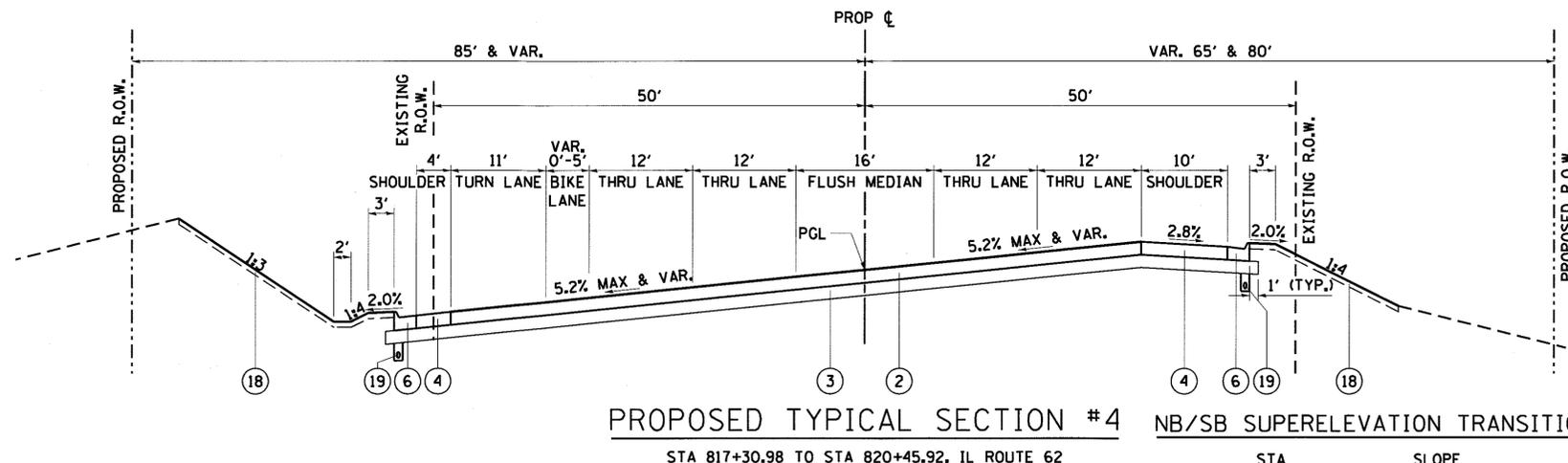
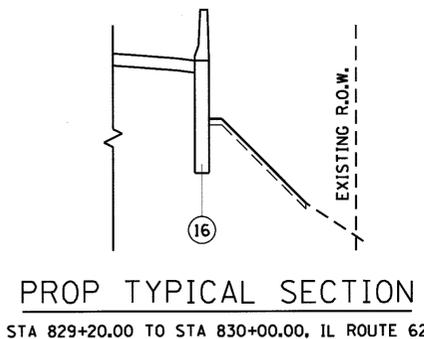
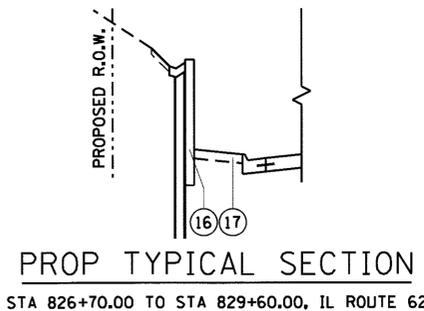
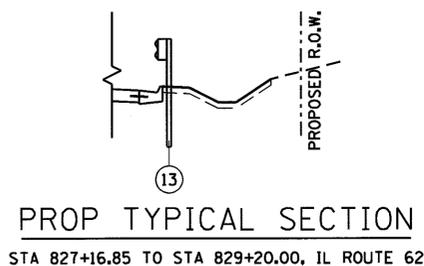
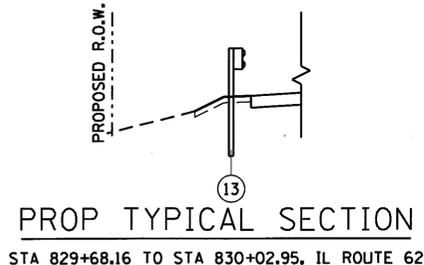

STA	SLOPE
817+30.98 TO 817+45.39	TRANSITION TO 0.0%
817+45.39 TO 819+87.82	TRANSITION TO 5.2% LEFT
819+87.82 TO STA 820+45.92	5.2% LEFT

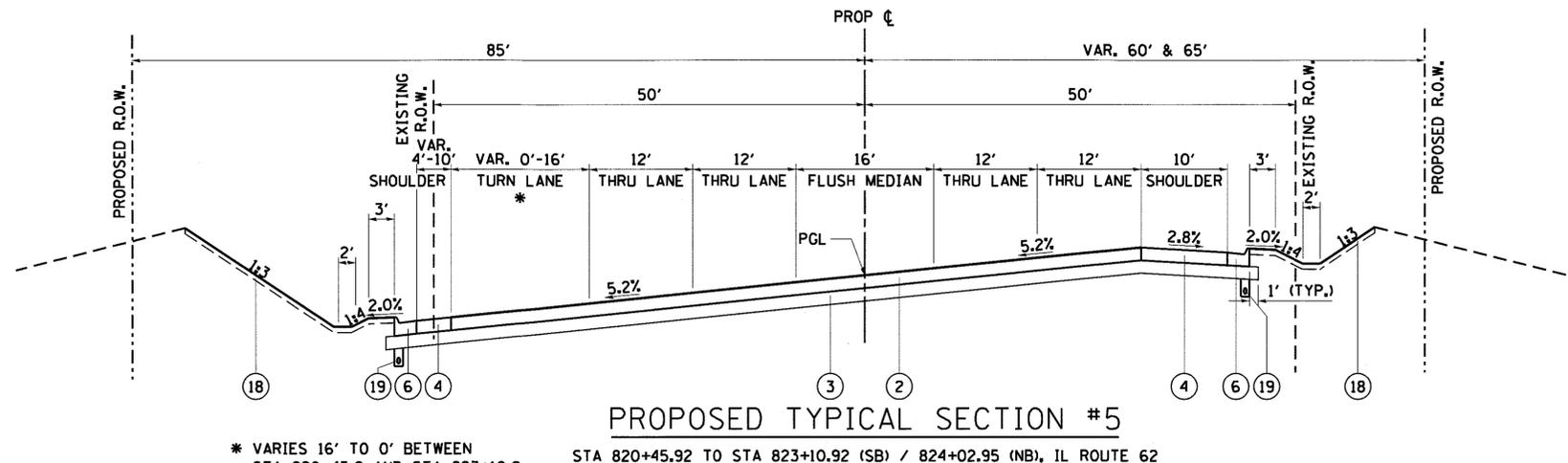

* VARIES 16' TO 0' BETWEEN STA 820+45.9 AND STA 823+10.9

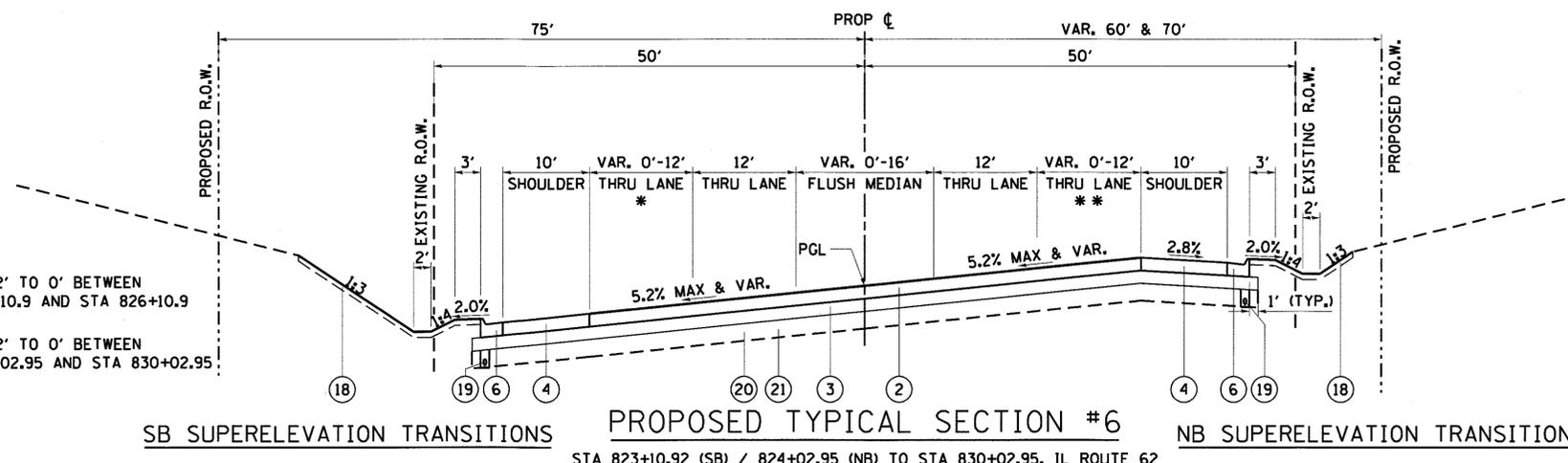

* VARIES 12' TO 0' BETWEEN STA 823+10.9 AND STA 826+10.9

** VARIES 12' TO 0' BETWEEN STA 824+02.95 AND STA 830+02.95

STA	SLOPE
823+10.92 TO 829+96.95	5.2% LEFT
829+96.95 TO 830+02.95	TRANSITION TO EXISTING AT CONST. LIMIT

STA	SLOPE
824+02.95 TO 829+11.95	5.2% LEFT
829+11.95 TO 830+02.95	TRANSITION TO EXISTING AT CONST. LIMIT

FILE NAME = 74754-ah-typical05.dgn



USER NAME = rjiang
PLOT SCALE = 20.0000' / 1" =
PLOT DATE = 9/26/2017

DESIGNED - MAP
DRAWN - RGJ
CHECKED - RMG
DATE - 9/5/2017

REVISED -
REVISED -
REVISED -
REVISED -

STATE OF ILLINOIS
DEPARTMENT OF TRANSPORTATION

PROPOSED TYPICAL SECTIONS
ILLINOIS ROUTE 62

SCALE: SHEET 5 OF 5 SHEETS STA. 817+30.98 TO STA. 830+02.95

F.A.U. RTE.	SECTION	COUNTY	TOTAL SHEETS	SHEET NO.
2298	13-00215-30-PV	KANE	177	19

CONTRACT NO. 61D16
ILLINOIS FED. AID PROJECT

LONGMEADOW PARKWAY SUPERELEVATION DIAGRAM

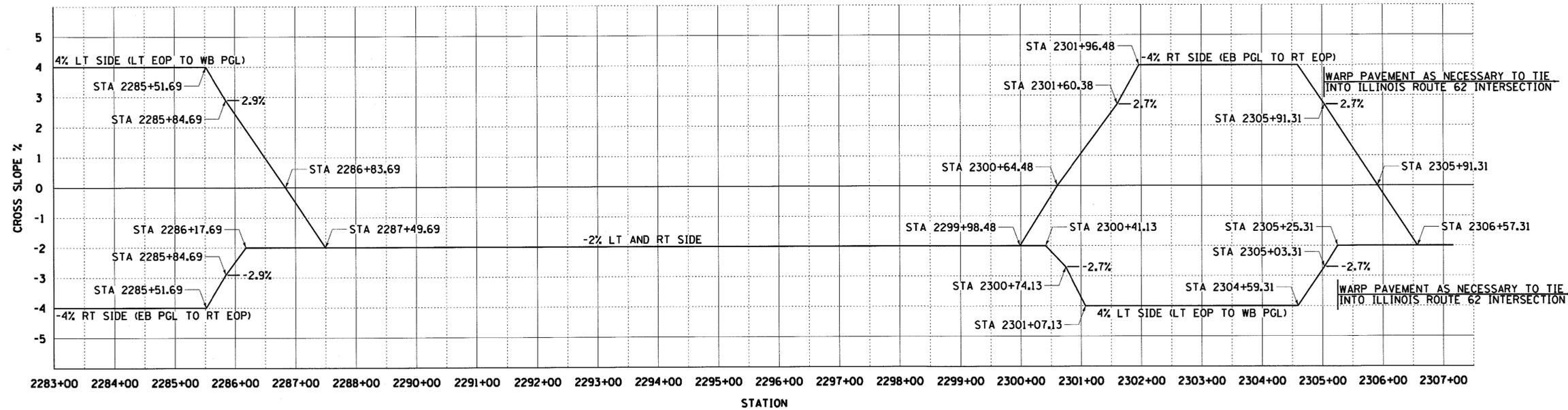

ILLINOIS ROUTE 62 SUPERELEVATION DIAGRAM

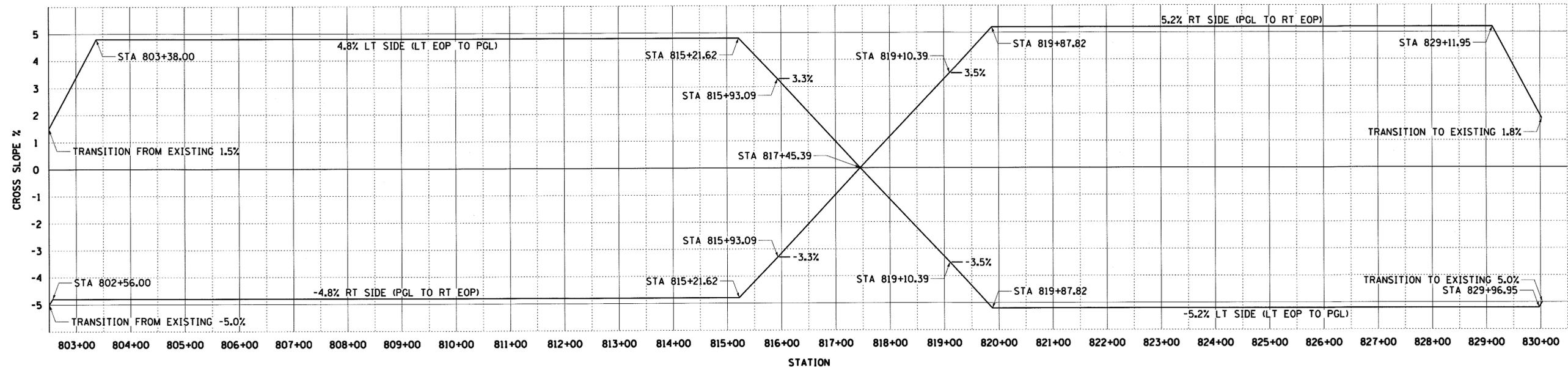

FILE NAME = 74754-shr-supr.dgn

	USER NAME = r.jiang	DESIGNED - N/A	REVISED -	STATE OF ILLINOIS DEPARTMENT OF TRANSPORTATION	SUPERELEVATION DIAGRAMS			F.A.U. RTE. = 2298	SECTION = 13-00215-30-PV	COUNTY = KANE	TOTAL SHEETS = 177	SHEET NO. = 20
	PLOT SCALE = 2.0000' / 1" =	CHECKED - RMG	REVISED -		SCALE:	SHEET 1 OF 1 SHEETS	STA. TO STA.	CONTRACT NO. 61D16				
	PLOT DATE = 9/1/2017	DATE = 9/5/2017	REVISED -		ILLINOIS FED. AID PROJECT							

REMOVALS

ROUTE	FROM	TO	TREE REMOVAL 16 TO 15 UNITS DIAMETER	TREE REMOVAL (OVER 15 UNITS DIAMETER)	TREE REMOVAL, ACRES	TEMPORARY FENCE	PAVEMENT REMOVAL	DRIVEWAY PAVEMENT REMOVAL	COMBINATION CURB AND GUTTER REMOVAL	PAVED DITCH REMOVAL	PAVED SHOULDER REMOVAL	GUARDRAIL REMOVAL	REMOVE SIGN PANEL ASSEMBLY - TYPE A	FENCE REMOVAL
	STATION	STATION	UNIT	UNIT	ACRE	FOOT	SO YD	SO YD	FOOT	FOOT	SO YD	FOOT	EACH	FOOT
LONGMEADOW PARKWAY	2283+00	2296+50	0	0	5.17	2,823	0	0	0	0	0	0	0	0
LONGMEADOW PARKWAY	2296+50	2307+17	134	176	2.03	1,978	2,749	254	263	0	0	0	5	0
IL 62	794+00	802+00	0	0	0.06	31	0	0	0	0	0	0	1	0
IL 62	802+00	815+50	84	19	1.12	2,228	4,706	70	9	0	0	858	8	423
IL 62	815+50	830+50	0	0	1.10	2,222	3,638	328	1,274	43	1,224	231	3	748
IL 62	830+50	835+00	0	0	0.12	302	0	0	0	0	0	593	0	0
MOT	-	-	0	0	0	0	4,852	0	0	0	0	0	0	0
TOTALS			218	195	9.75	9,584	15,945	652	1,546	43	1,224	1,682	17	1,171

DRAINAGE REMOVALS

ROUTE	FROM	TO	CONCRETE HEADWALL REMOVAL	PIPE CULVERT REMOVAL	STORM SEWER REMOVAL 18"	STORM SEWER REMOVAL 24"	MANHOLES TO BE RECONSTRUCTED	REMOVING MANHOLES	REMOVING CATCH BASINS
	STATION	STATION	EACH	FOOT	FOOT	FOOT	EACH	EACH	EACH
LONGMEADOW PARKWAY	2283+00	2296+50	0	0	0	0	0	0	0
LONGMEADOW PARKWAY	2296+50	2307+17	0	21	350	0	0	0	0
IL 62	794+00	802+00	0	0	0	0	0	0	0
IL 62	802+00	815+50	2	181	609	10	0	3	1
IL 62	815+50	830+50	0	19	1,037	0	1	1	0
IL 62	830+50	835+00	0	0	0	0	0	0	0
MOT	-	-	0	0	0	0	0	0	0
TOTALS			2	221	1,996	10	1	4	1

PAVEMENT MARKING

ROUTE	FROM	TO	TERMINAL MARKER - DIRECT APPLIED	PREFORMED PLASTIC PAVEMENT MARKING, TYPE B - LETTERS AND SYMBOLS	PREFORMED PLASTIC PAVEMENT MARKING, TYPE B - LINE 4"	PREFORMED PLASTIC PAVEMENT MARKING, TYPE B - LINE 6"	PREFORMED PLASTIC PAVEMENT MARKING, TYPE B - LINE 8"	PREFORMED PLASTIC PAVEMENT MARKING, TYPE B - LINE 12"	PREFORMED PLASTIC PAVEMENT MARKING, TYPE B - LINE 24"	MODIFIED URETHANE PAVEMENT MARKING - LETTERS AND SYMBOLS	MODIFIED URETHANE PAVEMENT MARKING - LINE 4"	MODIFIED URETHANE PAVEMENT MARKING - LINE 6"	MODIFIED URETHANE PAVEMENT MARKING - LINE 12"	GUARDRAIL REFLECTORS, TYPE A
	STATION	STATION	EACH	SO FT	FOOT	FOOT	FOOT	FOOT	SO	FOOT	FOOT	FOOT	FOOT	EACH
LONGMEADOW PARKWAY	2283+00	2296+50	0	0	0	0	0	0	0	0	3,375	0	0	0
LONGMEADOW PARKWAY	2296+50	2307+17	0	0	1,915	431	350	30	159	182	2,177	737	258	0
IL 62	-	802+00	0	0	1,661	0	0	0	0	0	0	0	0	0
IL 62	802+00	815+50	0	118	8,276	200	0	92	19	0	0	0	0	0
IL 62	815+50	830+50	1	192	6,931	354	0	112	0	0	0	0	0	13
IL 62	830+50	-	3	0	1,627	0	0	0	0	0	0	0	0	27
TOTALS			4	310	20,410	985	350	234	178	182	5,552	737	258	40

SIGNING

ROUTE	FROM	TO	DELINEATORS	SIGN PANEL - TYPE 1	SIGN PANEL - TYPE 2	METAL POST - TYPE A	METAL POST - TYPE B
	STATION	STATION	EACH	SO FT	SO FT	FOOT	FOOT
LONGMEADOW PARKWAY	2283+00	2296+50	0	0	0	0	0
LONGMEADOW PARKWAY	2296+50	2307+17	0	65	10	129	56
IL 62	794+00	802+00	0	8	0	27	0
IL 62	802+00	815+50	5	30	0	27	44
IL 62	815+50	830+50	5	31	0	54	30
IL 62	830+50	835+00	0	7	0	0	14
TRAFFIC SIGNALS			0	0	39	0	0
TOTALS			10	141	49	237	144

EROSION CONTROL

STAGE	FROM	TO	MULCH, METHOD 2	TEMPORARY EROSION CONTROL SEEDING	TEMPORARY DITCH CHECKS	INLET FILTERS	SEDIMENT CONTROL, STABILIZED CONSTRUCTION ENTRANCE REMOVAL	SEDIMENT CONTROL, STABILIZED CONSTRUCTION ENTRANCE MAINTENANCE	HEAVY DUTY EROSION CONTROL BLANKET, SPECIAL	EROSION CONTROL BLANKET (MODIFIED)	PERIMETER EROSION BARRIER, SPECIAL	TEMPORARY AGGREGATE BERM-COURSE AGGREGATE	TEMPORARY AGGREGATE BERM-RIP RAP	SEDIMENT CONTROL, STABILIZED CONSTRUCTION ENTRANCE	SEDIMENT CONTROL, DRAINAGE STRUCTURE, INLET FILTER CLEANING
	STATION	STATION	ACRE	POUND	FOOT	EACH	EACH	SO YD	SO YD	SO YD	FOOT	TON	TON	SO YD	EACH
STAGE 1	2283+00	2296+50	5.50	538	210	35	0	0	9,597	16,392	1496	0	0	0	105
	2296+50	2306+25	1.50	138	49	14	0	0	0	6,664	199	0	0	0	42
	794+00	802+00	0.25	10	0	0	1	220	0	480	204	0	0	220	0
	802+00	815+50	1.25	114	0	0	0	0	0	5,518	1068	0	0	0	0
	815+50	830+50	1.50	143	0	0	1	367	0	6,898	808	0	0	367	0
830+50	835+00	0.25	11	0	0	1	220	0	510	256	0	0	220	0	
STAGE 2	2283+00	2296+50	0.00	0	0	0	0	0	0	0	0	0	0	0	0
	2296+50	2306+25	1.50	132	77	17	0	0	0	6,345	0	0	0	0	51
	794+00	802+00	0.25	7	0	0	1	234	0	334	0	0	0	234	0
	802+00	815+50	1.25	101	77	7	0	0	0	4,851	621	13	13	0	21
	815+50	830+50	1.00	92	105	15	3	1008	0	4,422	50	0	0	1008	45
830+50	835+00	0.25	9	0	0	0	0	0	399	127	0	0	0	0	
STAGE 3	794+00	802+00	0.00	0	0	0	1	234	0	0	0	0	0	234	0
	802+00	815+50	0.75	72	35	12	0	0	0	3,483	0	0	0	0	36
	815+50	830+50	1.00	91	42	15	1	227	0	4,378	0	0	0	227	45
	830+50	835+00	0.25	12	0	0	0	0	0	560	0	0	0	0	0
TOTALS			16.50	1,470	595	115	9	2,510	9,597	61,234	4,829	13	13	2,510	345

LANDSCAPING

ROUTE	FROM	TO	COMPOST FURNISH AND PLACE, 2"	SEEDING, CLASS 2A	NITROGEN FERTILIZER NUTRIENT	POTASSIUM FERTILIZER NUTRIENT	STONE RIPRAP, CLASS A4	STONE DUMPED RIPRAP, CLASS A6	FILTER FABRIC	ARTICULATED BLOCK REVETMENT MAT	SEEDING CLASS, 3 (SPECIAL)	SEEDING CLASS, 4A	SEEDING CLASS, 4B	MOWING (SPECIAL)
	STATION	STATION	SO YD	ACRE	POUND	POUND	TON	TON	SO YD	SO YD	ACRE	ACRE	ACRE	ACRE
LMP	BEGIN	2285+00	2350	0.75	68	68	599	0	899	0	1	0.50	0.25	107.50
LMP	2285+00	2293+00	0	1	90	90	0	0	0	0	0.5	0	0	34.50
LMP	2293+00	2301+00	0	1	90	90	0	0	0	0	0.75	0	0	75.25
LMP	2301+00	2307+16.89	0	1.25	113	113	0	0	0	0	0.25	0	0	64.50
IL 62	794+00	802+00	0	0.25	23	23	0	0	0	0	0	0	0	10.75
IL 62	802+00	815+50	0	2.25	203	203	17	0	25	0	0	0	0	96.75
IL 62	815+50	830+50	0	1.25	135	135	105	0	407	250	0	0	0	53.75
IL 62	830+50	835+00	0	0.25	23	23	0	42	25	0	0	0	0	10.75
EROSION CONTROL							34	0	50	0				
TOTALS			2,350	8.00	745	745	755	42	1,406	250	2.50	0.50	0.25	453.75

FILE NAME = 74754-shr-sched01.dgn

	USER NAME = rjjiang	DESIGNED - RGJ	REVISED -	STATE OF ILLINOIS DEPARTMENT OF TRANSPORTATION	SCHEDULE OF QUANTITIES			F.A.U. RTE. = 2298	SECTION = 13-00215-30-PV	COUNTY = KANE	TOTAL SHEETS = 177	SHEET NO. = 21
	PLOT SCALE = 2,000' / 1" =	CHECKED - RMG	REVISED -					CONTRACT NO. 61D16				
	PLOT DATE = 9/29/2017	DATE = 9/5/2017	REVISED -					ILLINOIS FED. AID PROJECT				
	SCALE: SHEET 1 OF 3 SHEETS STA. TO STA.											

ROADWAY

ROUTE	FROM STATION	TO STATION	AGGREGATE SUBGRADE IMPROVEMENT 12"	SUBBASE GRANULAR MATERIAL, TYPE B 4"	AGGREGATE BASE COURSE, TYPE B 6"	HOT-MIX ASPHALT BASE COURSE, 6"	BITUMINOUS MATERIALS (PRIME COAT)	HOT-MIX ASPHALT BINDER COURSE, IL-19.0, NS0	HOT-MIX ASPHALT SURFACE COURSE, MIX "D", NS0	BITUMINOUS MATERIALS (TACK COAT)	HOT-MIX ASPHALT PAVEMENT (FULL-DEPTH, 10 1/4"	PORTLAND CEMENT CONCRETE PAVEMENT 10" (JOINTED)	PROTECTIVE COAT	PORTLAND CEMENT CONCRETE SIDEWALK 5 INCH	DETECTABLE WARNINGS	AGGREGATE SHOULDER, TYPE B 4"	HOT-MIX ASPHALT SHOULDERS, 10 1/4"	CLASS S1 CONCRETE (OUTLET)	CONCRETE GUTTER, TYPE B	COMBINATION CONCRETE CURB AND GUTTER, TYPE B-6.12	COMBINATION CONCRETE CURB AND GUTTER, TYPE B-6.24	COMBINATION CONCRETE CURB AND GUTTER, TYPE M-4.24	CONCRETE MEDIAN SURFACE, 4 INCH	CONCRETE MEDIAN, TYPE SB-6.12	STEEL PLATE BEAM GUARDRAIL, TYPE A, 6 FOOT POSTS	TRAFFIC BARRIER TERMINAL, TYPE 6	TRAFFIC BARRIER TERMINAL, TYPE 1 (SPECIAL) TANGENT	BARRIER WALL REFLECTORS, TYPE C
			SO YD	SO YD	SO YD	SO YD	SO YD	SO YD	SO YD	SO YD	SO YD	SO YD	SO YD	SO YD	SO FT	SO FT	SO YD	SO YD	CU YD	FOOT	FOOT	FOOT	FOOT	SO FT	SO FT	FOOT	EACH	EACH
LONGMEADOW PARKWAY	2283+00	2296+50	8,449	0	1,798	0	4,046	0	252	0	6,601	8,150	0	0	0	0	0	0	2,701	2,701	0	0	0	0	0	0	0	0
LONGMEADOW PARKWAY	2296+50	2307+16.89	12,092	48	1,266	181	2,849	31	224	2,053	3,849	5,809	7,378	430	60	37	497	0	1,321	2,194	506	492	2,212	0	0	0	0	
IL 62	802+00	815+50	11,563	0	0	203	0	0	23	4,800	7,671	0	834	0	0	0	2,892	2	0	0	2,569	0	0	0	0	0	0	
IL 62	815+50	830+50	10,003	0	0	210	0	0	25	4,174	6,895	0	915	0	0	0	2,195	3	286	0	2,091	1,550	0	712.5	2	4	6	
MOT	-	-	4,852	0	0	0	0	0	0	0	0	0	0	0	0	0	0	0	0	0	0	0	0	0.0	0	0	599	
TOTALS			46,959	48	3,064	594	6,895	31	524	11,027	18,415	12,410	17,277	430	60	37	5,584	5	286	4,022	4,895	5,166	2,042	2,212	712.5	2	4	605

MAINTENANCE OF TRAFFIC

STAGE	FROM STATION	TO STATION	TEMPORARY PAVEMENT MARKING - LINE 6"	PAVEMENT MARKING TAPE, TYPE IV 4"	TEMPORARY CONCRETE BARRIER	RELOCATE TEMPORARY CONCRETE BARRIER	IMPACT ATTENUATORS, TEMPORARY (SEVERE USE NARROW) TEST LEVEL 3	IMPACT ATTENUATORS, RELOCATE (SEVERE USE NARROW) TEST LEVEL 3	BARRIER WALL REFLECTORS, TYPE C	PAVEMENT MARKING REMOVAL - GRINDING	TEMPORARY ACCESS (PRIVATE ENTRANCE)	TEMPORARY ACCESS (ROAD)	TEMPORARY PAVEMENT MARKING REMOVAL	PINNING TEMPORARY CONCRETE BARRIER	TEMPORARY INFORMATION SIGNING	TEMPORARY PAVEMENT
			FOOT	FOOT	FOOT	FOOT	EACH	EACH	EACH	SO FT	EACH	EACH	SO FT	EACH	SO FT	SO YD
STAGE 1	794+00	802+00	313.0	1,687	312.5	0.0	1	0	25	155	0	0	563	103	134	224
	802+00	815+50	1,350.0	4,919	1,350.0	0.0	0	0	108	673	1	0	1,640	432	13	1,562
	815+50	830+50	1,513.0	5,742	1,512.5	0.0	0	0	121	753	3	0	1,914	484	0	1,676
	830+50	835+00	313.0	1,623	312.5	0.0	1	0	25	155	0	0	541	103	112	340
	SUBTOTAL		3,489.0	13,971	3,487.5	0.0	2	0	279	1,736	4	0	4,658	1,122	259	3,802
STAGE 2	794+00	802+00	0.0	1,628	0.0	0.0	1	0	0	0	0	0	543	0	32.5	165
	802+00	815+50	1,175.0	4,896	0.0	1,175.0	2	0	94	588	0	1	1,632	388	26.25	226
	815+50	830+50	1,525.0	5,936	0.0	1,525.0	4	1	122	763	1	1	1,979	500	70	562
	830+50	835+00	438.0	1,628	0.0	437.5	1	1	35	219	0	0	543	146	32.5	97
	SUBTOTAL		3,138.0	14,088	0.0	3,137.5	8	2	251	1,570	1	2	4,697	1,034	161	1,050
STAGE 3	794+00	802+00	0.0	1,192	0.0	0.0	0	0	0	0	0	0	398	0	32.5	0
	802+00	815+50	238.0	4,957	0.0	237.5	0	2	19	119	1	0	1,653	82	26.25	0
	815+50	830+50	363.0	5,471	0.0	362.5	0	1	29	182	2	0	1,824	119	45	0
	830+50	835+00	263.0	1,319	0.0	262.5	0	1	21	132	0	0	440	87	32.5	0
	SUBTOTAL		864.0	12,939	0.0	862.5	0	4	69	433	3	0	4,315	288	136	0
STAGE 4	794+00	802+00	0.0	600	0.0	0.0	0	0	0	0	0	0	200	0	0	0
	802+00	815+50	0.0	2,743	0.0	0.0	0	0	0	0	0	0	915	0	0	0
	815+50	830+50	0.0	2,958	0.0	0.0	0	0	0	0	0	0	986	0	0	0
	830+50	835+00	0.0	500	0.0	0.0	0	0	0	0	0	0	167	0	0	0
	SUBTOTAL		0.0	6,801	0.0	0.0	0	0	0	0	0	0	2,268	0	0	0
INTERIM	-	-	0.0	0	0.0	0.0	0	0	0	0	0	0	0	60	0	
ROADWAY	-	-	0.0	0	0.0	0.0	0	0	6	0	0	0	0	0	0	
TOTALS			7,491	47,799	3,488	4,000	10	6	605	3,739	8	2	15,938	2,444	617	4,852

FILE NAME = 74754-ah-techno02.dgn



USER NAME = r.jiang
 PLOT SCALE = 2.0000' / 1" =
 PLOT DATE = 9/26/2017

DESIGNED - RGJ
 DRAWN - RGJ
 CHECKED - RMG
 DATE - 9/5/2017

REVISED -
 REVISED -
 REVISED -
 REVISED -

STATE OF ILLINOIS
 DEPARTMENT OF TRANSPORTATION

SCHEDULE OF QUANTITIES

SCALE: SHEET 2 OF 3 SHEETS STA. TO STA.

F.A.U. RTE.	SECTION	COUNTY	TOTAL SHEETS	SHEET NO.
2298	13-00215-30-PV	KANE	177	22
CONTRACT NO. 61D16				
ILLINOIS FED. AID PROJECT				

EARTHWORK

ROUTE	STATION	EARTHWORK AREA (SF)				EARTHWORK VOLUME (CY)			
		CUT	FILL	TOPSOIL STRIPPING	UNSUITABLE MATERIALS	CUT	FILL	TOPSOIL STRIPPING	UNSUITABLE MATERIALS
		LONGMEADOW PARKWAY	2282+50	0.0	0.0	0.0	0.0		
LONGMEADOW PARKWAY	2283+00	0.9	957.1	75.2	0.0	1	887	69	0
LONGMEADOW PARKWAY	2283+50	14.3	1,544.9	110.6	0.0	15	2,317	172	0
LONGMEADOW PARKWAY	2284+00	2.1	1,327.7	108.4	0.0	16	2,660	202	0
LONGMEADOW PARKWAY	2284+50	0.9	964.1	98.1	0.0	3	2,123	191	0
LONGMEADOW PARKWAY	2285+00	16.3	424.0	87.2	0.0	16	1,286	171	0
LONGMEADOW PARKWAY	2285+50	150.8	177.2	89.7	0.0	155	557	163	0
LONGMEADOW PARKWAY	2286+00	228.8	22.4	81.9	0.0	352	185	158	0
LONGMEADOW PARKWAY	2286+50	108.7	19.3	80.9	0.0	313	39	150	0
LONGMEADOW PARKWAY	2287+00	260.8	7.2	86.9	0.0	343	25	155	0
LONGMEADOW PARKWAY	2287+50	294.4	51.5	101.8	0.0	515	55	174	0
LONGMEADOW PARKWAY	2288+00	170.3	239.9	108.2	0.0	431	270	194	0
LONGMEADOW PARKWAY	2288+50	15.8	530.1	108.8	0.0	173	713	200	0
LONGMEADOW PARKWAY	2289+00	0.6	602.5	115.4	0.0	16	1,049	207	0
LONGMEADOW PARKWAY	2289+50	26.3	452.3	118.8	0.0	25	977	216	0
LONGMEADOW PARKWAY	2290+00	56.3	391.2	110.4	0.0	77	782	212	0
LONGMEADOW PARKWAY	2290+50	47.2	540.9	124.1	0.0	96	864	217	0
LONGMEADOW PARKWAY	2291+00	416.6	330.4	133.0	0.0	430	807	238	0
LONGMEADOW PARKWAY	2291+50	616.4	300.3	132.9	0.0	957	584	246	0
LONGMEADOW PARKWAY	2292+00	572.7	254.4	131.6	0.0	1,102	514	244	0
LONGMEADOW PARKWAY	2292+50	115.4	302.6	126.6	88.4	638	516	239	82
LONGMEADOW PARKWAY	2293+00	6.4	414.4	129.9	85.2	113	664	237	161
LONGMEADOW PARKWAY	2293+50	1.4	830.6	130.4	90.2	8	1,153	241	163
LONGMEADOW PARKWAY	2294+00	1.3	967.4	128.5	93.5	3	1,665	239	171
LONGMEADOW PARKWAY	2294+50	2.9	1,180.5	130.4	96.0	4	1,989	239	176
LONGMEADOW PARKWAY	2295+00	8.5	1,004.7	131.3	93.0	11	2,024	242	175
LONGMEADOW PARKWAY	2295+50	37.7	675.8	125.6	86.0	43	1,557	237	166
LONGMEADOW PARKWAY	2296+00	31.4	901.3	127.2	0.0	64	1,461	234	80
LONGMEADOW PARKWAY	2296+50	1.8	1,410.2	134.5	0.0	31	2,141	242	0
LONGMEADOW PARKWAY	2297+00	0.7	1,266.5	120.6	0.0	3	2,479	236	0
LONGMEADOW PARKWAY	2297+50	1.6	1,024.2	117.0	0.0	3	2,122	220	0
LONGMEADOW PARKWAY	2298+00	41.2	833.1	115.5	0.0	40	1,720	215	0
LONGMEADOW PARKWAY	2298+50	74.2	562.3	112.9	0.0	107	1,293	211	0
LONGMEADOW PARKWAY	2299+00	156.7	457.3	147.7	0.0	214	945	241	0
LONGMEADOW PARKWAY	2299+50	27.1	178.8	84.9	0.0	171	589	215	0
LONGMEADOW PARKWAY	2300+00	115.6	6.2	71.5	0.0	133	172	144	0
LONGMEADOW PARKWAY	2300+50	243.8	1.1	80.9	0.0	333	7	141	0
LONGMEADOW PARKWAY	2301+00	261.7	0.1	79.9	0.0	469	2	148	0
LONGMEADOW PARKWAY	2301+50	303.0	0.1	85.4	0.0	523	1	153	0
LONGMEADOW PARKWAY	2302+00	475.9	0.1	88.1	0.0	722	1	160	0
LONGMEADOW PARKWAY	2302+50	583.8	0.1	92.3	0.0	982	1	167	0
LONGMEADOW PARKWAY	2303+00	632.7	0.1	92.9	0.0	1,127	1	171	0
LONGMEADOW PARKWAY	2303+50	665.8	0.1	94.2	0.0	1,203	1	173	0
LONGMEADOW PARKWAY	2304+00	673.8	0.0	99.5	0.0	1,241	1	179	0
LONGMEADOW PARKWAY	2304+50	486.3	6.1	112.9	0.0	1,075	6	196	0
LONGMEADOW PARKWAY	2305+00	277.6	10.2	121.1	0.0	708	16	216	0
LONGMEADOW PARKWAY	2305+50	196.3	12.8	127.4	0.0	439	22	230	0
LONGMEADOW PARKWAY	2306+00	294.2	14.5	132.9	0.0	455	26	241	0
		TOTAL	15,899	39,269	9,386	1,174			

ROUTE	STATION	EARTHWORK AREA (SF)				EARTHWORK VOLUME (CY)			
		CUT	FILL	TOPSOIL STRIPPING	UNSUITABLE MATERIALS	CUT	FILL	TOPSOIL STRIPPING	UNSUITABLE MATERIALS
		BASIN		-	-	-	-	32,725	1,582
		TOTAL	32,725	1,582	1,577	0			
		GRAND TOTAL	59,823	49,793	16,845	10,278			

ROUTE	STATION	EARTHWORK AREA (SF)				EARTHWORK VOLUME (CY)			
		CUT	FILL	TOPSOIL STRIPPING	UNSUITABLE MATERIALS	CUT	FILL	TOPSOIL STRIPPING	UNSUITABLE MATERIALS
		IL ROUTE 62	802+50	35.8	8.1	25.0	0.0		
IL ROUTE 62	803+00	33.2	3.1	28.9	0.0	64	11	49	0
IL ROUTE 62	803+50	29.3	7.8	30.6	0.0	58	11	55	0
IL ROUTE 62	804+00	47.2	6.8	43.1	0.0	71	14	68	0
IL ROUTE 62	804+50	34.7	12.5	39.4	0.0	76	18	76	0
IL ROUTE 62	805+00	28.4	14.6	38.6	0.0	59	26	72	0
IL ROUTE 62	805+50	71.3	8.9	47.3	0.0	93	22	79	0
IL ROUTE 62	806+00	152.9	4.6	58.9	0.0	208	13	98	0
IL ROUTE 62	806+50	254.5	0.3	64.9	0.0	378	5	114	0
IL ROUTE 62	807+00	149.1	1.4	53.3	0.0	374	2	109	0
IL ROUTE 62	807+50	60.6	2.9	43.1	183.2	195	4	89	170
IL ROUTE 62	808+00	8.5	108.6	63.2	165.6	64	104	98	323
IL ROUTE 62	808+50	26.0	275.2	76.8	163.1	32	356	129	305
IL ROUTE 62	809+00	52.7	306.0	82.7	178.3	73	539	147	317
IL ROUTE 62	809+50	75.0	291.2	83.1	187.7	119	553	153	339
IL ROUTE 62	810+00	76.8	283.6	81.5	198.7	141	533	152	358
IL ROUTE 62	810+50	29.2	259.4	79.4	194.4	99	503	148	364
IL ROUTE 62	811+00	0.4	239.2	69.2	186.2	28	462	137	353
IL ROUTE 62	811+50	0.0	203.7	64.7	179.6	1	411	123	339
IL ROUTE 62	812+00	0.0	203.0	65.4	163.1	0	377	120	318
IL ROUTE 62	812+50	0.0	240.6	66.6	153.4	0	411	122	293
IL ROUTE 62	813+00	0.0	298.6	72.1	146.8	0	500	128	278
IL ROUTE 62	813+50	0.4	337.3	78.5	134.0	1	589	139	260
IL ROUTE 62	814+00	9.4	221.8	74.5	123.4	10	518	141	239
IL ROUTE 62	814+50	35.2	70.9	68.4	119.2	42	272	132	225
IL ROUTE 62	815+00	65.5	78.6	68.0	127.9	94	139	126	229
IL ROUTE 62	815+50	45.3	248.1	70.8	140.3	103	303	128	249
IL ROUTE 62	816+00	0.0	309.2	168.4	142.4	42	517	221	262
IL ROUTE 62	816+50	0.0	182.2	44.5	111.8	0	455	197	236
IL ROUTE 62	817+00	0.0	89.8	47.9	127.6	0	252	85	222
IL ROUTE 62	817+50	20.5	60.1	42.3	0.0	19	139	83	119
IL ROUTE 62	818+00	32.1	63.7	51.1	0.0	49	115	86	0
IL ROUTE 62	818+50	247.4	63.6	84.6	0.0	259	118	125	0
IL ROUTE 62	819+00	179.1	25.3	73.1	0.0	395	83	146	0
IL ROUTE 62	819+50	286.2	35.4	74.8	0.0	431	57	136	0
IL ROUTE 62	820+00	360.1	76.4	78.1	0.0	599	104	141	0
IL ROUTE 62	820+50	380.8	15.2	70.0	0.0	687	85	137	0
IL ROUTE 62	821+00	506.8	0.2	70.1	0.0	822	15	129	0
IL ROUTE 62	821+50	456.4	0.3	67.0	0.0	892	1	126	0
IL ROUTE 62	822+00	514.8	0.3	68.9	0.0	900	1	125	0
IL ROUTE 62	822+50	423.5	0.3	63.5	0.0	869	1	122	0
IL ROUTE 62	823+00	368.4	1.2	58.1	0.0	734	2	112	0
IL ROUTE 62	823+50	188.7	6.4	54.3	216.1	516	8	104	201
IL ROUTE 62	824+00	138.2	9.3	52.5	202.3	303	15	98	388
IL ROUTE 62	824+50	97.2	8.0	43.9	179.2	218	17	89	354
IL ROUTE 62	825+00	68.3	1.9	42.3	155.3	154	10	79	310
IL ROUTE 62	825+50	59.8	4.1	40.7	134.7	119	6	76	269
IL ROUTE 62	826+00	68.4	5.7	46.2	120.4	119	10	80	237
IL ROUTE 62	826+50	56.6	0.8	36.9	123.2	116	7	76	226
IL ROUTE 62	827+00	47.4	11.8	37.1	109.1	97	12	68	216
IL ROUTE 62	827+50	76.8	6.7	34.6	108.0	115	18	66	202
IL ROUTE 62	828+00	85.6	5.4	38.7	97.0	151	12	67	190
IL ROUTE 62	828+50	37.8	6.3	24.2	126.0	115	11	58	207
IL ROUTE 62	829+00	17.2	79.2	35.6	82.6	51	80	55	194
IL ROUTE 62	829+50	10.0	8.3	14.5	69.5	26	82	46	169
IL ROUTE 62	830+00	9.4	5.0	4.1	59.2	18	13	17	143
		TOTAL	11,199	8,942	5,882	9,104			

- NOTES**
- THE USE OF UNSUITABLE MATERIAL CAN BE USED AS FILL MATERIAL IN AREAS UNDER EMBANKMENT AND NOT UNDER THE INCLUSIVE LINES OF THE PROPOSED PAVEMENT STRUCTURE. A POTENTIAL LOCATION CAN BE THE BERM LOCATED NORTH OF LONGMEADOW PARKWAY FROM STATION 2292+00 TO 2298+00.
 - THE CONTRACTOR SHALL DETERMINE THE AMOUNT OF TOPSOIL STRIPPED FOR THIS CONTRACT TO BALANCE THE AMOUNT OF TOPSOIL NEEDED. THE EXCESS TOPSOIL MATERIAL, IF REMOVED BY THE CONTRACTOR, SHALL BE USED AS FILL MATERIAL IN AREAS OUTSIDE OF THE LIMITS OF THE PROPOSED PAVEMENT AND MULTI-USE PATH.
 - ANY ADDITIONAL TOPSOIL STRIPPING PERFORMED THAT IS NOT UTILIZED FOR TOPSOIL EXCAVATION AND PLACEMENT, SHALL BE PAID FOR AS EARTH EXCAVATION.

EARTHWORK SUMMARY													
LOCATION	EARTH EXCAVATION (+)	UNSUITABLE MATERIALS (SEE NOTE 1) (+)	STRUCTURE EXCAVATION (+)	NON SPECIAL WASTE (-)	TOTAL EXCAVATION USED FOR BACKFILL	TOPSOIL REMOVAL (SEE NOTE 2)	ADJUSTED EARTH EXCAVATION (85%)						



NOTES

1. SEE SHEET 2 OF 3 FOR MULTI-USE PATH ALIGNMENT INFORMATION.
2. SEE SHEET 3 OF 3 FOR CONTROL POINT INFORMATION.

LONGMEADOW			
POINT	STATION	NORTHING	EASTING
POT	2270+00.00	1,993,580.84	1,004,673.02
PC	2272+59.69	1,993,583.15	1,004,932.70
PI	2275+46.53	1,993,585.71	1,005,219.53
PT	2278+18.79	1,993,738.04	1,005,462.57
PC	2280+09.23	1,993,839.19	1,005,623.94
PI	2283+04.51	1,993,996.01	1,005,874.14
PT	2285+84.69	1,993,998.21	1,006,169.41
PC	2300+74.14	1,994,009.36	1,007,658.81
PI	2302+90.56	1,994,010.97	1,007,875.22
PT	2305+03.31	1,994,080.25	1,008,080.25
POT	2307+16.89	1,994,148.61	1,008,282.59

IL 62			
POINT	STATION	NORTHING	EASTING
POT	794+00.00	1,992,438.81	1,009,761.58
PC	795+19.55	1,992,492.73	1,009,654.88
PI	806+11.27	1,992,985.17	1,008,680.53
PT	815+93.09	1,994,018.14	1,008,327.22
PC	819+10.39	1,994,318.36	1,008,224.53
PI	824+78.45	1,994,855.85	1,008,040.69
PT	830+24.07	1,995,245.28	1,007,627.11
POT	835+00.00	1,995,571.54	1,007,280.62

BM*10 HLR (BENCHMARK KANE CO. 6-65) ELEV. = 890.092
 DESCRIPTION: CHISELED SQUARE ON TOP OF CURB SOUTHWEST CORNER OF IL ROUTE 62 AT AUTUMN TRAIL EAST
 NORTHING: 1,994,021.93
 EASTING: 1,008,257.22

BM*11 HLR ELEV. = 894.978
 DESCRIPTION: EAST BOLT OF FIRE HYDRANT WITH CUT "X" AT SOUTHWEST CORNER OF ALAMEDA DRIVE AND BOLZ ROAD
 NORTHING: 1,993,432.37
 EASTING: 1,004,498.03

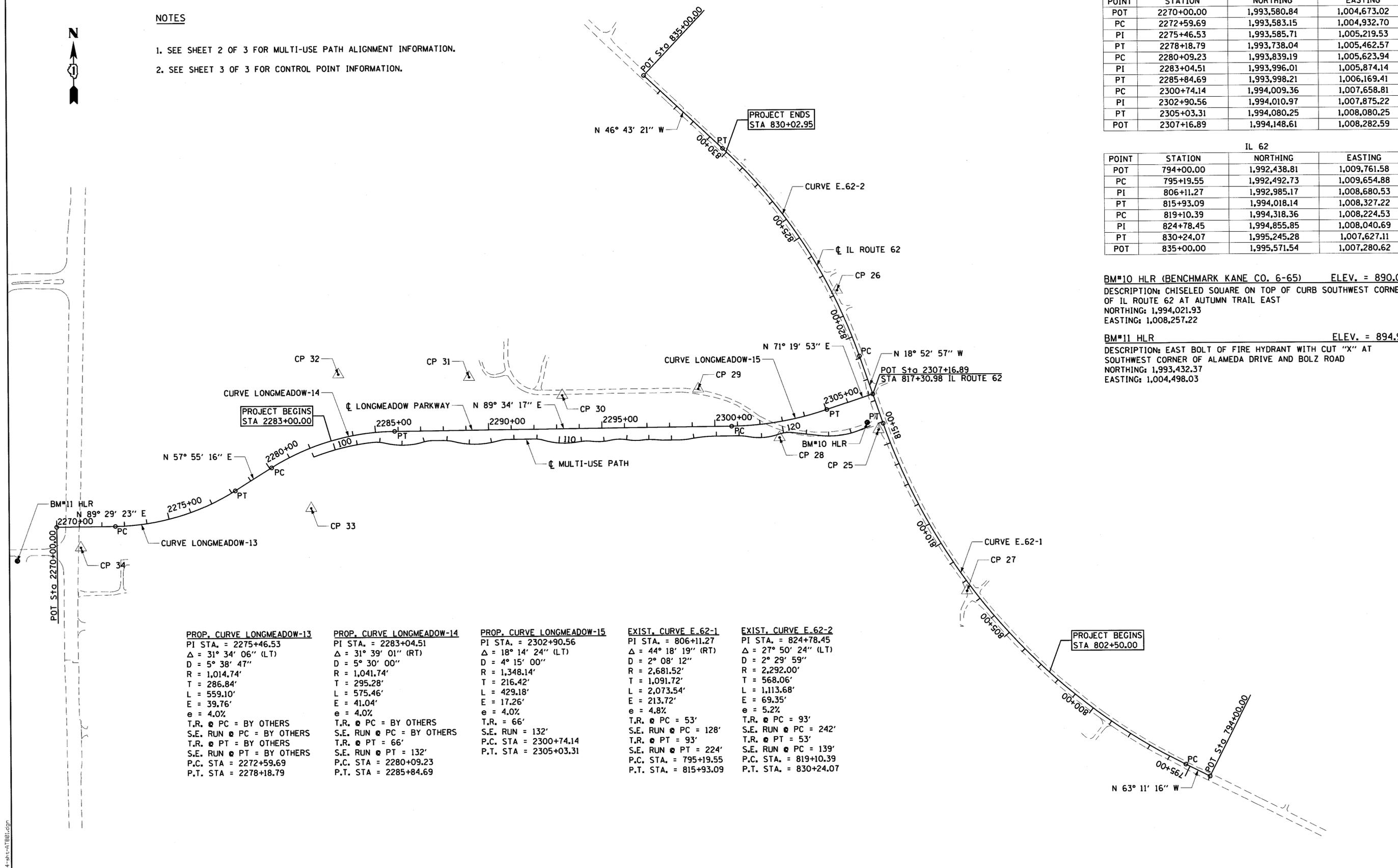

PROP. CURVE LONGMEADOW-13	PROP. CURVE LONGMEADOW-14	PROP. CURVE LONGMEADOW-15	EXIST. CURVE E.62-1	EXIST. CURVE E.62-2
PI STA. = 2275+46.53	PI STA. = 2283+04.51	PI STA. = 2302+90.56	PI STA. = 806+11.27	PI STA. = 824+78.45
Δ = 31° 34' 06" (LT)	Δ = 31° 39' 01" (RT)	Δ = 18° 14' 24" (LT)	Δ = 44° 18' 19" (RT)	Δ = 27° 50' 24" (LT)
D = 5° 38' 47"	D = 5° 30' 00"	D = 4° 15' 00"	D = 2° 08' 12"	D = 2° 29' 59"
R = 1,014.74'	R = 1,041.74'	R = 1,348.14'	R = 2,681.52'	R = 2,292.00'
T = 286.84'	T = 295.28'	T = 216.42'	T = 1,091.72'	T = 568.06'
L = 559.10'	L = 575.46'	L = 429.18'	L = 2,073.54'	L = 1,113.68'
E = 39.76'	E = 41.04'	E = 17.26'	E = 213.72'	E = 69.35'
e = 4.0%	e = 4.0%	e = 4.0%	e = 4.8%	e = 5.2%
T.R. @ PC = BY OTHERS	T.R. @ PC = BY OTHERS	T.R. = 66'	T.R. @ PC = 53'	T.R. @ PC = 93'
S.E. RUN @ PC = BY OTHERS	S.E. RUN @ PC = BY OTHERS	S.E. RUN = 132'	S.E. RUN @ PC = 128'	S.E. RUN @ PC = 242'
T.R. @ PT = BY OTHERS	T.R. @ PT = 66'	P.C. STA = 2300+74.14	T.R. @ PT = 93'	T.R. @ PT = 53'
S.E. RUN @ PT = BY OTHERS	S.E. RUN @ PT = 132'	P.T. STA = 2305+03.31	S.E. RUN @ PT = 224'	S.E. RUN @ PC = 139'
P.C. STA = 2272+59.69	P.C. STA = 2280+09.23		P.C. STA. = 795+19.55	P.C. STA. = 819+10.39
P.T. STA = 2278+18.79	P.T. STA = 2285+84.69		P.T. STA. = 815+93.09	P.T. STA. = 830+24.07

FILE NAME = 74754-01-01-01-01.dwg

MULTI-USE PATH				
CURVE	POINT	STATION	NORTHING	EASTING
PATH-1	PC	99+00.00	1,993,885.77	1,005,811.44
	PI	100+36.54	1,993,935.78	1,005,938.49
PATH-2	PCC	101+71.39	1,993,949.85	1,006,074.29
	PI	101+97.64	1,993,952.55	1,006,100.40
PATH-3	PRC	102+23.36	1,993,917.71	1,006,027.67
	PI	103+14.27	1,993,924.33	1,006,214.11
PATH-4	PRC	104+00.78	1,993,937.95	1,006,174.61
	PI	104+18.11	1,993,955.74	1,006,317.70
PATH-5	PT	104+35.21	1,993,955.87	1,006,335.03
	PC	104+82.78	1,993,956.23	1,006,382.61
PATH-6	PI	105+07.54	1,993,956.41	1,006,407.37
	PRC	105+32.03	1,993,950.25	1,006,431.35
PATH-7	PI	106+35.83	1,993,924.39	1,006,531.88
	PRC	107+34.69	1,993,953.24	1,006,631.59
PATH-8	PI	107+52.62	1,993,958.22	1,006,648.81
	PT	107+70.32	1,993,958.35	1,006,666.74
PATH-9	PC	108+91.99	1,993,959.26	1,006,788.40
	PI	109+11.31	1,993,959.41	1,006,807.73
PATH-10	PRC	109+30.33	1,993,953.71	1,006,826.20
	PI	110+08.29	1,993,930.72	1,006,900.69

CURVE	POINT	STATION	NORTHING	EASTING
PATH-10	PRC	110+83.27	1,993,944.58	1,006,977.40
	PI	111+17.10	1,993,950.59	1,007,010.69
PATH-11	PRC	111+50.42	1,993,946.54	1,007,044.28
	PI	111+88.83	1,993,941.95	1,007,082.42
PATH-12	PRC	112+26.51	1,993,950.27	1,007,119.92
	PI	112+65.69	1,993,958.76	1,007,158.17
PATH-13	PRC	113+03.89	1,993,952.19	1,007,196.79
	PI	113+38.29	1,993,946.42	1,007,230.70
PATH-14	PRC	113+72.21	1,993,950.61	1,007,264.85
	PI	114+04.66	1,993,954.56	1,007,297.05
PATH-15	PRC	114+36.80	1,993,950.91	1,007,329.30
	PI	114+53.66	1,993,949.01	1,007,346.04
PATH-16	PT	114+70.47	1,993,949.14	1,007,362.89
	PC	115+32.19	1,993,949.60	1,007,424.61
PATH-17	PI	115+61.07	1,993,949.82	1,007,453.49
	PRC	115+89.78	1,993,955.28	1,007,481.84
PATH-18	PI	116+40.21	1,993,964.82	1,007,531.36
	PT	116+90.35	1,993,965.20	1,007,581.78
PATH-19	PC	117+94.31	1,993,965.98	1,007,685.74
	PI	118+19.11	1,993,966.16	1,007,710.54

CURVE	POINT	STATION	NORTHING	EASTING
PATH-19	PRC	118+43.75	1,993,961.47	1,007,734.89
	PI	119+12.59	1,993,948.45	1,007,802.49
PATH-20	PRC	119+78.10	1,993,971.87	1,007,867.22
	PI	120+09.10	1,993,982.42	1,007,896.37
PATH-21	PT	120+38.96	1,993,978.68	1,007,927.14
	PC	121+60.06	1,993,964.06	1,008,047.35
PATH-22	PI	122+49.47	1,993,953.27	1,008,136.11
	PT	123+35.13	1,993,986.37	1,008,219.17
PATH-23	POT	123+90.95	1,994,007.04	1,008,271.02

NOTES

- SEE SHEET 1 OF 3 FOR LONGMEADOW PARKWAY AND IL ROUTE 62 INFORMATION ALIGNMENT INFORMATION.
- SEE SHEET 1 OF 3 FOR BENCHMARK INFORMATION.
- SEE SHEET 3 OF 3 FOR CONTROL POINT INFORMATION.

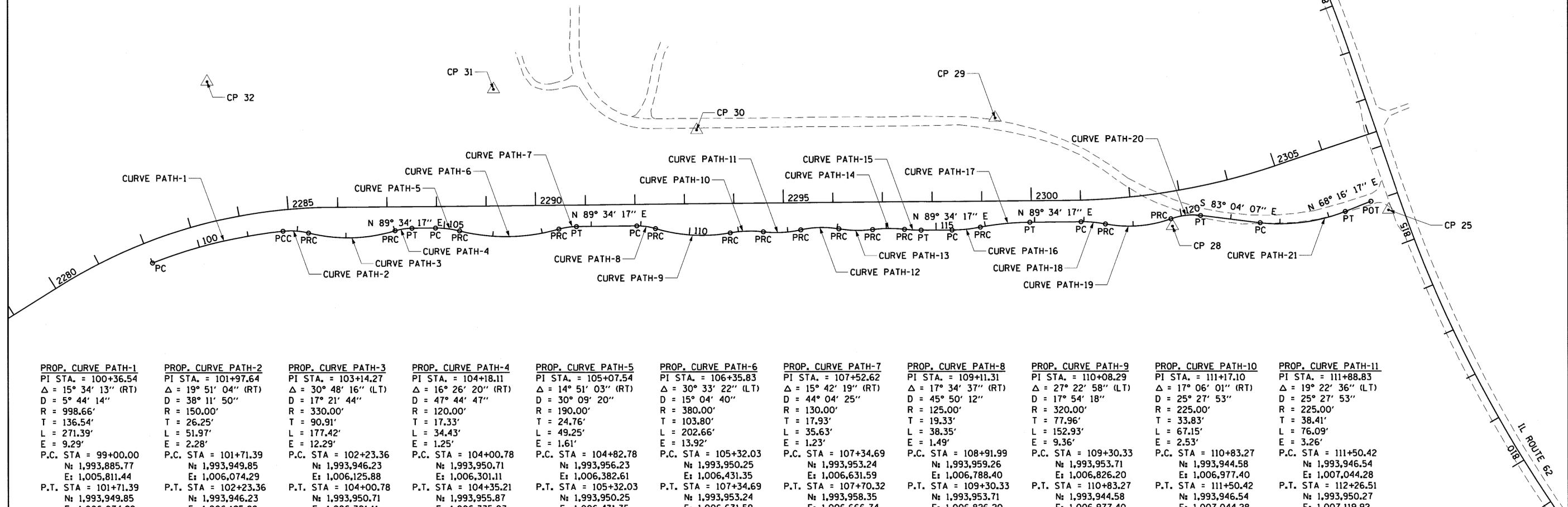

PROP. CURVE PATH-1 PI STA. = 100+36.54 $\Delta = 15^\circ 34' 13''$ (RT) $D = 5^\circ 44' 14''$ $R = 998.66'$ $T = 136.54'$ $L = 271.39'$ $E = 9.29'$ P.C. STA = 99+00.00 N: 1,993,885.77 E: 1,005,811.44 P.T. STA = 101+71.39 N: 1,993,949.85 E: 1,006,074.29	PROP. CURVE PATH-2 PI STA. = 101+97.64 $\Delta = 19^\circ 51' 04''$ (RT) $D = 38^\circ 11' 50''$ $R = 150.00'$ $T = 26.25'$ $L = 51.97'$ $E = 2.28'$ P.C. STA = 101+71.39 N: 1,993,949.85 E: 1,006,074.29 P.T. STA = 102+23.36 N: 1,993,946.23 E: 1,006,125.88	PROP. CURVE PATH-3 PI STA. = 103+14.27 $\Delta = 30^\circ 48' 16''$ (LT) $D = 17^\circ 21' 44''$ $R = 330.00'$ $T = 90.91'$ $L = 177.42'$ $E = 12.29'$ P.C. STA = 102+23.36 N: 1,993,946.23 E: 1,006,125.88 P.T. STA = 104+00.78 N: 1,993,950.71 E: 1,006,301.11	PROP. CURVE PATH-4 PI STA. = 104+18.11 $\Delta = 16^\circ 26' 20''$ (RT) $D = 47^\circ 44' 47''$ $R = 120.00'$ $T = 17.33'$ $L = 34.43'$ $E = 1.25'$ P.C. STA = 104+00.78 N: 1,993,950.71 E: 1,006,301.11 P.T. STA = 104+35.21 N: 1,993,955.87 E: 1,006,335.03	PROP. CURVE PATH-5 PI STA. = 105+07.54 $\Delta = 14^\circ 51' 03''$ (RT) $D = 30^\circ 09' 20''$ $R = 190.00'$ $T = 24.76'$ $L = 49.25'$ $E = 1.61'$ P.C. STA = 104+82.78 N: 1,993,956.23 E: 1,006,382.61 P.T. STA = 105+32.03 N: 1,993,950.25 E: 1,006,431.35	PROP. CURVE PATH-6 PI STA. = 106+35.83 $\Delta = 30^\circ 33' 22''$ (LT) $D = 15^\circ 04' 40''$ $R = 380.00'$ $T = 103.80'$ $L = 202.66'$ $E = 13.92'$ P.C. STA = 105+32.03 N: 1,993,950.25 E: 1,006,431.35 P.T. STA = 107+34.69 N: 1,993,953.24 E: 1,006,631.59	PROP. CURVE PATH-7 PI STA. = 107+52.62 $\Delta = 15^\circ 42' 19''$ (RT) $D = 44^\circ 04' 25''$ $R = 130.00'$ $T = 17.93'$ $L = 35.63'$ $E = 1.23'$ P.C. STA = 107+34.69 N: 1,993,953.24 E: 1,006,631.59 P.T. STA = 109+30.33 N: 1,993,953.71 E: 1,006,826.20	PROP. CURVE PATH-8 PI STA. = 109+11.31 $\Delta = 17^\circ 34' 37''$ (RT) $D = 45^\circ 50' 12''$ $R = 125.00'$ $T = 19.33'$ $L = 38.35'$ $E = 1.49'$ P.C. STA = 108+91.99 N: 1,993,959.26 E: 1,006,788.40 P.T. STA = 109+30.33 N: 1,993,953.71 E: 1,006,826.20	PROP. CURVE PATH-9 PI STA. = 110+08.29 $\Delta = 27^\circ 22' 58''$ (LT) $D = 17^\circ 54' 18''$ $R = 320.00'$ $T = 77.96'$ $L = 152.93'$ $E = 9.36'$ P.C. STA = 109+30.33 N: 1,993,953.71 E: 1,006,826.20 P.T. STA = 110+83.27 N: 1,993,944.58 E: 1,006,977.40	PROP. CURVE PATH-10 PI STA. = 111+17.10 $\Delta = 17^\circ 06' 01''$ (RT) $D = 25^\circ 27' 53''$ $R = 225.00'$ $T = 33.83'$ $L = 67.15'$ $E = 2.53'$ P.C. STA = 110+83.27 N: 1,993,944.58 E: 1,006,977.40 P.T. STA = 111+50.42 N: 1,993,946.54 E: 1,007,044.28	PROP. CURVE PATH-11 PI STA. = 111+88.83 $\Delta = 19^\circ 22' 36''$ (LT) $D = 25^\circ 27' 53''$ $R = 225.00'$ $T = 38.41'$ $L = 76.09'$ $E = 3.26'$ P.C. STA = 111+50.42 N: 1,993,946.54 E: 1,007,044.28 P.T. STA = 112+26.51 N: 1,993,950.27 E: 1,007,119.92
PROP. CURVE PATH-12 PI STA. = 112+65.69 $\Delta = 22^\circ 10' 05''$ (RT) $D = 28^\circ 38' 52''$ $R = 200.00'$ $T = 39.18'$ $L = 77.38'$ $E = 3.80'$ P.C. STA = 112+65.69 N: 1,993,950.27 E: 1,007,119.92 P.T. STA = 113+03.89 N: 1,993,952.19 E: 1,007,196.79	PROP. CURVE PATH-13 PI STA. = 113+38.29 $\Delta = 16^\circ 39' 23''$ (LT) $D = 24^\circ 22' 52''$ $R = 235.00'$ $T = 34.40'$ $L = 68.32'$ $E = 2.50'$ P.C. STA = 113+03.89 N: 1,993,952.19 E: 1,007,196.79 P.T. STA = 114+70.47 N: 1,993,950.61 E: 1,007,297.05	PROP. CURVE PATH-14 PI STA. = 114+04.66 $\Delta = 13^\circ 27' 30''$ (RT) $D = 20^\circ 50' 05''$ $R = 275.00'$ $T = 32.45'$ $L = 64.60'$ $E = 1.91'$ P.C. STA = 113+72.21 N: 1,993,950.61 E: 1,007,264.85 P.T. STA = 114+36.80 N: 1,993,950.91 E: 1,007,329.30	PROP. CURVE PATH-15 PI STA. = 114+36.80 $\Delta = 6^\circ 53' 17''$ (LT) $D = 20^\circ 27' 46''$ $R = 280.00'$ $T = 16.85'$ $L = 33.66'$ $E = 0.51'$ P.C. STA = 114+36.80 N: 1,993,950.91 E: 1,007,329.30 P.T. STA = 114+53.66 N: 1,993,949.01 E: 1,007,346.04	PROP. CURVE PATH-16 PI STA. = 115+61.07 $\Delta = 10^\circ 28' 36''$ (LT) $D = 18^\circ 11' 21''$ $R = 315.00'$ $T = 28.88'$ $L = 57.60'$ $E = 1.32'$ P.C. STA = 115+61.07 N: 1,993,949.82 E: 1,007,453.49 P.T. STA = 116+40.21 N: 1,993,964.82 E: 1,007,531.36	PROP. CURVE PATH-17 PI STA. = 115+89.78 $\Delta = 10^\circ 28' 36''$ (RT) $D = 10^\circ 25' 03''$ $R = 550.00'$ $T = 50.42'$ $L = 100.57'$ $E = 2.31'$ P.C. STA = 115+89.78 N: 1,993,955.28 E: 1,007,481.84 P.T. STA = 116+90.35 N: 1,993,965.20 E: 1,007,581.78	PROP. CURVE PATH-18 PI STA. = 117+94.31 $\Delta = 11^\circ 19' 49''$ (RT) $D = 22^\circ 55' 06''$ $R = 250.00'$ $T = 24.80'$ $L = 49.44'$ $E = 1.23'$ P.C. STA = 117+94.31 N: 1,993,965.98 E: 1,007,685.74 P.T. STA = 118+19.11 N: 1,993,966.16 E: 1,007,710.54	PROP. CURVE PATH-19 PI STA. = 118+43.75 $\Delta = 30^\circ 47' 29''$ (LT) $D = 22^\circ 55' 06''$ $R = 130.00'$ $T = 31.00'$ $L = 60.86'$ $E = 3.64'$ P.C. STA = 118+43.75 N: 1,993,961.47 E: 1,007,734.89 P.T. STA = 119+12.59 N: 1,993,948.45 E: 1,007,802.49	PROP. CURVE PATH-20 PI STA. = 119+78.10 $\Delta = 26^\circ 49' 17''$ (RT) $D = 16^\circ 04' 25''$ $R = 350.00'$ $T = 89.41'$ $L = 175.07'$ $E = 11.24'$ P.C. STA = 119+78.10 N: 1,993,971.87 E: 1,007,867.22 P.T. STA = 120+09.10 N: 1,993,982.42 E: 1,007,896.37	PROP. CURVE PATH-21 PI STA. = 122+49.47 $\Delta = 28^\circ 39' 37''$ (LT) $D = 16^\circ 22' 13''$ $R = 350.00'$ $T = 89.41'$ $L = 175.07'$ $E = 11.24'$ P.C. STA = 122+49.47 N: 1,993,964.06 E: 1,008,047.35 P.T. STA = 123+35.13 N: 1,993,986.37 E: 1,008,219.17	

FILE NAME = 74754-sh-h-A102.dgn

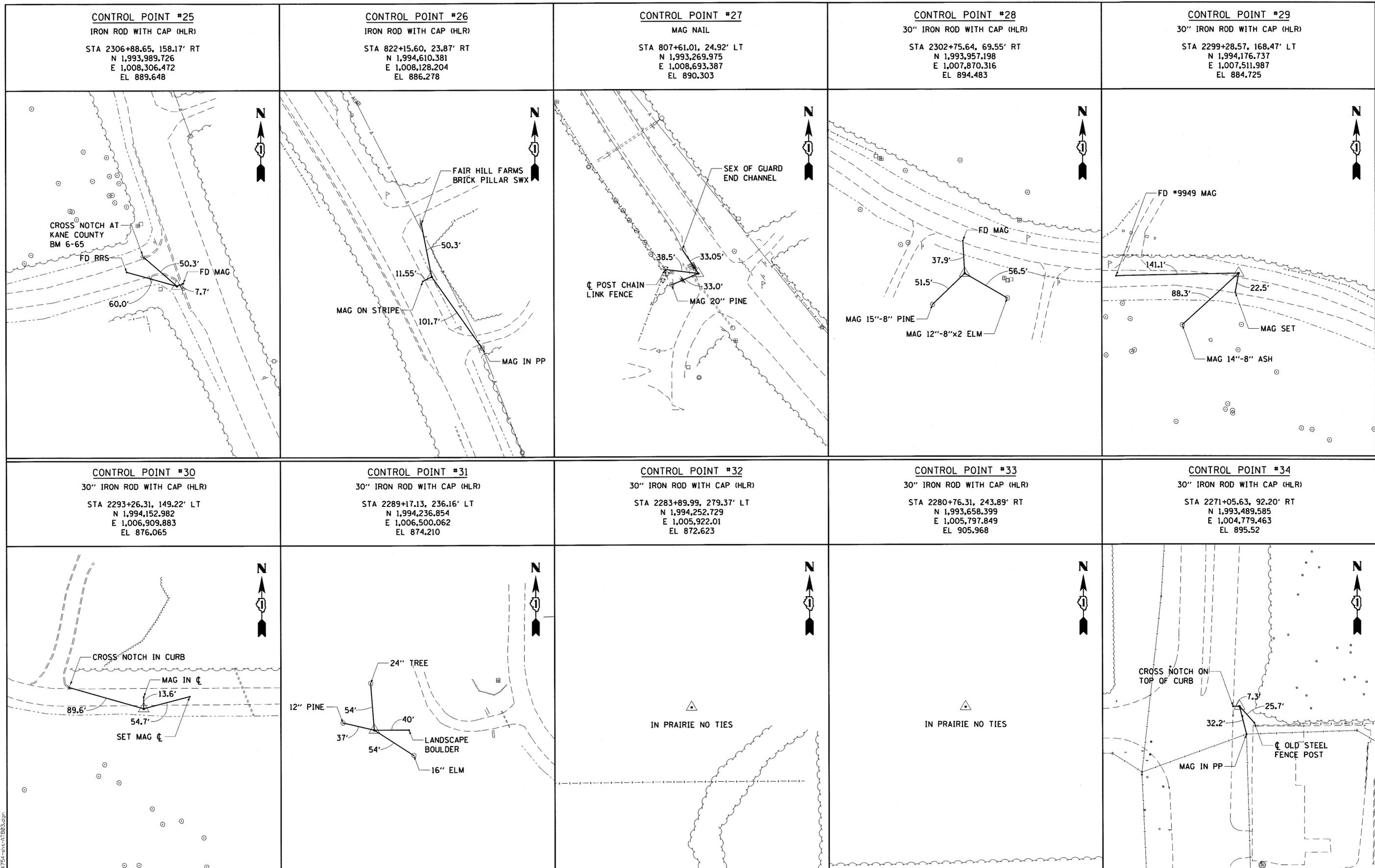

FILE NAME = 74754-sh1-ATB03.dgn

	USER NAME = rjjang	DESIGNED - N/A	REVISED -	STATE OF ILLINOIS DEPARTMENT OF TRANSPORTATION	ALIGNMENT AND TIES CONTROL POINTS			F.A.U. RTE. 2298	SECTION 13-00215-30-PV	COUNTY KANE	TOTAL SHEETS 177	SHEET NO. 26	
	PLOT SCALE = 100.0000' / 1" =	CHECKED - RMG	REVISED -		SCALE: 1" = 50'	SHEET 3 OF 3 SHEETS	STA. TO STA.	ILLINOIS FED. AID PROJECT					
	PLOT DATE = 9/1/2017	DATE - 9/5/2017	REVISED -										

TEMPORARY FENCE		
POINT	STA	O/S
01	803+38.83	49' LT
02	803+96.70	62' LT
03	804+42.51	55' LT
04	805+40.00	58' LT
05	806+15.48	80' LT
06	808+50.00	80' LT
07	809+16.53	90' LT
08	810+47.19	90' LT
09	811+38.59	72' LT
10	813+96.87	80' LT
11	807+90.00	67' RT
12	809+13.68	77' RT
13	809+97.23	77' RT
14	810+92.53	66' RT
15	812+71.49	69' RT
16	813+21.95	80' RT
17	813+49.50	80' RT
18	814+13.37	65' RT
19	815+17.89	67' RT

LEGEND

- PAVEMENT REMOVAL
- DRIVEWAY PAVEMENT REMOVAL
- PAVED SHOULDER REMOVAL
- LINEAR ITEM REMOVAL
- TEMPORARY FENCE
- TREE REMOVAL, EACH
- TREE REMOVAL, ACRES

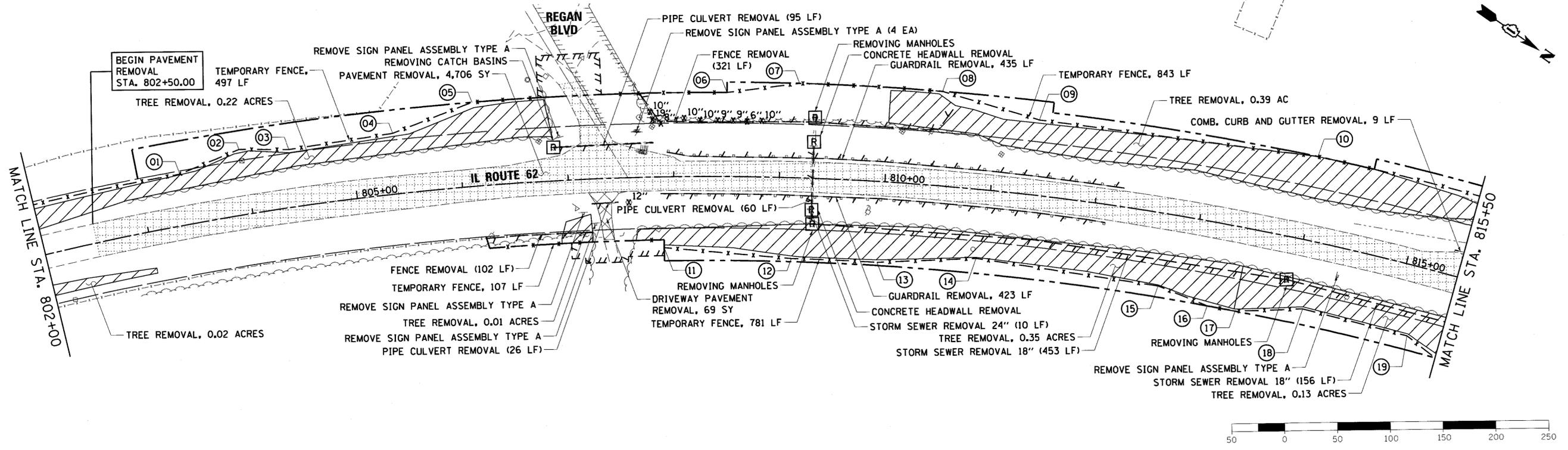
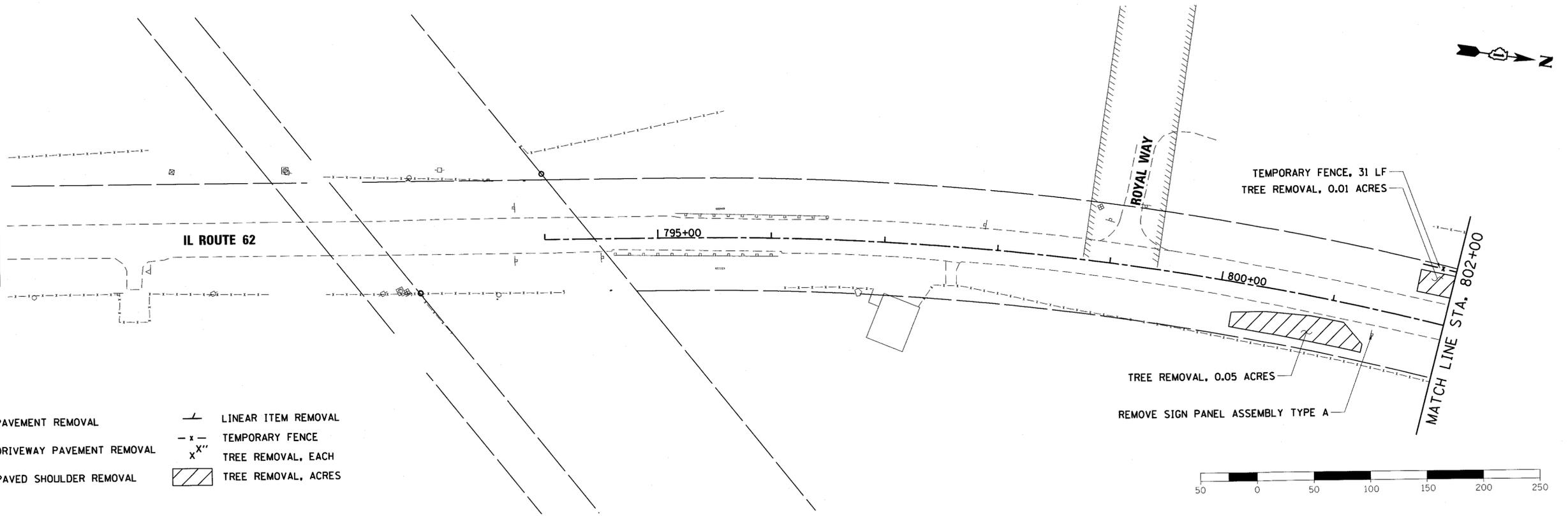

FILE NAME: 174754-abt-rm02.dgn



USER NAME = r.jiang	DESIGNED - RMG	REVISED -
PLOT SCALE = 100.0000' / in.	DRAWN - RGJ	REVISED -
PLOT DATE = 9/1/2017	CHECKED - XXX	REVISED -
	DATE - 9/5/2017	REVISED -

**STATE OF ILLINOIS
DEPARTMENT OF TRANSPORTATION**

ROADWAY REMOVAL PLAN

SCALE: 1" = 50' SHEET 2 OF 3 SHEETS STA. 794+00.00 TO STA. 815+50.00

F.A.U. RTE. 2298	SECTION 13-00215-30-PV	COUNTY KANE	TOTAL SHEETS 177	SHEET NO. 28
CONTRACT NO. 61D16				
ILLINOIS FED. AID PROJECT				

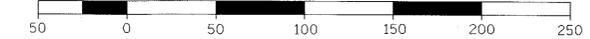
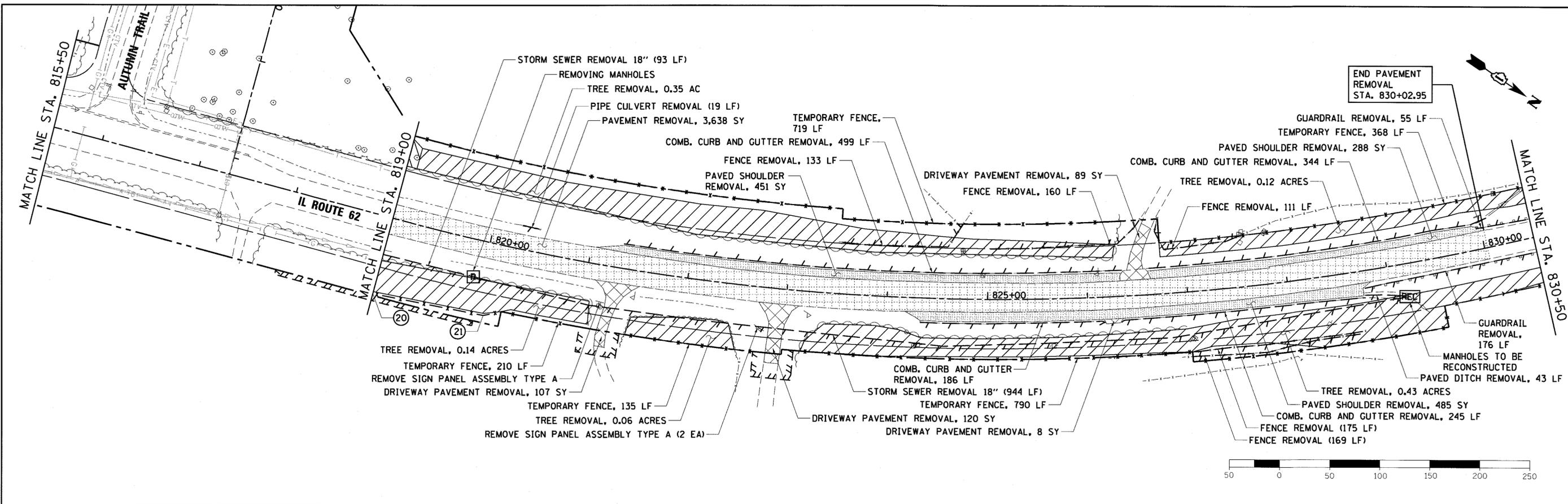

LEGEND

- PAVEMENT REMOVAL
- DRIVEWAY PAVEMENT REMOVAL
- PAVED SHOULDER REMOVAL
- LINEAR ITEM REMOVAL
- TEMPORARY FENCE
- TREE REMOVAL, EACH
- TREE REMOVAL, ACRES

TEMPORARY FENCE		
POINT	STA	O/S
20	819+00.00	78' RT
21	820+08.85	73' RT
22	830+81.07	48' RT
23	832+22.57	35' RT

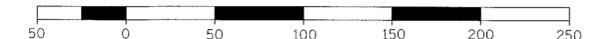
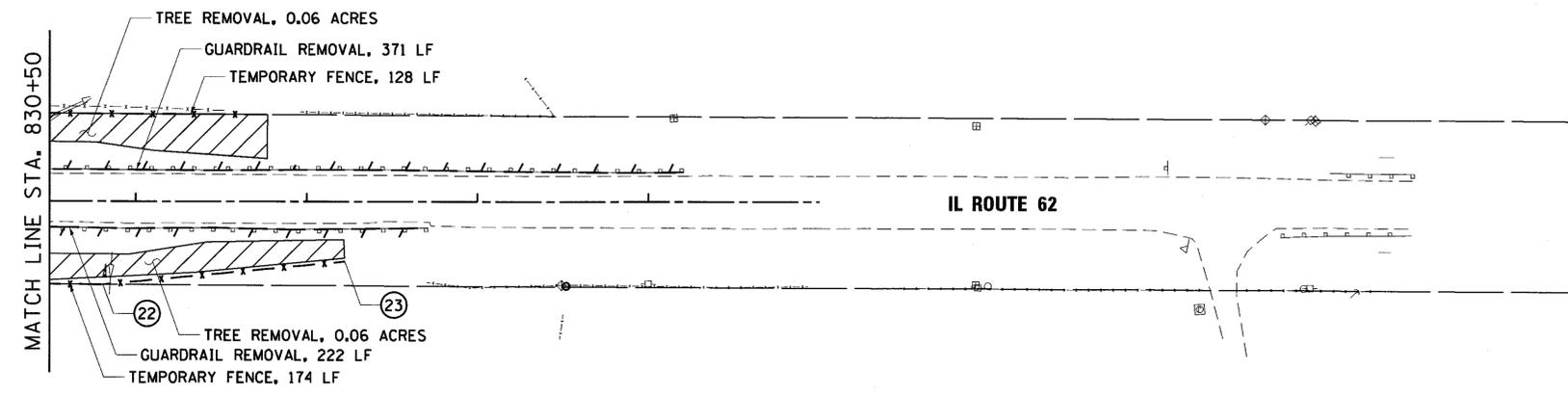

FILE NAME = 74754-sh-tr-rem03.dgn

PLAN	DESIGNED	DATE
	BY	
	NOTED	
	CHECKED	
	APPROVED	
	FILE NAME	
	NO.	

PROFILE	DESIGNED	DATE
	BY	
	NOTED	
	CHECKED	
	APPROVED	
	FILE NAME	
	NO.	

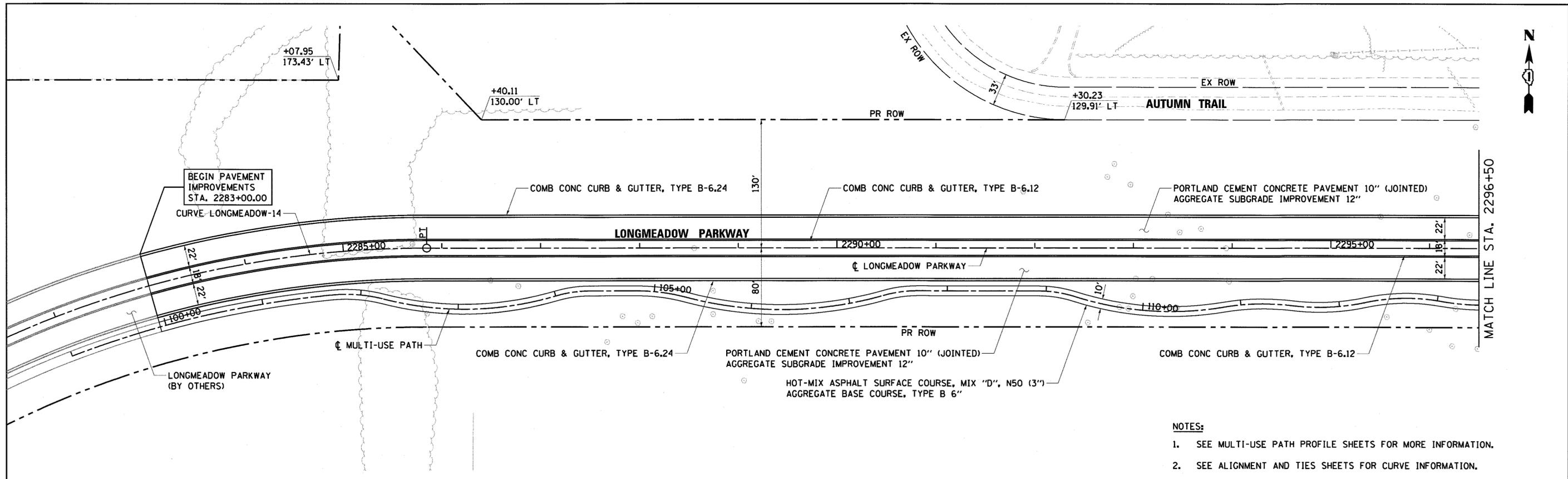

- NOTES:**
- SEE MULTI-USE PATH PROFILE SHEETS FOR MORE INFORMATION.
 - SEE ALIGNMENT AND TIES SHEETS FOR CURVE INFORMATION.

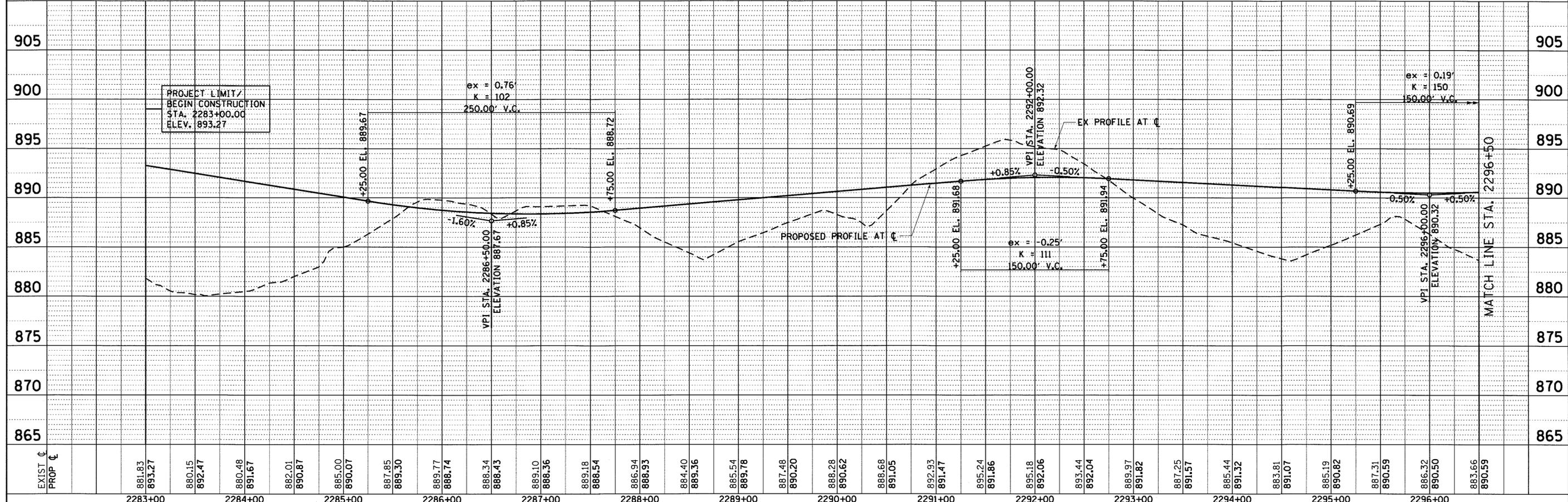

BURNS MCDONNELL	USER NAME = r.jiang	DESIGNED - MAP	REVISED -	STATE OF ILLINOIS DEPARTMENT OF TRANSPORTATION	ROADWAY PLAN AND PROFILE			F.A.U. RTE. 2298	SECTION 13-00215-30-PV	COUNTY KANE	TOTAL SHEETS 177	SHEET NO. 30	
	PLOT SCALE = 100.0000' / in.	DRAWN - RGJ	REVISED -		SCALE: 1" = 50'	SHEET 1	OF 4 SHEETS	STA. 2283+00.00	TO STA. 2296+50.00	CONTRACT NO. 61D16			
	PLOT DATE = 9/1/2017	CHECKED - RMG	REVISED -		ILLINOIS FED. AID PROJECT								
	DATE - 9/5/2017	DATE - 9/5/2017	REVISED -										

NOTES:

1. SEE MULTI-USE PATH AND PROFILE SHEET FOR MORE INFORMATION.
2. SEE ALIGNMENT AND TIES SHEETS FOR CURVE INFORMATION.
3. SEE INTERSECTION DETAIL SHEET FOR MORE INFORMATION.
4. SEE ROADWAY DETAIL SHEETS FOR DRIVEWAY AND ADA RAMP INFORMATION.

PLAN	SURVEYED	DATE
	BY	
	PLOTTED	
	CHECKED	
	DATE	
	BY	
	CHECKED	
	DATE	
	BY	
	CHECKED	
	DATE	

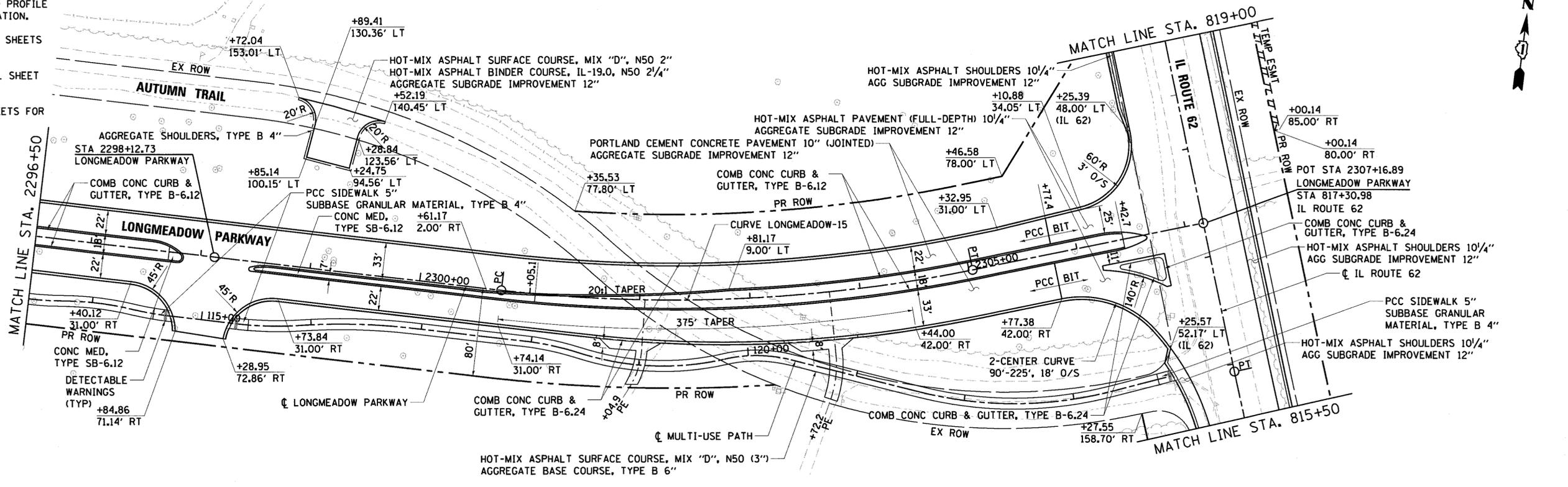

PROFILE	SURVEYED	DATE
	BY	
	PLOTTED	
	CHECKED	
	DATE	
	BY	
	CHECKED	
	DATE	

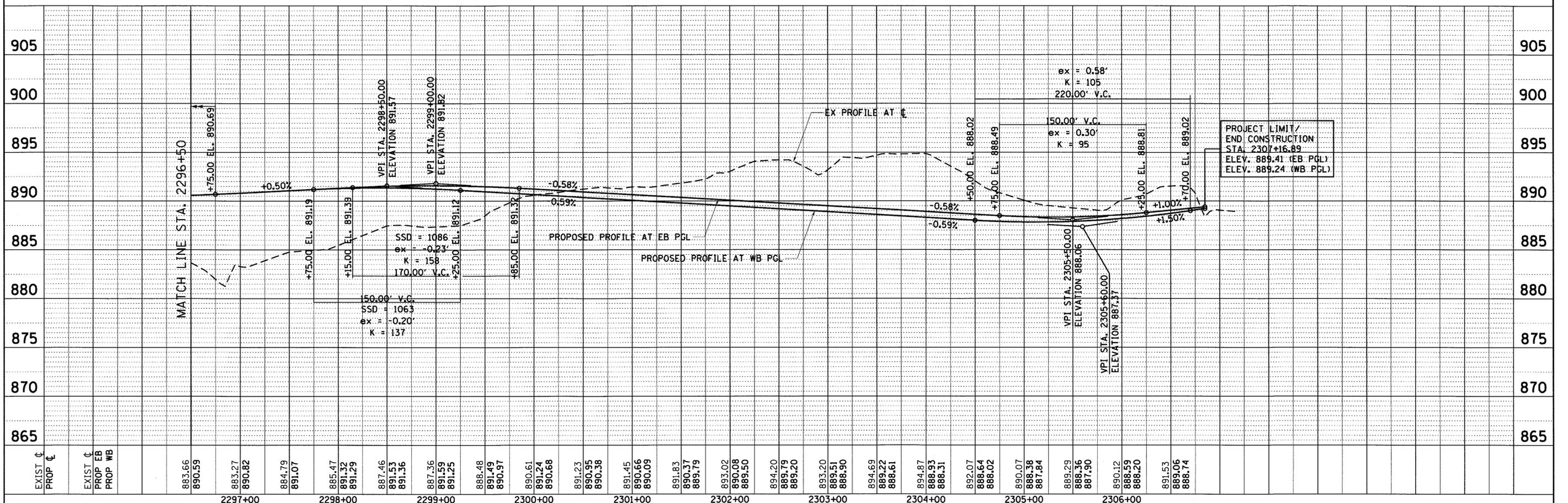

	USER NAME = r.jiang	DESIGNED - MAP	REVISED -	STATE OF ILLINOIS DEPARTMENT OF TRANSPORTATION	ROADWAY PLAN AND PROFILE	F.A.U. RTE.	SECTION	COUNTY	TOTAL SHEETS	SHEET NO.	
	PLOT SCALE = 100.0000' / 1" =	DRAWN - RGJ	REVISED -			2298	13-00215-30-PV	KANE	177	31	
	PLOT DATE = 9/1/2017	CHECKED - RMG	REVISED -			CONTRACT NO. 61D16					
		DATE - 9/5/2017	REVISED -			ILLINOIS FED. AID PROJECT					

PLAN	SURVEYED	BY	DATE
	PLOTTED		
	CHECKED		
	ALIGNED		
	ADJUSTED		
	CADD FILE NAME		
	NO.		

PROFILE	SURVEYED	BY	DATE
	PLOTTED		
	CHECKED		
	GRADES		
	STRUCTURE		
	NOTATION		
	NO.		

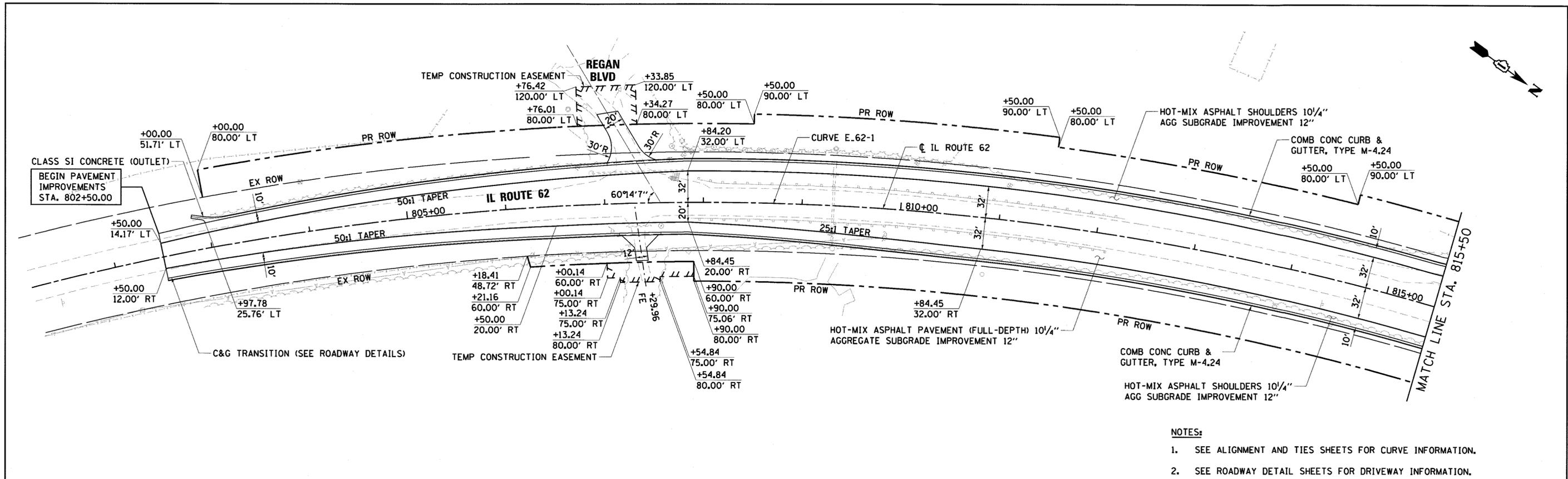

- NOTES:**
1. SEE ALIGNMENT AND TIES SHEETS FOR CURVE INFORMATION.
 2. SEE ROADWAY DETAIL SHEETS FOR DRIVEWAY INFORMATION.

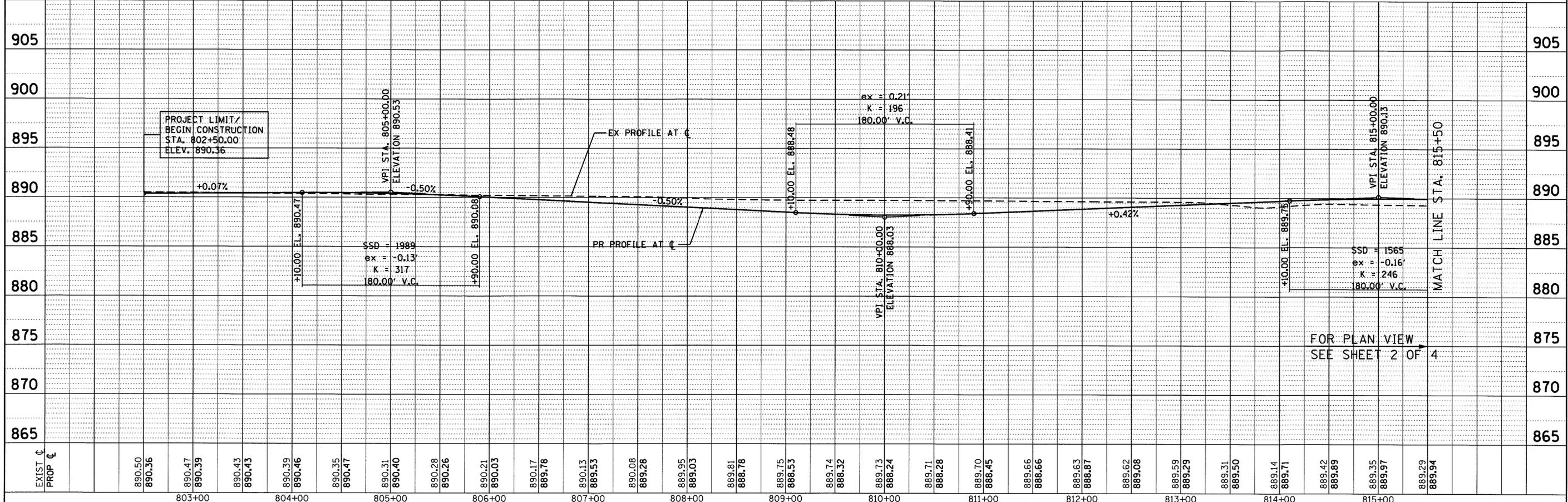

PLAN	SURVEYED	BY	DATE
	PLOTTED		
	NOTE BOOK		
	NO. _____		
	DATE _____		
	CADD FILE NAME		

PROFILE	SURVEYED	BY	DATE
	PLOTTED		
	NOTE BOOK		
	NO. _____		
	DATE _____		
	STRUCTURE NOTATION SHOWN		

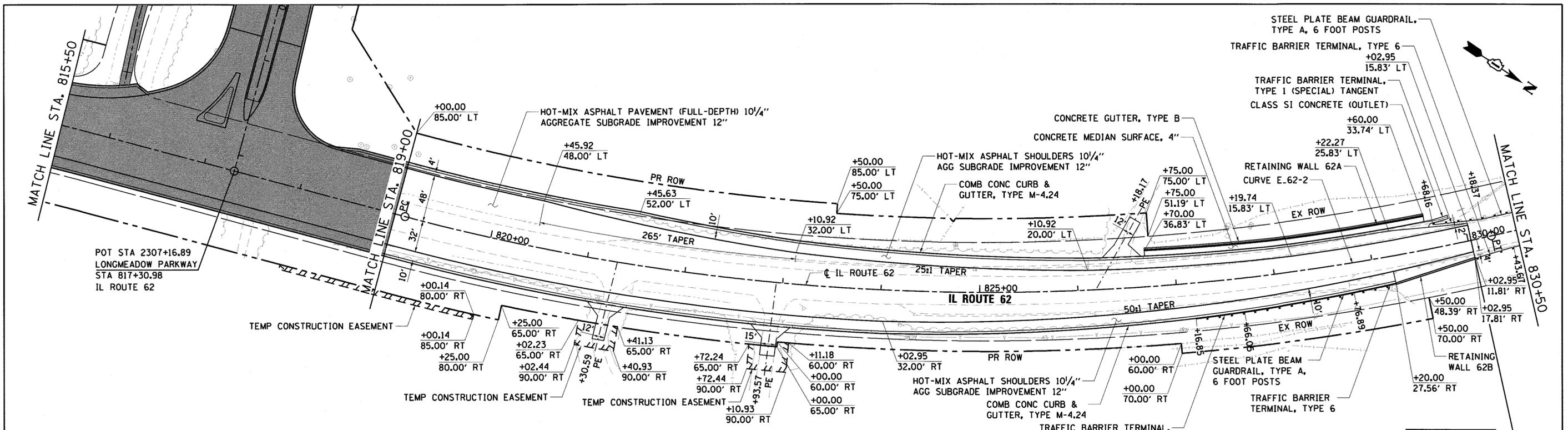

- NOTES:**
- SEE ALIGNMENT AND TIES SHEETS FOR CURVE INFORMATION.
 - REFER TO ROADWAY PLAN AND PROFILE SHEET 2 FOR THE GRAY SHADED AREA BETWEEN STA 815+50 AND 819+00.

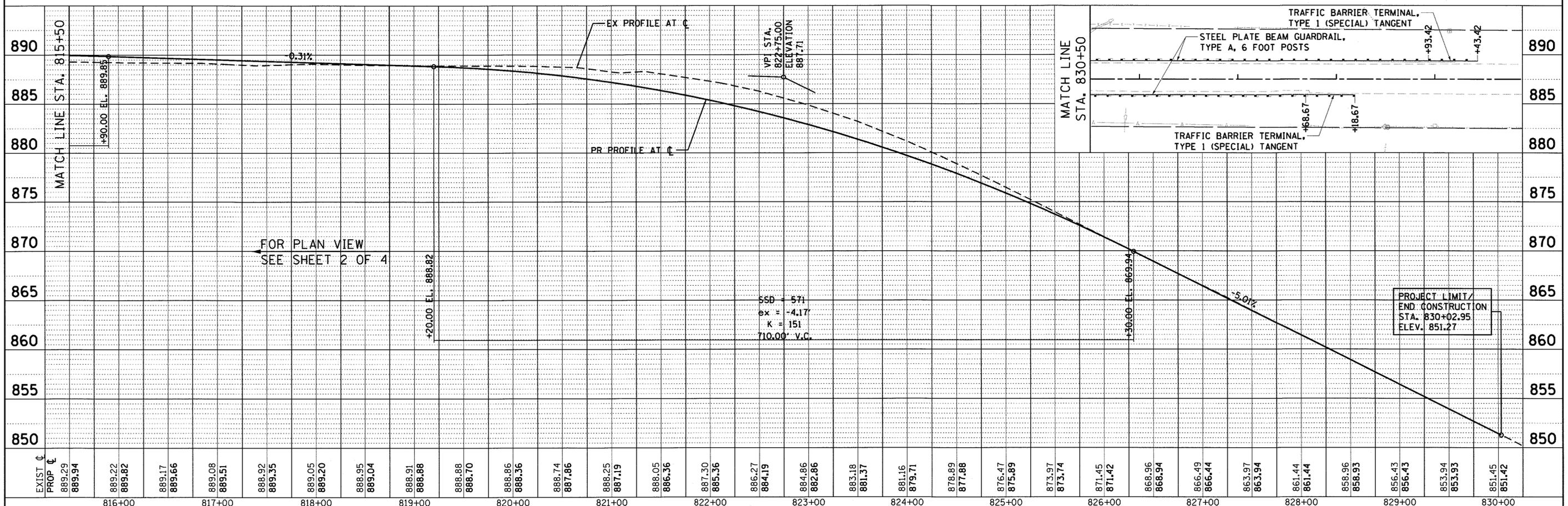

	USER NAME = r.jiang	DESIGNED - MAP	REVISED -	STATE OF ILLINOIS DEPARTMENT OF TRANSPORTATION	ROADWAY PLAN AND PROFILE	SCALE: 1" = 50' SHEET 4 OF 4 SHEETS STA. 815+50.00 TO STA. 830+02.95	F.A.U. RTE. 2298	SECTION 13-00215-30-PV	COUNTY KANE	TOTAL SHEETS 177	SHEET NO. 33
	PLLOT SCALE = 1/8" = 100.0000' / 1"	CHECKED - RMG	REVISED -				CONTRACT NO. 61D16				
	PLLOT DATE = 9/1/2017	DATE = 9/5/2017	REVISED -				ILLINOIS FED. AID PROJECT				

PLAN SURVEYED BY DATE
 FLOORED BY DATE
 ALIGNED BY DATE
 RT. OF WAY CHECKED BY DATE
 NO. CAD FILE NAME

PROFILE SURVEYED BY DATE
 FLOORED BY DATE
 ALIGNED BY DATE
 RT. OF WAY CHECKED BY DATE
 NO. STRUCTURE NOTATIONS CPWD

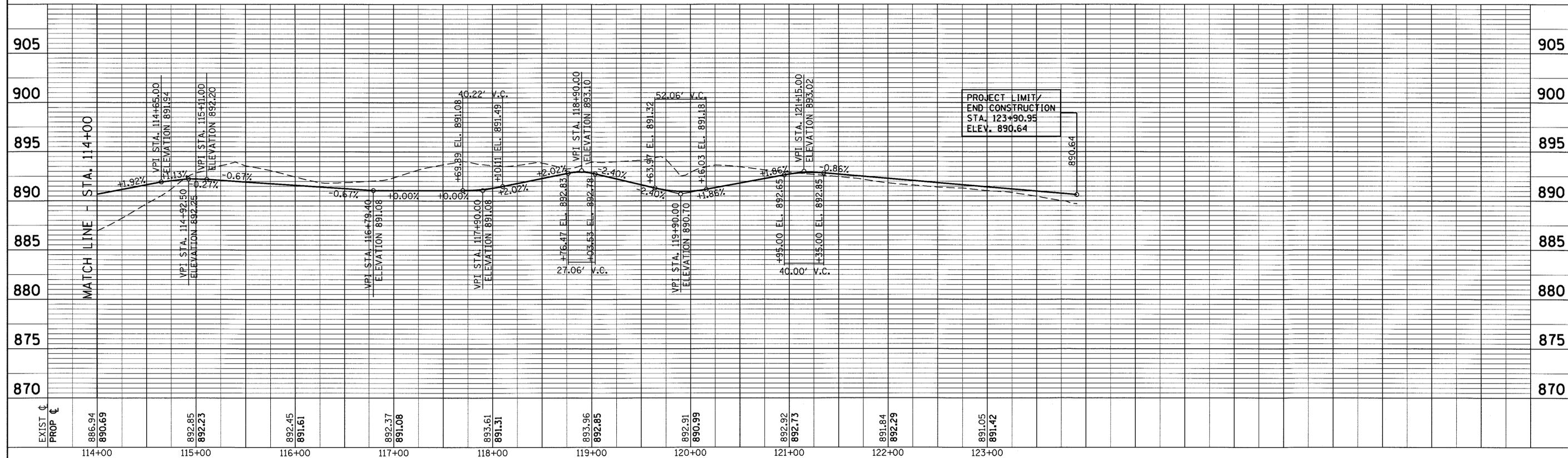
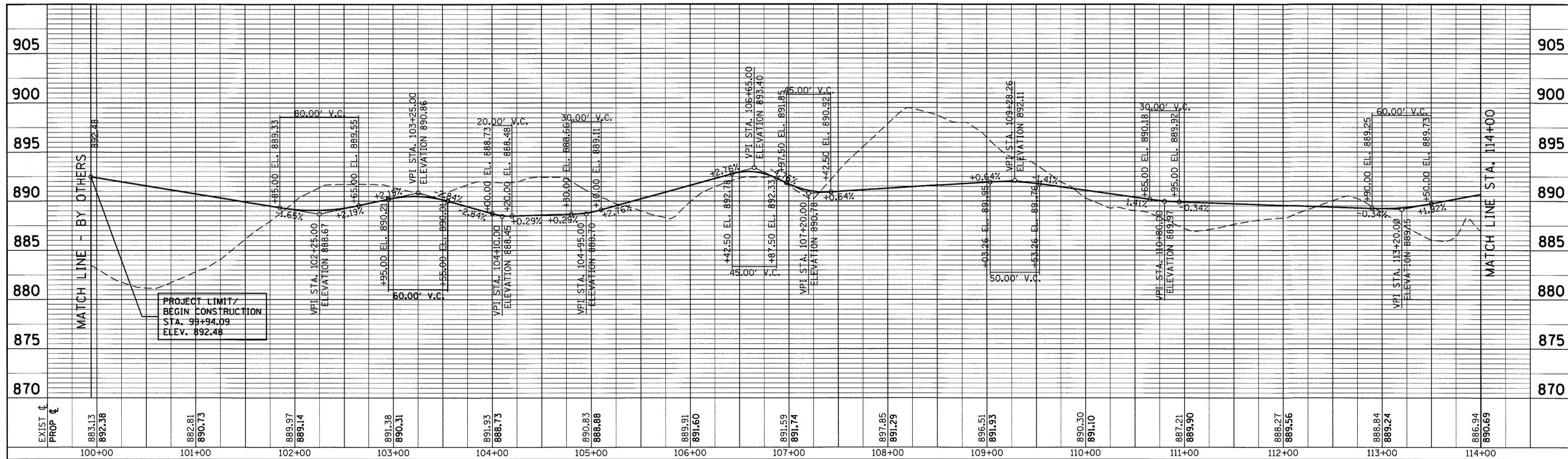

USER NAME = r.jiang
 PLOT SCALE = 100.0000' / in.
 PLOT DATE = 9/1/2017

DESIGNED - RGJ
 DRAWN - RGJ
 CHECKED - RMG
 DATE -

REVISED -
 REVISED -
 REVISED -
 REVISED -

**STATE OF ILLINOIS
 DEPARTMENT OF TRANSPORTATION**

MULTI-USE PATH PROFILE

SCALE: 1" = 50' SHEET 1 OF 1 SHEETS STA. 100+00.00 TO STA. 123+70.00

F.A.U. RTE.	SECTION	COUNTY	TOTAL SHEETS	SHEET NO.
2298	13-00215-30-PV	KANE	177	34
CONTRACT NO. 61D16				
ILLINOIS FED. AID PROJECT				

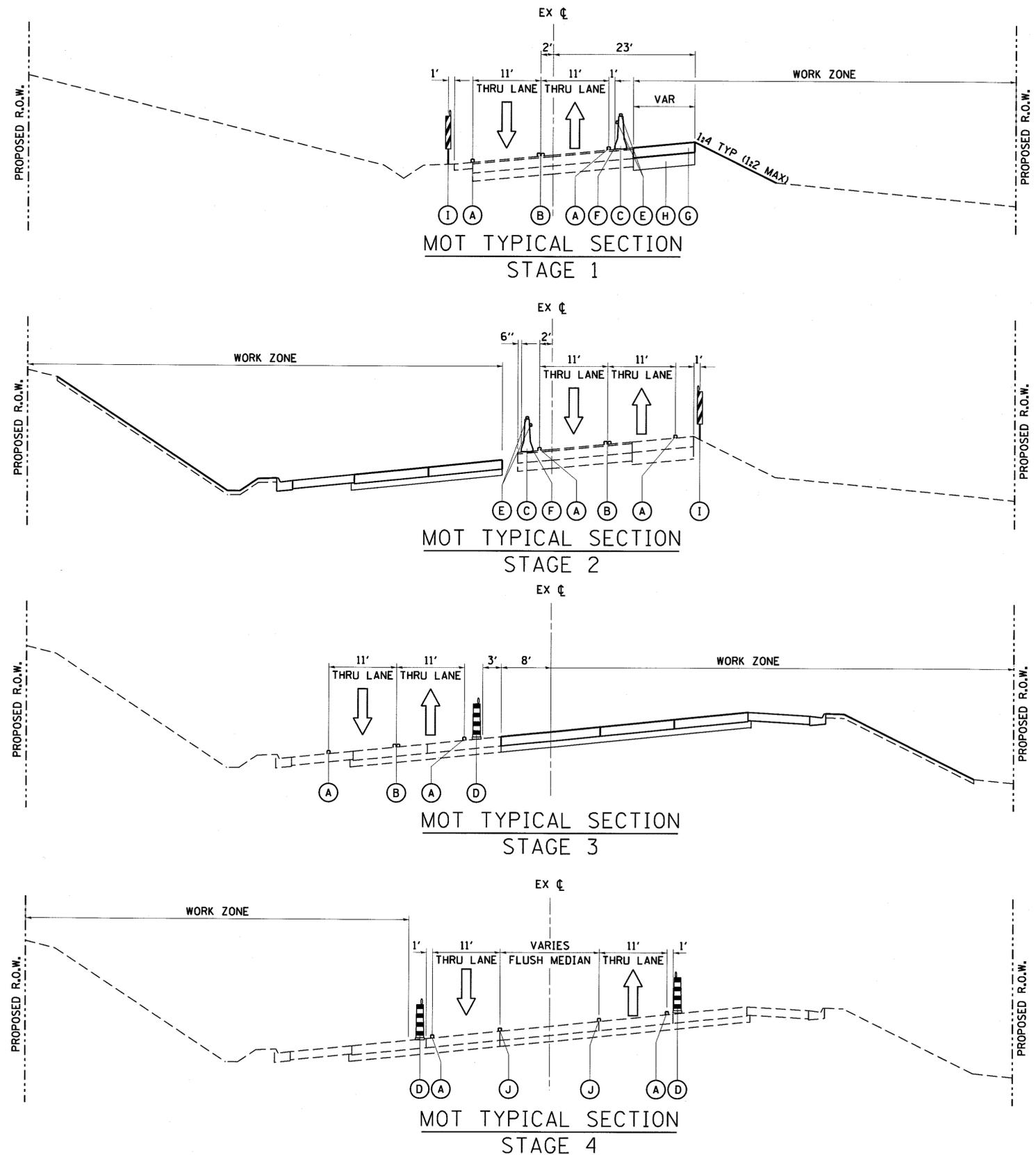

LEGEND

- (A) TEMPORARY PAVEMENT MARKING, 4" SOLID LINE (WHITE)
- (B) TEMPORARY PAVEMENT MARKING, 4" DOUBLE SOLID LINE (YELLOW)
- (C) TEMPORARY CONCRETE BARRIER WALL AND PINNING
- (D) DRUM OR TY II BARRICADE WITH STEADY BURNING BI-DIRECTIONAL LIGHT AT 50' SPACING (25' IN TAPERS AND CURVES)
- (E) BARRIER WALL REFLECTORS, TYPE C AT 25' SPACING
- (F) TEMPORARY PAVEMENT MARKING, 6" SOLID LINE (WHITE)
- (G) TEMPORARY PAVEMENT
- PCC 8"
OR
- HMA 10"
- (H) AGGREGATE SUBGRADE IMPROVEMENT 12"
- (I) DOUBLE VERTICAL PANEL WITH STEADY BURNING BI-DIRECTIONAL LIGHT AT 50' SPACING
- (J) PERMANENT PAVEMENT MARKING

NOTES

1. CONSTRUCTION ACCESS TO AUTUMN TRAIL CUL-DE-SAC SHALL BE FROM THE LONGMEADOW PARKWAY ROW ONLY.

WINTER STAGE WORK (COMPLETE BY 03/30/18)

- WORK PERFORMED
 - TREE REMOVAL
 - TOPSOIL STRIPPING AND TOPSOIL STOCKPILE ALONG LONGMEADOW PARKWAY
 - UNDERCUT AREAS ALONG LONGMEADOW PARKWAY
 - EXCAVATE DETENTION BASIN
 - CONSTRUCT EMBANKMENT ALONG LONGMEADOW PARKWAY
- TRAFFIC RESTRICTIONS
 - NONE

STAGE 1

- TRAFFIC CONFIGURATION
 - SHIFT TRAFFIC TO THE WEST SIDE OF IL-62 ON EXISTING PAVEMENT
- WORK PERFORMED
 - CONSTRUCT TEMPORARY MECHANICALLY STABILIZED EARTH RETAINING WALL AND TEMPORARY PAVEMENT
 - JACK STORM SEWERS C-16, D-9, F-2, AND F-3
 - INSTALL BYPASS STORM SEWER
 - CONSTRUCT LONGMEADOW PARKWAY WEST OF WHERE IT INTERSECTS EXISTING AUTUMN TRAIL (EXCLUDING PAVEMENT)
 - TOPSOIL STRIPPING AND TOPSOIL STOCKPILE ALONG LONGMEADOW PARKWAY
 - UNDERCUT AREAS ALONG LONGMEADOW PARKWAY
 - EXCAVATE DETENTION BASIN
 - CONSTRUCT EMBANKMENT ALONG LONGMEADOW PARKWAY
 - INSTALL SEWERS ALONG LONGMEADOW PARKWAY
- TRAFFIC RESTRICTIONS
 - NONE

STAGE 2

- TRAFFIC CONFIGURATION
 - SHIFT TRAFFIC TO THE EAST SIDE OF IL-62 ON THE TEMPORARY PAVEMENT AND EXISTING PAVEMENT
- WORK PERFORMED
 - CONSTRUCT THRU LANES, SHOULDERS, AND TEMPORARY PAVEMENT ON WEST SIDE OF IL-62
 - INSTALL TEMPORARY DRAINAGE ITEMS ON IL-62
 - CONSTRUCT RETAINING WALL 62A WITHOUT FACING (SEE DETAIL ON SHEET 1)
 - CONSTRUCT REMAINING PORTIONS OF LONGMEADOW PARKWAY (SEE STAGE 1)
 - CONSTRUCT PAVEMENT ALONG LONGMEADOW PARKWAY
- TRAFFIC RESTRICTIONS
 - ONLY LOCAL TRAFFIC MAY ENTER LONGMEADOW PARKWAY FROM IL-62

STAGE 3

- TRAFFIC CONFIGURATION
 - SHIFT TRAFFIC ONTO THE SHOULDER AND PAVEMENT CONSTRUCTED IN STAGE 2
- WORK PERFORMED
 - REMOVE TEMPORARY PAVEMENT CONSTRUCTED IN STAGE 1
 - CONSTRUCT REMAINING PAVEMENT AND RETAINING WALL 62B
- TRAFFIC RESTRICTIONS
 - ONLY LOCAL TRAFFIC MAY ENTER LONGMEADOW PARKWAY FROM IL-62

STAGE 4

- TRAFFIC CONFIGURATION
 - TRAFFIC TO BE IN INSIDE LANE IN BOTH DIRECTIONS OF IL-62
 - OUTSIDE LANE WILL REMAIN CLOSED IN THIS STAGE
- WORK PERFORMED
 - REMOVE TEMPORARY PAVEMENT CONSTRUCTED IN STAGE 2
 - CONSTRUCT REMAINING SHOULDER AND CURB & GUTTER
 - FINISH CONSTRUCTION OF RETAINING WALL 62A
- TRAFFIC RESTRICTIONS
 - ONLY LOCAL TRAFFIC MAY ENTER LONGMEADOW PARKWAY FROM IL-62

FILE NAME = 2/17/18-act-mot-typical.dgn

BURNS MCDONNELL	USER NAME = rjiang	DESIGNED - RGJ	REVISED -	STATE OF ILLINOIS DEPARTMENT OF TRANSPORTATION	MAINTENANCE OF TRAFFIC TYPICAL SECTIONS		F.A.U. RTE. 2298	SECTION 13-00215-30-PV	COUNTY KANE	TOTAL SHEETS 177	SHEET NO. 35
	PLOT SCALE = 20.0000' / in.	CHECKED - RMG	REVISED -				CONTRACT NO. 61D16				
	PLOT DATE = 9/1/2017	DATE - 9/5/2017	REVISED -				ILLINOIS FED. AID PROJECT				

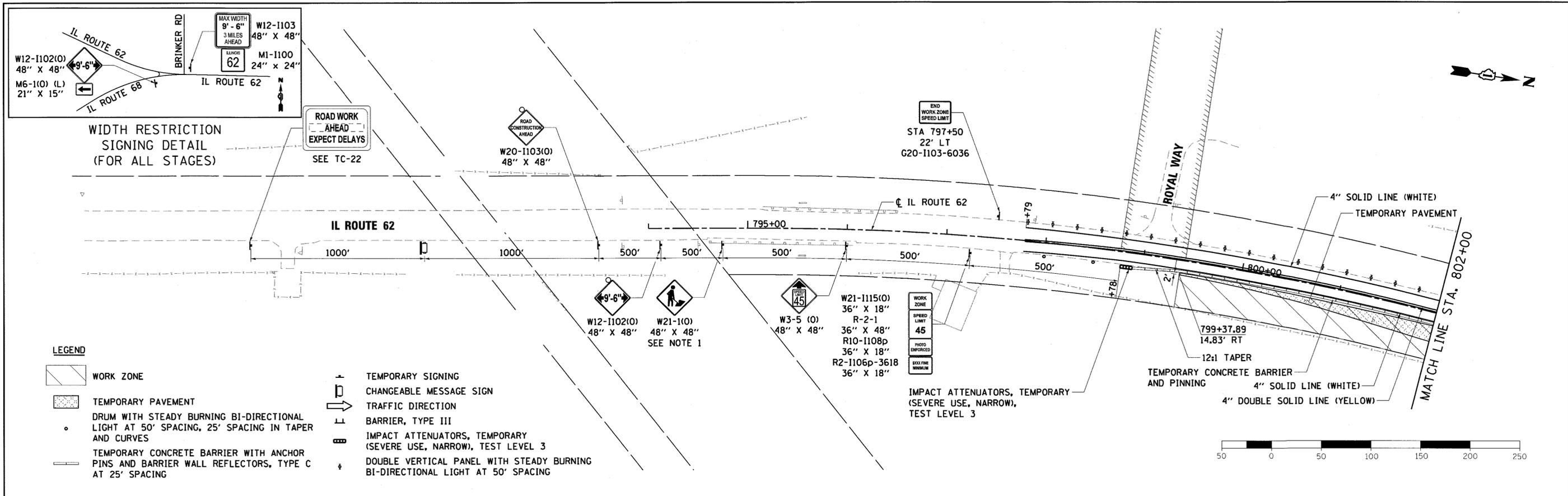

- NOTES**
- W21-110(O) SIGN SHALL BE TAKEN DOWN WHEN WORKERS ARE NOT PRESENT.
 - SEE WIDTH RESTRICTION SIGNING DETAIL FOR SIGNING AT THE INTERSECTION OF IL ROUTE 62, IL ROUTE 68, AND BRINKER RD. SIGNAGE SHALL BE MAINTAINED THROUGH ALL STAGES.

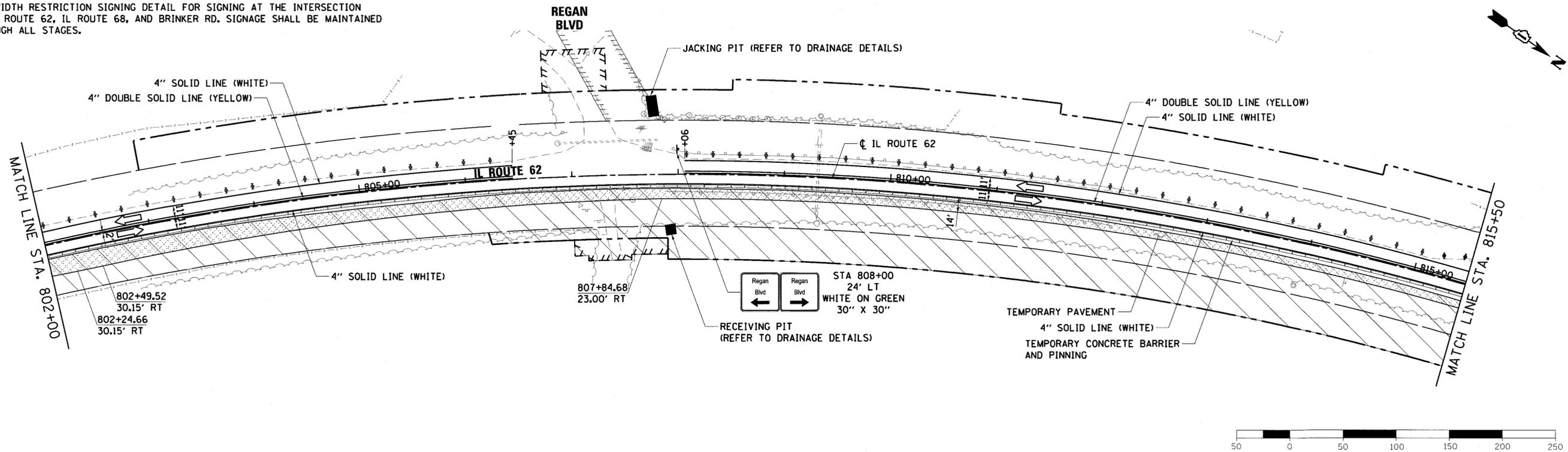

FILE NAME = 74754-shr-93101.dgn

	USER NAME = rj.ang	DESIGNED - RGJ	REVISED -	STATE OF ILLINOIS DEPARTMENT OF TRANSPORTATION	MAINTENANCE OF TRAFFIC STAGE 1			F.A.U. RTE. 2298	SECTION 13-00215-30-PV	COUNTY KANE	TOTAL SHEETS 177	SHEET NO. 36
	PLOT SCALE = 100.0000' / 1"	CHECKED - RMG	REVISED -		SCALE: 1" = 50'	SHEET 1 OF 2 SHEETS	STA. TO STA.	CONTRACT NO. 61D16				
	PLOT DATE = 9/1/2017	DATE - 9/5/2017	REVISED -		ILLINOIS FED. AID PROJECT							

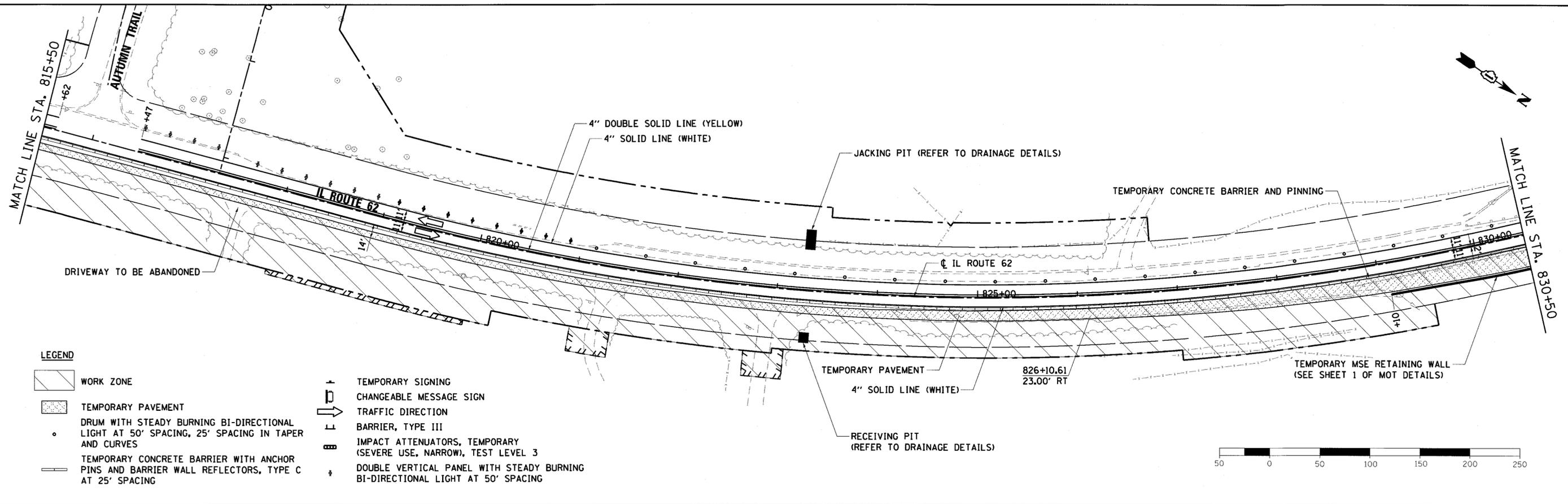

- NOTES**
- W21-1(0) SIGN SHALL BE TAKEN DOWN WHEN WORKERS ARE NOT PRESENT.
 - SEE WIDTH RESTRICTION SIGNING DETAIL FOR SIGNING AT THE INTERSECTION OF IL ROUTE 62 AND IL ROUTE 25. SIGNAGE SHALL BE MAINTAINED THROUGH ALL STAGES.

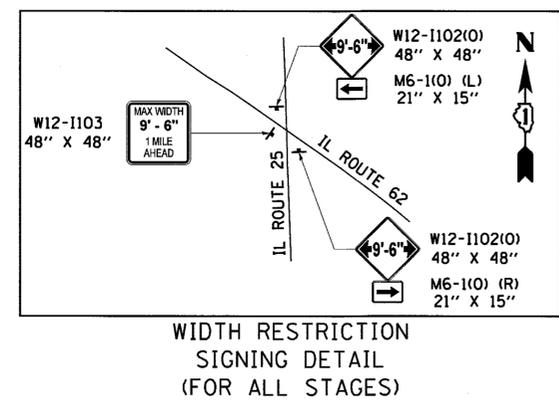
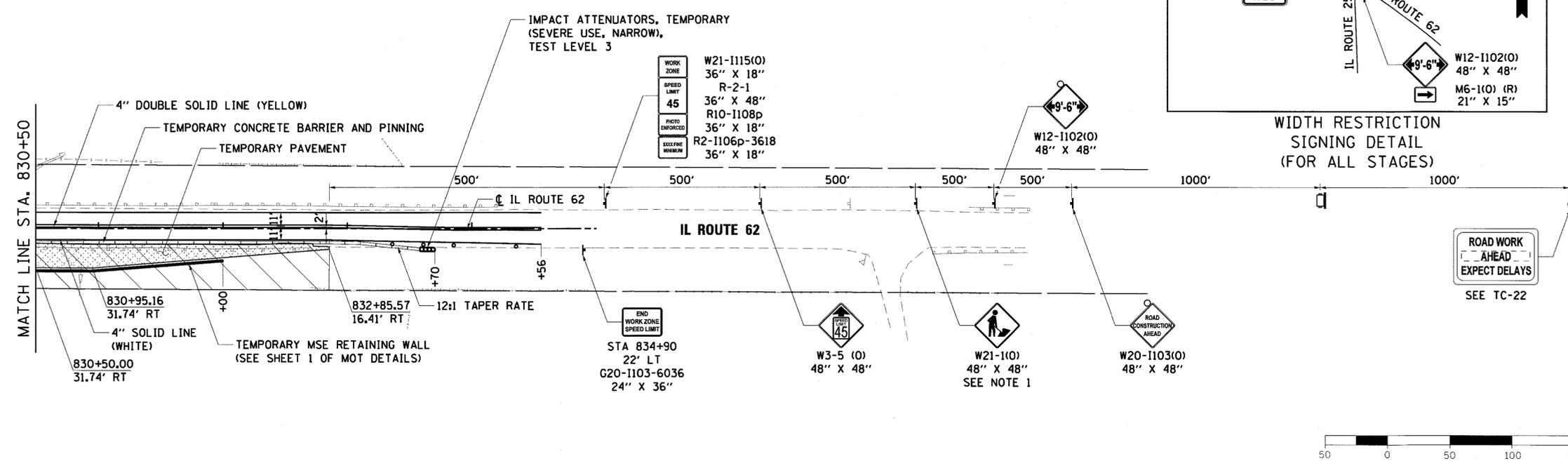

FILE NAME = 74754-ahh-stg102.dgn

	USER NAME = rjjang	DESIGNED - RGJ	REVISED -	STATE OF ILLINOIS DEPARTMENT OF TRANSPORTATION	MAINTENANCE OF TRAFFIC STAGE 1			F.A.I. RTE. 2298	SECTION 13-00215-30-PV	COUNTY KANE	TOTAL SHEETS 177	SHEET NO. 37
	PLOT SCALE = 100.0000' / in.	CHECKED - RMG	REVISED -		SCALE: 1" = 50'	SHEET 2 OF 2 SHEETS	STA. TO STA.	CONTRACT NO. 61D16				
	PLOT DATE = 9/1/2017	DATE - 9/5/2017	REVISED -					ILLINOIS FED. AID PROJECT				

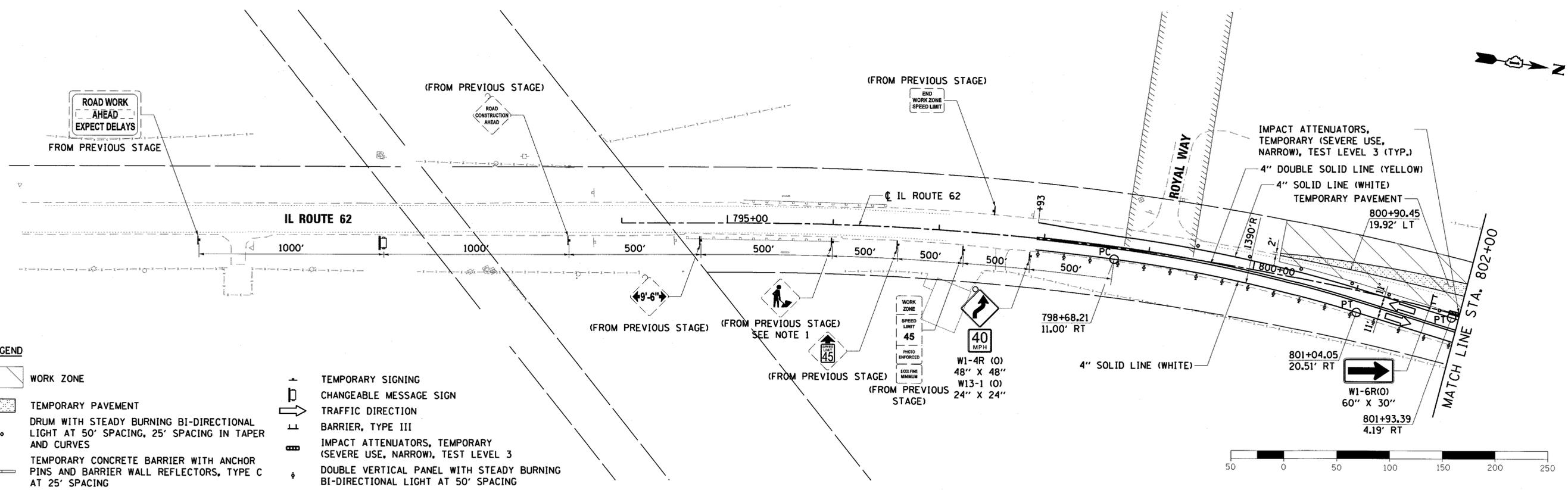

- LEGEND**
- WORK ZONE
 - TEMPORARY PAVEMENT
 - DRUM WITH STEADY BURNING BI-DIRECTIONAL LIGHT AT 50' SPACING, 25' SPACING IN TAPER AND CURVES
 - TEMPORARY CONCRETE BARRIER WITH ANCHOR PINS AND BARRIER WALL REFLECTORS, TYPE C AT 25' SPACING
 - TEMPORARY SIGNING
 - CHANGEABLE MESSAGE SIGN
 - TRAFFIC DIRECTION
 - BARRIER, TYPE III
 - IMPACT ATTENUATORS, TEMPORARY (SEVERE USE, NARROW), TEST LEVEL 3
 - DOUBLE VERTICAL PANEL WITH STEADY BURNING BI-DIRECTIONAL LIGHT AT 50' SPACING

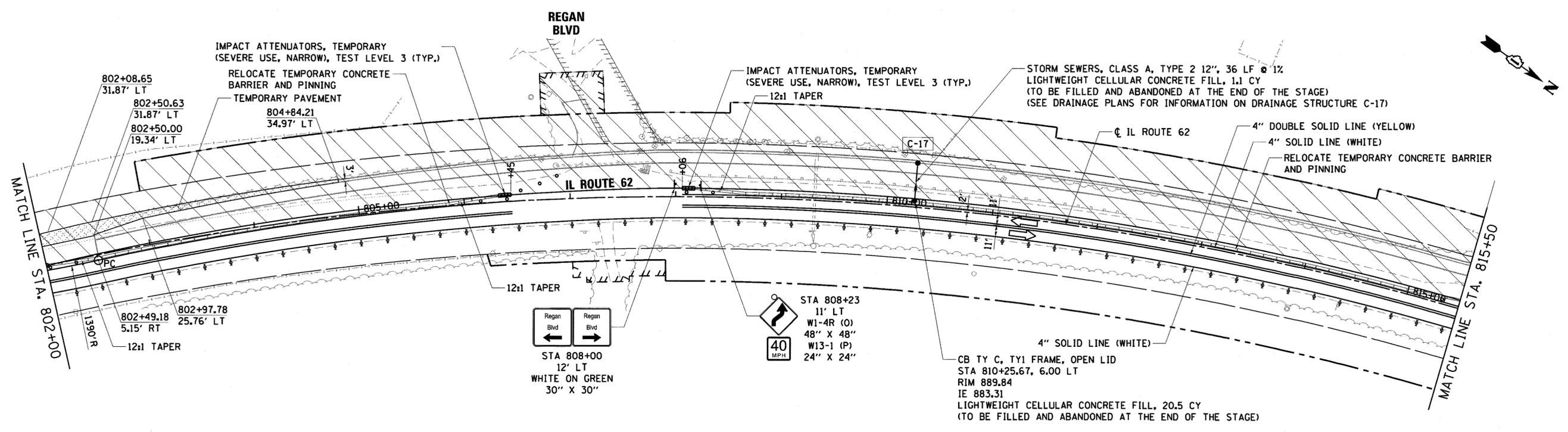

- NOTES**
1. W21-10(S) SIGN SHALL BE TAKEN DOWN WHEN WORKERS ARE NOT PRESENT.
 2. SIGNS AT THE INTERSECTION OF IL ROUTE 62 AND IL ROUTE 68 AND THE INTERSECTION OF IL ROUTE 62 AND IL ROUTE 25 SHALL REMAIN IN PLACE FOR THIS STAGE.

FILE NAME = 74754-1111-1111-1111.dgn

BURNS MCDONNELL	USER NAME = rjlang	DESIGNED - RGJ	REVISED -	STATE OF ILLINOIS DEPARTMENT OF TRANSPORTATION	MAINTENANCE OF TRAFFIC STAGE 2	F.A.U. RTE. = 2298	SECTION = 13-00215-30-PV	COUNTY = KANE	TOTAL SHEETS = 177	SHEET NO. = 38
	PLOT SCALE = 100.0000' / 1" =	CHECKED - RMG	REVISED -			SCALE: 1" = 50'	SHEET 1 OF 2 SHEETS	STA. TO STA.	CONTRACT NO. 61D16 ILLINOIS FED. AID PROJECT	
	PLOT DATE = 9/1/2017	DATE = 9/5/2017	REVISED -							

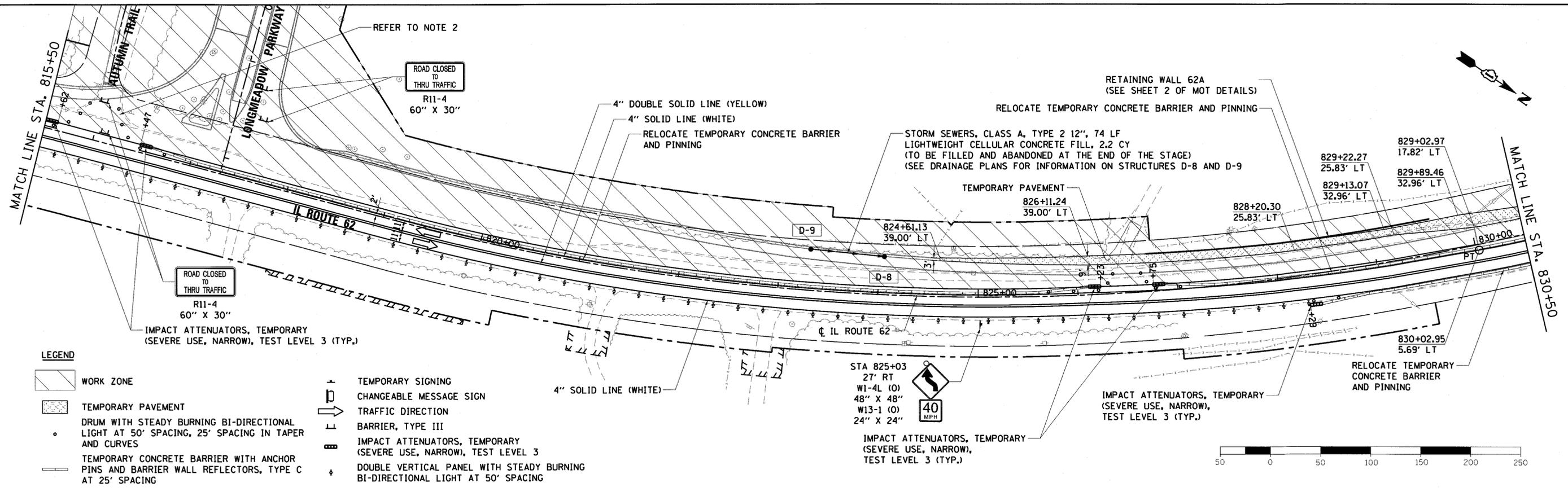

LEGEND

- WORK ZONE
- TEMPORARY PAVEMENT
- DRUM WITH STEADY BURNING BI-DIRECTIONAL LIGHT AT 50' SPACING, 25' SPACING IN TAPER AND CURVES
- TEMPORARY CONCRETE BARRIER WITH ANCHOR PINS AND BARRIER WALL REFLECTORS, TYPE C AT 25' SPACING
- TEMPORARY SIGNING CHANGEABLE MESSAGE SIGN
- TRAFFIC DIRECTION
- BARRIER, TYPE III
- IMPACT ATTENUATORS, TEMPORARY (SEVERE USE, NARROW), TEST LEVEL 3
- DOUBLE VERTICAL PANEL WITH STEADY BURNING BI-DIRECTIONAL LIGHT AT 50' SPACING

NOTES

1. W21-1(0) SIGN SHALL BE TAKEN DOWN WHEN WORKERS ARE NOT PRESENT.
2. MAINTAIN ACCESS TO AUTUMN TRAIL UNTIL THE HOMEOWNER AT THE SOUTHWEST CORNER OF THE INTERSECTION IS ABLE TO ACCESS THEIR PROPERTY THROUGH LONGMEADOW PARKWAY. WHEN ACCESS TO AUTUMN TRAIL IS REMOVED, RELOCATE THE GAP IN THE TEMPORARY CONCRETE BARRIER TO THE STATIONING SHOWN IN STAGE 3 FOR ACCESS TO LONGMEADOW PARKWAY. REFER TO INTERIM STAGE FOR LONGMEADOW DRIVEWAY ACCESS DETAIL SHEET FOR LONGMEADOW PARKWAY STAGING.
3. SIGNS AT THE INTERSECTION OF IL ROUTE 62 AND IL ROUTE 68 AND THE INTERSECTION OF IL ROUTE 62 AND IL ROUTE 25 SHALL REMAIN IN PLACE FOR THIS STAGE.

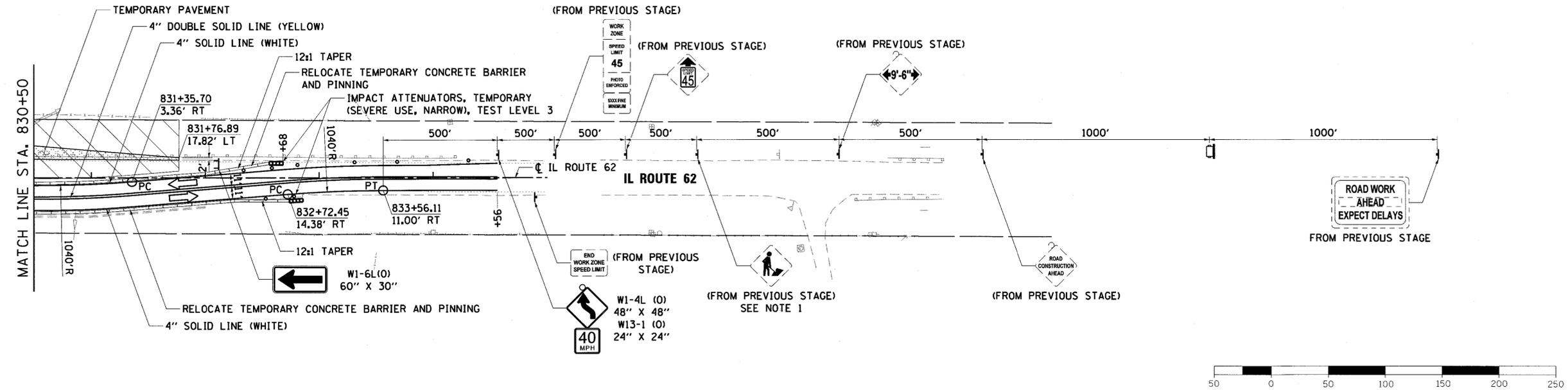

FILE NAME = 74754-ahh-100202.dgn

BURNS MCDONNELL	USER NAME = rjiang	DESIGNED - RGJ	REVISED -	STATE OF ILLINOIS DEPARTMENT OF TRANSPORTATION	MAINTENANCE OF TRAFFIC STAGE 2			F.A.U. RTE. 2298	SECTION 13-00215-30-PV	COUNTY KANE	TOTAL SHEETS 177	SHEET NO. 39
	PLOT SCALE = 1/8" = 100'-00" / 1" =	CHECKED - RMG	REVISED -		SCALE: 1" = 50'	SHEET 2 OF 2 SHEETS	STA.	TO STA.	CONTRACT NO. 61D16			
	PLOT DATE = 9/1/2017	DATE - 9/5/2017	REVISED -		ILLINOIS FED. AID PROJECT							

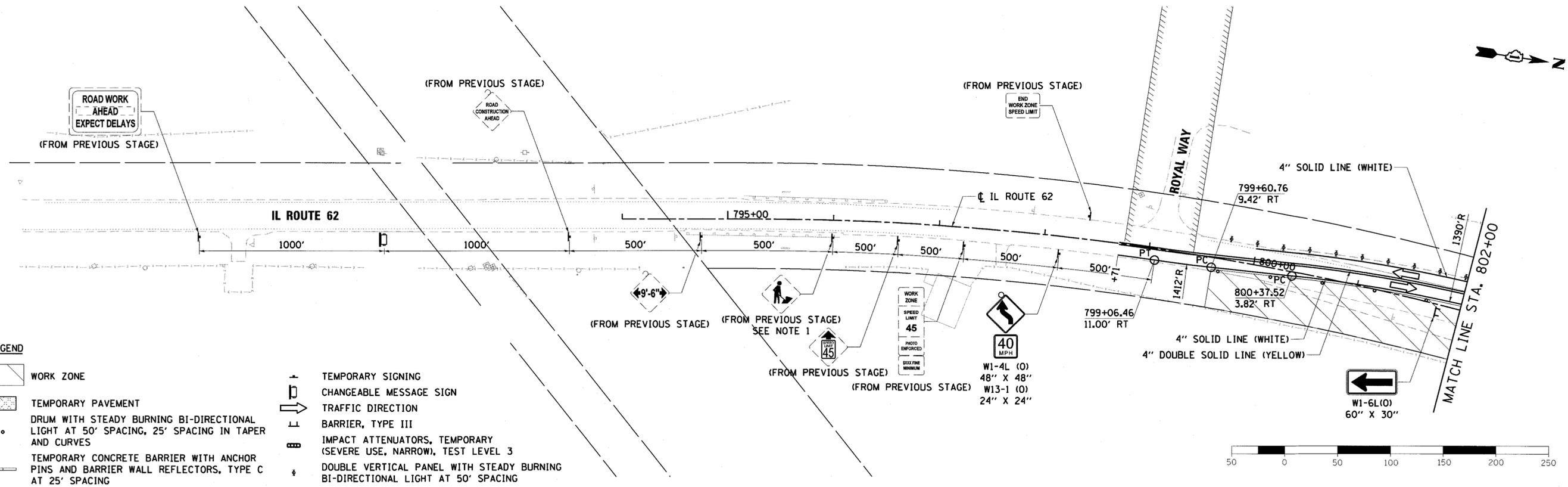

LEGEND

- WORK ZONE
- TEMPORARY PAVEMENT
- DRUM WITH STEADY BURNING BI-DIRECTIONAL LIGHT AT 50' SPACING, 25' SPACING IN TAPER AND CURVES
- TEMPORARY CONCRETE BARRIER WITH ANCHOR PINS AND BARRIER WALL REFLECTORS, TYPE C AT 25' SPACING
- TEMPORARY SIGNING
- CHANGEABLE MESSAGE SIGN
- TRAFFIC DIRECTION
- BARRIER, TYPE III
- IMPACT ATTENUATORS, TEMPORARY (SEVERE USE, NARROW), TEST LEVEL 3
- DOUBLE VERTICAL PANEL WITH STEADY BURNING BI-DIRECTIONAL LIGHT AT 50' SPACING

NOTES

1. W21-1(O) SIGN SHALL BE TAKEN DOWN WHEN WORKERS ARE NOT PRESENT.
2. SIGNS AT THE INTERSECTION OF IL ROUTE 62 AND IL ROUTE 68 AND THE INTERSECTION OF IL ROUTE 62 AND IL ROUTE 25 SHALL REMAIN IN PLACE FOR THIS STAGE.

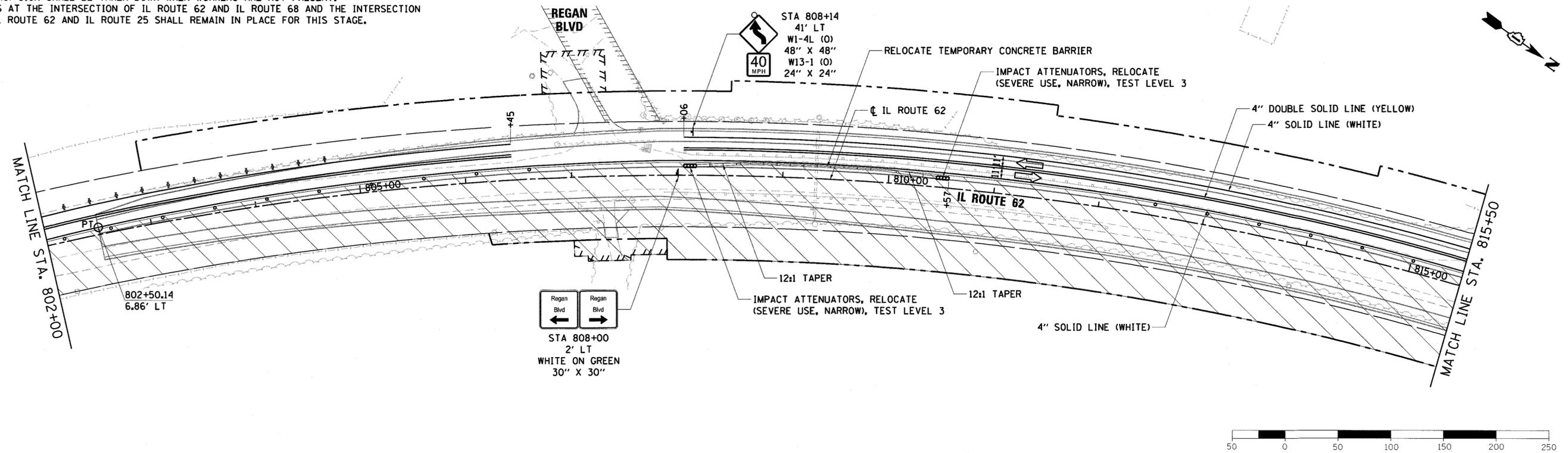

FILE NAME = 74754-sh1-10301.dgn

BURNS MCDONNELL	USER NAME = rjiang	DESIGNED - RGJ	REVISED -	STATE OF ILLINOIS DEPARTMENT OF TRANSPORTATION	MAINTENANCE OF TRAFFIC STAGE 3			F.A.J. RTE. 2298	SECTION 13-00215-30-PV	COUNTY KANE	TOTAL SHEETS 177	SHEET NO. 40
	PLOT SCALE = 100.0000' / in.	CHECKED - RMG	REVISED -		SCALE: 1" = 50'	SHEET 1 OF 2 SHEETS	STA. TO STA.	CONTRACT NO. 61D16				
	PLOT DATE = 9/1/2017	DATE - 9/5/2017	REVISED -		ILLINOIS FED. AID PROJECT							

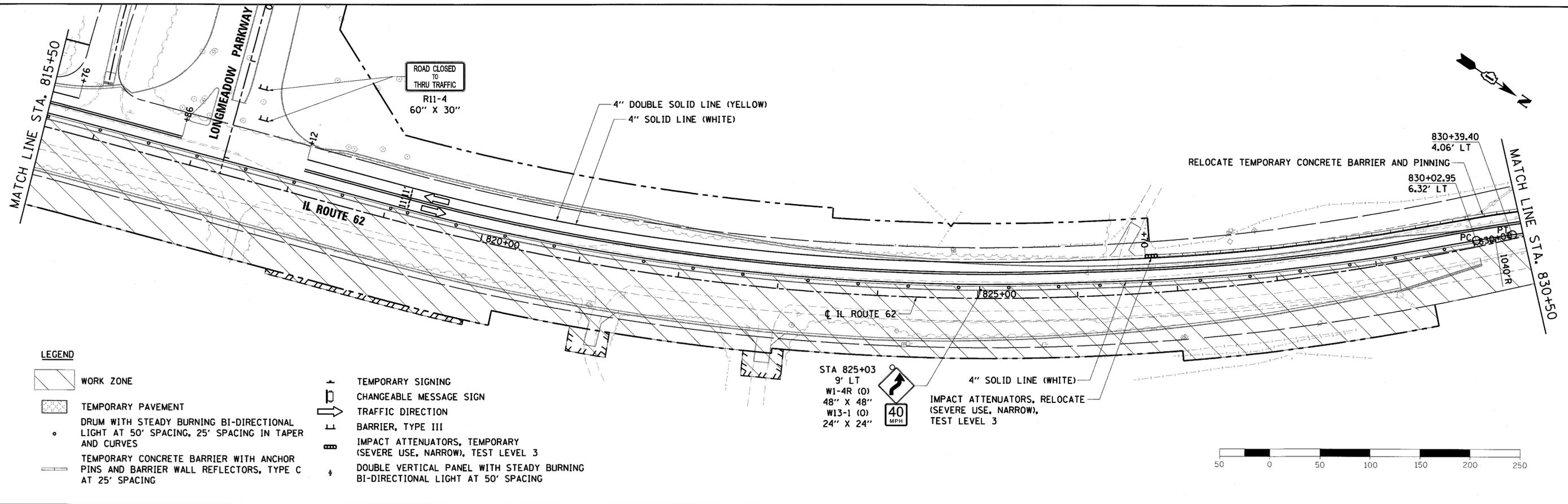

- LEGEND**
- WORK ZONE
 - TEMPORARY PAVEMENT
 - DRUM WITH STEADY BURNING BI-DIRECTIONAL LIGHT AT 50' SPACING, 25' SPACING IN TAPER AND CURVES
 - TEMPORARY CONCRETE BARRIER WITH ANCHOR PINS AND BARRIER WALL REFLECTORS, TYPE C AT 25' SPACING
 - TEMPORARY SIGNING
 - CHANGEABLE MESSAGE SIGN
 - TRAFFIC DIRECTION
 - BARRIER, TYPE III
 - IMPACT ATTENUATORS, TEMPORARY (SEVERE USE, NARROW), TEST LEVEL 3
 - DOUBLE VERTICAL PANEL WITH STEADY BURNING BI-DIRECTIONAL LIGHT AT 50' SPACING

- NOTES**
- W21-1(O) SIGN SHALL BE TAKEN DOWN WHEN WORKERS ARE NOT PRESENT.
 - SIGNS AT THE INTERSECTION OF IL ROUTE 62 AND IL ROUTE 68 AND THE INTERSECTION OF IL ROUTE 62 AND IL ROUTE 25 SHALL REMAIN IN PLACE FOR THIS STAGE.
 - REFER TO INTERIM STAGE FOR LONGMEADOW DRIVEWAY ACCESS DETAIL SHEET FOR LONGMEADOW PARKWAY STAGING.

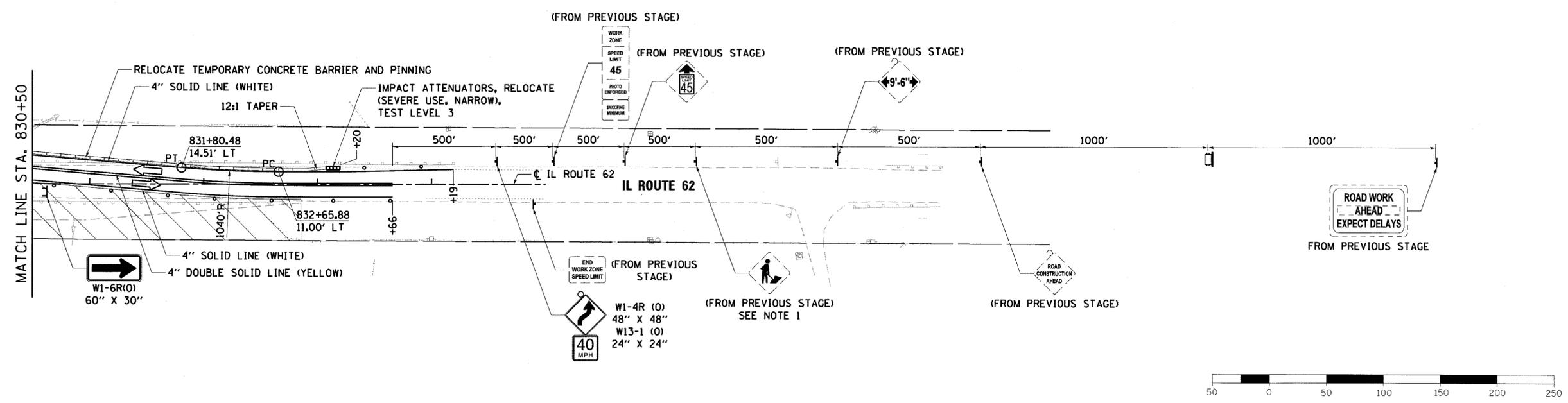

FILE NAME = 74754-ah-13-0215-30-16.dgn

BURNS MCDONNELL	USER NAME = rjwang	DESIGNED - RGJ	REVISED -	STATE OF ILLINOIS DEPARTMENT OF TRANSPORTATION	MAINTENANCE OF TRAFFIC STAGE 3	F.A.U. RTE. 2298	SECTION 13-00215-30-PV	COUNTY KANE	TOTAL SHEETS 177	SHEET NO. 41
	PLOT SCALE = 1/8" = 100'	CHECKED - RMG	REVISED -			SCALE: 1" = 50'	SHEET 2 OF 2 SHEETS	STA. TO STA.	CONTRACT NO. 61D16 ILLINOIS FED. AID PROJECT	
	PLOT DATE = 9/1/2017	DATE = 9/5/2017	REVISED -							

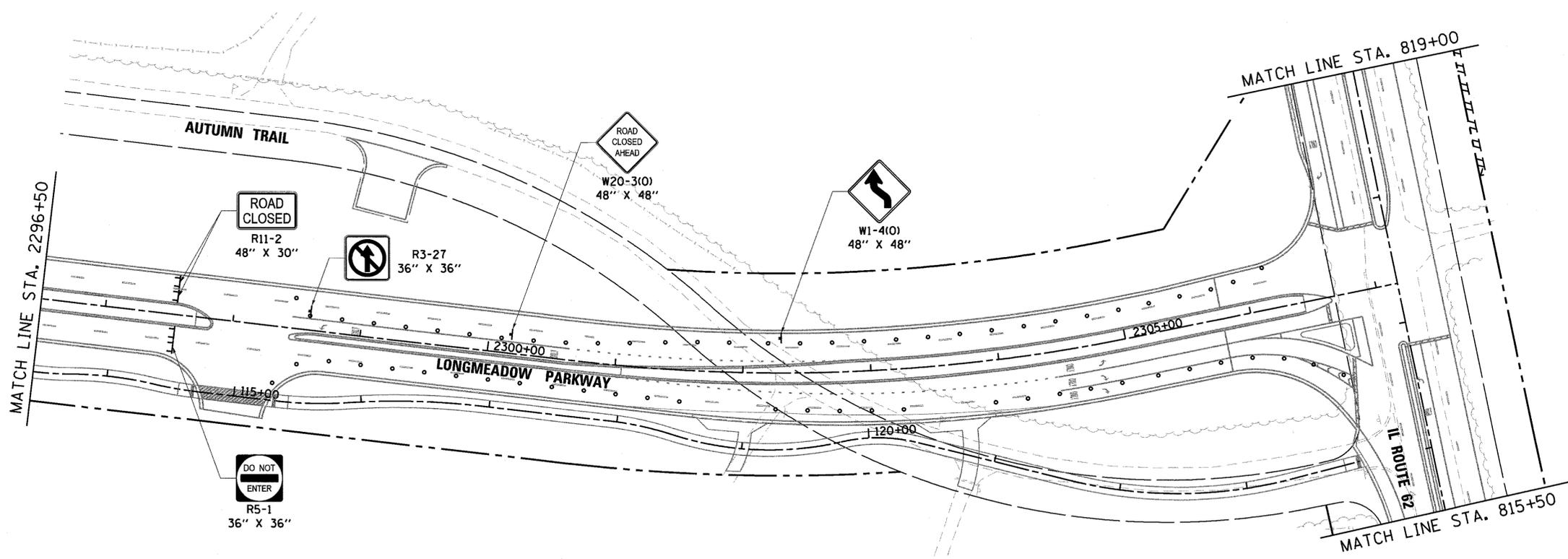

NOTES
 1. SEE MOT SHEETS FOR IL ROUTE 62 STAGING.

- LEGEND**
- BARRIER, TYPE III
 - - - TEMPORARY SIGNING
 - o DRUM WITH STEADY BURNING BI-DIRECTIONAL LIGHT AT 50' SPACING, 25' SPACING IN TAPER AND CURVES

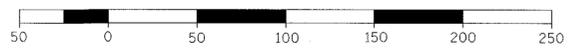

FILE NAME = 74754-ahc-rs-g-1.mxd



USER NAME = r.jiang	DESIGNED - RGJ	REVISED -
	DRAWN - RGJ	REVISED -
PLOT SCALE = 100,0000' / 1"	CHECKED - RMG	REVISED -
PLOT DATE = 9/1/2017	DATE - 9/5/2017	REVISED -

**STATE OF ILLINOIS
 DEPARTMENT OF TRANSPORTATION**

**MAINTENANCE OF TRAFFIC DETAILS
 INTERIM STAGE FOR LONGMEADOW DRIVEWAY ACCESS**

SCALE: 1" = 50' SHEET 1 OF 3 SHEETS STA. TO STA.

F.A.U. RTE. 2298	SECTION 13-00215-30-PV	COUNTY KANE	TOTAL SHEETS 177	SHEET NO. 43A
CONTRACT NO. 61D16			ILLINOIS FED. AID PROJECT	

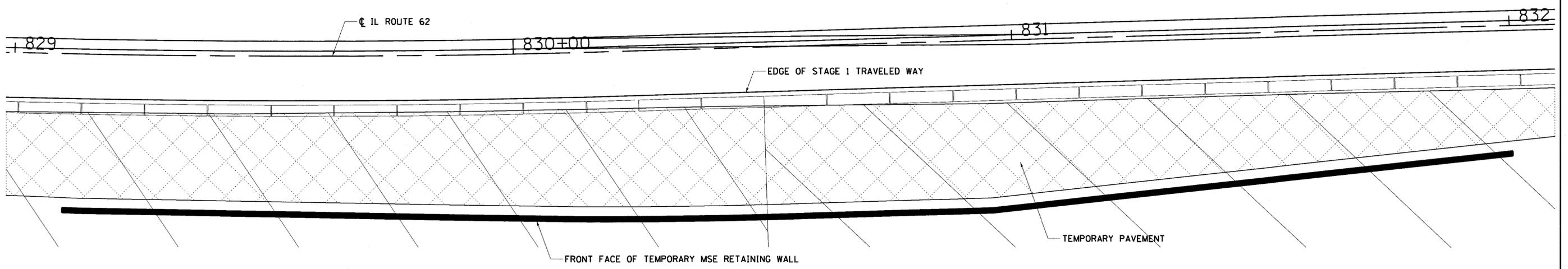
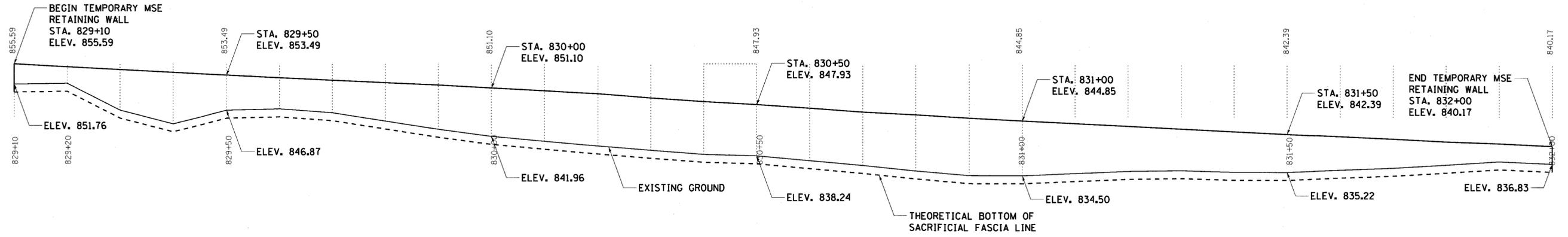

FILE NAME = 74754-ahh-mot-det-01.dgn

	USER NAME = rjjang	DESIGNED - JAR	REVISED -	STATE OF ILLINOIS DEPARTMENT OF TRANSPORTATION	MAINTENANCE OF TRAFFIC DETAILS		F.A.U. RTE. 2298	SECTION 13-00215-30-PV	COUNTY KANE	TOTAL SHEETS 177	SHEET NO. 44	
	PLOT SCALE = 20.0000' / 1" =	CHECKED - RMG	REVISED -				SCALE: SHEET 2 OF 3 SHEETS STA. TO STA.		CONTRACT NO. 61D16		ILLINOIS FED. AID PROJECT	
	PLOT DATE = 9/1/2017	DATE - 9/5/2017	REVISED -									

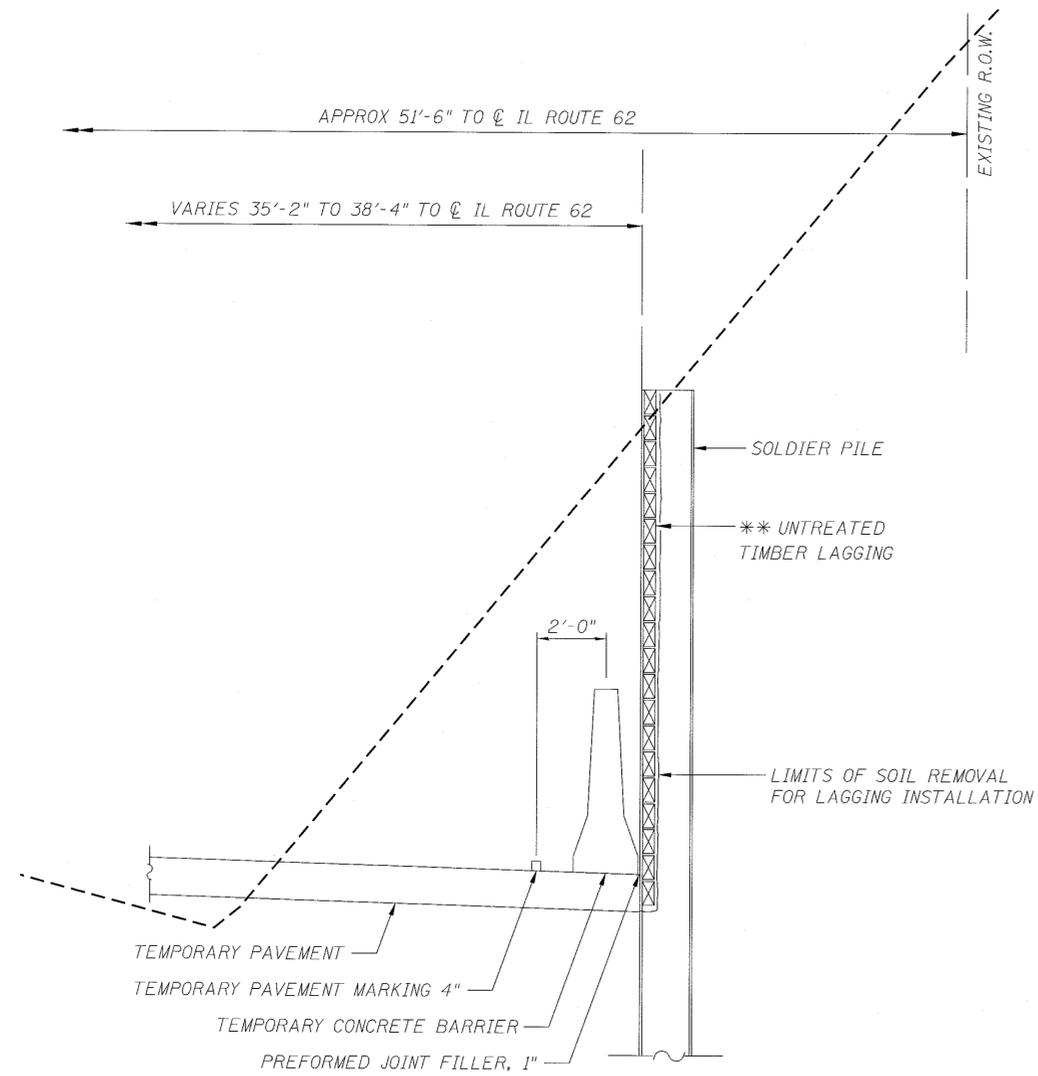

TEMPORARY CONCRETE BARRIER
AT RETAINING WALL 62A
TYPICAL SECTION

FILE NAME = 74754-at-mst-62a.dgn



USER NAME = r.jiang	DESIGNED - JAR	REVISED -
	DRAWN - RGJ	REVISED -
PLOT SCALE = 2.0000' / in.	CHECKED - RMG	REVISED -
PLOT DATE = 9/1/2017	DATE - 9/5/2017	REVISED -

STATE OF ILLINOIS
DEPARTMENT OF TRANSPORTATION

MAINTENANCE OF TRAFFIC DETAILS

SCALE: SHEET 3 OF 3 SHEETS STA. TO STA.

F.A.U. RTE.	SECTION	COUNTY	TOTAL SHEETS	SHEET NO.
2298	13-00215-30-PV	KANE	177	45
CONTRACT NO. 61D16				
<small>ILLINOIS FED. AID PROJECT</small>				

GENERAL NOTES

SEDIMENTATION AND EROSION CONTROL NOTES

1. EROSION CONTROL AND SEDIMENT CONTROL MEASURES SHALL BE IN ACCORDANCE WITH THE SWPPP FOR THE PROJECT AND THE FOLLOWING COMMENTS. ALL EROSION AND SEDIMENT CONTROL MEASURES WILL BE MAINTAINED IN ACCORDANCE WITH THE IDOT EROSION AND SEDIMENT CONTROL FIELD GUIDE FOR CONSTRUCTION INSPECTION AND IDOT'S BEST MANAGEMENT PRACTICES - MAINTENANCE GUIDE.
2. SOIL DISTURBANCE SHALL BE CONDUCTED IN SUCH A MANNER AS TO MINIMIZE EROSION. SOIL-STABILIZATION MEASURES SHALL CONSIDER THE TIME OF YEAR INCLUDING WINTER SHUT-DOWN, SITE CONDITIONS, AND THE USE OF TEMPORARY OR PERMANENT MEASURES.
3. SOIL-EROSION AND SEDIMENT-CONTROL FEATURES SHALL BE CONSTRUCTED PRIOR TO THE COMMENCEMENT OF LAND OR EARTH DISTURBANCE OF UPLAND AREAS.
4. THE DEPARTMENT HAS NOT OBTAINED ANY PERMITS FOR OFFSITE BORROW, WASTE, USE (BWU) AREAS. PRIOR TO WORKING IN BWU AREAS, IF THE CONTRACTOR CHOOSES TO USE ACTIVITIES REQUIRING PERMITS IT IS THE CONTRACTOR'S RESPONSIBILITY TO SECURE THE PROPER PERMITS. IN ADDITION TO THE BORROW REVIEW (BDE 2289) AND USE/WASTE REVIEW (BDE 2290) SUBMITTALS, THE CONTRACTOR SHALL SUBMIT AN EROSION AND SEDIMENT CONTROL (ESC) PLAN FOR EVERY BWU SITE TO THE DEPARTMENT FOR THEIR ACCEPTANCE. GUIDELINES FOR ACCEPTABLE BWU PRACTICES CAN BE FOUND IN SECTION IIG1 AND 2 OF THE SWPPP. THE COST OF ALL MATERIALS AND LABOR NECESSARY TO COMPLY WITH THE ABOVE PROVISIONS TO PREPARE AND IMPLEMENT ESC PLANS WILL NOT BE PAID FOR SEPARATELY, BUT SHALL BE CONSIDERED AS INCLUDED IN THE UNIT BID PRICES OF THE CONTRACT AND NO ADDITIONAL COMPENSATION WILL BE ALLOWED.
5. DISTURBED AREAS SHALL BE STABILIZED WITH TEMPORARY OR PERMANENT MEASURES AS SOON AS PRACTICAL IN PORTIONS OF THE SITE WHERE CONSTRUCTION ACTIVITIES HAVE TEMPORARILY OR PERMANENTLY CEASED, BUT IN NO CASE MORE THAN 1 DAY AFTER THE CONSTRUCTION ACTIVITY IN THAT PORTION OF THE SITE. FOR MORE DETAIL SEE STABILIZATION PRACTICES IN THE SWPPP.
6. TEMPORARY OR PERMANENT STABILIZATION SHALL BE INITIATED IMMEDIATELY UPON COMPLETION OF DISTURBANCE OR IF THE WORK AREA IS TO BE LEFT UNDISTURBED FOR 14 DAYS OR MORE.
7. UNDER NO CIRCUMSTANCES SHALL THE CONTRACTOR PROLONG FINAL GRADING AND SHAPING SO THAT THE ENTIRE PROJECT CAN BE PERMANENTLY SEEDED AT ONE TIME.
8. AREAS OR EMBANKMENTS HAVING SLOPES GREATER THAN 3H:1V SHALL BE STABILIZED WITH MAT, OR BLANKET IN COMBINATION WITH SEEDING.
9. EROSION-CONTROL BLANKET SHALL BE REQUIRED ON ALL INTERIOR DETENTION BASIN SIDE SLOPES BETWEEN NORMAL WATER LEVEL AND HIGH-WATER LEVEL.
10. ALL STORM SEWERS THAT ARE OR WILL BE FUNCTIONING DURING CONSTRUCTION SHALL BE PROTECTED BY AN APPROPRIATE SEDIMENT-CONTROL MEASURE AS FOUND IN THE SWPPP.
11. ALL TEMPORARY EROSION AND SEDIMENT-CONTROL MEASURES SHALL BE REMOVED WITHIN 30 DAYS AFTER FINAL SITE STABILIZATION IS ACHIEVED OR AFTER THE TEMPORARY MEASURES ARE NO LONGER NEEDED.
12. ALL TEMPORARY AND PERMANENT EROSION-CONTROL MEASURES MUST BE MAINTAINED AND REPAIRED AS NEEDED WITHIN 24 HOURS OF DISCOVERY BY THE CONTRACTOR. MAINTENANCE NOT PERFORMED IN A TIMELY FASHION MAY RESULT IN AN INCIDENCE OF NON-COMPLIANCE WITH A DEFICIENCY DEDUCTION AND/OR PENALTY AS DESCRIBED IN SECTION V OF THE SWPPP.
13. A STABILIZED MAT OF AGGREGATE UNDERLAIN WITH FILTER CLOTH (OR OTHER APPROPRIATE MEASURE) SHALL BE LOCATED AT ANY POINT WHERE TRAFFIC WILL BE ENTERING OR LEAVING A CONSTRUCTION SITE TO OR FROM A PUBLIC RIGHT-OF-WAY, STREET, OR PARKING AREA. ANY SEDIMENT OR SOIL REACHING AN IMPROVED PUBLIC RIGHT-OF-WAY OR STREET SHALL BE REMOVED BY SCRAPING OR STREET CLEANING AS ACCUMULATIONS WARRANT AND TRANSPORTED TO A CONTROLLED SEDIMENT-DISPOSAL AREA.
14. SOIL STOCKPILES SHALL NOT BE LOCATED IN A FLOOD-PRONE AREA OR A DESIGNATED BUFFER PROTECTING WATERS OF THE UNITED STATES.
15. IF DE-WATERING SERVICES ARE USED, ADJOINING PROPERTIES AND DISCHARGE LOCATIONS SHALL BE PROTECTED FROM EROSION. DISCHARGES SHALL BE ROUTED THROUGH AN EFFECTIVE SEDIMENT-CONTROL MEASURE (e.g., SEDIMENT TRAP, SEDIMENT BASIN, FILTER BAG OR OTHER APPROVED MEASURE).
16. THE EROSION-CONTROL MEASURES INDICATED ON THE PLANS ARE THE MINIMUM REQUIREMENTS. ADDITIONAL MEASURES MAY BE REQUIRED, AS DIRECTED BY THE ENGINEER OR GOVERNING AGENCY.
17. THE SITE SHOULD BE PHASED TO REDUCE THE AMOUNT OF STRIPPED, UNSTABILIZED AREA WITHIN THE SITE AT ANY ONE TIME. NO MORE THAN 10 ACRES ARE TO BE DISTURBED AT A TIME WITHOUT TEMPORARY OR PERMANENT STABILIZATION. MASS GRADING SHOULD BE AVOIDED TO PREVENT EROSION.

SEDIMENTATION AND EROSION CONTROL NOTES (CONT.)

18. THE CONDITION OF THE CONSTRUCTION SITE FOR WINTER SHUTDOWN SHALL BE ADDRESSED EARLY IN THE FALL GROWING SEASON SO THAT SLOPES AND OTHER BARE EARTH AREAS MAY BE STABILIZED WITH TEMPORARY AND/OR PERMANENT VEGETATIVE COVER FOR PROPER EROSION AND SEDIMENT CONTROL. ALL OPEN AREAS THAT ARE TO REMAIN IDLE THROUGHOUT THE WINTER SHALL RECEIVE TEMPORARY EROSION CONTROL MEASURES INCLUDING TEMPORARY SEEDING, MULCHING AND/OR EROSION CONTROL BLANKET PRIOR TO THE END OF THE FALL GROWING SEASON. THE AREAS TO BE WORKED BEYOND THE END OF THE GROWING SEASON MUST INCORPORATE SOIL STABILIZATION MEASURES THAT DO NOT RELY ON VEGETATIVE COVER SUCH AS EROSION CONTROL BLANKET AND HEAVY MULCHING.
19. CONTRACTOR TO PROVIDE RESIDENT ENGINEER A STABILIZED FLOW LINE PLAN TO BE USED DURING STORM SEWER CONSTRUCTION. LACK OF APPROVED PLAN OR FAILURE TO COMPLY WILL RESULT IN AS ESC DEFICIENCY DEDUCTION.
20. ANY LOOSE MATERIAL DEPOSITED IN THE FLOW LINE OF DRAINAGE STRUCTURES, WHICH OBSTRUCTS THE NATURAL FLOW OF WATER, SHALL BE REMOVED AT THE CLOSE OF EACH WORKING DAY. PRIOR TO ACCEPTANCE OF THE IMPROVEMENT, ALL DRAINAGE STRUCTURES SHALL BE FREE OF DIRT AND DEBRIS. THIS WORK WILL NOT BE PAID FOR SEPARATELY BUT SHALL BE CONSIDERED INCLUDED IN THE COST OF SEDIMENT CONTROL, DRAINAGE STRUCTURE INLET FILTER CLEANING.
21. THIS PROJECT REQUIRES A US ARMY CORP OF ENGINEERS (USACOE) 404 PERMIT THAT WILL BE SECURED BY THE DEPARTMENT. ALL CONDITIONS OF THE 404 PERMIT, FOUND IN THE SPECIAL PROVISIONS, MUST BE FOLLOWED. AS A CONDITION OF THIS PERMIT, THE CONTRACTOR WILL NEED TO SUBMIT A WORK PLAN FOR WORK WITHIN WETLANDS AND WOUS TO KDSWCD FOR APPROVAL. GUIDELINES ON ACCEPTABLE WORK TECHNIQUES FOR WORK IN WETLANDS AND WOUS CAN BE FOUND ON USACE WEBSITE. THE USACE DEFINES AND DETERMINES THE WORK. THE COST OF ALL MATERIALS AND LABOR NECESSARY TO COMPLY WITH THE ABOVE PROVISIONS TO PREPARE AND IMPLEMENT A WORK PLAN FOR WORK IN WETLANDS AND WOUS WILL NOT BE PAID FOR SEPARATELY, BUT SHALL BE CONSIDERED AS INCLUDED IN THE UNIT BID PRICES OF THE CONTRACT AND NO ADDITIONAL COMPENSATION WILL BE ALLOWED.

SCHEDULE OF SEEDING AND FERTILIZER NUTRIENTS

ITEM (UNIT)	APRIL 1 - JUNE 15, 2017	AUG 1 - NOV 1, 2017	TOTAL QUANTITY
SEEDING (ACRES)	-	11.75 ACRES	11.75 ACRES
NITROGEN FERTILIZER NUTRIENT (POUNDS)	- 90 LBS/ACRE	745 LBS 90 LBS/ACRE	745 LBS
POTASSIUM FERTILIZER NUTRIENT (POUNDS)	- 90 LBS/ACRE	745 LBS 90 LBS/ACRE	745 LBS

FILE NAME = 74754-shr-er-esc-gennotes.dgn



USER NAME = rjl:ang	DESIGNED - N/A	REVISED -
PLOT SCALE = 2.0000' / in.	DRAWN - CFZ	REVISED -
PLOT DATE = 9/29/2017	CHECKED - RMG	REVISED -
	DATE - 9/5/2017	REVISED -

**STATE OF ILLINOIS
DEPARTMENT OF TRANSPORTATION**

**EROSION CONTROL PLAN
GENERAL NOTES**

SCALE: SHEET 1 OF 1 SHEETS STA. TO STA.

F.A.U. RTE. 2298	SECTION 13-00215-30-PV	COUNTY KANE	TOTAL SHEETS 177	SHEET NO. 46
			CONTRACT NO. 61D16	
ILLINOIS FED. AID PROJECT				

LEGEND

-  EROSION CONTROL BLANKET (MODIFIED) & TEMPORARY EROSION CONTROL SEEDING
-  HEAVY DUTY EROSION CONTROL BLANKET, SPECIAL & TEMPORARY EROSION CONTROL SEEDING
-  STABILIZED CONSTRUCTION ENTRANCE
-  INLET FILTERS
-  TEMPORARY DITCH CHECKS
-  PERIMETER EROSION BARRIER, SPECIAL
-  CONCRETE TRUCK WASHOUT

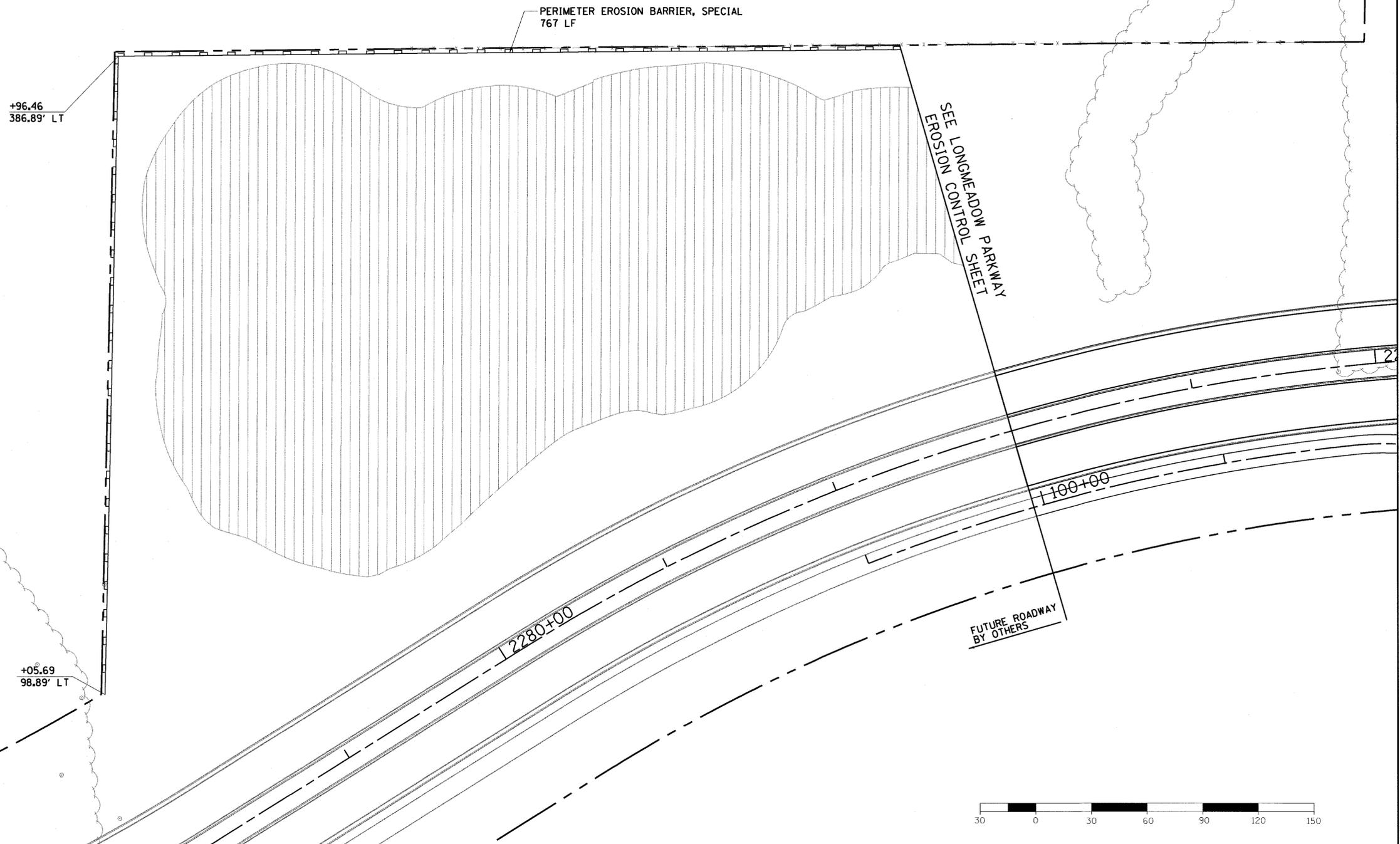

FILE NAME = 74754-ahc-eros08basin.dgn



USER NAME = r.jiang	DESIGNED - RGJ	REVISED -
DRAWN - RGJ	REVISOR -	
PLOT SCALE = 60.0000' / 1" =	CHECKED - CFZ	REVISOR -
PLOT DATE = 9/1/2017	DATE - 9/5/2017	REVISOR -

**STATE OF ILLINOIS
DEPARTMENT OF TRANSPORTATION**

**EROSION CONTROL PLAN
DETENTION BASIN**

SCALE: 1" = 30' SHEET 1 OF 8 SHEETS STA. TO STA.

F.A.U. RTE.	SECTION	COUNTY	TOTAL SHEETS	SHEET NO.
2298	13-00215-30-PV	KANE	177	47
CONTRACT NO. 61D16				
ILLINOIS FED. AID PROJECT				

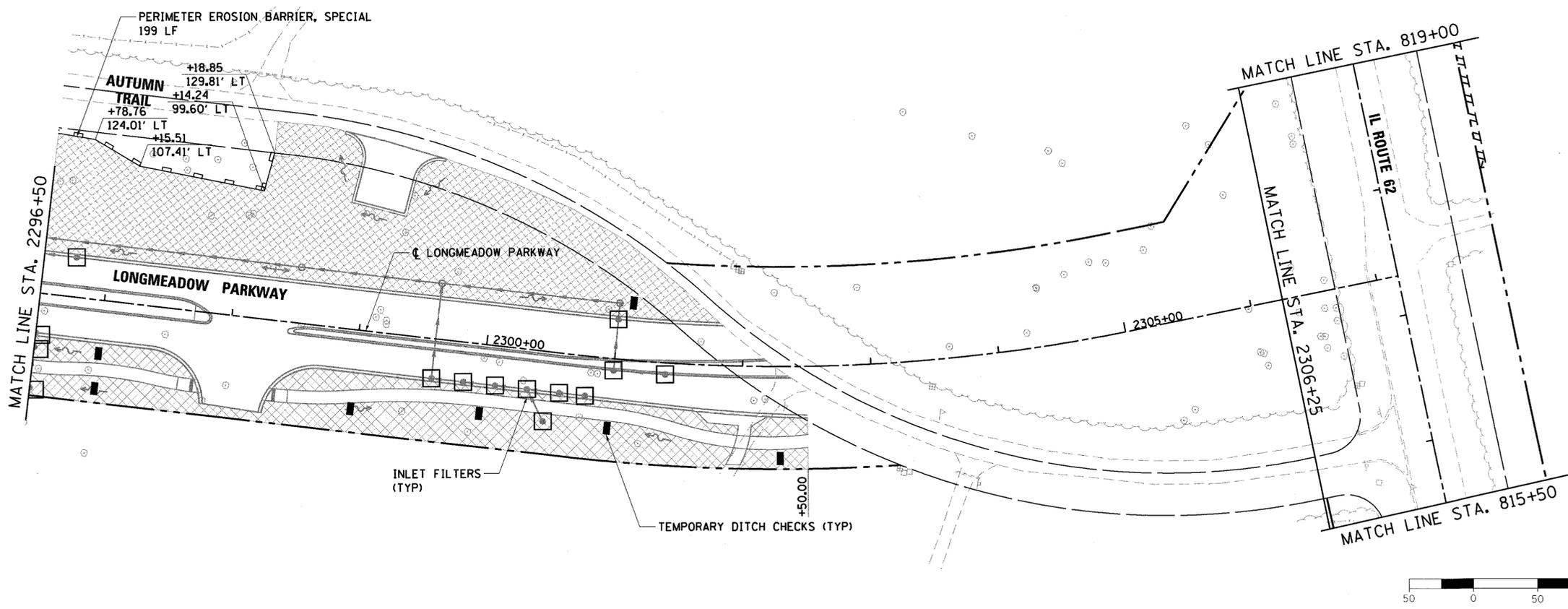
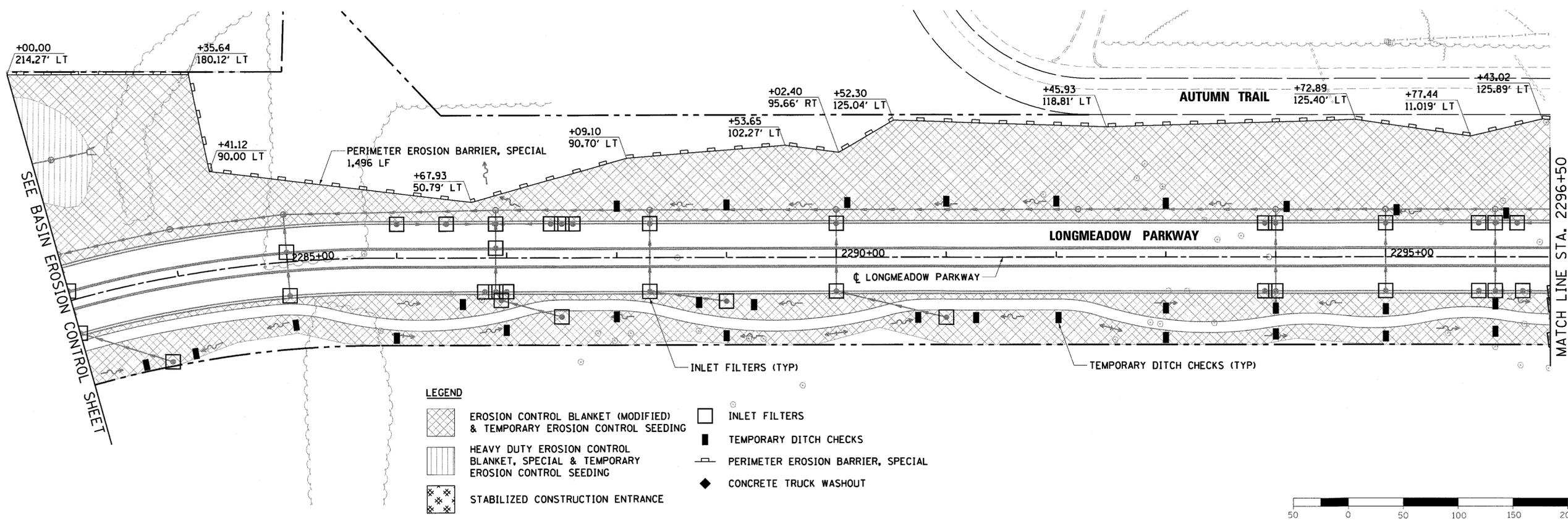

FILE NAME = 74754-ant-eros.dwg



USER NAME = rjjang
 PLOT SCALE = 100.0000' / 1" =
 PLOT DATE = 9/1/2017

DESIGNED - RGJ
 DRAWN - RGJ
 CHECKED - RMG
 DATE - 9/5/2017

REVISED -
 REVISED -
 REVISED -
 REVISED -

STATE OF ILLINOIS
 DEPARTMENT OF TRANSPORTATION

EROSION CONTROL PLAN
 STAGE 1
 SCALE: 1" = 50' SHEET 1 OF 8 SHEETS STA. 2283+00.00 TO STA. 2307+16.89

F.A.U. RTE.	SECTION	COUNTY	TOTAL SHEETS	SHEET NO.
2298	13-00215-30-PV	KANE	177	48
CONTRACT NO. 61D16				
ILLINOIS FED. AID PROJECT				



LEGEND

-  EROSION CONTROL BLANKET (MODIFIED) & TEMPORARY EROSION CONTROL SEEDING
-  HEAVY DUTY EROSION CONTROL BLANKET, SPECIAL & TEMPORARY EROSION CONTROL SEEDING
-  STABILIZED CONSTRUCTION ENTRANCE
-  INLET FILTERS
-  TEMPORARY DITCH CHECKS
-  PERIMETER EROSION BARRIER, SPECIAL
-  CONCRETE TRUCK WASHOUT

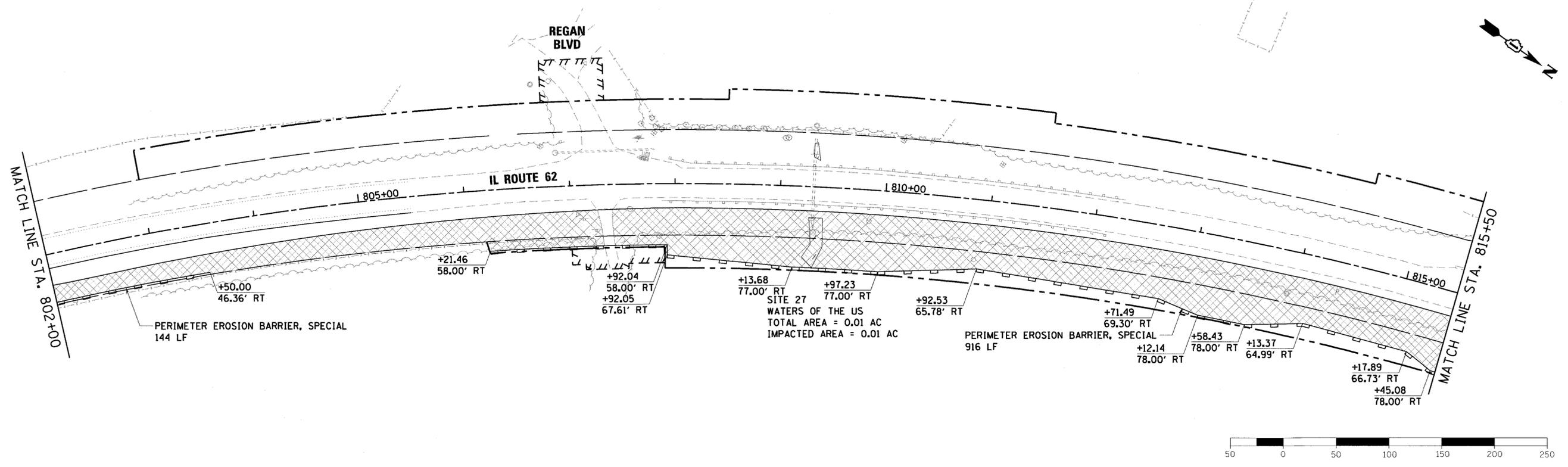

FILE NAME = 74754-shr-eroca01b.dgn

BURNS MCDONNELL	USER NAME = r.jiang	DESIGNED - RGJ	REVISED -	STATE OF ILLINOIS DEPARTMENT OF TRANSPORTATION	EROSION CONTROL PLAN STAGE 1	F.A.U. RTE. 2298	SECTION 13-00215-30-PV	COUNTY KANE	TOTAL SHEETS 177	SHEET NO. 49	
	PLOT SCALE = 1/8" = 10'-0"	CHECKED - RMG	REVISED -			SCALE: 1" = 50' SHEET 2 OF 8 SHEETS STA. 794+00.00 TO STA. 815+50.00		CONTRACT NO. 61D16			
	PLOT DATE = 9/1/2017	DATE - 9/5/2017	REVISED -			ILLINOIS FED. AID PROJECT					

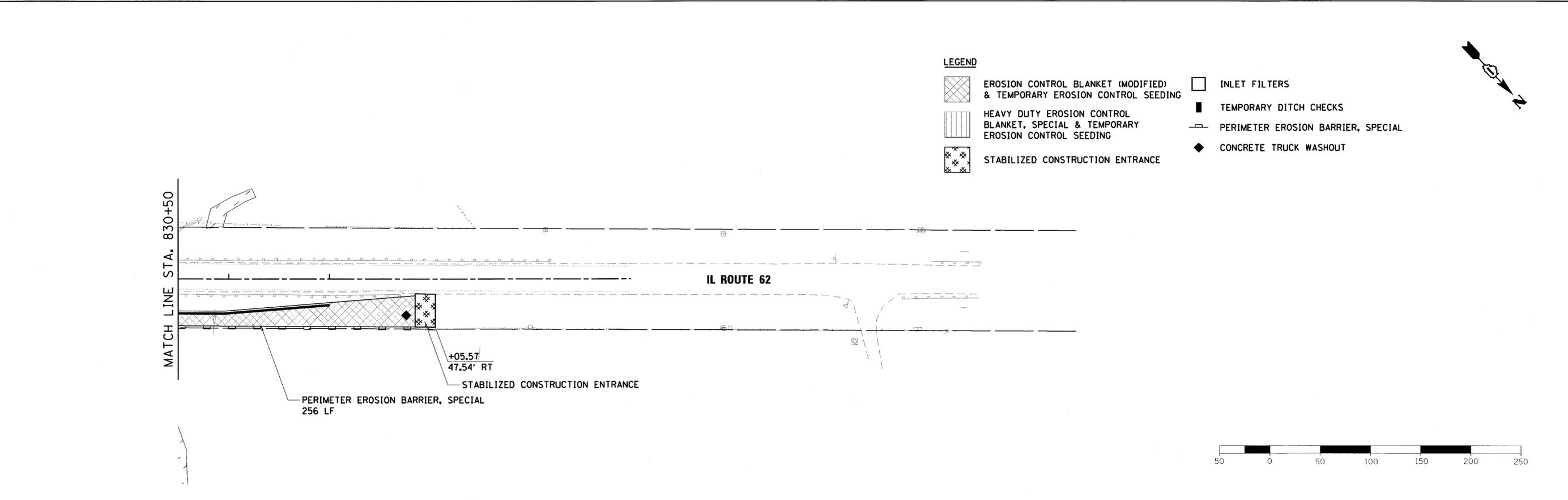
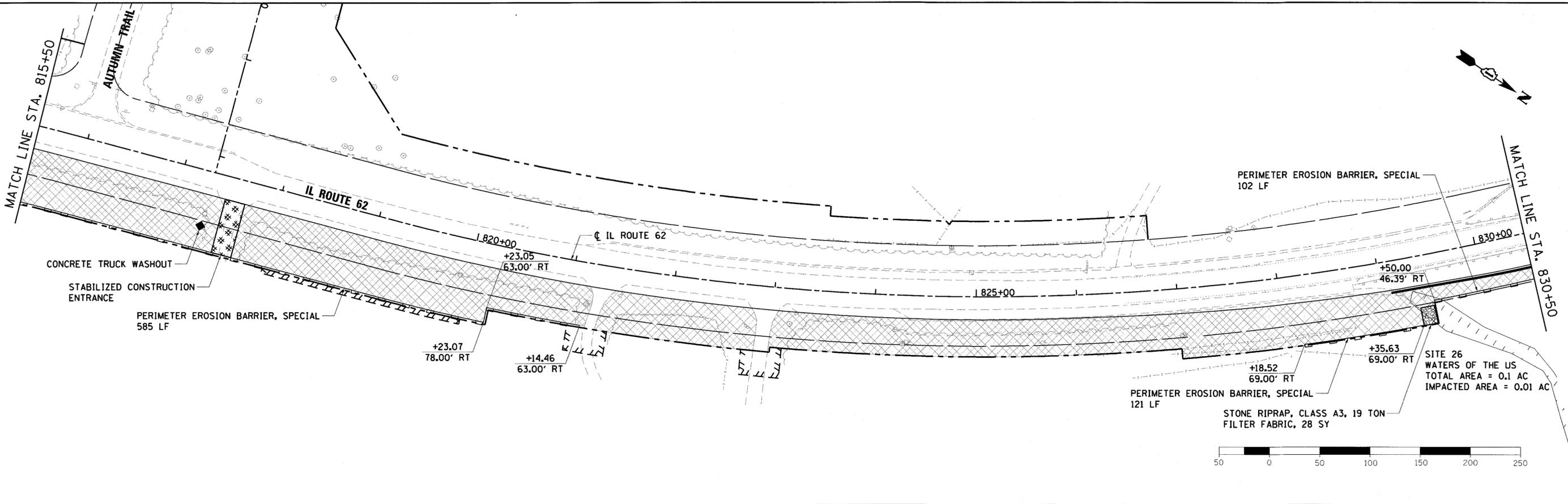

- LEGEND**
- EROSION CONTROL BLANKET (MODIFIED) & TEMPORARY EROSION CONTROL SEEDING
 - HEAVY DUTY EROSION CONTROL BLANKET, SPECIAL & TEMPORARY EROSION CONTROL SEEDING
 - STABILIZED CONSTRUCTION ENTRANCE
 - INLET FILTERS
 - TEMPORARY DITCH CHECKS
 - PERIMETER EROSION BARRIER, SPECIAL
 - CONCRETE TRUCK WASHOUT

FILE NAME = 74754-shr-eros01.dgn

	USER NAME = r.jiang	DESIGNED - RGJ	REVISED -	STATE OF ILLINOIS DEPARTMENT OF TRANSPORTATION	EROSION CONTROL PLAN STAGE 1			F.A.U. RTE.	SECTION	COUNTY	TOTAL SHEETS	SHEET NO.
	PLOT SCALE = 100.0000' / 1" =	DRAWN - RGJ	REVISED -		2298	13-00215-30-PV	KANE	177	50			
	PLOT DATE = 9/1/2017	CHECKED - RMG	REVISED -		CONTRACT NO. 61D16			ILLINOIS FED. AID PROJECT				
				SCALE: 1" = 50'				SHEET 3 OF 8 SHEETS		STA. 815+50.00 TO STA. 835+00.00		

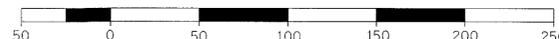
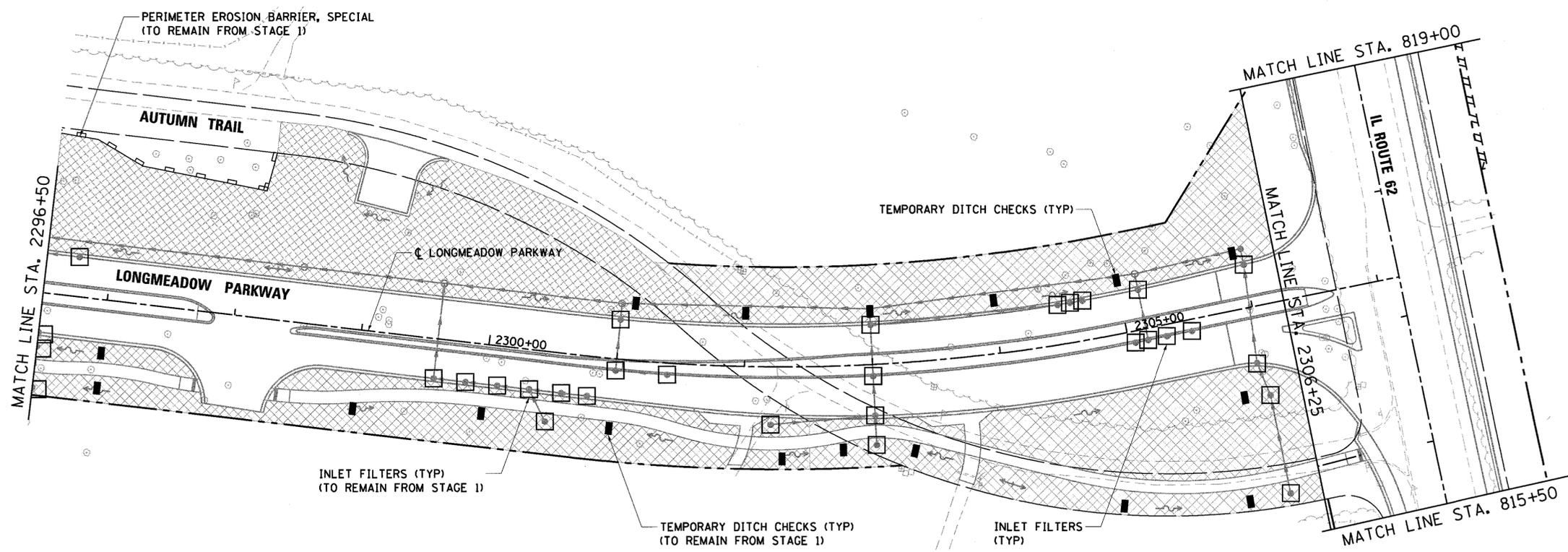
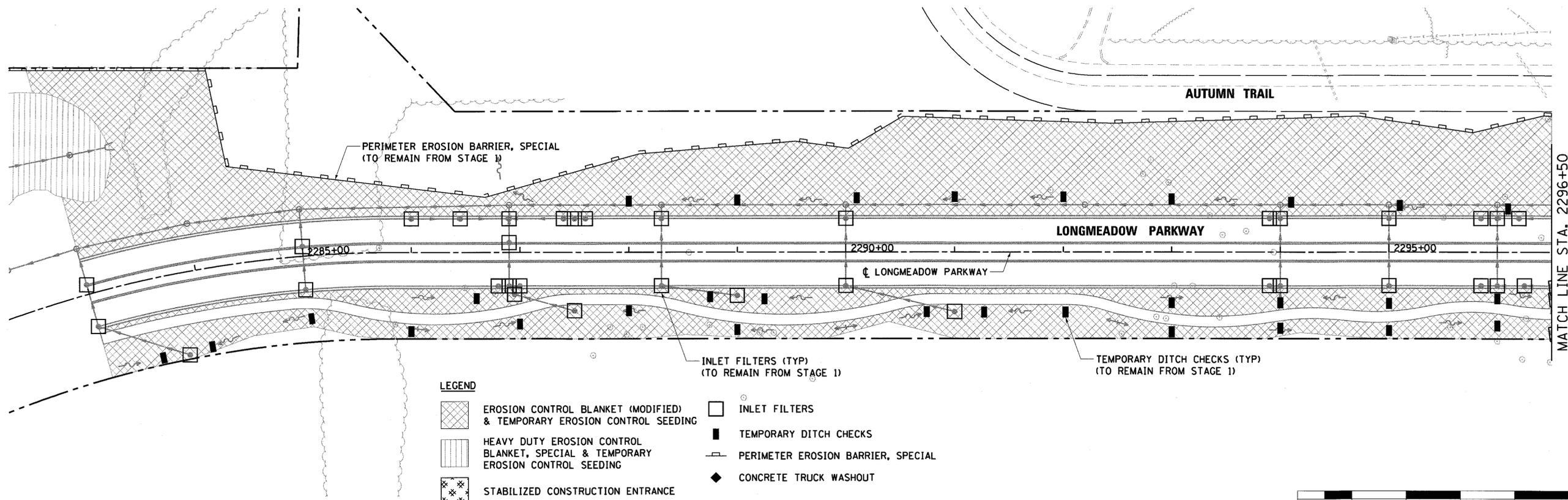

FILE NAME = 74754-ahc-eroc2a.dgn



USER NAME = rjiang	DESIGNED - RGJ	REVISED -
DRAWN - RGJ	CHECKED - RMG	REVISED -
DATE - 9/5/2017		

**STATE OF ILLINOIS
DEPARTMENT OF TRANSPORTATION**

**EROSION CONTROL PLAN
STAGE 2**
SCALE: 1" = 50' SHEET 4 OF 8 SHEETS STA. 2283+00.00 TO STA. 2307+16.89

F.A.I.L. RTE.	SECTION	COUNTY	TOTAL SHEETS	SHEET NO.
2298	13-00215-30-PV	KANE	177	51
CONTRACT NO. 61D16			ILLINOIS FED. AID PROJECT	

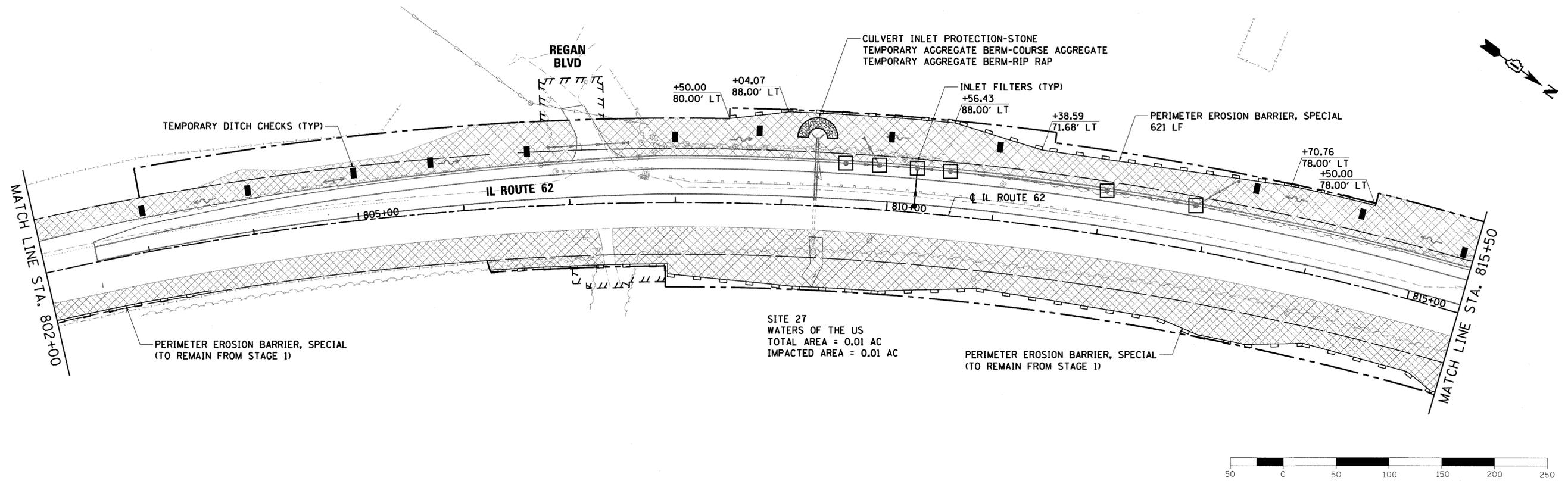
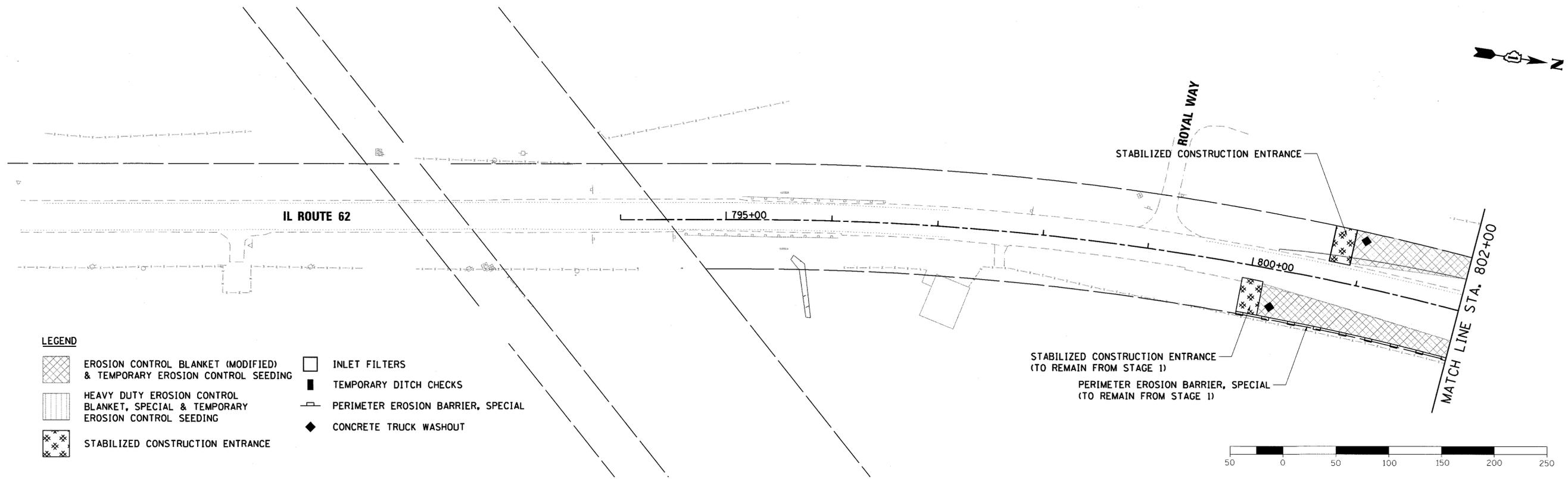

FILE NAME = 74754-shit-eros02b.dgn

	USER NAME = r.jiang	DESIGNED - RGJ	REVISED -	STATE OF ILLINOIS DEPARTMENT OF TRANSPORTATION	EROSION CONTROL PLAN STAGE 2			F.A.U. RTE. 2298	SECTION 13-00215-30-PV	COUNTY KANE	TOTAL SHEETS 177	SHEET NO. 52			
	PLOT SCALE = 100.0000' / 1" =	CHECKED - RMG	REVISED -					SCALE: 1" = 50'			SHEET 5 OF 8 SHEETS STA. 794+00.00 TO STA. 815+50.00			CONTRACT NO. 61D16	
	PLOT DATE = 9/1/2017	DATE = 9/5/2017	REVISED -								ILLINOIS FED. AID PROJECT				

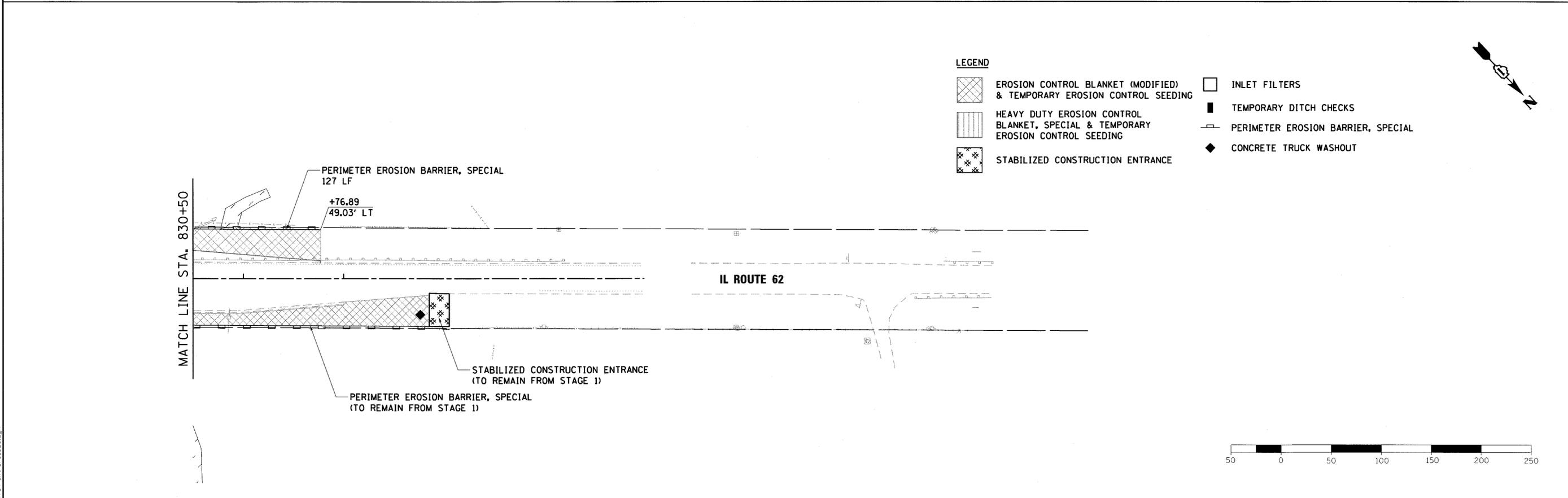
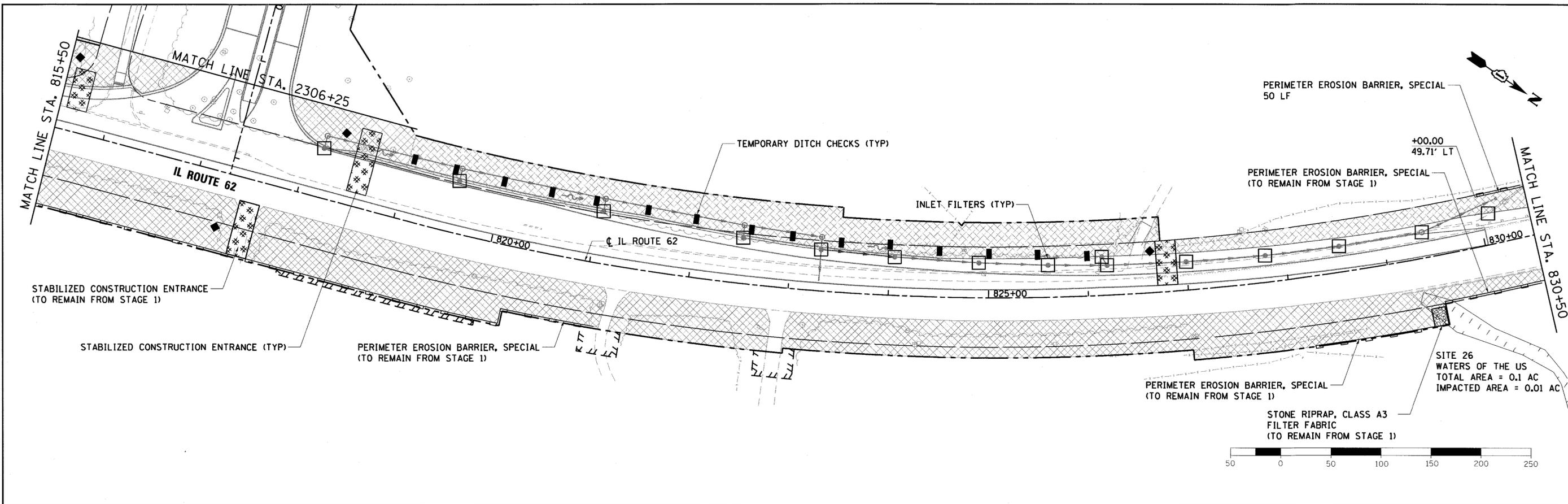

LEGEND

-  EROSION CONTROL BLANKET (MODIFIED) & TEMPORARY EROSION CONTROL SEEDING
-  HEAVY DUTY EROSION CONTROL BLANKET, SPECIAL & TEMPORARY EROSION CONTROL SEEDING
-  STABILIZED CONSTRUCTION ENTRANCE
-  INLET FILTERS
-  TEMPORARY DITCH CHECKS
-  PERIMETER EROSION BARRIER, SPECIAL
-  CONCRETE TRUCK WASHOUT

FILE NAME = 74754-ahtrerc02.dgn



USER NAME = r.j.ang	DESIGNED - RGJ	REVISED -
DRAWN - RGJ	REVISOR -	
PLOT SCALE = 100.0000' / 1" =	CHECKED - RMG	REVISED -
PLOT DATE = 9/1/2017	DATE - 9/5/2017	REVISED -

**STATE OF ILLINOIS
DEPARTMENT OF TRANSPORTATION**

**EROSION CONTROL PLAN
STAGE 2**

SCALE: 1" = 50' SHEET 6 OF 8 SHEETS STA. 815+50.00 TO STA. 835+00.00

F.A.U. RTE.	SECTION	COUNTY	TOTAL SHEETS	SHEET NO.
2298	13-00215-30-PV	KANE	177	53
CONTRACT NO. 61D16			ILLINOIS FED. AID PROJECT	

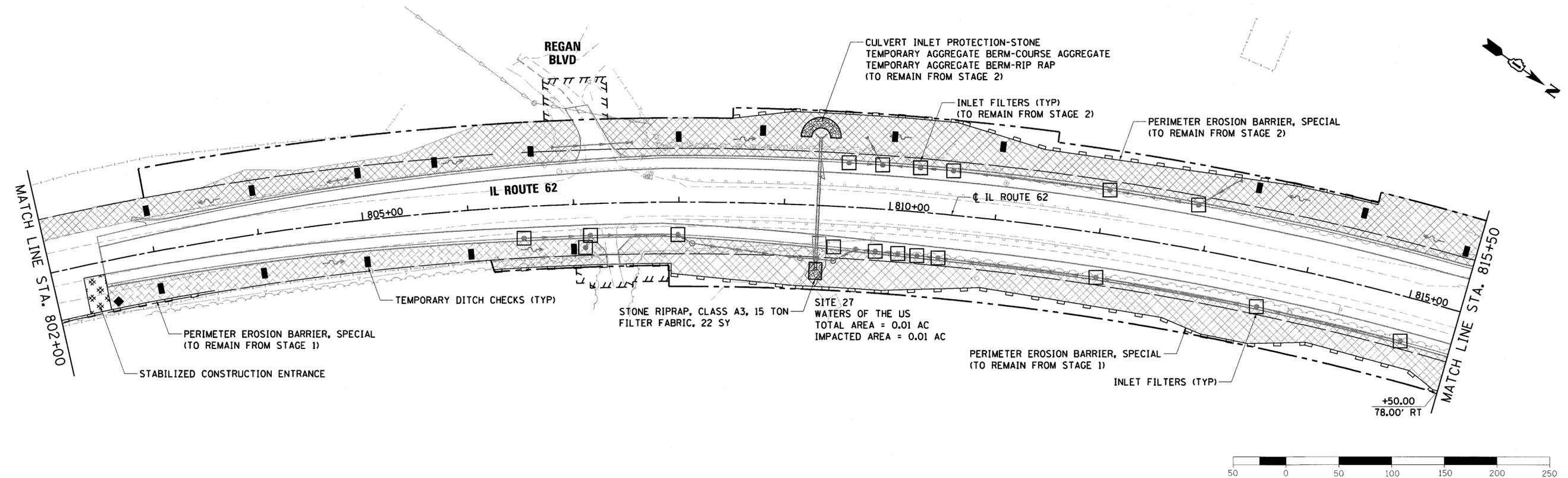
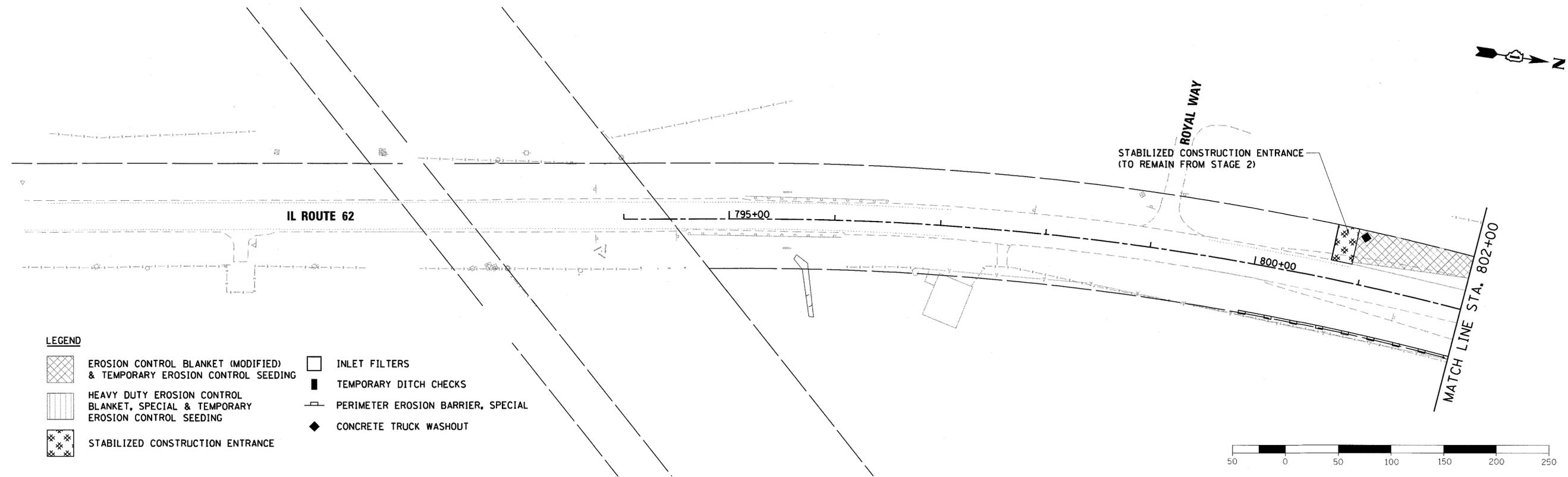

FILE NAME = 74794-ah1-eros023a.dgn



USER NAME = rjlang	DESIGNED - RGJ	REVISED -
	DRAWN - RGJ	REVISED -
PLOT SCALE = 100.0000' / 1" =	CHECKED - RMG	REVISED -
PLOT DATE = 9/1/2017	DATE - 9/5/2017	REVISED -

**STATE OF ILLINOIS
DEPARTMENT OF TRANSPORTATION**

**EROSION CONTROL PLAN
STAGE 3**
SCALE: 1" = 50' SHEET 7 OF 8 SHEETS STA. 794+00.00 TO STA. 815+50.00

F.A.J. RTE. 2298	SECTION 13-00215-30-PV	COUNTY KANE	TOTAL SHEETS 177	SHEET NO. 54
				CONTRACT NO. 61D16
ILLINOIS FED. AID PROJECT				

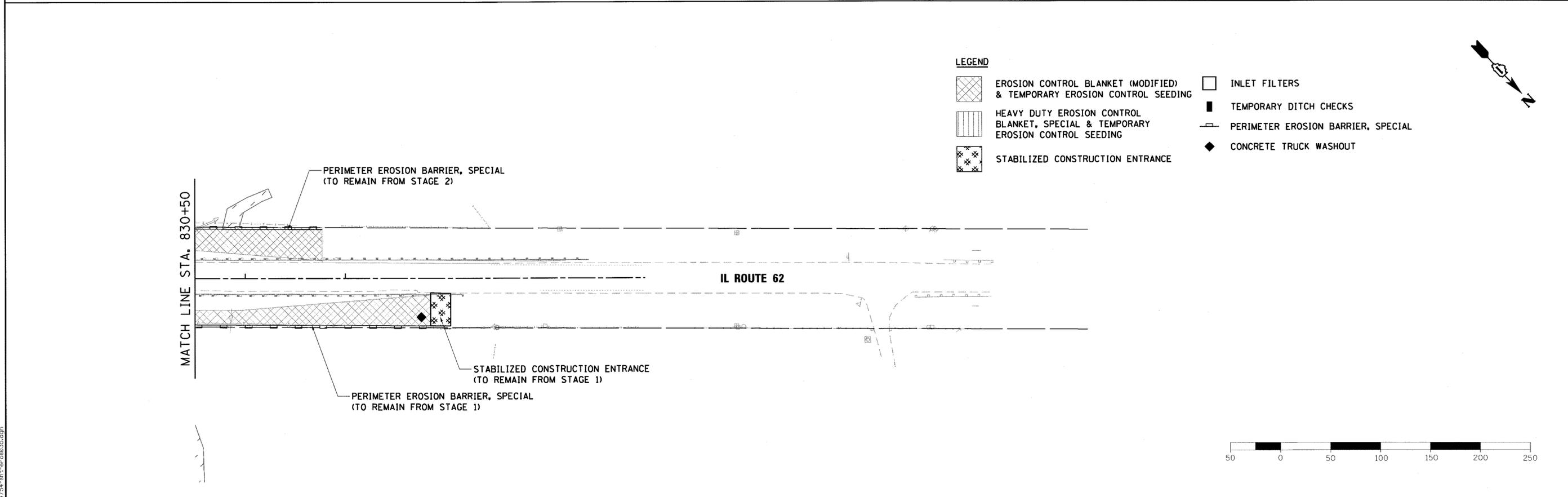
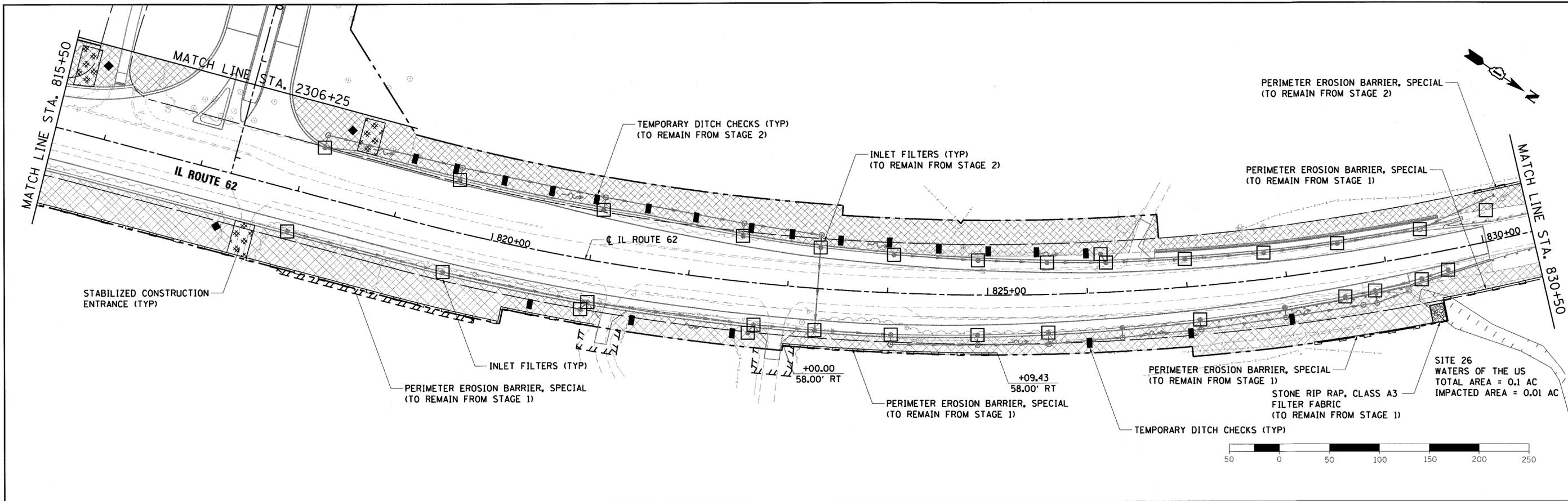

FILE NAME = 74754-ah-er-03b.dgn



USER NAME = r.jiang	DESIGNED - RGJ	REVISED -
DRAWN - RGJ	REVISIONS -	
PLLOT SCALE = 100.0000' / 1"	CHECKED - RMG	REVISED -
PLLOT DATE = 9/17/2017	DATE - 9/5/2017	REVISED -

**STATE OF ILLINOIS
DEPARTMENT OF TRANSPORTATION**

**EROSION CONTROL PLAN
STAGE 3**

SCALE: 1" = 50' SHEET 8 OF 8 SHEETS STA. 815+50.00 TO STA. 835+00.00

F.A.U. RTE.	SECTION	COUNTY	TOTAL SHEETS	SHEET NO.
2298	13-00215-30-PV	KANE	177	55
CONTRACT NO. 61D16				
ILLINOIS FED. AID PROJECT				

EROSION CONTROL BLANKET - TURF REINFORCEMENT MAT (TRM)

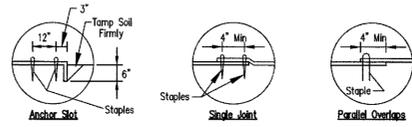
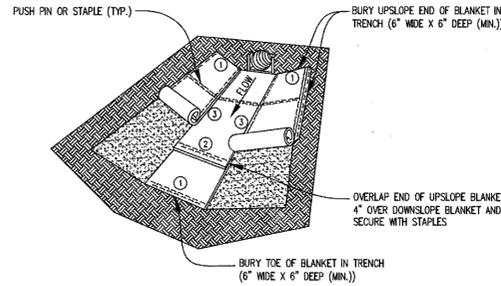

DETAIL 1

DETAIL 2

DETAIL 3

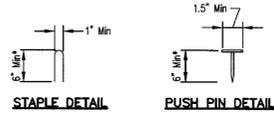

STAPLE DETAIL

PUSH PIN DETAIL

Note: 1. For sandy soil conditions, staple or push pin shall be a minimum 8 inches.

REFERENCE Project	DESIGNED Date	STANDARD DWG. NO. IUM-531
CHECKED Date	APPROVED Date	SHEET 1 OF 1
APPROVED Date		DATE 02-22-11

PLANTING PROCEDURE FOR BALLED AND BURLAPPED OR CONTAINER GROWN TREES AND SHRUBS

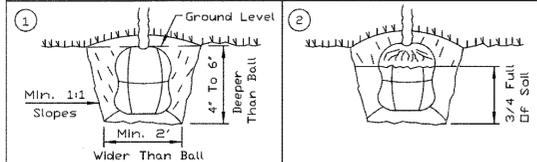

Add enough tamped soil in the bottom of the hole to set the ball at or slightly higher than the original planting depth.

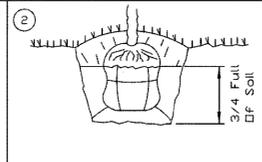

Fill the hole 3/4 full of tamped soil then remove all exposed burlap and wire using a sharp utility knife.

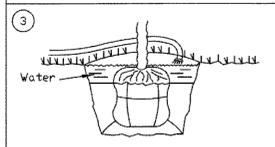

Fill the remaining 1/4 of the hole with water to remove air pockets and settle the soil. Finish filling the hole with soil after all the water has drained.

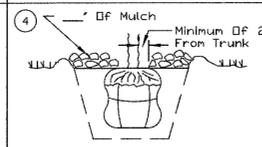

Unless soil is poorly drained, mound soil around edges of hole 4\"/>

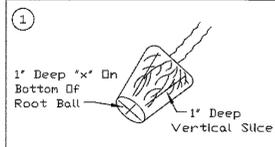

Cut the circling roots of container grown trees with a sharp utility knife. Make 4 vertical slices on the sides and an 'x' on the bottom. All slices should be 1-inch in depth.

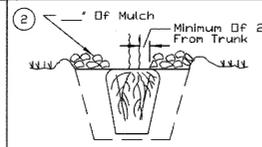

Plant container-grown trees using same steps as for B & B trees except that the plastic container should be completely removed.

REFERENCE Project	DESIGNED Date	STANDARD DWG. NO. IL-685
CHECKED Date	APPROVED Date	SHEET 1 OF 1
APPROVED Date		DATE 0-22-94

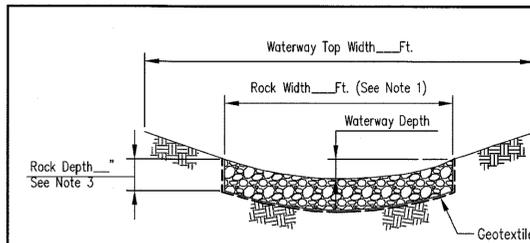

SECTION B-B

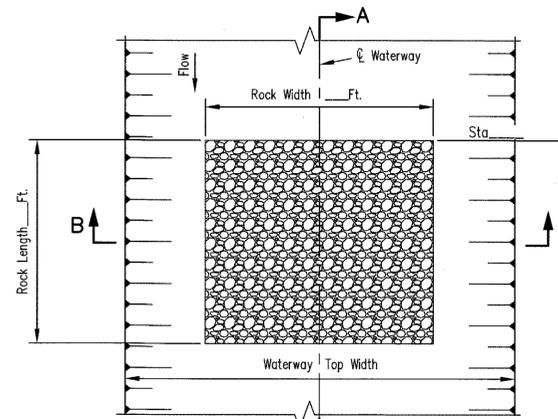

PLAN VIEW

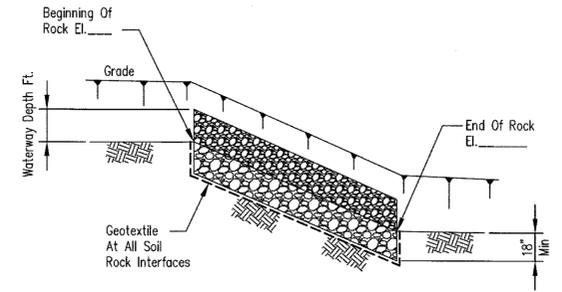

SECTION A-A

- Notes:
- Minimum rock width is 2/3 of full waterway top width.
 - Set rock surface to match waterway shape.
 - Minimum rock depth is 18 inches.
 - Maximum lined waterway slope is 15%, not to exceed 7 ft./sec design velocity.
 - Geotextile (non-woven, needle punched) Minimum criteria:
 - Grab tensile strength (lb) ASTM D 4632 _____ 202
 - Elongation at failure (%) ASTM D 4632 _____ ≥ 50
 - Trapezoidal tear strength (lb) ASTM D 4533 _____ 79
 - Puncture strength (lb) ASTM D 6241 _____ 433
 - Ultraviolet light (% retained strength) ASTM D 4355 _____ min 50
 - Apparent opening size (AOS) ASTM D 4751 _____ max 0.22 mm (US sieve size 70)
 - Any geotextile splices shall overlap a minimum of 18 inches, with upstream or upslope geotextile overlapping the abutting downslope geotextile.
- Quantities:
 Geotextile _____ Sq. Yd.
 Riprap IDOT GRAD. NO. 4 Quality Designation A _____ Ton

DESIGNED: _____ DATE: _____
 CHECKED: _____ DATE: _____
 APPROVED: _____ DATE: _____

FILE NO. IL-ENG-31
 SHEET 1 OF 1

NRCS
 National Resource Conservation Service
 United States Department of Agriculture

Pipe Outlet To Flat Area No Well-Defined Channel

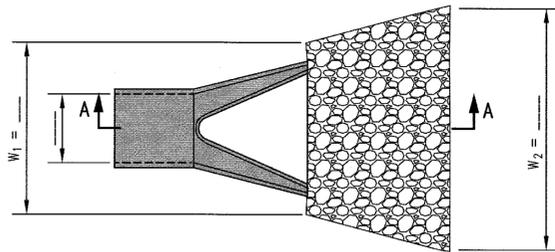

PLAN

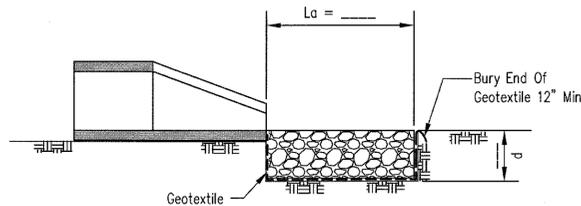

SECTION A-A

- NOTES:
- The rock riprap shall meet IDOT requirements for Gradation No. _____, Quality Designation "A" or as designated by engineer.
 - Geotextile (non-woven, needle punched) Minimum criteria:
 - Grab tensile strength (lb) ASTM D 4632 _____ 202
 - Elongation at failure (%) ASTM D 4632 _____ ≥ 50
 - Trapezoidal tear strength (lb) ASTM D 4533 _____ 79
 - Puncture strength (lb) ASTM D 6241 _____ 433
 - Ultraviolet light (% retained strength) ASTM D 4355 _____ min 50
 - Apparent opening size (AOS) ASTM D 4751 _____ max 0.22 mm (US sieve size 70)
 - Permittivity sec⁻¹/ ASTM D 4491 _____ min 0.70
 - Any geotextile splices shall overlap a minimum of 18 inches, with upstream or upslope geotextile overlapping the abutting downslope geotextile.
 - Apron width W₁ shall be at least 3 times the culvert pipe diameter. Apron width W₂ shall be at least to L_a plus the pipe diameter.
 - Rock thickness d shall be at least 1.5 times the riprap D₁₀₀ size.
 - Apron length L_a and rock riprap shall be sized according to Illinois Urban Manual Rock Outlet Protection standard 910 minimum L_a = 10 ft.

DESIGNED: _____ DATE: _____
 CHECKED: _____ DATE: _____
 APPROVED: _____ DATE: _____

FILE NO. IL-ENG-44
 SHEET 1 OF 1

NRCS
 National Resource Conservation Service
 United States Department of Agriculture

Pipe Outlet To Well-Defined Channel

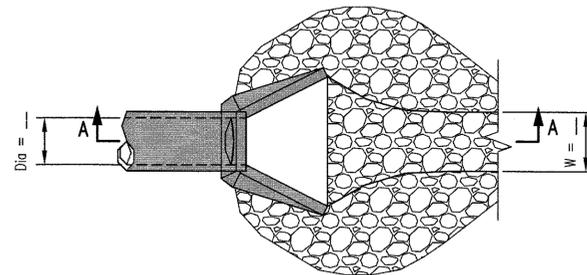

PLAN

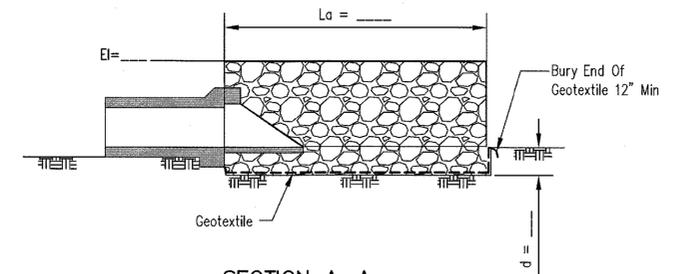

SECTION A-A

- NOTES:
- The rock riprap shall meet IDOT requirements for Gradation No. _____, Quality Designation "A" or as designated by engineer.
 - Geotextile (non-woven, needle punched) Minimum criteria:
 - Grab tensile strength (lb) ASTM D 4632 _____ 202
 - Elongation at failure (%) ASTM D 4632 _____ ≥ 50
 - Trapezoidal tear strength (lb) ASTM D 4533 _____ 79
 - Puncture strength (lb) ASTM D 6241 _____ 433
 - Ultraviolet light (% retained strength) ASTM D 4355 _____ min 50
 - Apparent opening size (AOS) ASTM D 4751 _____ max 0.22 mm (US sieve size 70)
 - Permittivity sec⁻¹/ ASTM D 4491 _____ min 0.70
 - Any geotextile splices shall overlap a minimum of 18 inches, with upstream or upslope geotextile overlapping the abutting downslope geotextile.
 - Apron shall extend across the channel bottom and up the channel banks to an elevation one foot above the maximum tailwater depth or to the top of bank.
 - Rock thickness d shall be at least 1.5 times the riprap D₁₀₀ size.
 - Apron length L_a and rock riprap shall be sized according to Illinois Urban Manual Rock Outlet Protection standard 910 minimum L_a = 10 ft.

DESIGNED: _____ DATE: _____
 CHECKED: _____ DATE: _____
 APPROVED: _____ DATE: _____

FILE NO. IL-ENG-45
 SHEET 1 OF 1

NRCS
 National Resource Conservation Service
 United States Department of Agriculture

FILE NAME = 74754-ent-eccs01.dgn



USER NAME = r.jiang	DESIGNED - N/A	REVISED -
DRAWN - RGJ	CHECKED - RMG	REVISED -
DATE - 9/5/2017		

STATE OF ILLINOIS
 DEPARTMENT OF TRANSPORTATION

STORMWATER POLLUTION PREVENTION PLAN DETAILS

SCALE: SHEET 1 OF 3 SHEETS STA. TO STA.

F.A.U. RTE. 2298	SECTION 13-00215-30-PV	COUNTY KANE	TOTAL SHEETS 177	SHEET NO. 56
CONTRACT NO. 61D16				ILLINOIS FED. AID PROJECT

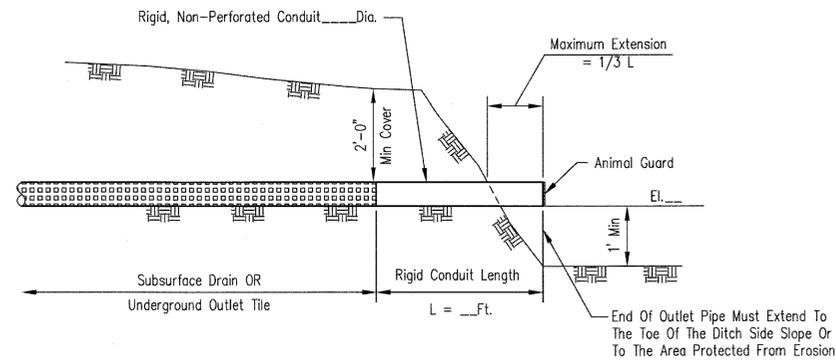

CROSS SECTION AT CENTERLINE OF PIPE

TILE OUTLET DETAIL



IL-ENG-85

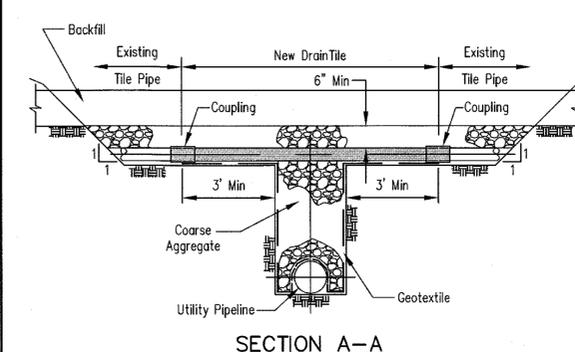

SECTION A-A

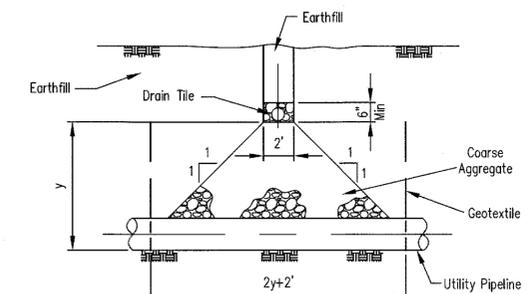

SECTION B-B

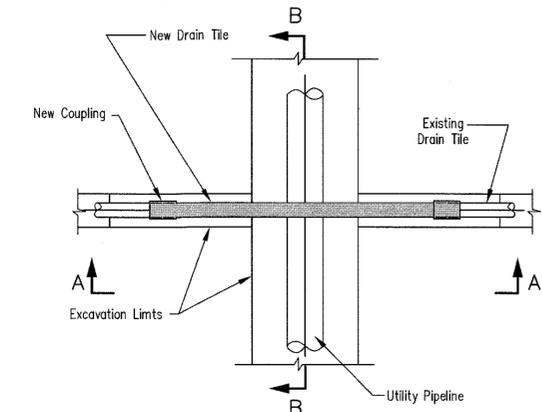

EXCAVATION PLAN

- NOTES:
- Coarse aggregate shall be gravel, crushed gravel, pit run gravel or crushed stone and shall conform to the requirements of IDOT Standard Specification for Road and Bridge Construction Article 1004.01 and CA-18 gradation.
 - Geotextile (non-woven, needle punched) min. criteria:
 Grab Tensile strength (lb) ASTM D 4632 _____ 202
 Elongation at failure (%) ASTM D 4632 _____ ≥50
 Trapezoidal tear strength (lb) ASTM D 4533 _____ 79
 Puncture strength (lb) ASTM D 6241 _____ 433
 Ultraviolet light (% retained strength) ASTM 4355 _____ min 50
 Apparent opening size (AOS) ASTM D 4751 _____ max 0.22 mm (US sieve size 70)
 Permittivity sec⁻¹/ ASTM D 4491 _____ min 0.7
 - Any geotextile splices shall overlap a minimum of 18 inches, with upstream or upslope geotextile overlapping the abutting downslope geotextile.
 - New tile should be equal to or better than existing tile. Dual Wall polyethylene tubing conforming to ASHTO M-252 or M-294 may be used where existing tile is rigid conduit (clay or concrete).

FIELD TILE REPAIR



IL-ENG-150

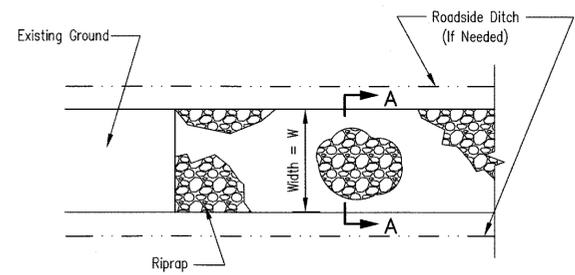

PLAN VIEW

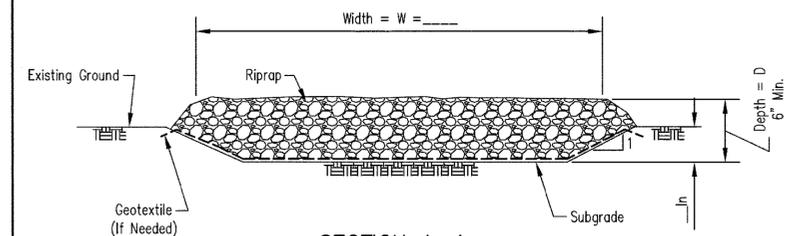

SECTION A-A

- NOTES:
- Rock shall meet one of the following IDOT coarse aggregate gradations, CA-1, CA-2, CA-3 or CA-4 and be placed according to construction specification 25 ROCKFILL using placement Method 1 and Class III compaction.
 - See plans for construction road location, D and W dimensions.
 - Minimum width is 14 feet for one-way traffic and 20 feet for two-way traffic. Two-way traffic widths shall be increased a minimum of 4 feet for trailer traffic. Depending on the type of vehicle or equipment, speed, loads, climatic and other conditions under which vehicles and equipment operate an increase in the minimum widths may be required.
 - Roadway shall follow the contour of the natural terrain to the extent possible.
 - Geotextile (non-woven, needle punched) min. criteria:
 Grab Tensile strength (lb) ASTM D 4632 _____ 202
 Elongation at failure (%) ASTM D 4632 _____ ≥50
 Trapezoidal tear strength (lb) ASTM D 4533 _____ 79
 Puncture strength (lb) ASTM D 6241 _____ 433
 Ultraviolet light (% retained strength) ASTM 4355 _____ min 50
 Apparent opening size (AOS) ASTM D 4751 _____ max 0.22 mm (US sieve size 70)
 Permittivity sec⁻¹/ ASTM D 4491 _____ min 0.70
 - Any geotextile splices shall overlap a minimum of 18 inches, with upstream or upslope geotextile overlapping the abutting downslope geotextile.

CONSTRUCTION ROAD STABILIZATION



IL-ENG-58

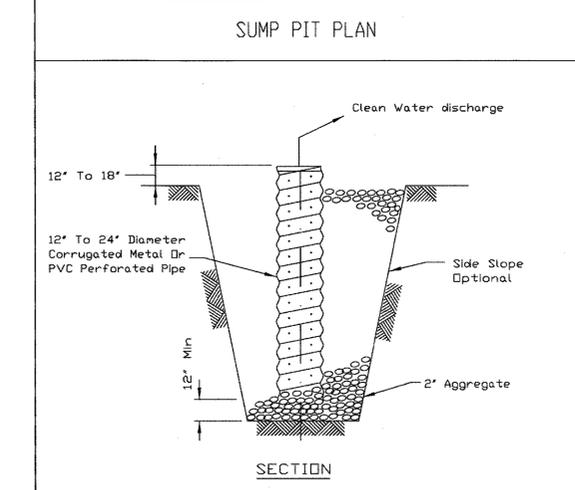

SECTION

- NOTES:
- Pit dimensions are optional.
 - The standpipe will be constructed by perforating a 12'-24' diameter corrugated metal or PVC pipe.
 - A base of 2' aggregate will be placed in the pit to a minimum depth of 12'. After installing the standpipe, the pit surrounding the standpipe will then be backfilled with 2' aggregate.
 - The standpipe will extend 12' to 18' above the lip of the pit.
 - If discharge will be pumped directly to a storm drainage system, the standpipe will be wrapped with filter fabric before installation.
 - If desired, 1/4"-1/2" hardware cloth may be placed around the standpipe prior to attaching the filter fabric. This will increase the rate of water seepage into the pipe.

REFERENCE Project _____ Date _____
 Designed _____ Date _____
 Checked _____ Date _____
 Approved _____ Date _____

STANDARD DVG. NO. IL-650 SHEET 1 OF 1 DATE 8-11-94

FILE NAME = 74754-ahtr.ecad.02.dgn



USER NAME = rjjaeng	DESIGNED - N/A	REVISED -
DRAWN - RGJ	REVISOR -	REVISOR -
CHECKED - RMG	REVISOR -	REVISOR -
DATE - 9/5/2017	REVISOR -	REVISOR -

STATE OF ILLINOIS DEPARTMENT OF TRANSPORTATION

STORMWATER POLLUTION PREVENTION PLAN DETAILS

SCALE: SHEET 2 OF 3 SHEETS STA. TO STA.

F.A.I. RTE. 2298	SECTION 13-00215-30-PV	COUNTY KANE	TOTAL SHEETS 177	SHEET NO. 57
CONTRACT NO. 61D16				ILLINOIS FED. AID PROJECT

ROLLED EROSION CONTROL PRODUCTS

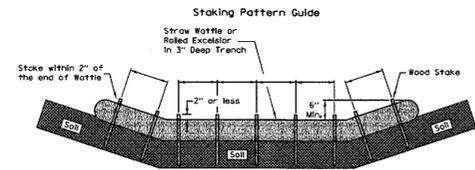

- Notes:**
1. Overlap minimum is the diameter of the roll.
 2. 4" spacing for wattles.
 3. 2" spacing for rolled excelsior.
 4. or space according to manufacturer's specifications.

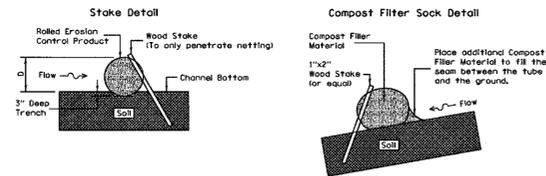

- Notes:**
1. Drawings are not to scale.
 2. Ends of wattles or rolled excelsior shall be turned at least 6" upslope.
 3. Recommended stakes are 1 1/8" wide x 1 1/8" thick x 30" long.
 4. Stakes shall not extend above the straw wattle more than 2".
 5. Spacing: The toe of the upstream ditch check shall create a horizontal line with the top of the downstream ditch check.
 6. When compost filter sock ditch check is used, place a compost berm upstream of the filter sock (see IUM 805). A trench is not required.

REFERENCE	STANDARD DWG. NO.
Project _____	IUM-514
Designed _____	SHEET 1 OF 1
Checked _____	DATE 6-18-11
Approved _____	

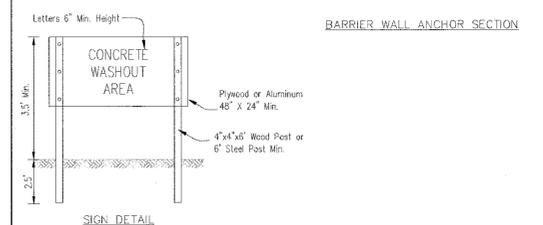
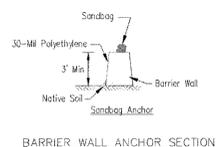
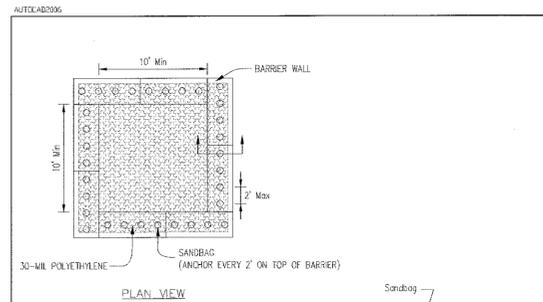

- NOTES:**
1. Maintaining temporary concrete washout facilities shall include removing and disposing of hardened concrete and/or slurry and returning the facilities to a functional condition.
 2. Facility shall be cleaned or reconstructed in a new area once washout becomes two-thirds full.

PROJECT	DESIGNED	CHECKED	APPROVED
DATE	DATE	DATE	DATE
DATE 6-18-11			

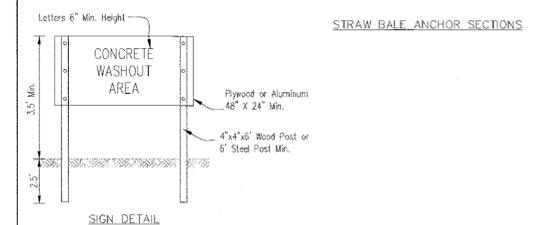
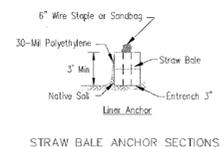
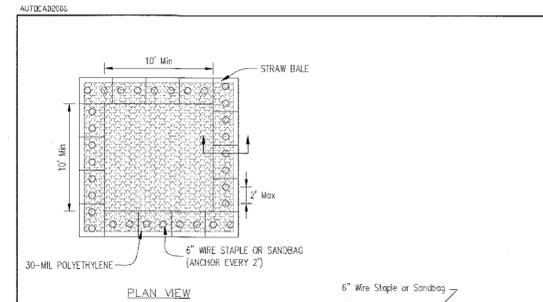

- NOTES:**
1. Maintaining temporary concrete washout facilities shall include removing and disposing of hardened concrete and/or slurry and returning the facilities to a functional condition.
 2. Facility shall be cleaned or reconstructed in a new area once washout becomes two-thirds full.
 3. Each straw bale is to be staked in place using (2) 2"x2"x4" wooden stakes.

PROJECT	DESIGNED	CHECKED	APPROVED
DATE	DATE	DATE	DATE
DATE 6-18-11			

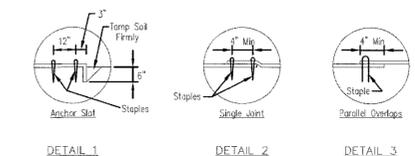
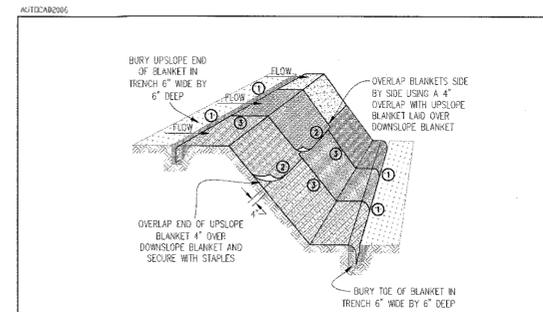

- NOTES:**
1. Staples shall be placed in a diamond pattern of 2 per sq. yd. for stiched blankets. Non-stiched shall use 4 staples per sq. yd. of material. This equates to 200 staples with stiched blanket and 400 staples with non-stiched blanket per 100 sq. yd. of material.
 2. Staple or push pin lengths shall be selected based on soil type and conditions. (minimum staple length is 6")
 3. Erosion control material shall be placed in contact with the soil over a prepared seabed.
 4. All anchor slots shall be stapled at approximately 12" intervals.

PROJECT	DESIGNED	CHECKED	APPROVED
DATE	DATE	DATE	DATE
DATE 6-18-11			

URETHANE FOAM GEOTEXTILES

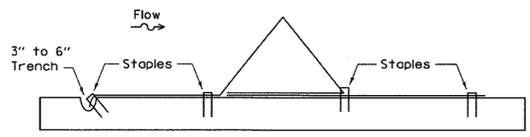
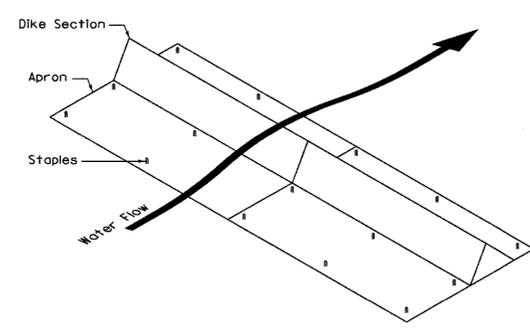

PROJECT	DESIGNED	CHECKED	APPROVED
DATE	DATE	DATE	DATE
DATE 6-30-11			

**INLET PROTECTION - PAVED AREAS
DROP-IN PROTECTION**

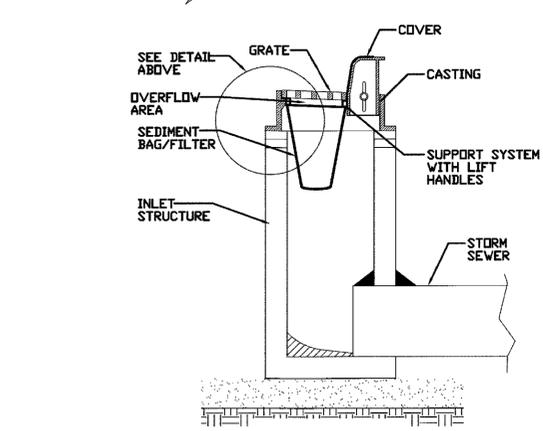
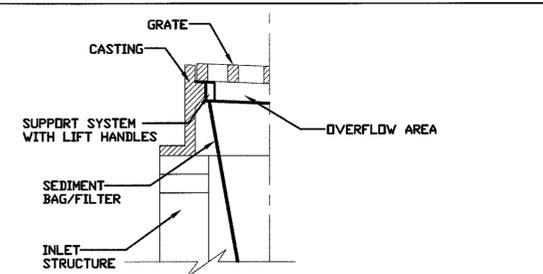

PROJECT	DESIGNED	CHECKED	APPROVED
DATE	DATE	DATE	DATE
DATE 01-11-11			

SILT FENCE PLAN

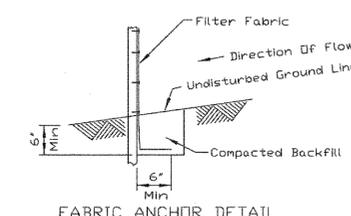
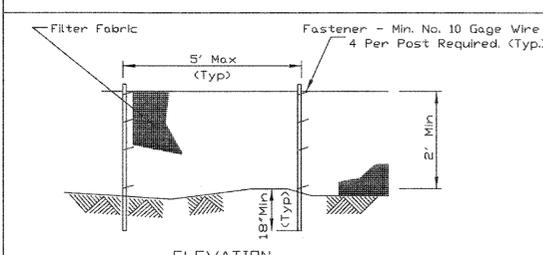

- NOTES:**
1. Temporary sediment fence shall be installed prior to any grading work in the area to be protected. They shall be maintained throughout the construction period and removed in conjunction with the final grading and site stabilization.
 2. Filter fabric shall meet the requirements of material specification S92 Geotextile Table 1 or 2, Class I with equivalent opening size of at least 90 for nonwoven and 50 for woven.
 3. Fence posts shall be either standard steel post or wood post with a minimum cross-sectional area of 3.0 sq. in.

PROJECT	DESIGNED	CHECKED	APPROVED
DATE	DATE	DATE	DATE
DATE 11-20-01			

SILT FENCE

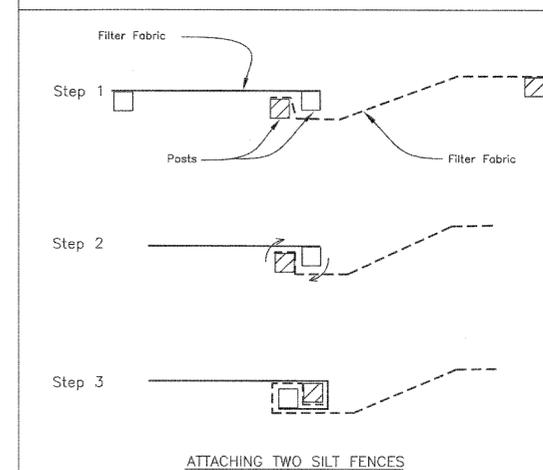

- NOTES:**
1. Place the end post of the second fence inside the end post of the first fence.
 2. Rotate both posts at least 180 degrees in a clockwise direction to create a tight seal with the fabric material.
 3. Drive both posts a minimum of 18 inches into the ground and bury the flap.

PROJECT	DESIGNED	CHECKED	APPROVED
DATE	DATE	DATE	DATE
DATE 1-29-99			

FILE NAME = 74754-shh.ecdetd3.dgn

BURNS MEDONNELL

USER NAME = r.jiang

PLOT SCALE = 2.0000' / in.

PLOT DATE = 9/1/2017

DESIGNED - N/A	REVISED -
DRAWN - RGJ	REVISED -
CHECKED - RMG	REVISED -
DATE - 9/5/2017	REVISED -

**STATE OF ILLINOIS
DEPARTMENT OF TRANSPORTATION**

STORMWATER POLLUTION PREVENTION PLAN DETAILS

SCALE: SHEET 3 OF 3 SHEETS STA. TO STA.

F.A.U. RTE. 2298	SECTION 13-00215-30-PV	COUNTY KANE	TOTAL SHEETS 177	SHEET NO. 58
CONTRACT NO. 61D16				
ILLINOIS FED. AID PROJECT				

DATE: _____
 BY: _____
 SURVEYED _____
 ALIGNED _____
 CHECKED _____
 RT. OF WAY CHECKED _____
 NO. _____
 CAD FILE NAME _____

DATE: _____
 BY: _____
 PROFILE SURVEYED _____
 CHECKED _____
 B.M. NOTED _____
 STRUCTURE NOTATIONS CHKD _____
 NO. _____

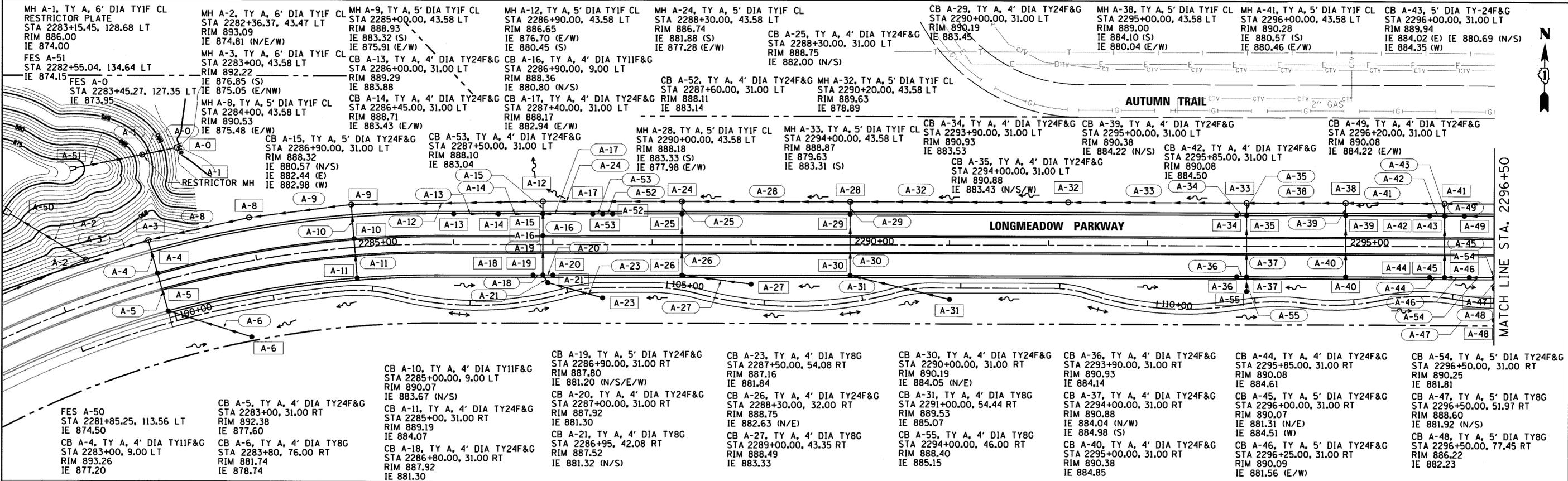

PIPE	DIAMETER (IN)	TYPE	LENGTH (LF)	SLOPE	TRENCH BACKFILL (CY)	PIPE	DIAMETER (IN)	TYPE	LENGTH (LF)	SLOPE	TRENCH BACKFILL (CY)	PIPE	DIAMETER (IN)	TYPE	LENGTH (LF)	SLOPE	TRENCH BACKFILL (CY)	PIPE	DIAMETER (IN)	TYPE	LENGTH (LF)	SLOPE	TRENCH BACKFILL (CY)	PIPE	DIAMETER (IN)	TYPE	LENGTH (LF)	SLOPE	TRENCH BACKFILL (CY)
A-0	42	2	27	0.20%	-	A-12	36	2	194	0.40%	-	A-24	36	2	140	0.40%	-	A-35	18	2	13	1.00%	10.78	A-46	30	2	25	1.00%	30.05
A-1	24	2	73	0.20%	-	A-13	12	2	45	1.00%	16.29	A-25	18	2	13	1.70%	8.41	A-36	12	2	10	1.00%	8.88	A-47	30	2	12	1.00%	7.93
A-2	42	3	89	0.40%	-	A-14	12	2	45	1.00%	15.35	A-26	12	2	62	1.00%	12.03	A-37	12	2	62	1.00%	59.09	A-48	30	2	32	1.00%	1.74
A-3	42	3	67	0.40%	-	A-15	18	2	13	1.00%	4.43	A-27	12	2	71	1.00%	6.43	A-38	36	2	100	0.40%	-	A-49	15	2	20	1.00%	4.26
A-4	24	3	35	1.00%	90.93	A-16	18	2	22	1.00%	5.63	A-28	36	2	170	0.40%	-	A-39	12	2	13	1.00%	4.16	A-52	18	2	10	1.00%	2.56
A-5	24	3	40	1.00%	103.92	A-17	12	2	50	1.00%	17.05	A-29	15	2	13	1.00%	2.67	A-40	12	2	62	1.00%	23.75	A-53	18	2	10	1.00%	2.56
A-6	24	3	88	1.30%	5.36	A-18	12	2	10	1.00%	2.36	A-30	12	2	62	1.00%	17.24	A-41	36	2	100	0.40%	-	A-54	30	2	25	1.00%	23.18
A-8	36	2	105	0.40%	-	A-19	18	2	40	1.00%	11.24	A-31	12	2	103	1.00%	9.46	A-42	12	2	15	1.00%	3.54	A-55	12	2	17	1.00%	4.01
A-9	36	3	105	0.40%	-	A-20	12	2	10	1.00%	2.36	A-32	36	2	220	0.40%	-	A-43	30	2	13	1.00%	15.63						
A-10	15	3	35	1.00%	26.08	A-21	15	2	10	2.10%	2.13	A-33	36	2	180	0.40%	-	A-44	12	2	15	1.00%	9.48						
A-11	12	2	40	1.00%	14.48	A-23	12	2	57	1.00%	3.80	A-34	12	2	10	1.00%	9.85	A-45	30	2	62	1.00%	80.10						

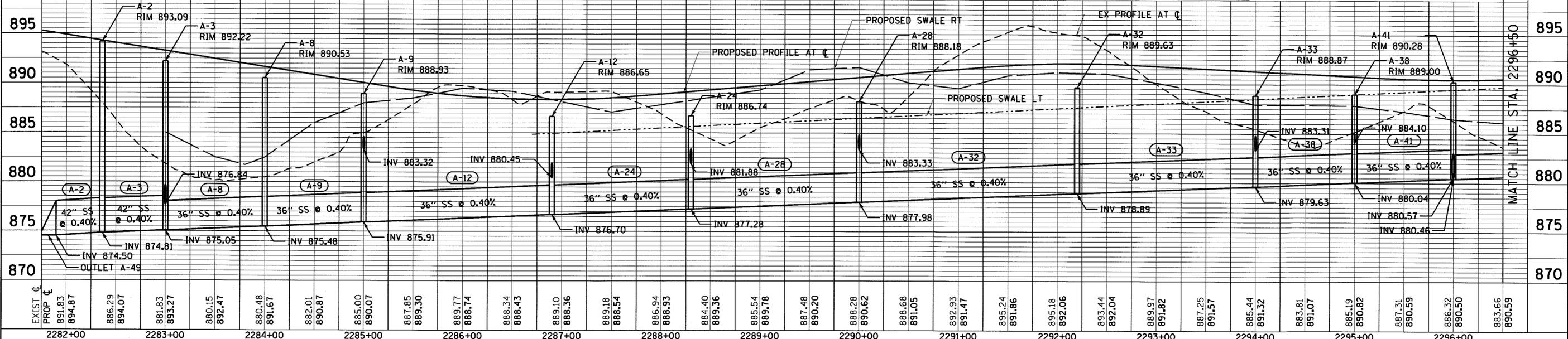

EXIST. CL	PROP. CL	2282+00	2283+00	2284+00	2285+00	2286+00	2287+00	2288+00	2289+00	2290+00	2291+00	2292+00	2293+00	2294+00	2295+00	2296+00																																											
894.87	894.87	886.29	894.07	881.83	893.27	880.15	892.47	880.48	891.67	882.01	890.87	885.00	890.07	887.85	889.30	889.77	888.74	888.34	888.43	889.10	888.36	889.18	888.54	886.94	888.93	884.40	889.36	885.54	889.78	887.48	890.20	888.28	890.62	888.68	891.05	892.93	891.47	895.24	891.86	895.18	892.06	893.44	892.04	889.97	891.82	887.25	891.57	885.44	891.32	883.81	891.07	885.19	890.82	887.31	890.59	886.32	890.50	883.66	890.59

BURNS & MCDONNELL

USER NAME = r.jiang
 DESIGNED - CFZ
 DRAWN - RGJ
 CHECKED - RMG
 DATE - 9/5/2017

REVISED -
 REVISED -
 REVISED -
 REVISED -

STATE OF ILLINOIS
DEPARTMENT OF TRANSPORTATION

DRAINAGE AND UTILITIES PLAN AND PROFILE
 SECTION 13-00215-30-PV
 COUNTY KANE
 TOTAL SHEETS 177
 SHEET NO. 59
 CONTRACT NO. 61D16
 ILLINOIS FED. AID PROJECT

SCALE: 1" = 50'
 SHEET 1 OF 5 SHEETS
 STA. 2283+00.00 TO STA. 2296+50.00

DATE	
BY	
REVISIONS	
NO.	
DATE	
BY	
REVISIONS	
NO.	
DATE	
BY	
REVISIONS	
NO.	

DATE	
BY	
REVISIONS	
NO.	
DATE	
BY	
REVISIONS	
NO.	

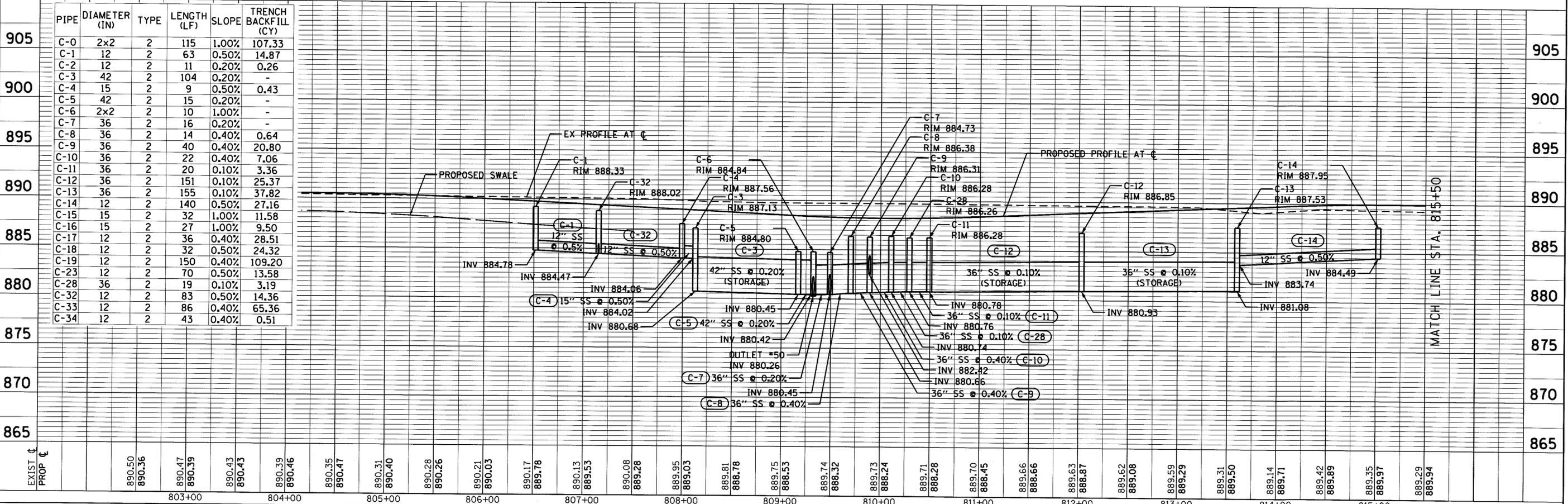
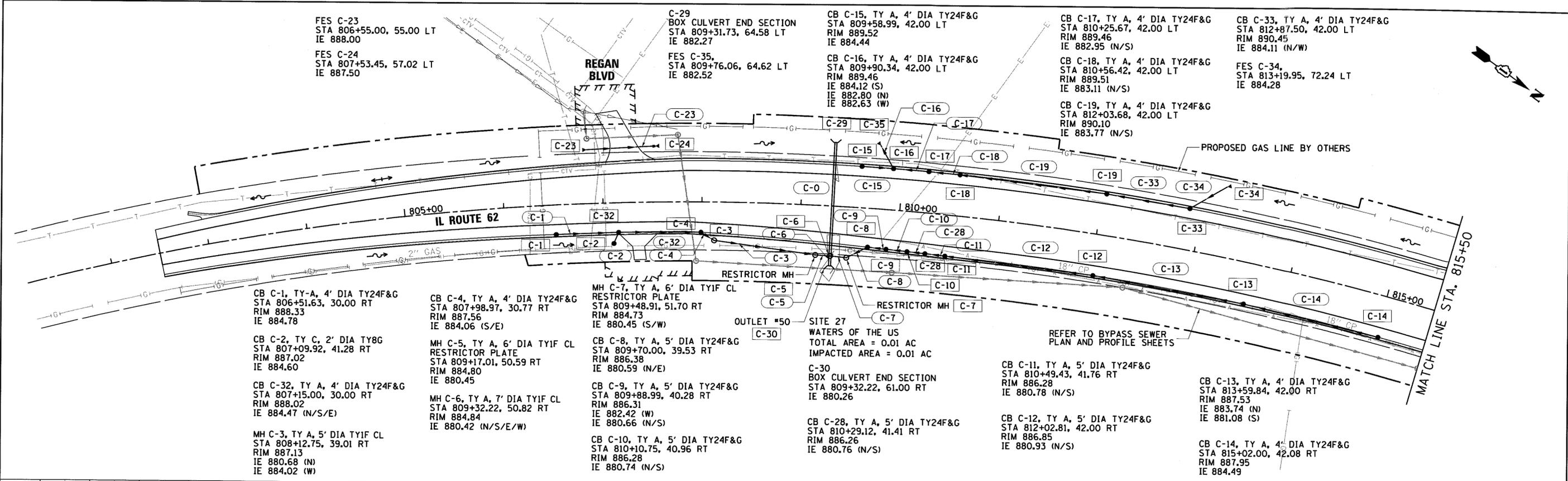

	USER NAME = r.jiang PLOT SCALE = 1/8" = 100.0000' / 1" / 16" PLOT DATE = 9/11/2017	DESIGNED - CFZ DRAWN - RGJ CHECKED - RMG DATE - 9/5/2017	REVISED - REVISED - REVISED - REVISED -	STATE OF ILLINOIS DEPARTMENT OF TRANSPORTATION	DRAINAGE AND UTILITIES PLAN AND PROFILE (NB PROFILE) SCALE: 1" = 50' SHEET 3 OF 5 SHEETS STA. 802+50.00 TO STA. 815+50.00	F.A.U. RTE. 2298 SECTION 13-00215-30-PV COUNTY KANE TOTAL SHEETS 177 SHEET NO. 61 CONTRACT NO. 61D16 ILLINOIS FED. AID PROJECT
--	------------------------------------------------------------------------------------------	-------------------------------------------------------------------	--------------------------------------------------	-----------------------------------------------------------------	-------------------------------------------------------------------------------------------------------------------------------------------	--------------------------------------------------------------------------------------------------------------------------------------------------

DATE	
BY	
PLANNED	
DESIGNED	
CHECKED	
NOTED	
NO.	

DATE	
BY	
PROFILING	
GRADES CHECKED	
STRUCTURE NOTATIONS CHECKED	
NO.	

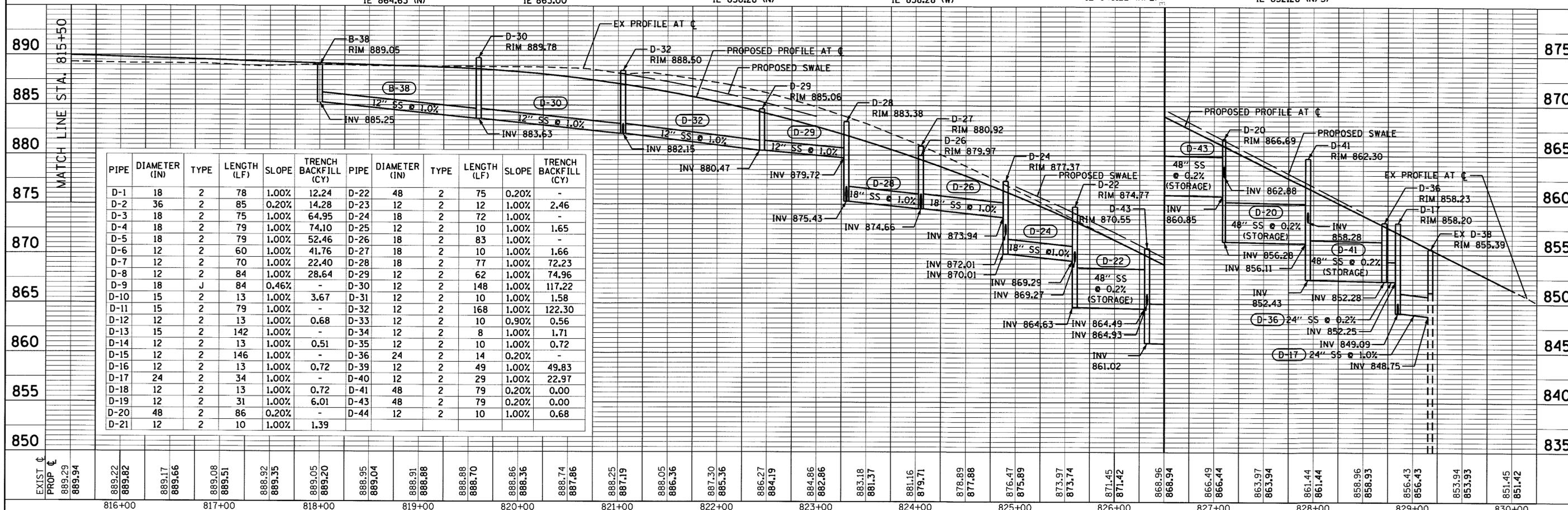
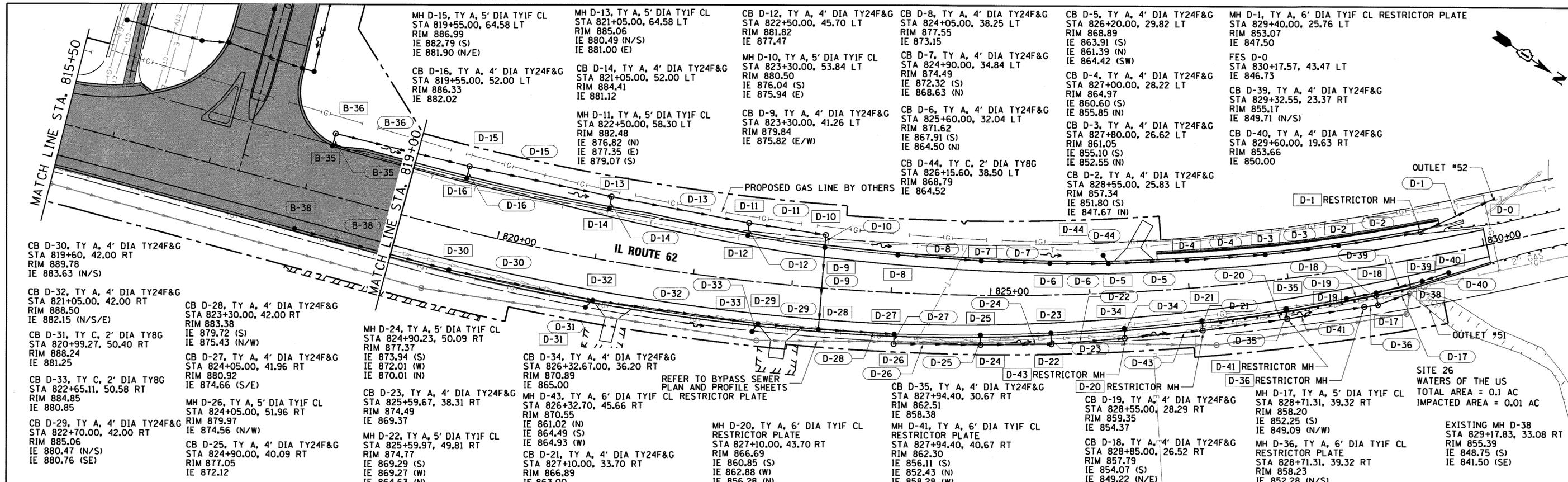

PLAN	SURVEYED	BY	DATE
	PLOTTED		
	CHECKED		
	BY		
	NO. OF WAYS CHECKED		
	CADD FILE NAME		
	NO.		

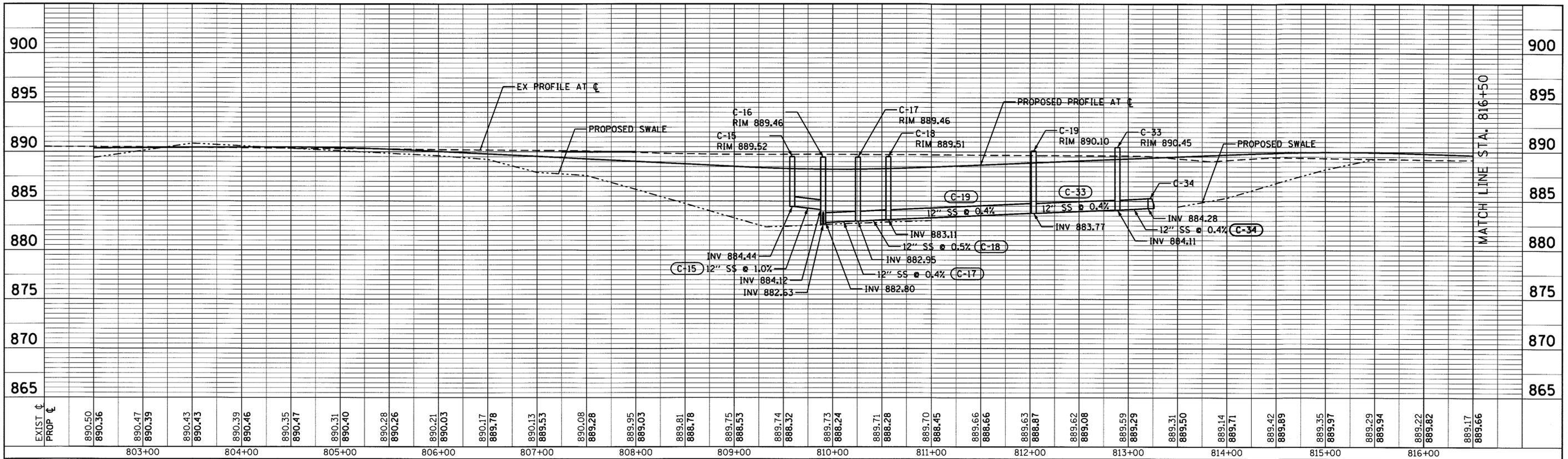

PROFILE	SURVEYED	BY	DATE
	PLOTTED		
	CHECKED		
	BY		
	NO. OF WAYS CHECKED		
	STRUCTURE NOTATION CHFD		
	NO.		

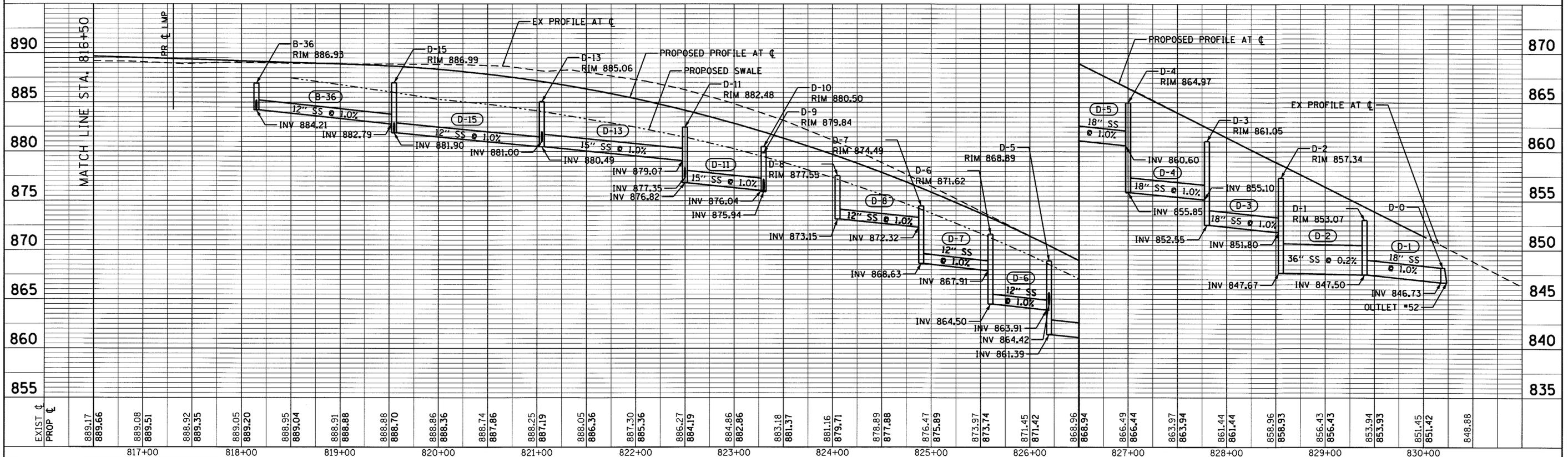

USER NAME = r.jiang
 PLOT SCALE = 1/80000
 PLOT DATE = 9/1/2017

DESIGNED - CFZ
 DRAWN - RGJ
 CHECKED - RMG
 DATE

REVISED -
 REVISED -
 REVISED -
 REVISED -

STATE OF ILLINOIS
 DEPARTMENT OF TRANSPORTATION

DRAINAGE AND UTILITIES PLAN AND PROFILE (SB PROFILE)

SCALE: 1" = 50' SHEET 5 OF 5 SHEETS STA. 802+50.00 TO STA. 830+02.95

F.A.U. RTE.	SECTION	COUNTY	TOTAL SHEETS	SHEET NO.
2298	13-00215-30-PV	KANE	177	63
ILLINOIS FED. AID PROJECT			CONTRACT NO. 61D16	

PIPE	DIAMETER (IN)	TYPE	LENGTH (LF)	SLOPE	TRENCH BACKFILL (CY)
E-1	18	2	28	3.57%	-
E-2	18	2	93	1.15%	42.36
E-4	18	J	130	1.16%	-
E-5	18	2	198	0.25%	-
E-6	18	2	233	0.25%	-
E-7	18	2	309	0.25%	-



PLAN	SURVEYED	DATE
	PLOTTED	
	CHECKED	
	BY	
	NO.	

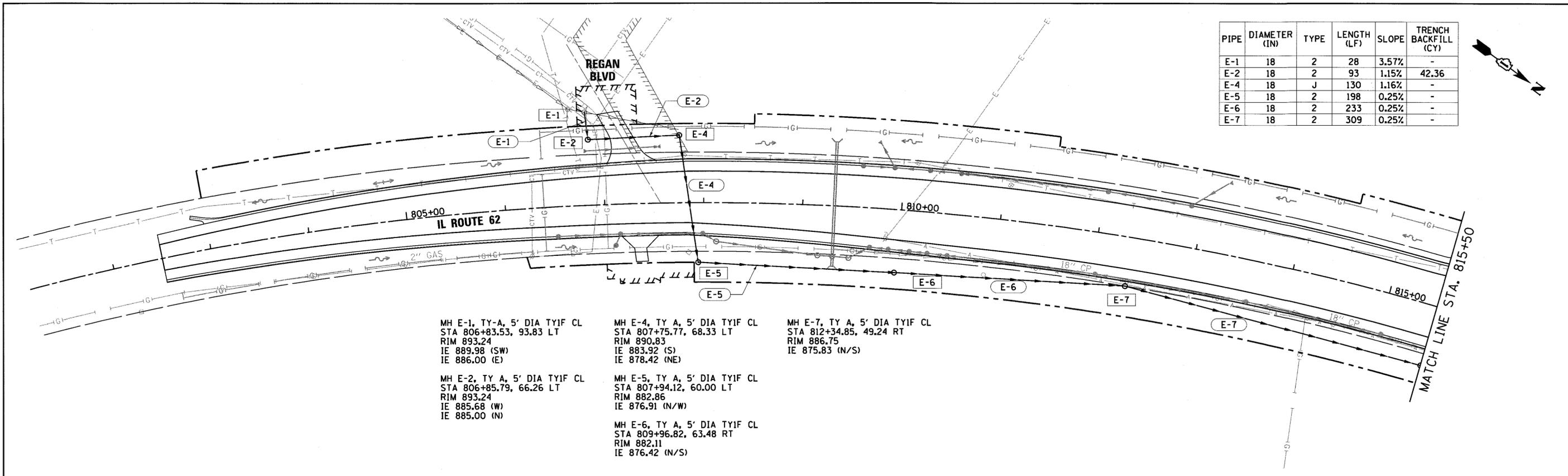

MH E-1, TY-A, 5' DIA TYIF CL
 STA 806+83.53, 93.83 LT
 RIM 893.24
 IE 889.98 (SW)
 IE 886.00 (E)

MH E-2, TY A, 5' DIA TYIF CL
 STA 806+85.79, 66.26 LT
 RIM 893.24
 IE 885.68 (W)
 IE 885.00 (N)

MH E-4, TY A, 5' DIA TYIF CL
 STA 807+75.77, 68.33 LT
 RIM 890.83
 IE 883.92 (S)
 IE 876.42 (NE)

MH E-5, TY A, 5' DIA TYIF CL
 STA 807+94.12, 60.00 LT
 RIM 882.86
 IE 876.91 (N/W)

MH E-6, TY A, 5' DIA TYIF CL
 STA 809+96.82, 63.48 RT
 RIM 882.11
 IE 876.42 (N/S)

MH E-7, TY A, 5' DIA TYIF CL
 STA 812+34.85, 49.24 RT
 RIM 886.75
 IE 875.83 (N/S)

PROFILE	SURVEYED	DATE
	PLOTTED	
	CHECKED	
	BY	
	NO.	

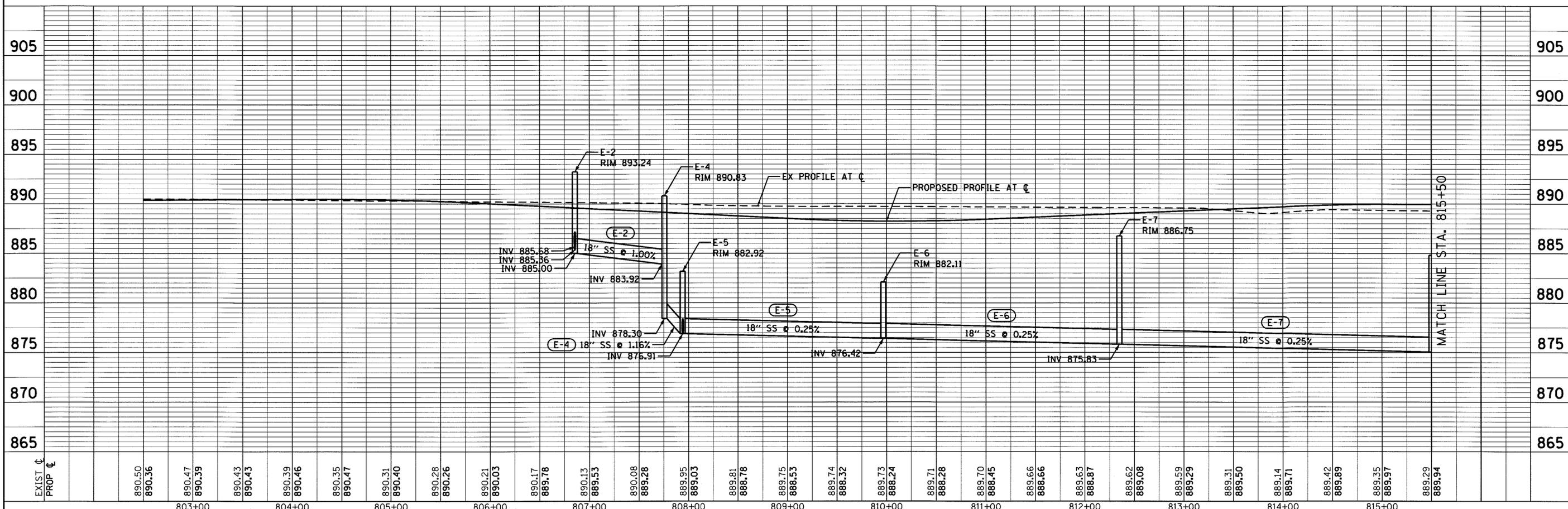

EXISTING PROFILE	PROPOSED PROFILE	STATION	ELEVATION
890.50	890.36	803+00	
890.47	890.39	804+00	
890.43	890.43	805+00	
890.39	890.46	806+00	
890.35	890.47	807+00	
890.31	890.40	808+00	
890.28	890.26	809+00	
890.21	890.03	810+00	
890.17	889.78	811+00	
890.13	889.53	812+00	
890.08	889.28	813+00	
889.95	889.03	814+00	
889.81	888.78	815+00	
889.75	888.53	816+00	
889.74	888.32	817+00	
889.73	888.24	818+00	
889.71	888.28	819+00	
889.70	888.45	820+00	
889.66	888.66	821+00	
889.63	888.87	822+00	
889.62	889.08	823+00	
889.59	889.29	824+00	
889.31	889.50	825+00	
889.14	889.71	826+00	
889.42	889.89	827+00	
889.35	889.97	828+00	
889.29	889.94	829+00	



USER NAME = rjhang	DESIGNED - CFZ	REVISED -
PLLOT SCALE = 1/8" = 1'-0"	DRAWN - RGJ	REVISED -
PLLOT DATE = 9/1/2017	CHECKED - RMG	REVISED -
	DATE - 9/5/2017	REVISED -

STATE OF ILLINOIS
 DEPARTMENT OF TRANSPORTATION

BYPASS SEWER PLAN AND PROFILE
 SCALE: 1" = 50'
 SHEET 1 OF 2 SHEETS
 STA. 802+50.00 TO STA. 815+50.00

F.A.U. RTE. 2298	SECTION 13-00215-30-PV	COUNTY KANE	TOTAL SHEETS 177	SHEET NO. 64
CONTRACT NO. 61D16			ILLINOIS FED. AID PROJECT	

PLAN SURVEYED BY DATE
 PLOTTED BY DATE
 NOTE BOOK NO. _____
 RT. OF WAY CHECKED BY _____
 NO. _____ CADD FILE NAME _____

PROFILE SURVEYED BY DATE
 PLOTTED BY DATE
 NOTE BOOK NO. _____
 RT. OF WAY CHECKED BY _____
 NO. _____ STRUCTURE NOTATIONS CHFD _____

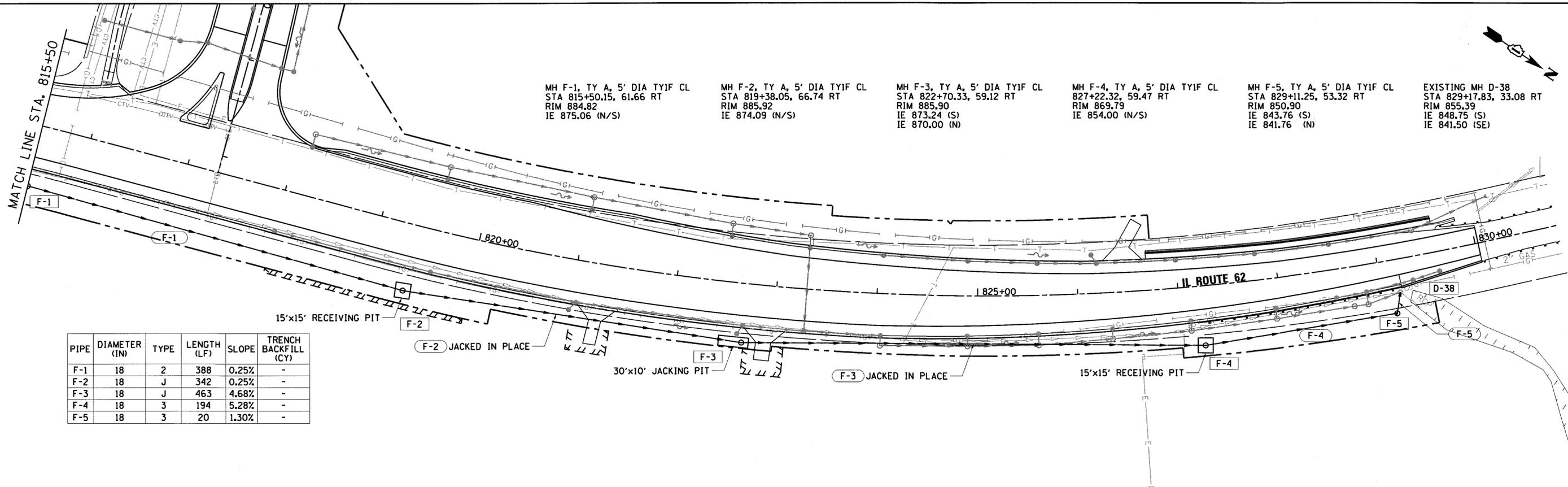

MH F-1, TY A, 5' DIA TYIF CL
 STA 815+50.15, 61.66 RT
 RIM 884.82
 IE 875.06 (N/S)

MH F-2, TY A, 5' DIA TYIF CL
 STA 819+38.05, 66.74 RT
 RIM 885.92
 IE 874.09 (N/S)

MH F-3, TY A, 5' DIA TYIF CL
 STA 822+70.33, 59.12 RT
 RIM 885.90
 IE 873.24 (S)
 IE 870.00 (N)

MH F-4, TY A, 5' DIA TYIF CL
 STA 827+22.32, 59.47 RT
 RIM 869.79
 IE 854.00 (N/S)

MH F-5, TY A, 5' DIA TYIF CL
 STA 829+11.25, 53.32 RT
 RIM 850.90
 IE 843.76 (S)
 IE 841.76 (N)

EXISTING MH D-38
 STA 829+17.83, 33.08 RT
 RIM 855.39
 IE 848.75 (S)
 IE 841.50 (SE)

PIPE	DIAMETER (IN)	TYPE	LENGTH (LF)	SLOPE	TRENCH BACKFILL (CY)
F-1	18	2	388	0.25%	-
F-2	18	J	342	0.25%	-
F-3	18	J	463	4.68%	-
F-4	18	3	194	5.28%	-
F-5	18	3	20	1.30%	-

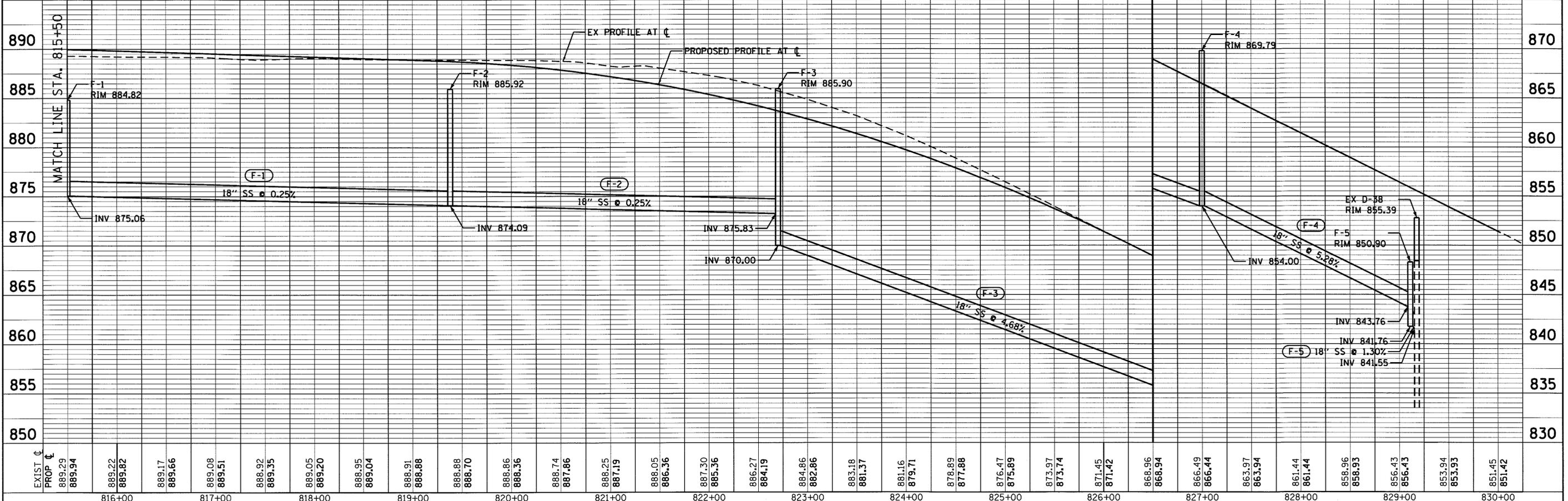

EXIST	PROP	816+00	817+00	818+00	819+00	820+00	821+00	822+00	823+00	824+00	825+00	826+00	827+00	828+00	829+00	830+00																																									
889.29	889.17	889.22	889.17	889.08	889.51	888.52	889.35	889.05	889.20	888.95	889.04	888.91	888.88	888.88	888.70	888.66	888.36	888.74	887.86	888.25	887.19	888.05	886.36	887.30	885.36	886.27	884.19	884.86	882.86	883.18	881.37	881.16	879.71	878.89	877.88	876.47	875.89	873.97	873.74	871.45	871.42	868.96	868.94	866.49	866.44	863.97	863.94	861.44	861.44	858.96	858.93	856.43	856.43	853.94	853.93	851.45	851.42



USER NAME = rjlang
 DESIGNED - CFZ
 DRAWN - RGJ
 CHECKED - RMG
 DATE - 9/5/2017

REVISED -
 REVISED -
 REVISED -
 REVISED -

STATE OF ILLINOIS
 DEPARTMENT OF TRANSPORTATION

BYPASS SEWER PLAN AND PROFILE
 SCALE: 1" = 50'
 SHEET 2 OF 2 SHEETS
 STA. 815+50.00 TO STA. 830+02.95

F.A.U. RTE. 2298
 SECTION 13-00215-30-PV
 COUNTY KANE
 TOTAL SHEETS 177
 SHEET NO. 65
 CONTRACT NO. 61D16
 ILLINOIS FED. AID PROJECT

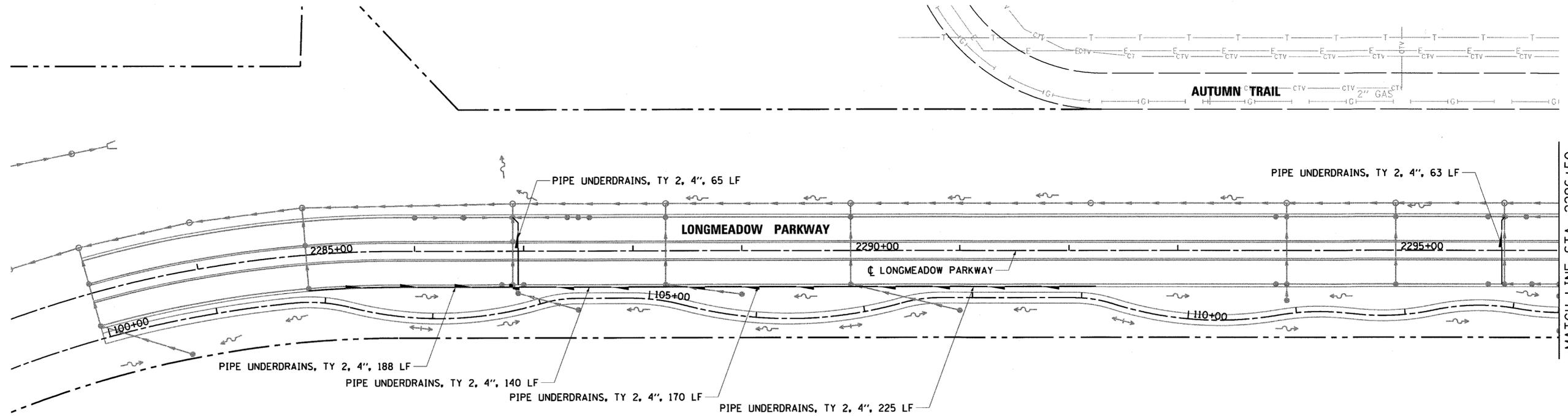

STRUCTURE	FROM STATION	OFFSET	TO STRUCTURE	STATION	OFFSET	PIPE UNDERDRAIN, TYPE 2, 4" (FT) 60108204
A-11	2285+00.00	RT	A-19	2286+90.00	RT	188
A-19	2286+90.00	RT	A-15	2286+90.00	LT	65
A-26	2288+30.00	RT	A-19	2286+90.00	RT	140
A-30	2290+00.00	RT	A-26	2288+30.00	RT	170
	2292+25.0	RT	A-19	2286+90.00	RT	225
A-45	2296+00.00	RT	A-43	2296+00.00	LT	63

STRUCTURE	FROM STATION	OFFSET	TO STRUCTURE	STATION	OFFSET	PIPE UNDERDRAIN, TYPE 2, 4" (FT) 60108204
	2298+75.0	RT	B-5	2299+60.00	RT	87
B-5	2299+60.00	RT	B-4	2299+60.00	LT	81
	2301+98.0	RT	B-5	2299+60.00	RT	242
	2301+00.0	LT	B-13	2301+00.00	LT	100
B-13	2301+00.00	LT	B-17	2303+00.00	LT	196
	2301+98.0	RT	B-19	2303+00.00	RT	105
B-19	2303+00.00	RT	B-32	2305+95.00	RT	302
B-18	2303+00.00	LT	B-23	2304+95.00	LT	157
	2304+95.0	RT	B-23	2304+95.00	LT	77
B-25	2305+05.00	LT	B-23	2304+95.00	LT	54
B-31	2306+00.00	LT	B-25	2305+05.00	LT	85
B-35	2306+67.67	LT	B-31	2306+00.00	LT	90
	2306+56.8	RT	B-32	2305+95.00	RT	109
B-38	818+00.00	RT	C-14	815+02.00	RT	297
D-30	819+60.00	RT	B-38	818+00.00	RT	161

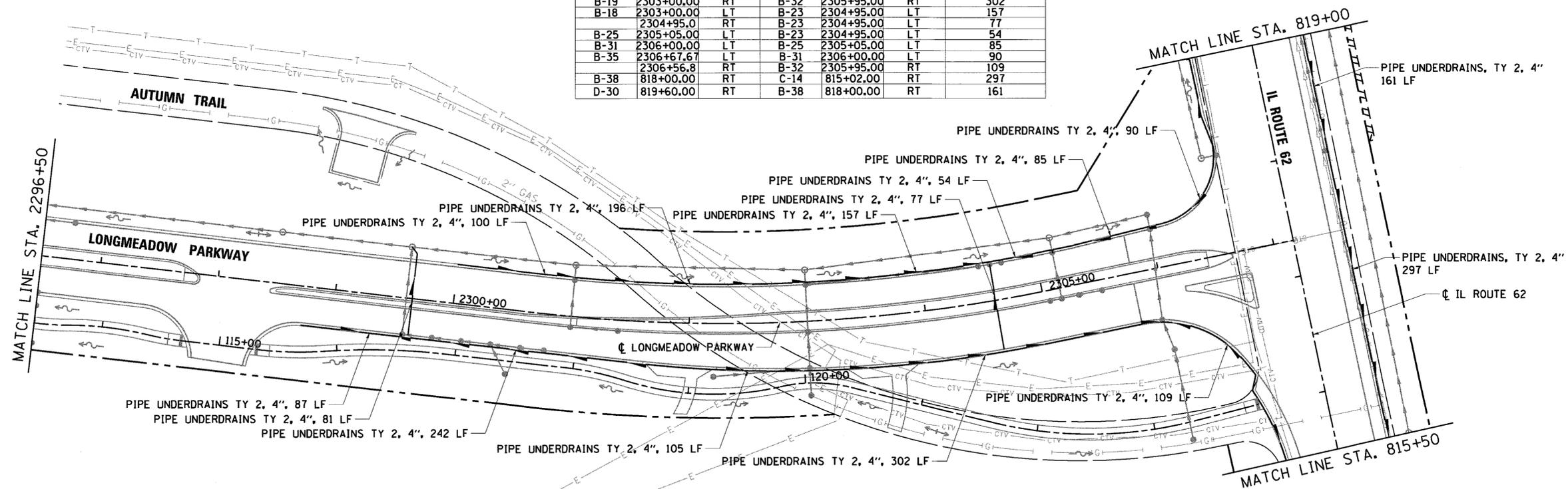

FILE NAME = 74754-shr-underdrain01.dgn

BURNS MCDONNELL	USER NAME = rjiang	DESIGNED - CFZ	REVISED -	STATE OF ILLINOIS DEPARTMENT OF TRANSPORTATION	UNDERDRAIN PLAN	F.A.U. RTE. 2298	SECTION 13-00215-30-PV	COUNTY KANE	TOTAL SHEETS 177	SHEET NO. 66
	PLOT SCALE = 1/8" = 100'-0"	CHECKED - RMG	REVISOR -			SCALE: 1" = 50'	SHEET 1 OF 2 SHEETS	STA. 2283+00.00 TO STA. 2307+16.89	CONTRACT NO. 61D16 ILLINOIS FED. AID PROJECT	
	PLOT DATE = 9/1/2017	DATE - 9/5/2017	REVISOR -							

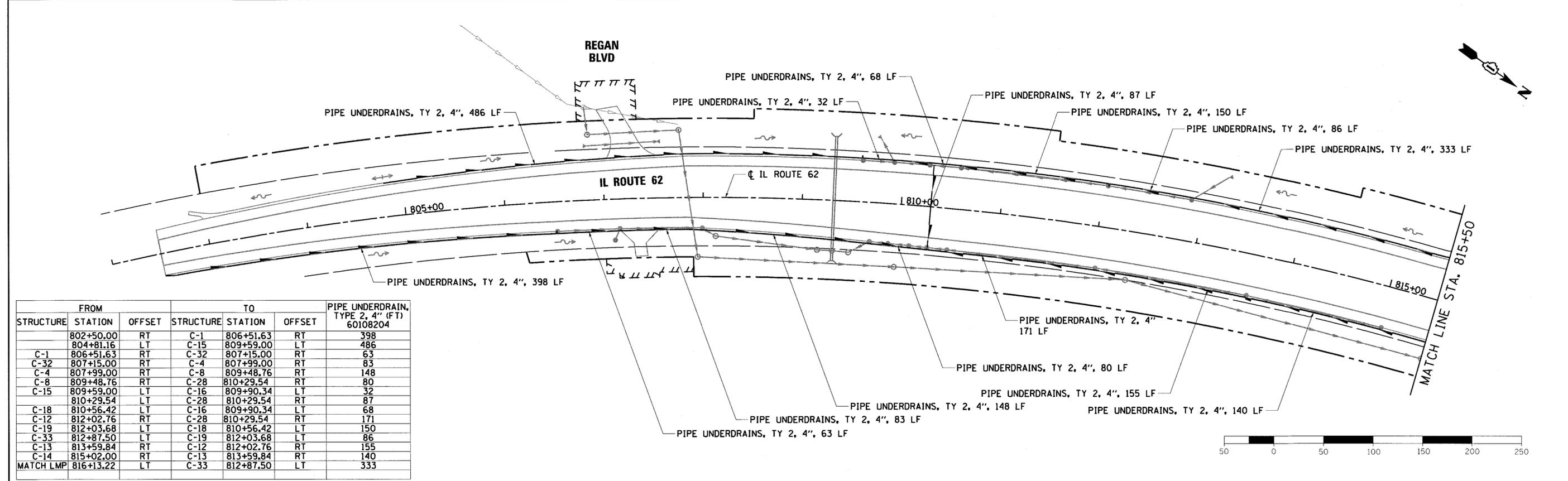

STRUCTURE	FROM STATION	OFFSET	TO STRUCTURE	STATION	OFFSET	PIPE UNDERDRAIN, TYPE 2, 4" (FT) 60108204
	802+50.00	RT	C-1	806+51.63	RT	398
	804+81.16	LT	C-15	809+59.00	LT	486
C-1	806+51.63	RT	C-32	807+15.00	RT	63
C-32	807+15.00	RT	C-4	807+99.00	RT	83
C-4	807+99.00	RT	C-8	809+48.76	RT	148
C-8	809+48.76	RT	C-28	810+29.54	RT	80
C-15	809+59.00	LT	C-16	809+90.34	LT	32
	810+29.54	LT	C-28	810+29.54	RT	87
C-18	810+56.42	LT	C-16	809+90.34	LT	68
C-12	812+02.76	RT	C-28	810+29.54	RT	171
C-19	812+03.68	LT	C-18	810+56.42	LT	150
C-33	812+87.50	LT	C-19	812+03.68	LT	86
C-13	813+59.84	RT	C-12	812+02.76	RT	155
C-14	815+02.00	RT	C-13	813+59.84	RT	140
MATCH LMP	816+13.22	LT	C-33	812+87.50	LT	333

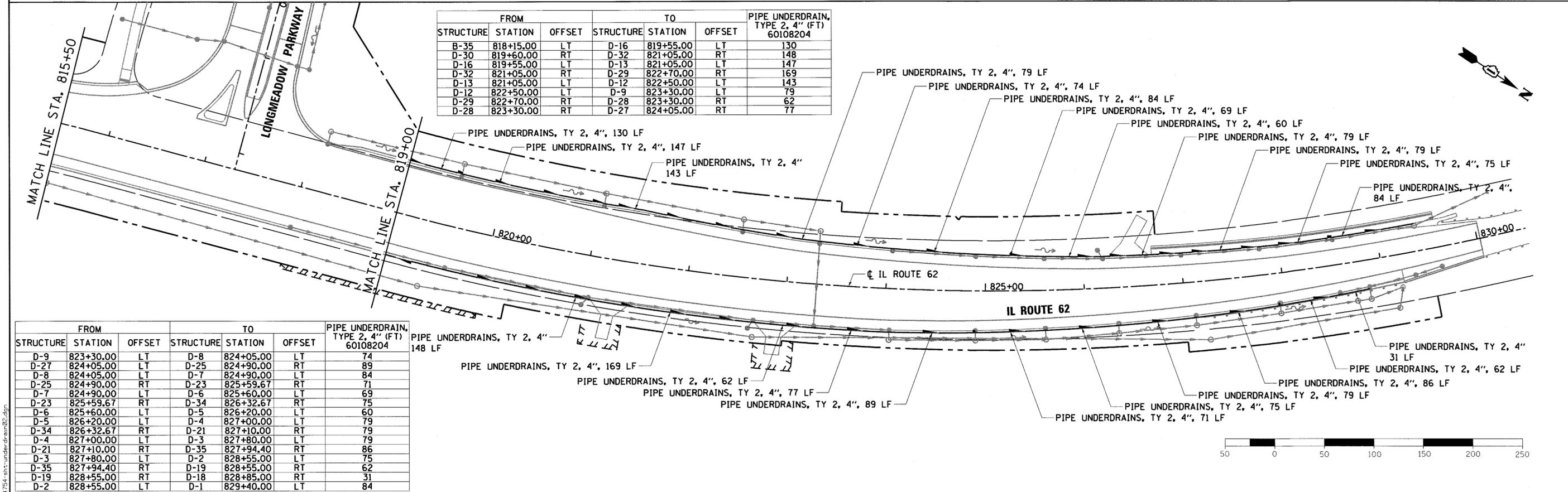

STRUCTURE	FROM STATION	OFFSET	TO STRUCTURE	STATION	OFFSET	PIPE UNDERDRAIN, TYPE 2, 4" (FT) 60108204
B-35	818+15.00	LT	D-16	819+55.00	LT	130
D-30	819+60.00	RT	D-32	821+05.00	RT	148
D-16	819+55.00	LT	D-13	821+05.00	LT	147
D-32	821+05.00	RT	D-29	822+70.00	RT	169
D-13	821+05.00	LT	D-12	822+50.00	LT	143
D-12	822+50.00	LT	D-9	823+30.00	LT	79
D-29	822+70.00	RT	D-28	823+30.00	RT	62
D-28	823+30.00	RT	D-27	824+05.00	RT	77

STRUCTURE	FROM STATION	OFFSET	TO STRUCTURE	STATION	OFFSET	PIPE UNDERDRAIN, TYPE 2, 4" (FT) 60108204
D-9	823+30.00	LT	D-8	824+05.00	LT	74
D-27	824+05.00	LT	D-25	824+90.00	RT	89
D-8	824+05.00	LT	D-7	824+90.00	LT	84
D-25	824+90.00	RT	D-23	825+59.67	RT	71
D-7	824+90.00	LT	D-6	825+60.00	LT	69
D-23	825+59.67	RT	D-34	826+32.67	RT	75
D-6	825+60.00	LT	D-5	826+20.00	LT	60
D-5	826+20.00	LT	D-4	827+00.00	LT	79
D-34	826+32.67	RT	D-21	827+10.00	RT	79
D-4	827+00.00	LT	D-3	827+80.00	LT	79
D-21	827+10.00	RT	D-35	827+94.40	RT	86
D-3	827+80.00	LT	D-2	828+55.00	LT	75
D-35	827+94.40	RT	D-19	828+55.00	RT	62
D-19	828+55.00	RT	D-18	828+85.00	RT	31
D-2	828+55.00	LT	D-1	829+40.00	LT	84

FILE NAME = 74754-shr-underdrain02.dgn

STORM SEWER E-4 JACKING DETAIL
STA 807+85.32

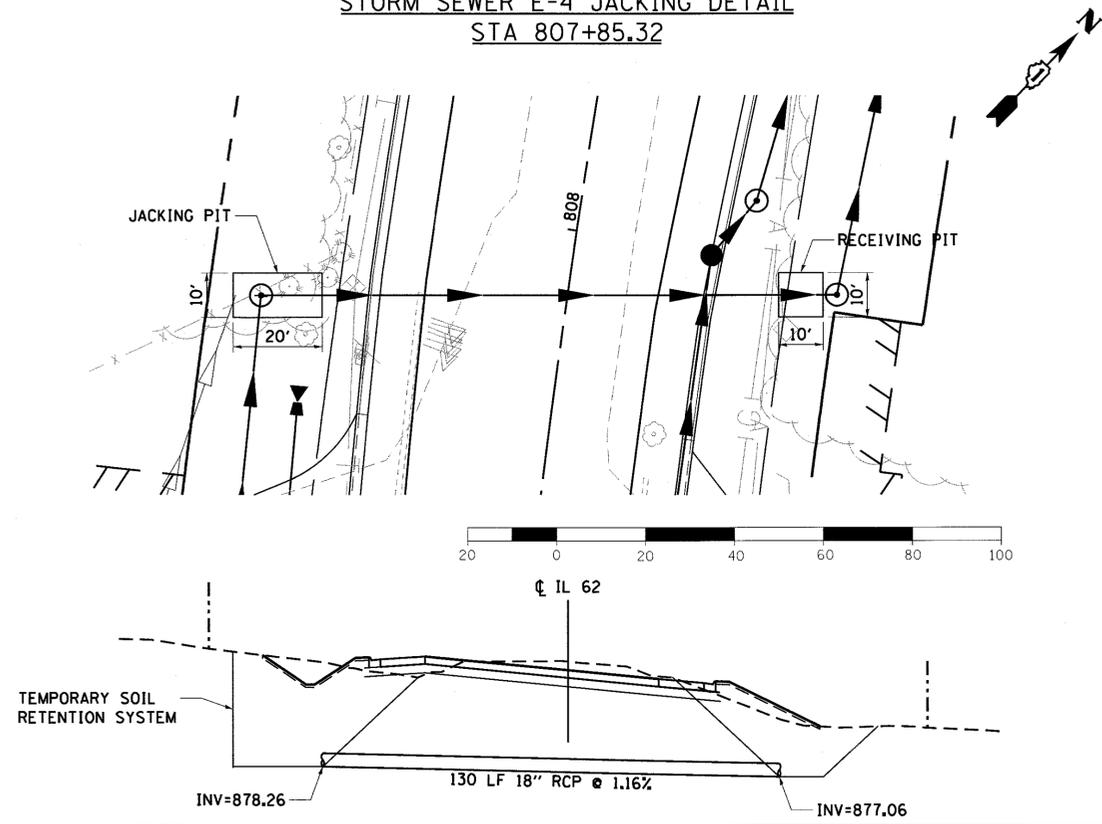

STORM SEWER D-9 JACKING DETAIL
STA 823+30.00

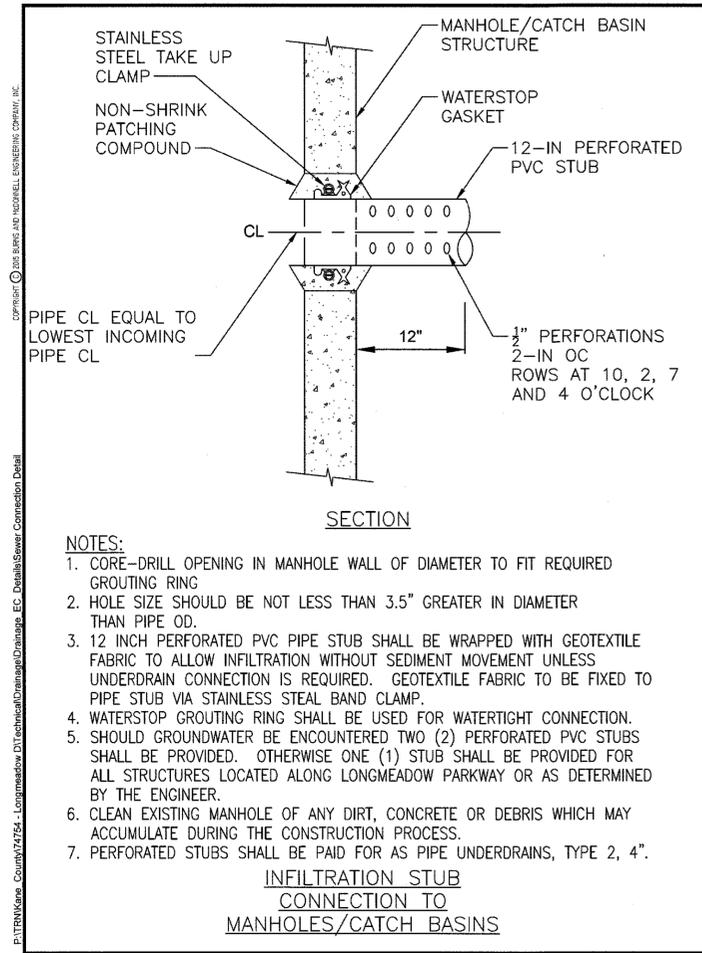
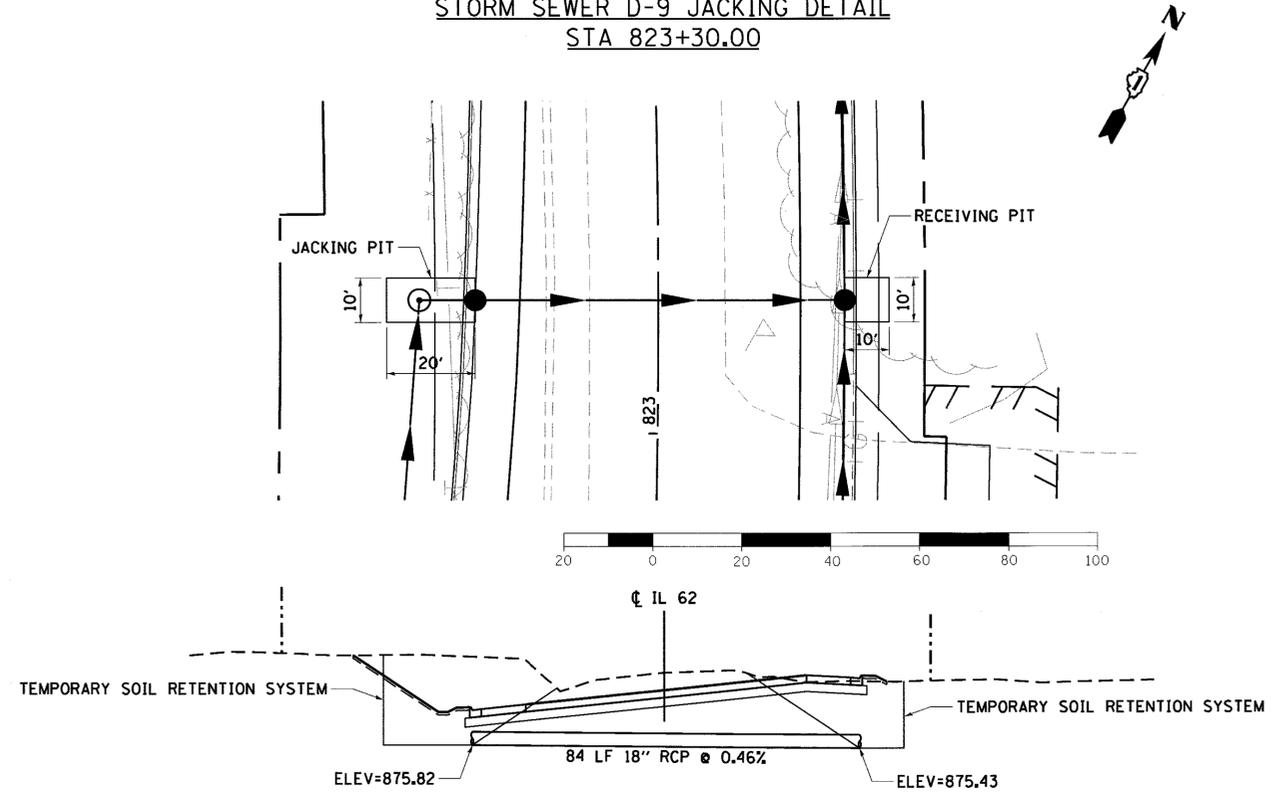

- NOTES:
1. CORE-DRILL OPENING IN MANHOLE WALL OF DIAMETER TO FIT REQUIRED GROUTING RING
 2. HOLE SIZE SHOULD BE NOT LESS THAN 3.5" GREATER IN DIAMETER THAN PIPE OD.
 3. 12 INCH PERFORATED PVC PIPE STUB SHALL BE WRAPPED WITH GEOTEXTILE FABRIC TO ALLOW INFILTRATION WITHOUT SEDIMENT MOVEMENT UNLESS UNDERDRAIN CONNECTION IS REQUIRED. GEOTEXTILE FABRIC TO BE FIXED TO PIPE STUB VIA STAINLESS STEEL BAND CLAMP.
 4. WATERSTOP GROUTING RING SHALL BE USED FOR WATERTIGHT CONNECTION.
 5. SHOULD GROUNDWATER BE ENCOUNTERED TWO (2) PERFORATED PVC STUBS SHALL BE PROVIDED. OTHERWISE ONE (1) STUB SHALL BE PROVIDED FOR ALL STRUCTURES LOCATED ALONG LONGMEADOW PARKWAY OR AS DETERMINED BY THE ENGINEER.
 6. CLEAN EXISTING MANHOLE OF ANY DIRT, CONCRETE OR DEBRIS WHICH MAY ACCUMULATE DURING THE CONSTRUCTION PROCESS.
 7. PERFORATED STUBS SHALL BE PAID FOR AS PIPE UNDERDRAINS, TYPE 2, 4".

INFILTRATION STUB
CONNECTION TO
MANHOLES/CATCH BASINS

FILE NAME = 74754-ahs-drain-ds30.dgn



USER NAME = r.jiang	DESIGNED - CFZ	REVISED -
PLOT SCALE = 40.0000' / in.	DRAWN - RGJ	REVISED -
PLOT DATE = 9/1/2017	CHECKED - RMG	REVISED -
	DATE - 9/5/2017	REVISED -

STATE OF ILLINOIS
DEPARTMENT OF TRANSPORTATION

DRAINAGE DETAILS				
SCALE:	SHEET	OF	SHEETS	STA. TO STA.

F.A.U. RTE.	SECTION	COUNTY	TOTAL SHEETS	SHEET NO.
2298	13-00215-30-PV	KANE	177	68
CONTRACT NO. 61D16				
ILLINOIS FED. AID PROJECT				

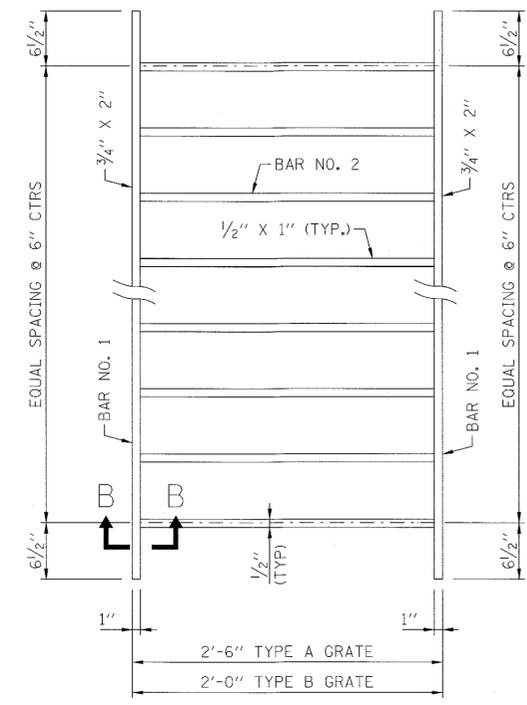
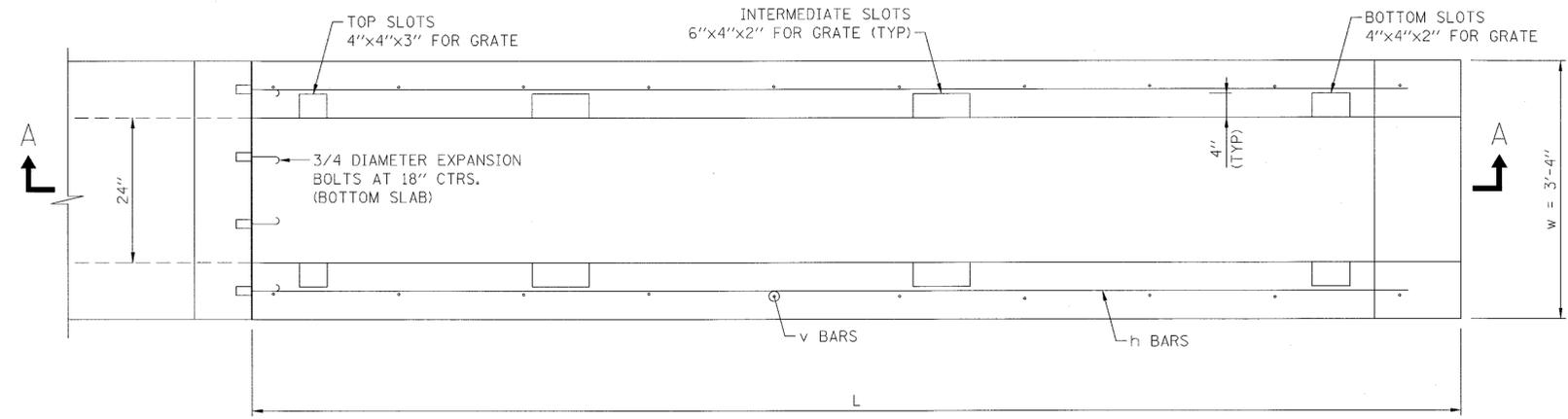

TYPICAL GRATE (NO SKEW)

GRATE DIMENSIONS AND QUANTITIES IN ONE HEADWALL TYPE IV BASED ON A 1 FOOT WIDTH, 1:3 SLOPE, AND NO SKEW

CULVERT HEIGHT	GRATES		BARS FOR ONE GRATE				HEADWALL GRATES (LBS.) EACH GRATE
	NUMBER REQUIRED	TYPE REQ'D.	BAR NO. 1 BARS REQ'D.	LENGTH	BAR NO. 2 BARS REQ'D.	LENGTH	
24"	1	A	2	2.58	4	2'-4 1/2"	42
	2	B	2			1'-10 1/2"	39

- NOTES:
- v BARS ARE TO BEGIN AT THE CULVERT END OF THE SLOPE HEADWALL
 - 3/4" DIAMETER EXPANSION BOLTS SHALL CONSIST OF SELF DRILLING EXPANSION SHIELDS AND 3/4" DIAMETER HOOKED BOLTS. HOOKED BOLTS SHALL EXTEND A MINIMUM OF 9" INTO NEW CONCRETE WITH ANCHORAGE IN ACCORDANCE WITH THE STANDARD SPECIFICATIONS. MINIMUM CERTIFIED PROOF LOAD= 4,080 LBS.

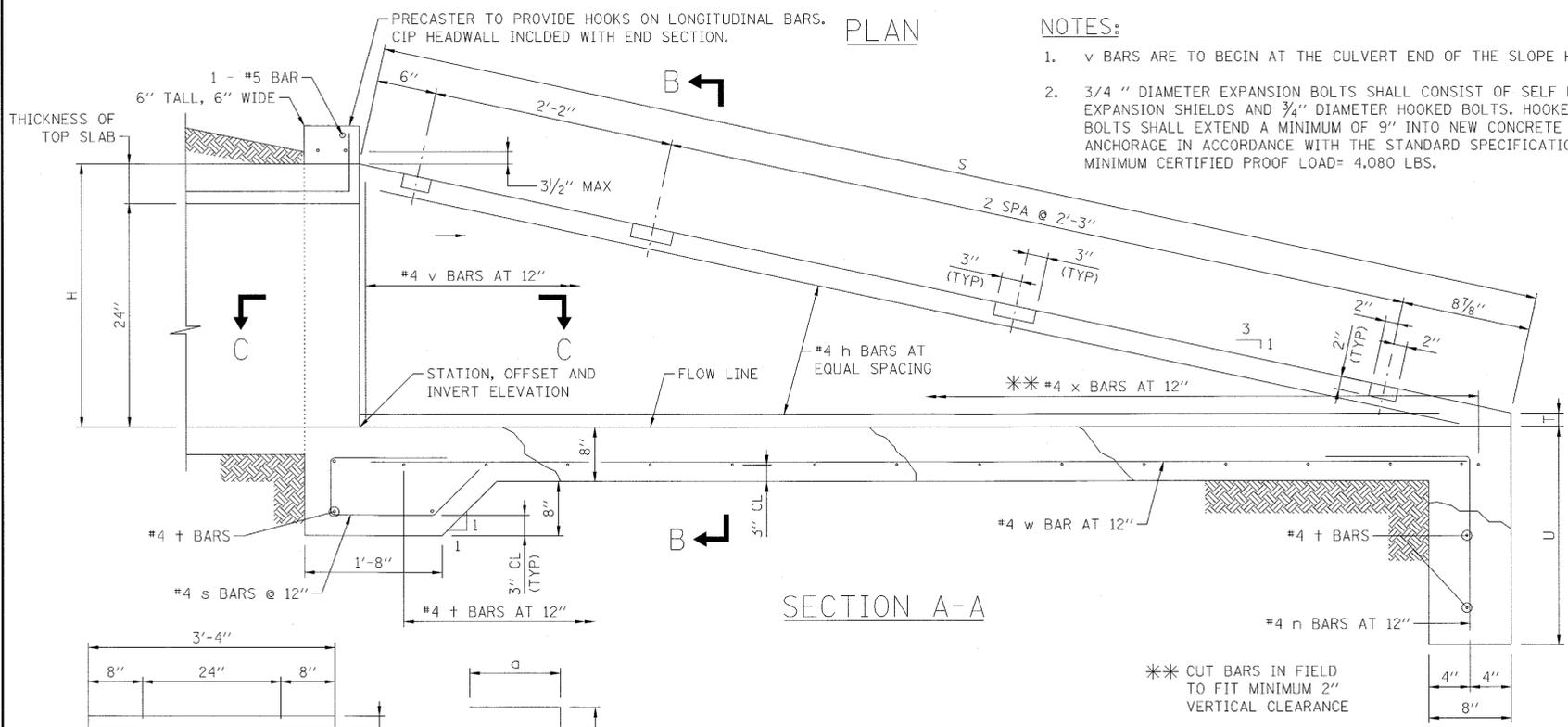

SECTION A-A

TABLE OF BARS IN ONE END SECTION 1:3 SLOPE

NO. 4 REINFORCING BARS						
CULVERT HEIGHT	MARK	TYPE	NO. REQ'D	LENGTH	a	b
24"	h	STR.	4	7'-2"		
	3/4" EXP BLT	---	4	---		
	v 24	2	6	2'-10"	0'-7"	2'-3"
	x 24	1	8	2'-0"	1'-0"	1'-0"

TABLE OF BARS IN SLAB

NO. 4 REINFORCING BARS						
CULVERT HEIGHT	MARK	TYPE	NO. REQ'D	LENGTH	a	b
24"	n 24	1	4	4'-7"	2'-7"	2'-0"
	w 24	STR.	4	7'-2"		
	t 24	STR	8	3'-0"		
	s 24	3	4	3'-7"		

DIMENSIONS FOR TWO END SECTIONS 1:3 SLOPE

CULVERT HEIGHT	DIMENSIONS					
	H	L	S	T	U	A
24"	2'-8"	7'-6"	7'-10 1/8"	2"	3'-2"	2'-2"

GENERAL NOTES:

- ALL EXPOSED CONCRETE EDGES SHALL HAVE A 3/4" X 45° CHAMFER. CHAMFER ON VERTICAL EDGES SHALL BE CONTINUED A MINIMUM OF ONE FOOT BELOW FINISHED GROUND LEVEL.
- COVER FROM THE FACE OF CONCRETE TO FACE OF REINFORCEMENT BARS SHALL BE 2" UNLESS OTHERWISE SHOWN.
- ALL SLOPES ARE EXPRESSED AS UNITS OF VERTICAL DISPLACEMENT TO UNITS OF HORIZONTAL DISPLACEMENT (V:H).

NOTES:

- TYPE 2 "v" BARS SHALL BE ORDERED FULL LENGTH AND CUT IN THE FIELD. THE REMAINING PORTION OF THE "v" BARS SHALL BE USED IN THE OTHER WALL.
- THE LONG LEG OF THE "n" BAR SHALL BE VERTICAL.
- HEADWALL AND GRATE ARE INCLUDED IN THE COST OF BOX CULVERT END SECTIONS, CULVERT NO. 1.
- FOR INFORMATION ONLY: MATERIALS REQUIRED PER END SECTION: CONCRETE 1.5 CY, REINFORCING BARS 190 LBS.

FILE NAME = 74754-shb-drain-06102.dgn

	USER NAME = rjiang	DESIGNED = JAR	REVISED =	STATE OF ILLINOIS DEPARTMENT OF TRANSPORTATION	DRAINAGE DETAILS BOX CULVERT END SECTION DETAILS			F.A.U. RTE. 2298	SECTION 13-00215-30-PV	COUNTY KANE	TOTAL SHEETS 177	SHEET NO. 69
	PLOT SCALE = 40,0000' / in.	CHECKED = RMG	REVISED =		SCALE:	SHEET	OF	SHEETS	STA.	TO STA.	CONTRACT NO. 61D16	
	PLOT DATE = 9/1/2017	DATE = 9/5/2017	REVISED =					ILLINOIS FED. AID PROJECT				

POINT	STATION	O/S (LT)
A	2280+22.11	299.48
B	2280+08.93	276.72
C	2279+88.57	212.26
D	2279+86.20	192.36
E	2279+89.40	169.88
F	2279+96.15	163.44
G	2280+88.66	159.97
H	2281+43.88	141.16
I	2281+64.07	126.8
J	2281+77.72	126.87
K	2282+09.76	141.04
L	2282+28.30	138.15
M	2282+30.80	143.31
N	2282+16.10	160.08
O	2282+11.91	166.27
P	2282+01.86	177.69
Q	2281+62.73	202.29
R	2281+49.29	206.53
S	2281+26.71	221.96
T	2281+03.69	232.47
U	2280+78.57	237.06
V	2280+42.33	287.26
W	2282+31.36	123.71
X	2282+46.89	118.48
Y	2282+53.62	119.9
Z	2282+68.42	122.28
AA	2282+79.68	120.38
AB	2282+83.91	122.92
AC	2282+83.62	127.4
AD	2282+70.29	140.23
AE	2282+50.13	148.49
AF	2282+26.42	164.64

MH A-61, TY A, 5' DIA TYIF CL
 STA 2281+00.00, 43.57 LT
 RIM 896.00
 IE 889.97

MH A-62, TY A, 5' DIA TYIF CL
 STA 2279+00.24, 67.69 LT
 RIM 900.50
 IE 879.00

FES A-63
 STA 2279+72.43, 144.29 LT
 IE 878.44

NOTES:
 1. IF SLOUGHING OF SOIL OCCURS DURING CONSTRUCTION, THE ENGINEER SHALL DETERMINE IF RIP RAP AND FILTER FABRIC SHOULD BE USED TO STABILIZE THE SLOPES.

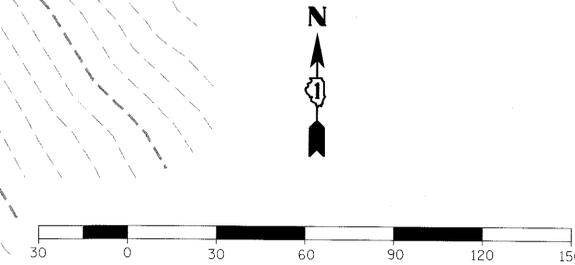
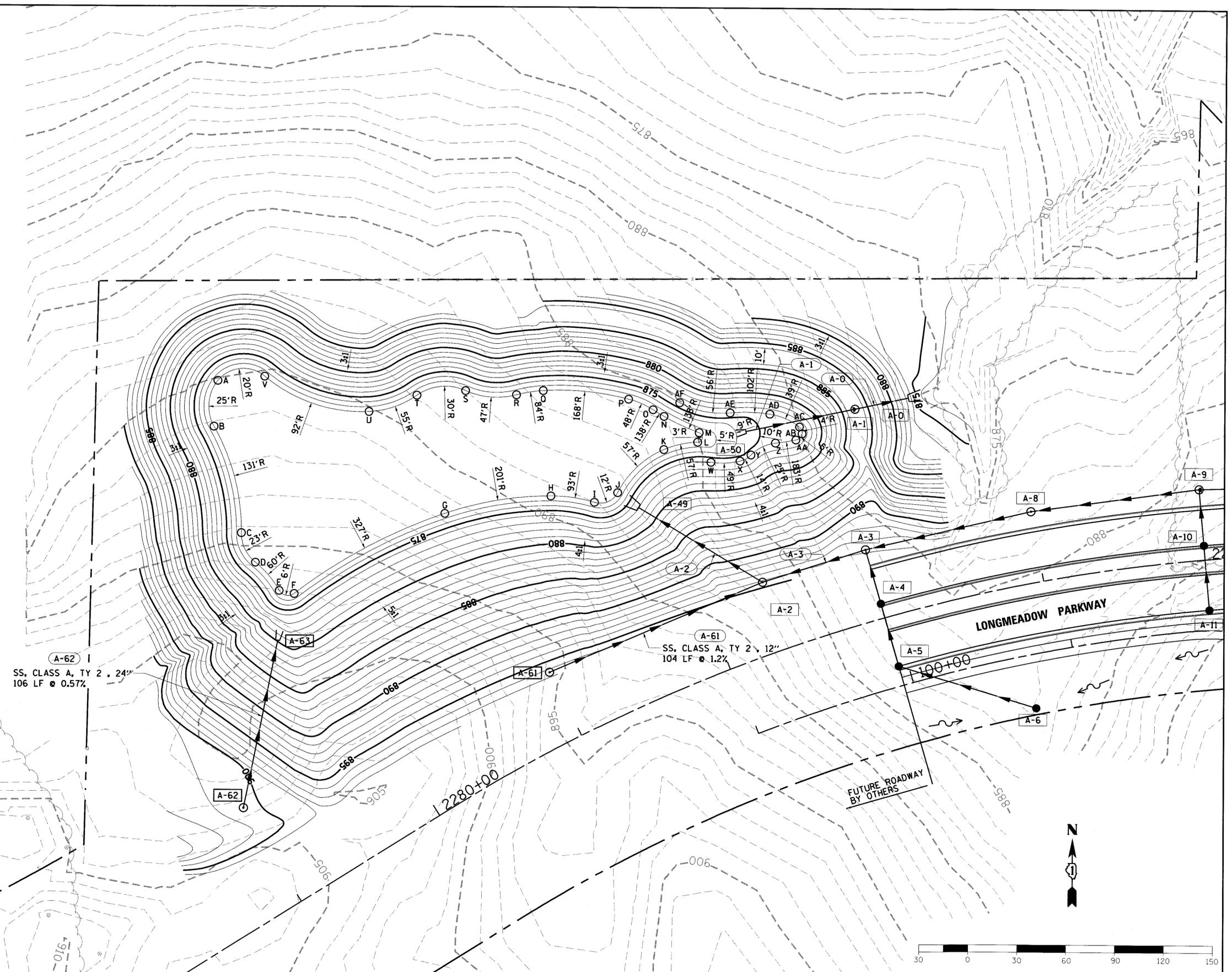

FILE NAME = 72754-sh-basindgn

	USER NAME = r.jiang	DESIGNED - RGJ	REVISED -	STATE OF ILLINOIS DEPARTMENT OF TRANSPORTATION	DETENTION BASIN GRADING PLAN		F.A.U. RTE. 2298	SECTION 13-00215-30-PV	COUNTY KANE	TOTAL SHEETS 177	SHEET NO. 70
	PLOT SCALE = 60,0000' / in.	CHECKED - CFZ	REVISED -				SCALE: 1" = 30' SHEET 1 OF 1 SHEETS STA. TO STA.		CONTRACT NO. 61D16		
	PLOT DATE = 9/1/2017	DATE - 9/5/2017	REVISED -				ILLINOIS FED. AID PROJECT				

STATE OF ILLINOIS
DEPARTMENT OF TRANSPORTATION
DIVISION OF HIGHWAYS
PLAT OF HIGHWAYS

**LONGMEADOW PARKWAY
SECTION NO. 94-00215-01-ES
COUNTY: KANE COUNTY, IL
LIMITS: (INTERSECTION AT IL RTE 62)
JOB NO. R-91-020-02**

PARCEL NUMBER	OWNER	SHEET NUMBER	PROPERTY ACQUIRED BY
1LN0001	NICK NERO AND ROSEMARY NERO	2, 3	
1LN0002 1LN0002TE	ROBERT A. BRANDT AND MARY E. BRANDT HUSBAND AND WIFE IN JOINT TENANCY	2, 3, 4	
1LN0003 1LN0003TE	IAN S. MACDONALD AND STACY M. MACDONALD, HUSBAND AND WIFE, AS TENANTS BY THE ENTIRETY	2, 3	
1LN0004	GEOEGE S. TOMARAS	2, 3	
1LN0005 1LN0005TE-A 1LN0005TE-B	KEVIN BARNES AND GAYLE BARNES, HIS WIFE, AS TENANTS BY THE ENTIRETY	2, 4, 5	
1LN0006	DONALD G. HEIN AND THERESA A. HEIN AS TRUSTEES UNDER TRUST AGREEMENT DATED JUNE 11, 1992	2, 4	
1LN0007 1LN0007TE	CHESTNUT TRAILS, L.L.C.	2, 5	
1LN0008	MARIUSZ BIALAS AND RENATA HEIBERG, HUSBAND AND WIFE, AS JOINT TENANTS	2, 4, 5	
1LN0104	FRANK TURI	2, 5	

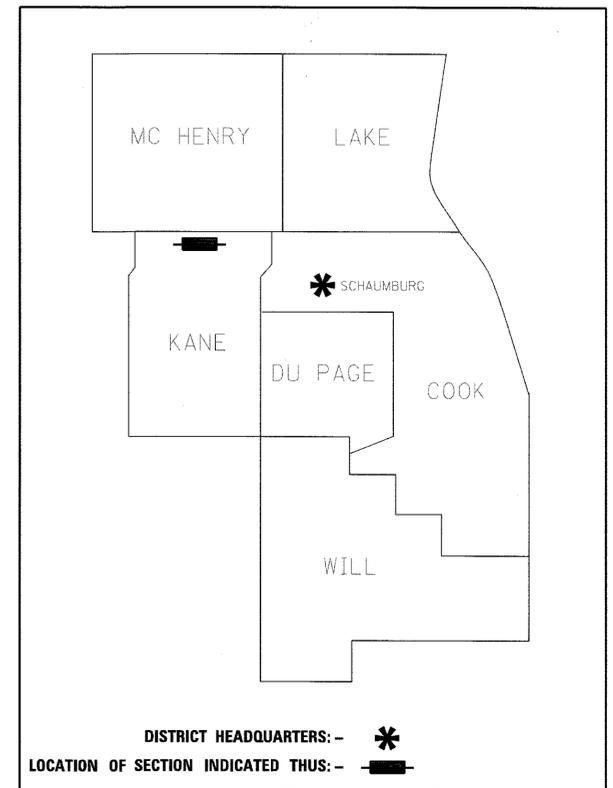

**PRINTED BY THE AUTHORITY
OF THE STATE OF ILLINOIS**

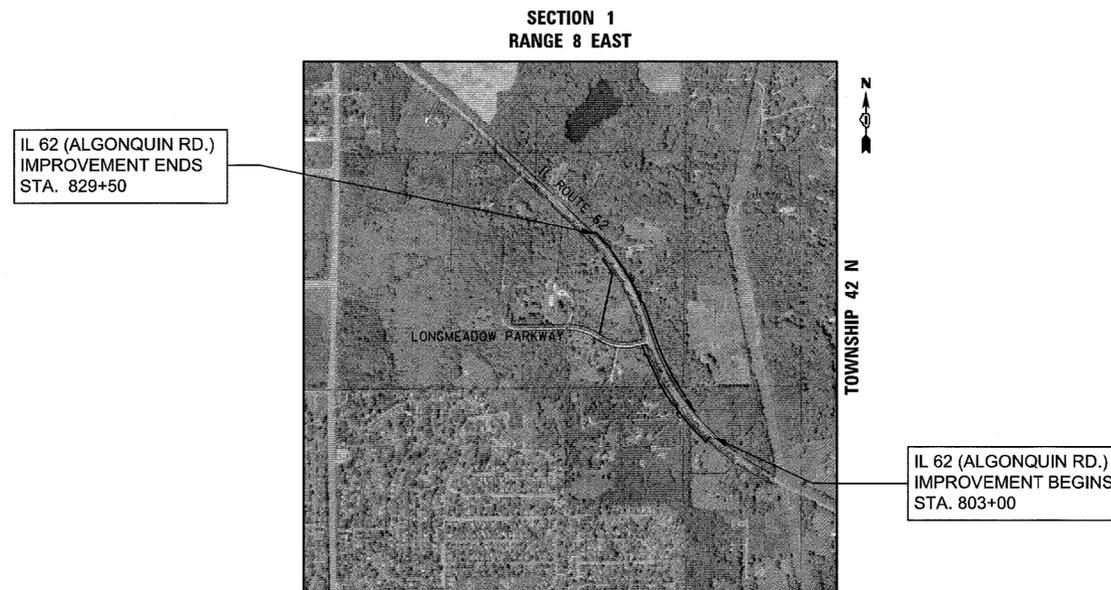

LOCATION MAP
SCALE: 1" = 1000'

LOCATION MAP

NET LENGTH = 2650 FT = 0.502 MILE
GROSS LENGTH = 2650 FT = 0.502 MILE

IDOT USE ONLY

LEGEND



- SECTION / QUARTER SECTION LINE
- PLATTED LOT LINES
- PROPERTY (DEED) LINE
- APPL APPARENT PROPERTY LINE
- EXISTING CENTERLINE
- PROPOSED CENTERLINE
- EXISTING RIGHT OF WAY LINE
- PROPOSED RIGHT OF WAY LINE
- EXISTING EASEMENT
- PROPOSED EASEMENT
- AC EXISTING ACCESS CONTROL LINE
- AC PROPOSED ACCESS CONTROL LINE
- MEASURED DIMENSION
- COMPUTED DIMENSION
- RECORDED DIMENSION
- EXISTING BUILDING



- IRON PIPE OR ROD FOUND
- ⊕ 'MAG' NAIL SET
- + CUT CROSS FOUND OR SET
- ⊙ 5 / 8" REBAR SET
- STAKING OF PROPOSED RIGHT OF WAY. SET DIVISION OF HIGHWAYS SURVEY MARKER TO MONUMENT THE POSITION SHOWN, IDENTIFIED BY INSCRIPTION DATA AND SURVEYORS REGISTRATION NUMBER.
- M STAKING OF PROPOSED RIGHT OF WAY IN CULTIVATED AREAS. BURIED 5/8 INCH METAL ROD 20 INCHES BELOW GROUND TO MARK FUTURE SURVEY MARKER POSITION IDENTIFIED BY COLORED PLASTIC CAP BEARING SURVEYORS REGISTRATION NUMBER.
- ⊙ PERMANENT SURVEY MARKER, I.D.O.T. STANDARD 2135 (TO BE SET BY OTHERS)
- RIGHT OF WAY STAKING PROPOSED TO BE SET

STATE OF ILLINOIS)
 COUNTY OF KANE)

THIS IS TO CERTIFY THAT I, REJENA LYON, AN ILLINOIS PROFESSIONAL LAND SURVEYOR, HAVE SURVEYED THE PLAT OF HIGHWAYS SHOWN HEREON IN SECTIONS 1 & 12 TOWNSHIP 42 NORTH, RANGE 8 EAST OF THE THIRD PRINCIPAL MERIDIAN, KANE COUNTY, THAT THE SURVEY IS TRUE AND COMPLETE AS SHOWN TO THE BEST OF MY KNOWLEDGE AND BELIEF, THAT THE PLAT CORRECTLY REPRESENTS SAID SURVEY, THAT ALL MONUMENTS FOUND AND ESTABLISHED ARE OF PERMANENT QUALITY AND OCCUPY THE POSITIONS SHOWN THEREON AND THAT THE MONUMENTS ARE SUFFICIENT TO ENABLE THE SURVEY TO BE RETRACED, MADE FOR THE DEPARTMENT OF TRANSPORTATION, STATE OF ILLINOIS.

DATED AT _____, ILLINOIS THIS ____ DAY OF _____, 20__ A.D.

ILLINOIS PROFESSIONAL LAND SURVEYOR NO. 3302
 LICENSE EXPIRATION DATE: NOV. 30, 2016

THIS PROFESSIONAL SERVICE CONFORMS TO THE CURRENT ILLINOIS MINIMUM STANDARDS FOR A BOUNDARY SURVEY, FOR THAT PART SHOWN AS PROPOSED RIGHT-OF-WAY.

FIELD WORK COMPLETED 01/08/2015.



HAMPTON, LENZINI AND RENWICK, INC.
 CIVIL ENGINEERS - STRUCTURAL ENGINEERS - LAND SURVEYORS
HLR
 380 SHEPARD DRIVE
 ELGIN, ILLINOIS 60123
 847.697.6700 www.hltrengineering.com

CONTRACT NO. 61D16

PLAT OF HIGHWAYS
 STATE OF ILLINOIS
 DEPARTMENT OF TRANSPORTATION
 LONGMEADOW PARKWAY

LIMITS: @ IL 62 (ALGONQUIN RD.) COUNTY: KANE
 SECTION: 94-00215-01-ES JOB NO.: R-91-020-02
 STA. TO STA.
 SCALE: 1" = 200' SHEET 2 OF 5 SHEETS

BUREAU OF LAND ACQUISITION
 201 WEST CENTER COURT
 SCHAUMBURG, ILLINOIS 60196

IDOT USE ONLY

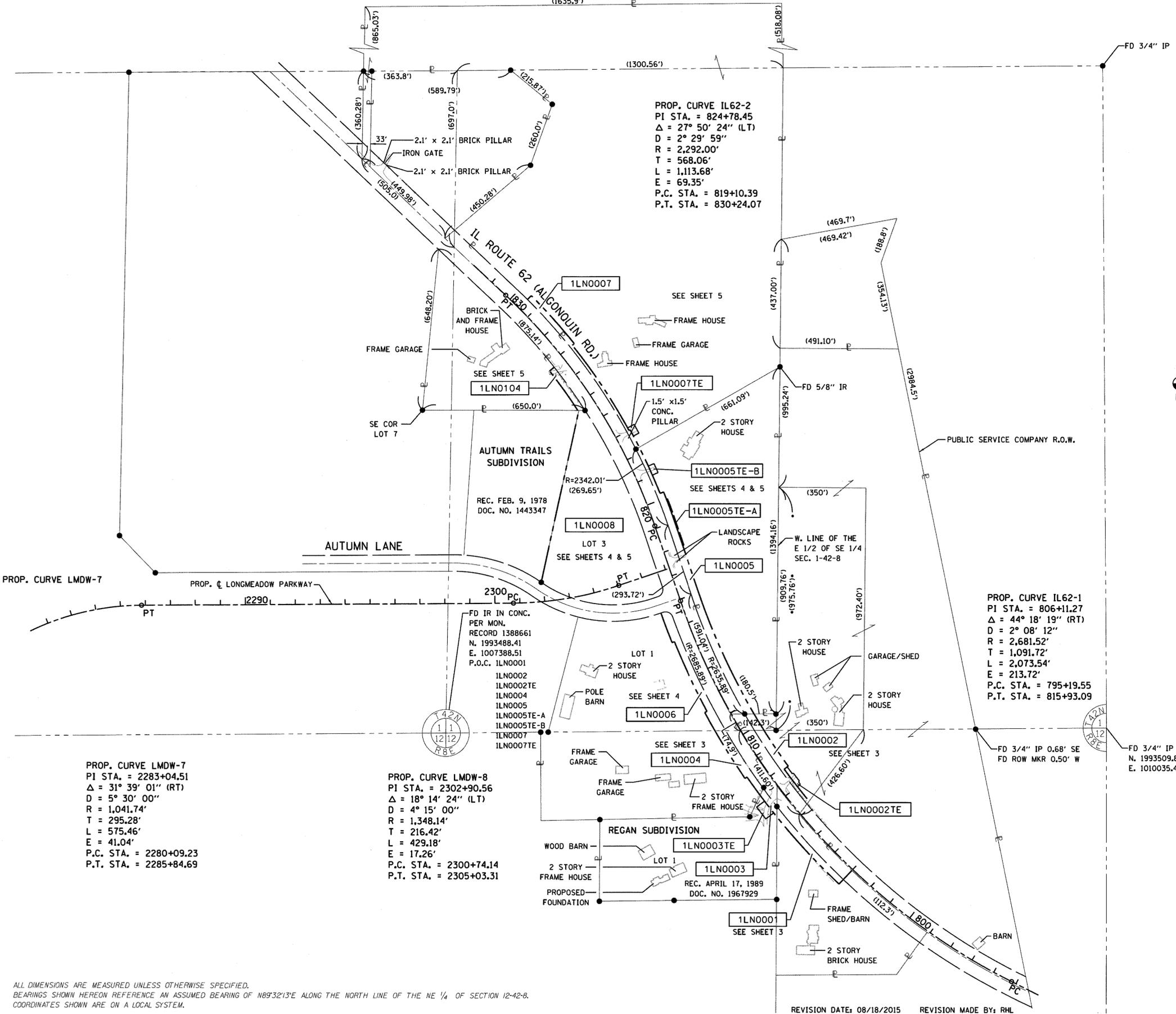

PROP. CURVE IL62-2
 PI STA. = 824+78.45
 $\Delta = 27^\circ 50' 24''$ (LT)
 $D = 2^\circ 29' 59''$
 $R = 2,292.00'$
 $T = 568.06'$
 $L = 1,113.68'$
 $E = 69.35'$
 P.C. STA. = 819+10.39
 P.T. STA. = 830+24.07

PROP. CURVE IL62-1
 PI STA. = 806+11.27
 $\Delta = 44^\circ 18' 19''$ (RT)
 $D = 2^\circ 08' 12''$
 $R = 2,681.52'$
 $T = 1,091.72'$
 $L = 2,073.54'$
 $E = 213.72'$
 P.C. STA. = 795+19.55
 P.T. STA. = 815+93.09

PROP. CURVE LMDW-7
 PI STA. = 2283+04.51
 $\Delta = 31^\circ 39' 01''$ (RT)
 $D = 5^\circ 30' 00''$
 $R = 1,041.74'$
 $T = 295.28'$
 $L = 575.46'$
 $E = 41.04'$
 P.C. STA. = 2280+09.23
 P.T. STA. = 2285+84.69

PROP. CURVE LMDW-8
 PI STA. = 2302+90.56
 $\Delta = 18^\circ 14' 24''$ (LT)
 $D = 4^\circ 15' 00''$
 $R = 1,348.14'$
 $T = 216.42'$
 $L = 429.18'$
 $E = 17.26'$
 P.C. STA. = 2300+74.14
 P.T. STA. = 2305+03.31

ALL DIMENSIONS ARE MEASURED UNLESS OTHERWISE SPECIFIED.
 BEARINGS SHOWN HEREON REFERENCE AN ASSUMED BEARING OF N89°32'13"E ALONG THE NORTH LINE OF THE NE 1/4 OF SECTION 12-42-B.
 COORDINATES SHOWN ARE ON A LOCAL SYSTEM.

REVISION DATE: 08/18/2015 REVISION MADE BY: RHL
 REVISION DATE: 10/25/2016 REVISION MADE BY: RHL

PART OF THE SE 1/4 OF SECTION 1, AND NE 1/4 OF SECTION 12 TWP. 42 N., R. 8 E. OF THE 3RD. P.M., IN KANE COUNTY, ILLINOIS.

LEGEND

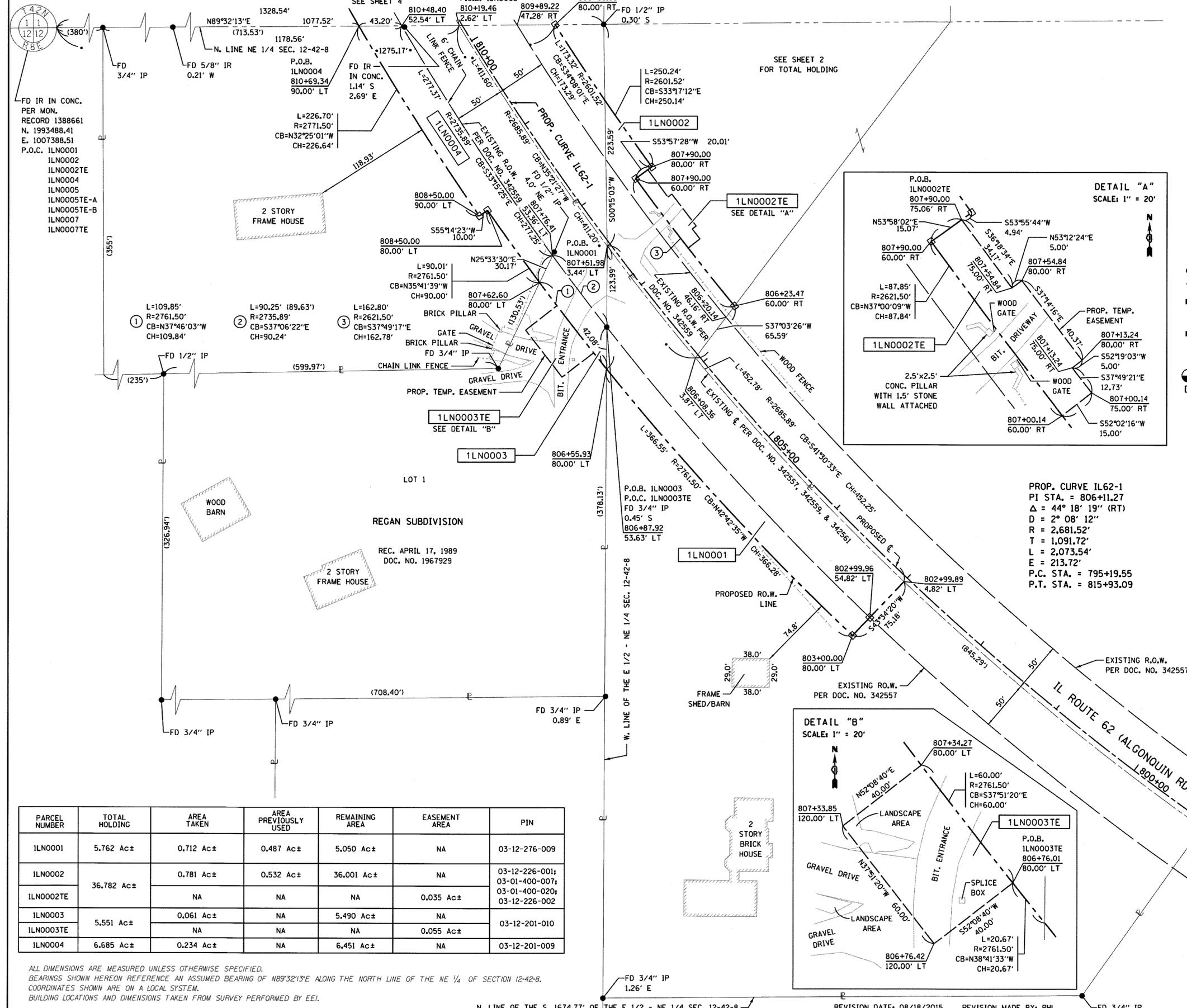
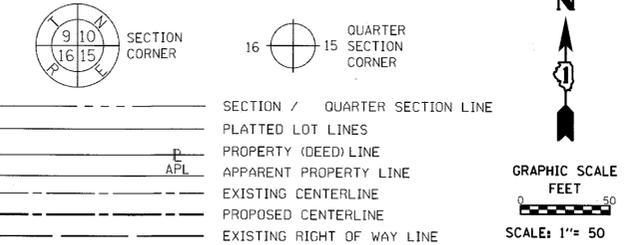

- IRON PIPE OR ROD FOUND
- ⊕ *MAG' NAIL SET
- + CUT CROSS FOUND OR SET
- ⊕ 5 / 8" REBAR SET
- STAKING OF PROPOSED RIGHT OF WAY, SET DIVISION OF HIGHWAYS SURVEY MARKER TO MONUMENT THE POSITION SHOWN, IDENTIFIED BY INSCRIPTION DATA AND SURVEYORS REGISTRATION NUMBER.
- M STAKING OF PROPOSED RIGHT OF WAY IN CULTIVATED AREAS. BURIED 5/8 INCH METAL ROD 20 INCHES BELOW GROUND TO MARK FUTURE SURVEY MARKER POSITION IDENTIFIED BY COLORED PLASTIC CAP BEARING SURVEYORS REGISTRATION NUMBER.
- ⊙ PERMANENT SURVEY MARKER, I.D.O.T. STANDARD 2135 (TO BE SET BY OTHERS)
- RIGHT OF WAY STAKING PROPOSED TO BE SET

STATE OF ILLINOIS)
) JSS
 COUNTY OF KANE)

THIS IS TO CERTIFY THAT I, REJENA LYON, AN ILLINOIS PROFESSIONAL LAND SURVEYOR, HAVE SURVEYED THE PLAT OF HIGHWAYS SHOWN HEREON IN SECTIONS 1 & 12 TOWNSHIP 42 NORTH, RANGE 8 EAST OF THE TRUE PRINCIPAL MERIDIAN, KANE COUNTY, THAT THE SURVEY IS TRUE AND COMPLETE AS SHOWN TO THE BEST OF MY KNOWLEDGE AND BELIEF. THAT THE PLAT CORRECTLY REPRESENTS SAID SURVEY, THAT ALL MONUMENTS FOUND AND ESTABLISHED ARE OF PERMANENT QUALITY AND OCCUPY THE POSITIONS SHOWN THEREON AND THAT THE MONUMENTS ARE SUFFICIENT TO ENABLE THE SURVEY TO BE RETRACED, MADE FOR THE DEPARTMENT OF TRANSPORTATION, STATE OF ILLINOIS.

DATED AT _____, ILLINOIS THIS ____ DAY OF _____ 20__ A.D.

ILLINOIS PROFESSIONAL LAND SURVEYOR NO. 3302
 LICENSE EXPIRATION DATE: NOV. 30, 2016

THIS PROFESSIONAL SERVICE CONFORMS TO THE CURRENT ILLINOIS MINIMUM STANDARDS FOR A BOUNDARY SURVEY, FOR THAT PART SHOWN AS PROPOSED RIGHT-OF-WAY.
 FIELD WORK COMPLETED 01/08/2015.



HAMPTON, LENZINI AND RENWICK, INC.
 CIVIL ENGINEERS - STRUCTURAL ENGINEERS - LAND SURVEYORS
HLR
 380 SHEPARD DRIVE
 ELGIN, ILLINOIS 60123
 847.697.6700 www.hlrengineering.com

CONTRACT NO. 61D16

PLAT OF HIGHWAYS
 STATE OF ILLINOIS
 DEPARTMENT OF TRANSPORTATION
 LONGMEADOW PARKWAY

LIMITS: @ IL 62 (ALGONQUIN RD.) COUNTY: KANE
 SECTION: 94-00215-01-ES JOB NO.: R-91-020-02
 STA. 799+00 TO STA. 810+00
 SCALE: 1" = 50' SHEET 3 OF 5 SHEETS

BUREAU OF LAND ACQUISITION
 201 WEST CENTER COURT
 SCHAMBURG, ILLINOIS 60196

PARCEL NUMBER	TOTAL HOLDING	AREA TAKEN	AREA PREVIOUSLY USED	REMAINING AREA	EASEMENT AREA	PIN
1LN0001	5.762 Ac±	0.712 Ac±	0.487 Ac±	5.050 Ac±	NA	03-12-276-009
1LN0002	36.782 Ac±	0.781 Ac±	0.532 Ac±	36.001 Ac±	NA	03-12-226-001; 03-01-400-007; 03-01-400-020; 03-12-226-002
1LN0002TE		NA	NA	NA	0.035 Ac±	
1LN0003	5.551 Ac±	0.061 Ac±	NA	5.490 Ac±	NA	03-12-201-010
1LN0003TE	6.685 Ac±	NA	NA	NA	0.055 Ac±	
1LN0004		0.234 Ac±	NA	6.451 Ac±	NA	03-12-201-009

ALL DIMENSIONS ARE MEASURED UNLESS OTHERWISE SPECIFIED.
 BEARINGS SHOWN HEREON REFERENCE AN ASSUMED BEARING OF N89°32'13"E ALONG THE NORTH LINE OF THE NE 1/4 OF SECTION 12-42-8.
 COORDINATES SHOWN ARE ON A LOCAL SYSTEM.
 BUILDING LOCATIONS AND DIMENSIONS TAKEN FROM SURVEY PERFORMED BY EEI.

PART OF THE SE 1/4 OF SECTION 1, AND NE 1/4 OF SECTION 12 TWP. 42 N., R. 8 E. OF THE 3RD. P.M., IN KANE COUNTY, ILLINOIS.

LEGEND

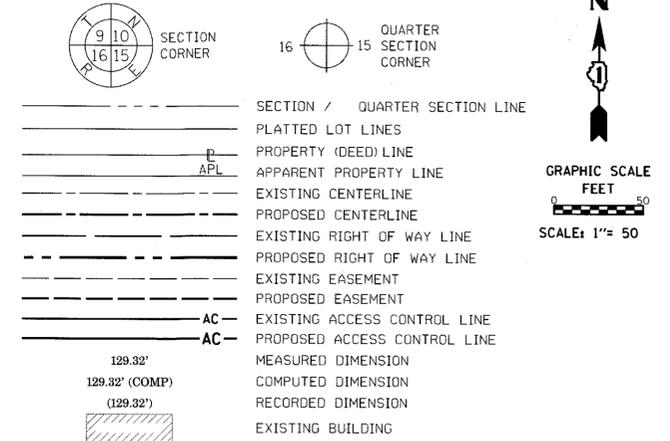

- IRON PIPE OR ROD FOUND
- ⊕ *MAG' NAIL SET
- + CUT CROSS FOUND OR SET
- ⊙ 5 / 8" REBAR SET
- STAKING OF PROPOSED RIGHT OF WAY. SET DIVISION OF HIGHWAYS SURVEY MARKER TO MONUMENT THE POSITION SHOWN, IDENTIFIED BY INSCRIPTION DATA AND SURVEYORS REGISTRATION NUMBER.
- M STAKING OF PROPOSED RIGHT OF WAY IN CULTIVATED AREAS. BURIED 5/8 INCH METAL ROD 20 INCHES BELOW GROUND TO MARK FUTURE SURVEY MARKER POSITION IDENTIFIED BY COLORED PLASTIC CAP BEARING SURVEYORS REGISTRATION NUMBER.
- ⊙ PERMANENT SURVEY MARKER, I.D.O.T. STANDARD 2135 (TO BE SET BY OTHERS)
- RIGHT OF WAY STAKING PROPOSED TO BE SET

STATE OF ILLINOIS)
) JSS
 COUNTY OF KANE)

THIS IS TO CERTIFY THAT I, REJENA LYON, AN ILLINOIS PROFESSIONAL LAND SURVEYOR, HAVE SURVEYED THE PLAT OF HIGHWAYS SHOWN HEREON IN SECTIONS 1 & 12 TOWNSHIP 42 NORTH, RANGE 8 EAST OF THE THIRD PRINCIPAL MERIDIAN, KANE COUNTY, THAT THE SURVEY IS TRUE AND COMPLETE AS SHOWN TO THE BEST OF MY KNOWLEDGE AND BELIEF. THAT THE PLAT CORRECTLY REPRESENTS SAID SURVEY, THAT ALL MONUMENTS FOUND AND ESTABLISHED ARE OF PERMANENT QUALITY AND OCCUPY THE POSITIONS SHOWN THEREON AND THAT THE MONUMENTS ARE SUFFICIENT TO ENABLE THE SURVEY TO BE RETRACED, MADE FOR THE DEPARTMENT OF TRANSPORTATION, STATE OF ILLINOIS.

DATED AT _____, ILLINOIS THIS ____ DAY OF _____, 20__ A.D.

ILLINOIS PROFESSIONAL LAND SURVEYOR NO. _____ 3302
 LICENSE EXPIRATION DATE: NOV. 30, 2016

THIS PROFESSIONAL SERVICE CONFORMS TO THE CURRENT ILLINOIS MINIMUM STANDARDS FOR A BOUNDARY SURVEY, FOR THAT PART SHOWN AS PROPOSED RIGHT-OF-WAY.

FIELD WORK COMPLETED 01/08/2015.



HAMPTON, LENZINI AND RENWICK, INC.
 CIVIL ENGINEERS • STRUCTURAL ENGINEERS • LAND SURVEYORS
 380 SHEPARD DRIVE
 ELGIN, ILLINOIS 60123
 847.697.6700 www.hlrengineering.com

184.000959
 ILLINOIS PROFESSIONAL DESIGN FIRM LS / PE / SE CORPORATION
 JOB: 13.0059.330

CONTRACT NO. 61D16

PLAT OF HIGHWAYS
 STATE OF ILLINOIS
 DEPARTMENT OF TRANSPORTATION
 LONGMEADOW PARKWAY

LIMITS: @ IL 62 (ALGONQUIN RD.) COUNTY: KANE
 SECTION: 94-00215-01-ES JOB NO.: R-91-020-02
 STA. 810+00 TO STA. 821+00
 SCALE: 1" = 50' SHEET 4 OF 5 SHEETS

BUREAU OF LAND ACQUISITION
 201 WEST CENTER COURT
 SCHAUMBURG, ILLINOIS 60196

IDOT USE ONLY

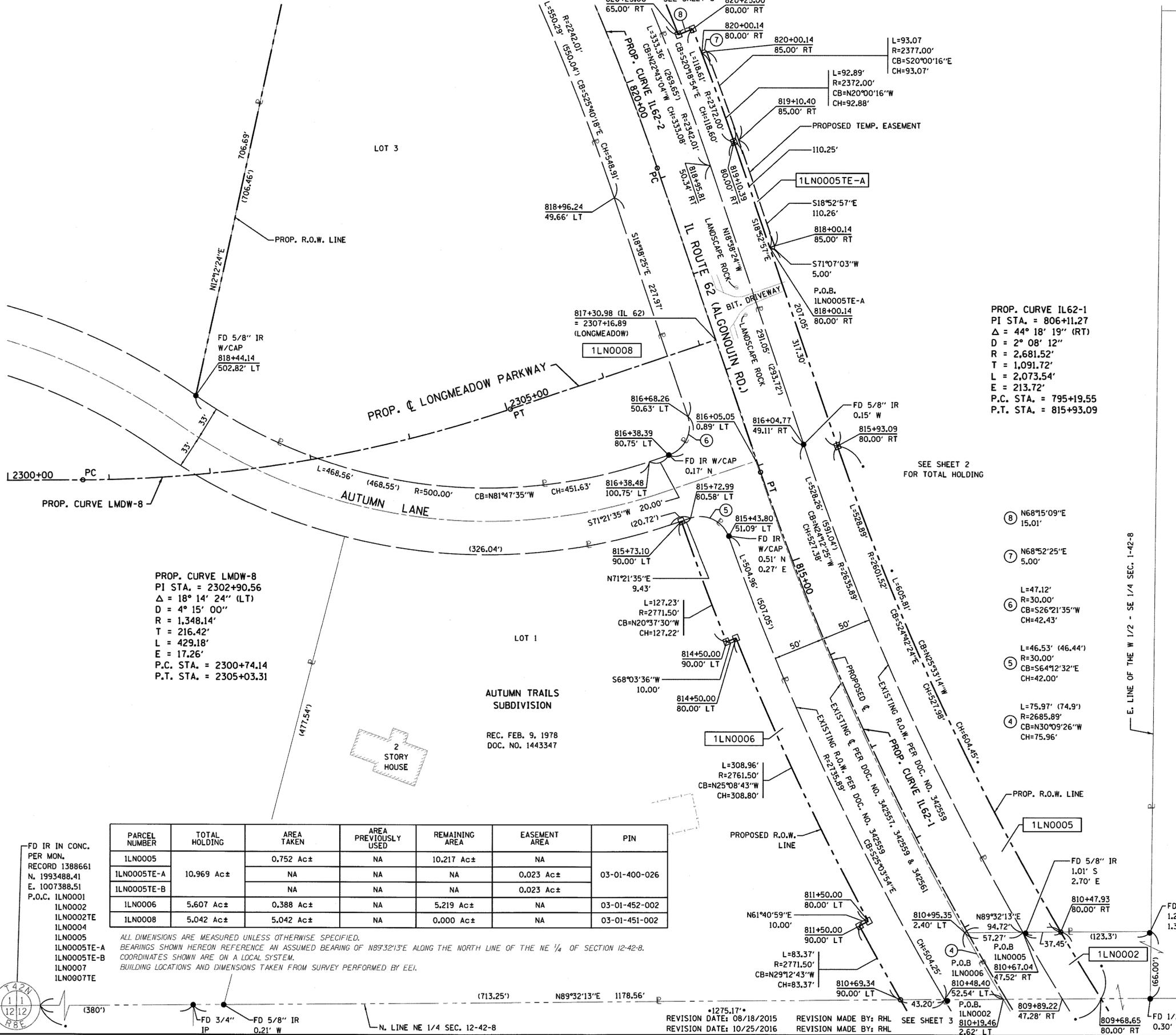

PARCEL NUMBER	TOTAL HOLDING	AREA TAKEN	AREA PREVIOUSLY USED	REMAINING AREA	EASEMENT AREA	PIN
1LN0005	10.969 Ac±	0.752 Ac±	NA	10.217 Ac±	NA	03-01-400-026
1LN0005TE-A		NA	NA	NA	0.023 Ac±	
1LN0005TE-B		NA	NA	NA	0.023 Ac±	
1LN0006	5.607 Ac±	0.388 Ac±	NA	5.219 Ac±	NA	03-01-452-002
1LN0008	5.042 Ac±	5.042 Ac±	NA	0.000 Ac±	NA	03-01-451-002

ALL DIMENSIONS ARE MEASURED UNLESS OTHERWISE SPECIFIED.
 BEARINGS SHOWN HEREON REFERENCE AN ASSUMED BEARING OF N89°32'13"E ALONG THE NORTH LINE OF THE NE 1/4 OF SECTION 12-42-B.
 COORDINATES SHOWN ARE ON A LOCAL SYSTEM.
 BUILDING LOCATIONS AND DIMENSIONS TAKEN FROM SURVEY PERFORMED BY EEL.

FD IR IN CONC. PER MON. RECORD 1388661 N. 1993488.41 E. 1007388.51 P.O.C. 1LN0001 1LN0002 1LN0002TE 1LN0004 1LN0005 1LN0005TE-A 1LN0005TE-B 1LN0007 1LN0007TE



REVISION DATE: 08/18/2015
 REVISION DATE: 10/25/2016

REVISION MADE BY: RHL
 REVISION MADE BY: RHL

SEE SHEET 3

PART OF THE SE 1/4 OF SECTION 1, AND NE 1/4 OF SECTION 12 TWP. 42 N., R. 8 E. OF THE 3RD. P.M., IN KANE COUNTY, ILLINOIS.

LEGEND

SECTION / QUARTER SECTION LINE
 PLATTED LOT LINES
 PROPERTY (DEED) LINE
 APPARENT PROPERTY LINE
 EXISTING CENTERLINE
 PROPOSED CENTERLINE
 EXISTING RIGHT OF WAY LINE
 PROPOSED RIGHT OF WAY LINE
 EXISTING EASEMENT
 PROPOSED EASEMENT
 AC EXISTING ACCESS CONTROL LINE
 AC PROPOSED ACCESS CONTROL LINE
 MEASURED DIMENSION
 COMPUTED DIMENSION
 RECORDED DIMENSION
 EXISTING BUILDING

IRON PIPE OR ROD FOUND
 CUT CROSS FOUND OR SET
 STAKING OF PROPOSED RIGHT OF WAY, SET DIVISION OF HIGHWAYS SURVEY MARKER TO MONUMENT THE POSITION SHOWN, IDENTIFIED BY INSCRIPTION DATA AND SURVEYORS REGISTRATION NUMBER.
 STAKING OF PROPOSED RIGHT OF WAY IN CULTIVATED AREAS, BURIED 5/8 INCH METAL ROD 20 INCHES BELOW GROUND TO MARK FUTURE SURVEY MARKER POSITION IDENTIFIED BY COLORED PLASTIC CAP BEARING SURVEYORS REGISTRATION NUMBER.
 PERMANENT SURVEY MARKER, I.D.O.T. STANDARD 2135 (TO BE SET BY OTHERS)
 RIGHT OF WAY STAKING PROPOSED TO BE SET

STATE OF ILLINOIS)
) JSS
 COUNTY OF KANE)

THIS IS TO CERTIFY THAT I, REJENA LYON, AN ILLINOIS PROFESSIONAL LAND SURVEYOR, HAVE SURVEYED THE PLAT OF HIGHWAYS SHOWN HEREON IN SECTIONS 1 & 12 TOWNSHIP 42 NORTH, RANGE 8 EAST OF THE THIRD PRINCIPAL MERIDIAN, KANE COUNTY, THAT THE SURVEY IS TRUE AND COMPLETE AS SHOWN TO THE BEST OF MY KNOWLEDGE AND BELIEF, THAT THE PLAT CORRECTLY REPRESENTS SAID SURVEY, THAT ALL MONUMENTS FOUND AND ESTABLISHED ARE OF PERMANENT QUALITY AND OCCUPY THE POSITIONS SHOWN THEREON AND THAT THE MONUMENTS ARE SUFFICIENT TO ENABLE THE SURVEY TO BE RETRACED, MADE FOR THE DEPARTMENT OF TRANSPORTATION, STATE OF ILLINOIS.

DATED AT _____, ILLINOIS THIS ____ DAY OF _____, 20__ A.D.

ILLINOIS PROFESSIONAL LAND SURVEYOR NO. 3302
 LICENSE EXPIRATION DATE: NOV. 30, 2016

THIS PROFESSIONAL SERVICE CONFORMS TO THE CURRENT ILLINOIS MINIMUM STANDARDS FOR A BOUNDARY SURVEY, FOR THAT PART SHOWN AS PROPOSED RIGHT-OF-WAY.

FIELD WORK COMPLETED 01/08/2015.

HAMPTON, LENZINI AND RENWICK, INC.
 CIVIL ENGINEERS- STRUCTURAL ENGINEERS- LAND SURVEYORS
 380 SHEPARD DRIVE
 ELGIN, ILLINOIS 60123
 847.897.6700 www.hlrengineering.com

164.000959
 ILLINOIS PROFESSIONAL DESIGN FIRM LS / PE / SE CORPORATION
 JOB: 13.0059.330

CONTRACT NO. 61D16

PLAT OF HIGHWAYS
 STATE OF ILLINOIS
 DEPARTMENT OF TRANSPORTATION
 LONGMEADOW PARKWAY

LIMITS: IL 62 (ALGONQUIN RD.) COUNTY: KANE
 SECTION: 94-00215-01-ES JOB NO.: R-91-020-02
 STA. 821+00 TO STA. 830+00
 SCALE: 1" = 50' SHEET 5 OF 5 SHEETS

BUREAU OF LAND ACQUISITION
 201 WEST CENTER COURT
 SCHAMBURG, ILLINOIS 60196

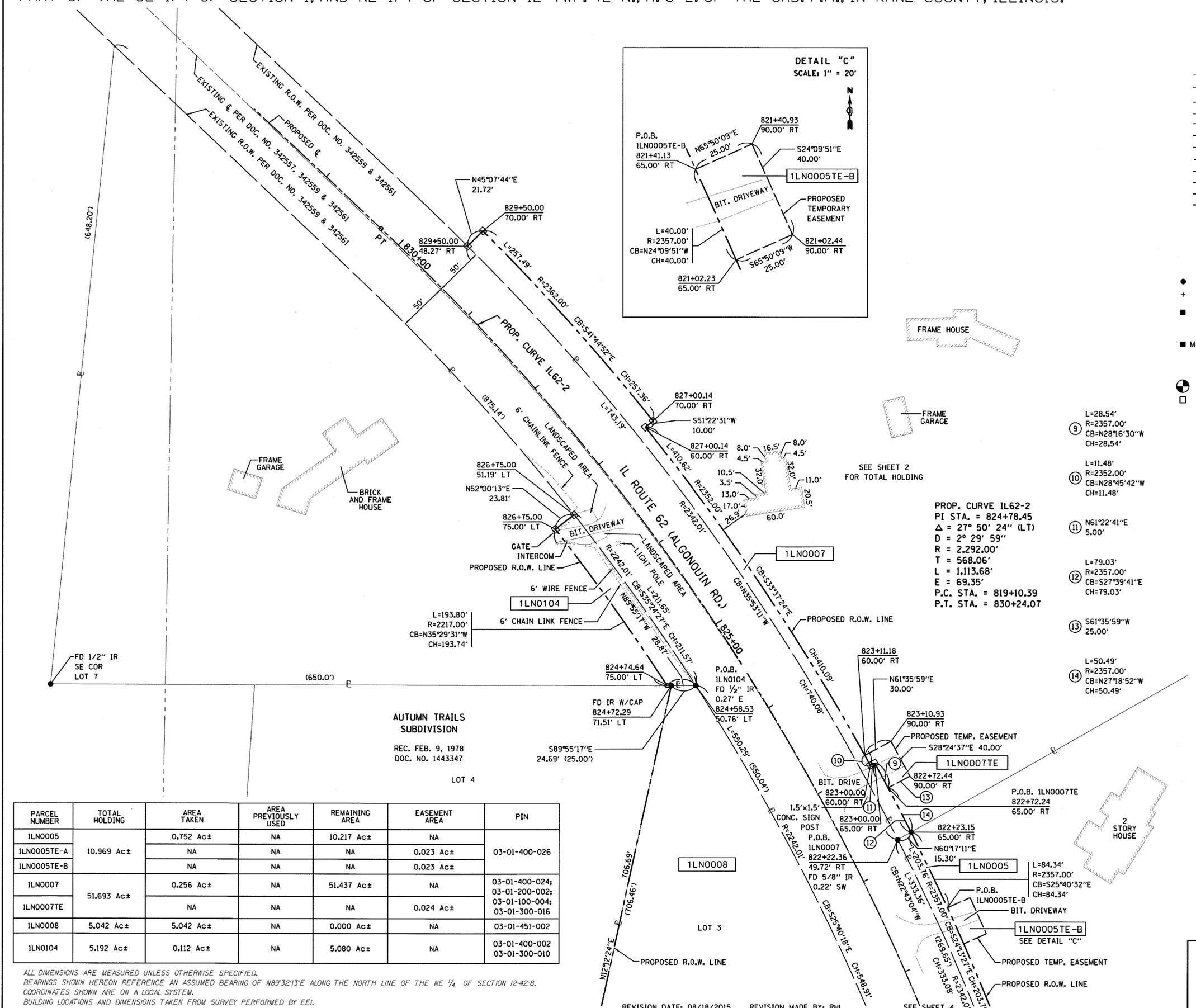

PARCEL NUMBER	TOTAL HOLDING	AREA TAKEN	AREA PREVIOUSLY USED	REMAINING AREA	EASEMENT AREA	PIN
ILN0005	10.969 Ac±	0.752 Ac±	NA	10.217 Ac±	NA	03-01-400-026
ILN0005TE-A		NA	NA	NA	0.023 Ac±	
ILN0005TE-B		NA	NA	NA	0.023 Ac±	
ILN0007	51.693 Ac±	0.256 Ac±	NA	51.437 Ac±	NA	03-01-400-024; 03-01-200-002;
ILN0007TE		NA	NA	NA	0.024 Ac±	03-01-100-004; 03-01-300-016
ILN0008	5.042 Ac±	5.042 Ac±	NA	0.000 Ac±	NA	03-01-451-002
ILN0104	5.192 Ac±	0.112 Ac±	NA	5.080 Ac±	NA	03-01-400-002 03-01-300-010

ALL DIMENSIONS ARE MEASURED UNLESS OTHERWISE SPECIFIED.
 BEARINGS SHOWN HEREON REFERENCE AN ASSUMED BEARING OF N89°32'13"E ALONG THE NORTH LINE OF THE NE 1/4 OF SECTION 12-42-8.
 COORDINATES SHOWN ARE ON A LOCAL SYSTEM.
 BUILDING LOCATIONS AND DIMENSIONS TAKEN FROM SURVEY PERFORMED BY E.E.I.

REVISION DATE: 08/18/2015 REVISION MADE BY: RHL
 REVISION DATE: 10/25/2016 REVISION MADE BY: RHL

LEGEND

(A) LONGITUDINAL CONSTRUCTION JOINT.
DRILL AND GROUT NO. 6 DEFORMED EPOXY TIE BARS
24" LONG AT 24" C-C.
(SHALL BE INCLUDED IN THE COST OF THE APPLICABLE
COMB. CONC. CURB AND GUTTER TYPE)

(B) LONGITUDINAL SAWED JOINT OR CONSTRUCTION JOINT.
FOR LONGITUDINAL SAWED JOINT, POUR IN PLACE
NO. 6 DEFORMED EPOXY TIE BARS 30" LONG AT
30" C-C. FOR LONGITUDINAL CONSTRUCTION JOINT,
DRILL AND GROUT NO. 8 DEFORMED EPOXY TIE BARS
24" LONG AT 24" C-C.
(SHALL BE INCLUDED IN THE COST OF PORTLAND
CEMENT CONCRETE PAVEMENT 10" (JOINTED))

(C) LONGITUDINAL CONSTRUCTION JOINT.
DRILL AND GROUT NO. 8 DEFORMED EPOXY TIE BARS
24" LONG AT 24" C-C.
(SHALL BE INCLUDED IN THE COST OF PORTLAND
CEMENT CONCRETE PAVEMENT 10" (JOINTED))

(D) LONGITUDINAL CONSTRUCTION JOINT.
DRILL AND GROUT NO. 8 DEFORMED EPOXY TIE BARS
30" LONG AT 24" C-C.
(SHALL BE INCLUDED IN THE COST OF THE APPLICABLE
P.C.C. SHOULDERS TYPE)

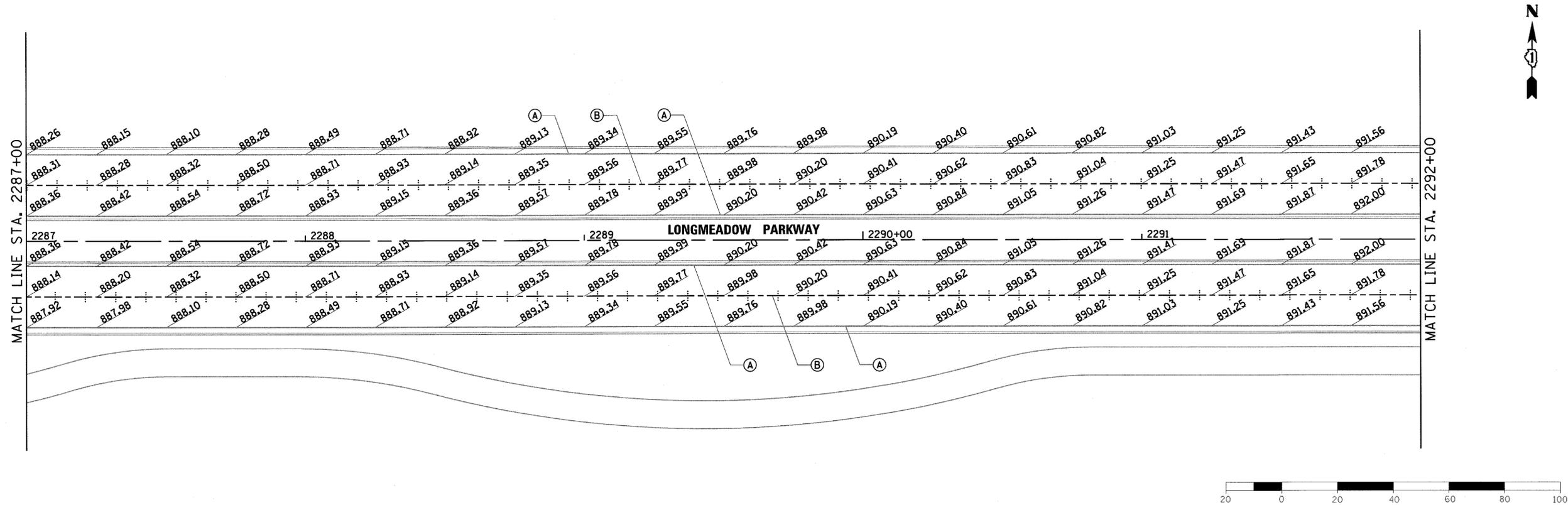
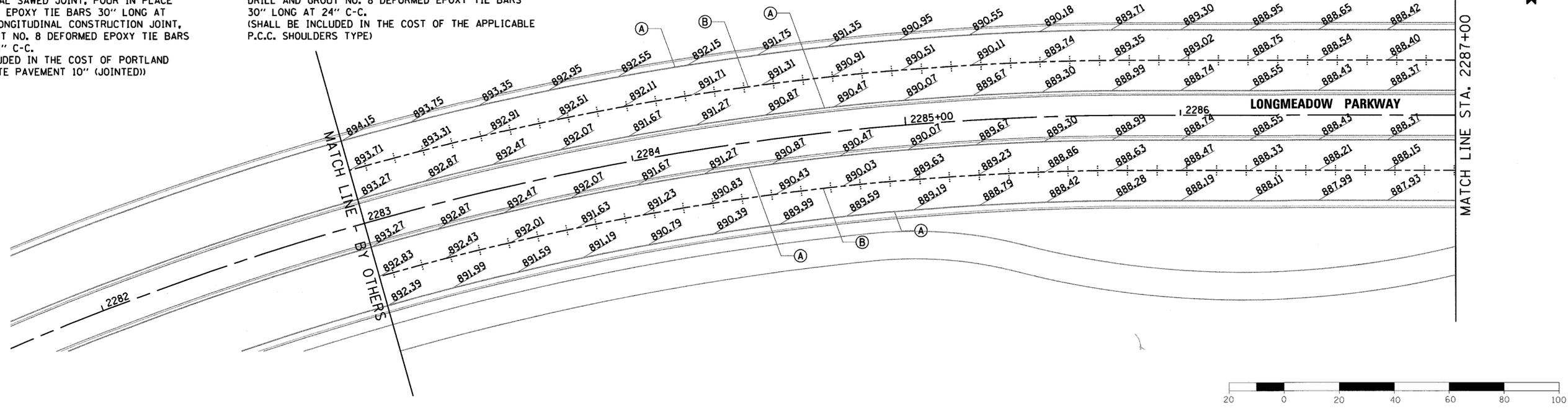

FILE NAME = 74754-ant-pv-jointing.dgn



USER NAME = r.jiang	DESIGNED - RGJ	REVISED -
PLOT SCALE = 48.0000' / in.	DRAWN - RGJ	REVISED -
PLOT DATE = 9/1/2017	CHECKED - RMG	REVISED -
	DATE - 9/5/2017	REVISED -

**STATE OF ILLINOIS
DEPARTMENT OF TRANSPORTATION**

PAVEMENT JOINTING AND ELEVATION PLAN

SCALE: 1" = 20' SHEET 1 OF 6 SHEETS STA. 2283+00.00 TO STA. 2292+00.00

F.A.U. RTE.	SECTION	COUNTY	TOTAL SHEETS	SHEET NO.
2298	13-00215-30-PV	KANE	177	76
CONTRACT NO. 61D16				
ILLINOIS FED. AID PROJECT				

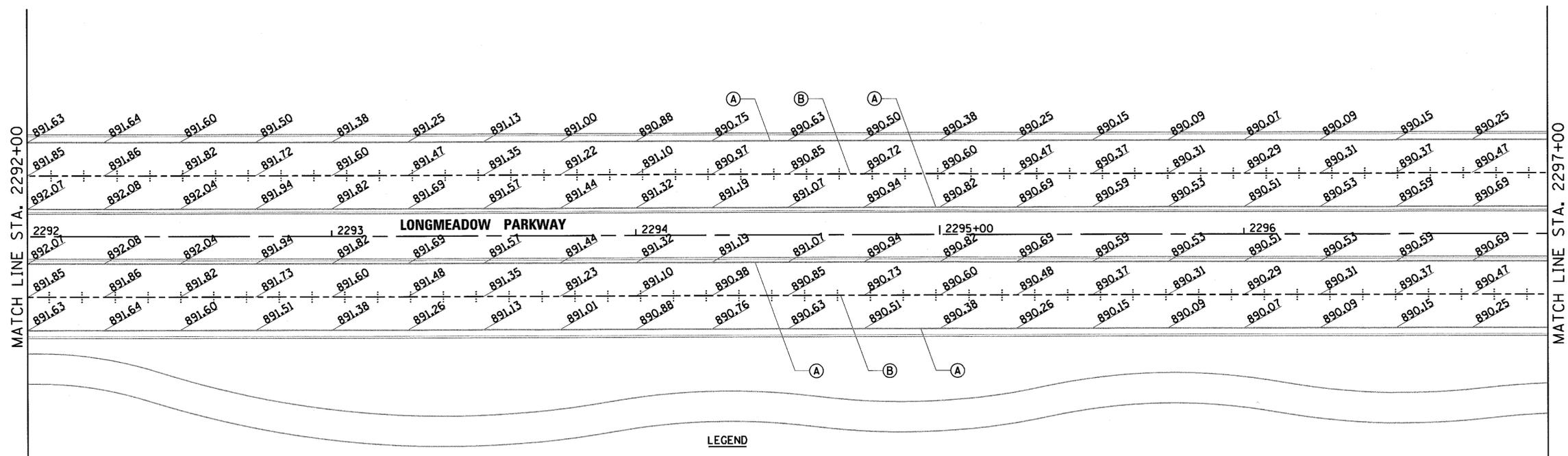

LEGEND

- (A) LONGITUDINAL CONSTRUCTION JOINT. DRILL AND GROUT NO. 6 DEFORMED EPOXY TIE BARS 24" LONG AT 24" C-C. (SHALL BE INCLUDED IN THE COST OF THE APPLICABLE COMB. CONC. CURB AND GUTTER TYPE)
- (B) LONGITUDINAL SAWED JOINT OR CONSTRUCTION JOINT. FOR LONGITUDINAL SAWED JOINT, POUR IN PLACE NO. 6 DEFORMED EPOXY TIE BARS 30" LONG AT 30" C-C. FOR LONGITUDINAL CONSTRUCTION JOINT, DRILL AND GROUT NO. 8 DEFORMED EPOXY TIE BARS 24" LONG AT 24" C-C. (SHALL BE INCLUDED IN THE COST OF PORTLAND CEMENT CONCRETE PAVEMENT 10" (JOINTED))
- (C) LONGITUDINAL CONSTRUCTION JOINT. DRILL AND GROUT NO. 8 DEFORMED EPOXY TIE BARS 24" LONG AT 24" C-C. (SHALL BE INCLUDED IN THE COST OF PORTLAND CEMENT CONCRETE PAVEMENT 10" (JOINTED))
- (D) LONGITUDINAL CONSTRUCTION JOINT. DRILL AND GROUT NO. 8 DEFORMED EPOXY TIE BARS 30" LONG AT 24" C-C. (SHALL BE INCLUDED IN THE COST OF THE APPLICABLE P.C.C. SHOULDERS TYPE)

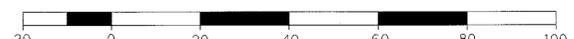
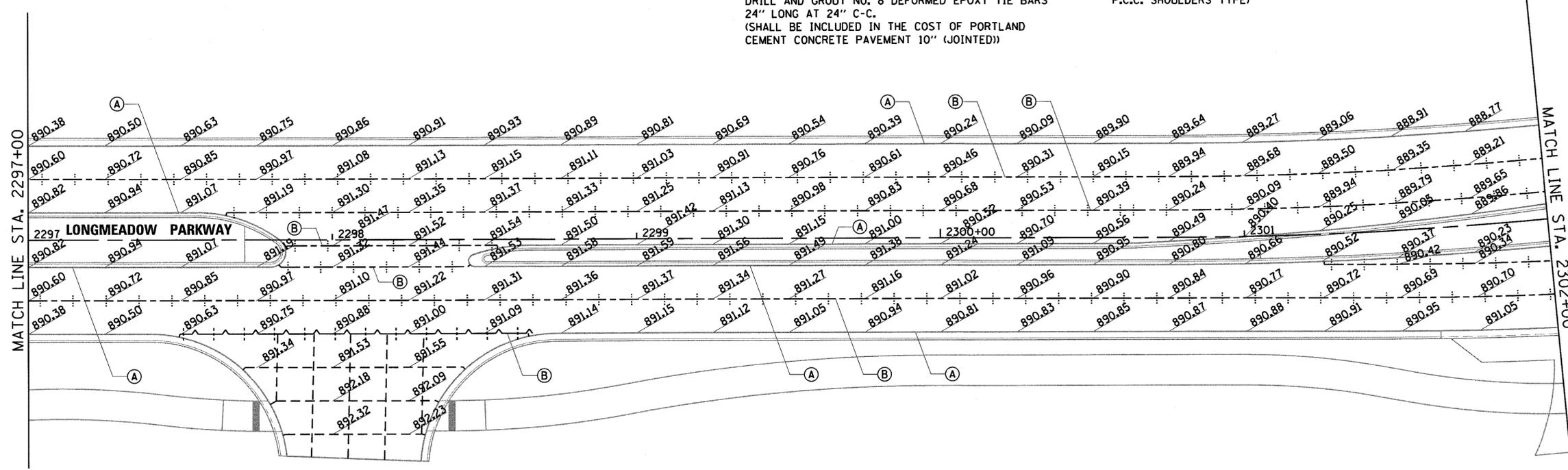

FILE NAME = 74754-rvt-pv-jcm102.dgn



USER NAME = r.jiang	DESIGNED - RGJ	REVISED -
PLOT SCALE = 48.0000' / in.	DRAWN - RGJ	REVISED -
PLOT DATE = 9/1/2017	CHECKED - RMG	REVISED -
	DATE - 9/5/2017	REVISED -

**STATE OF ILLINOIS
DEPARTMENT OF TRANSPORTATION**

PAVEMENT JOINTING AND ELEVATION PLAN

SCALE: 1" = 20' SHEET 2 OF 6 SHEETS STA. 2292+00.00 TO STA. 2302+00.00

F.A.U. RTE.	SECTION	COUNTY	TOTAL SHEETS	SHEET NO.
2298	13-00215-30-PV	KANE	177	77
CONTRACT NO. 61D16				
ILLINOIS FED. AID PROJECT				

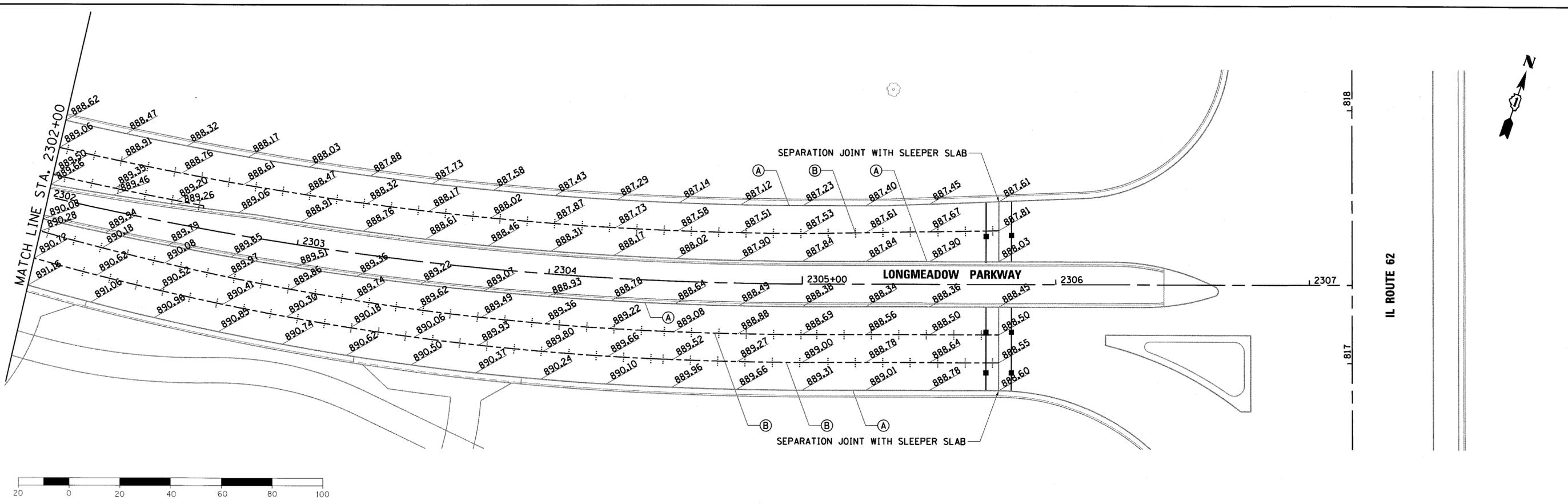

LEGEND

- (A)** LONGITUDINAL CONSTRUCTION JOINT.
 DRILL AND GROUT NO. 6 DEFORMED EPOXY TIE BARS
 24" LONG AT 24" C-C.
 (SHALL BE INCLUDED IN THE COST OF THE APPLICABLE
 COMB. CONC. CURB AND GUTTER TYPE)
- (B)** LONGITUDINAL SAWED JOINT OR CONSTRUCTION JOINT.
 FOR LONGITUDINAL SAWED JOINT, POUR IN PLACE
 NO. 6 DEFORMED EPOXY TIE BARS 30" LONG AT
 30" C-C. FOR LONGITUDINAL CONSTRUCTION JOINT,
 DRILL AND GROUT NO. 8 DEFORMED EPOXY TIE BARS
 24" LONG AT 24" C-C.
 (SHALL BE INCLUDED IN THE COST OF PORTLAND
 CEMENT CONCRETE PAVEMENT 10" (JOINTED))
- (C)** LONGITUDINAL CONSTRUCTION JOINT.
 DRILL AND GROUT NO. 8 DEFORMED EPOXY TIE BARS
 24" LONG AT 24" C-C.
 (SHALL BE INCLUDED IN THE COST OF PORTLAND
 CEMENT CONCRETE PAVEMENT 10" (JOINTED))
- (D)** LONGITUDINAL CONSTRUCTION JOINT.
 DRILL AND GROUT NO. 8 DEFORMED EPOXY TIE BARS
 30" LONG AT 24" C-C.
 (SHALL BE INCLUDED IN THE COST OF THE APPLICABLE
 P.C.C. SHOULDERS TYPE)

FILE NAME = 74754-shr-pvt-joint02.dgn

	USER NAME = r.jiang	DESIGNED - RGJ	REVISED -	STATE OF ILLINOIS DEPARTMENT OF TRANSPORTATION	PAVEMENT JOINTING AND ELEVATION PLAN		F.A.J. RTE. 2298	SECTION 13-00215-30-PV	COUNTY KANE	TOTAL SHEETS 177	SHEET NO. 78	
	PLOT SCALE = 1/8" = 1' / in.	CHECKED - RMG	REVISED -				SCALE: 1" = 20' SHEET 3 OF 6 SHEETS STA. 2302+00.00 TO STA. 2307+16.89		CONTRACT NO. 61D16		ILLINOIS FED. AID PROJECT	
	PLOT DATE = 9/1/2017	DATE - 9/5/2017	REVISED -									

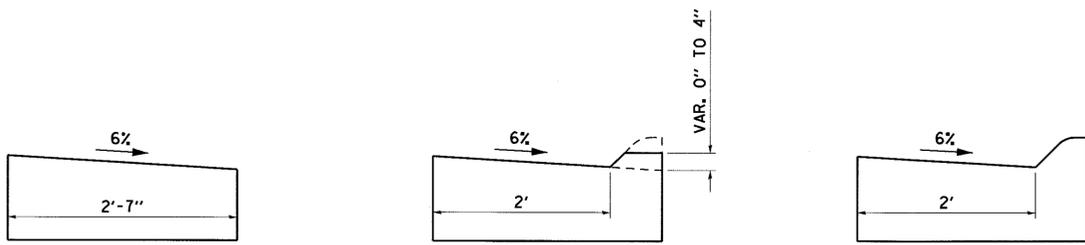
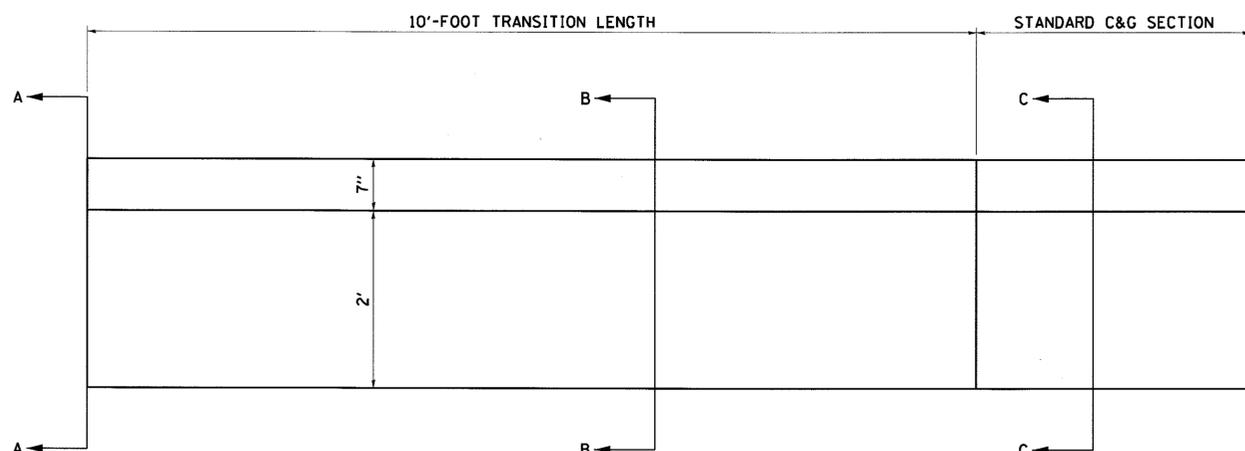

SECTION A-A

SECTION B-B

SECTION C-C

CURB AND GUTTER TRANSITION DETAIL

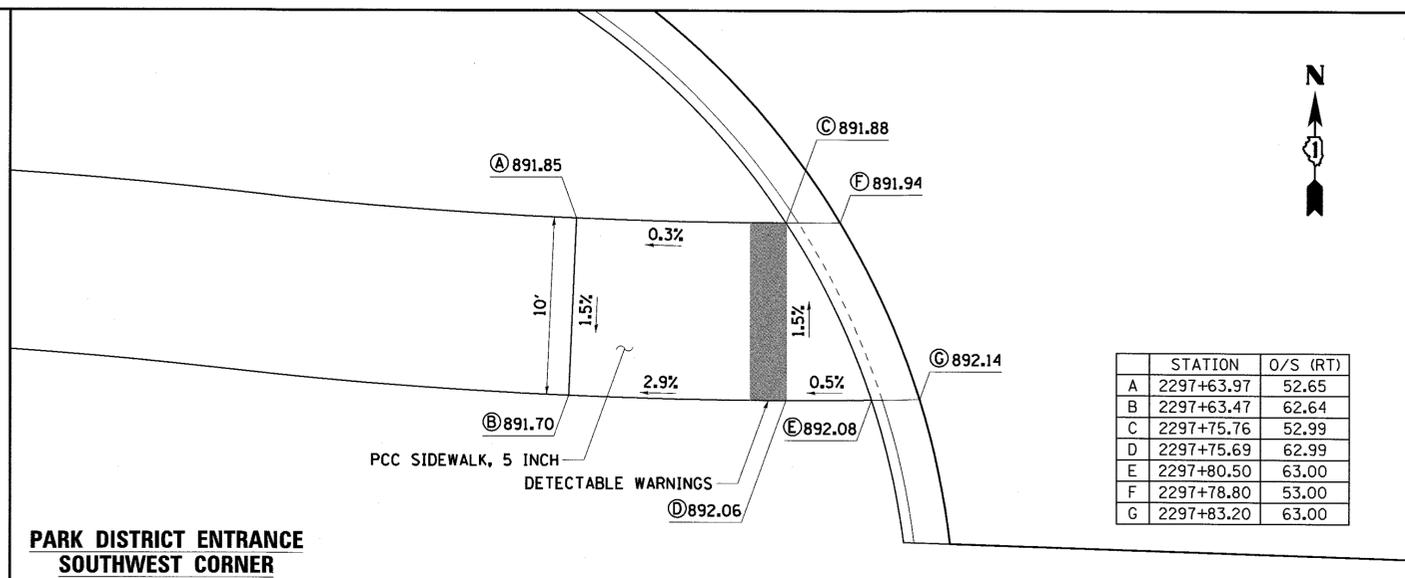

	STATION	O/S (RT)
A	2297+63.97	52.65
B	2297+63.47	62.64
C	2297+75.76	52.99
D	2297+75.69	62.99
E	2297+80.50	63.00
F	2297+78.80	53.00
G	2297+83.20	63.00

PARK DISTRICT ENTRANCE SOUTHWEST CORNER

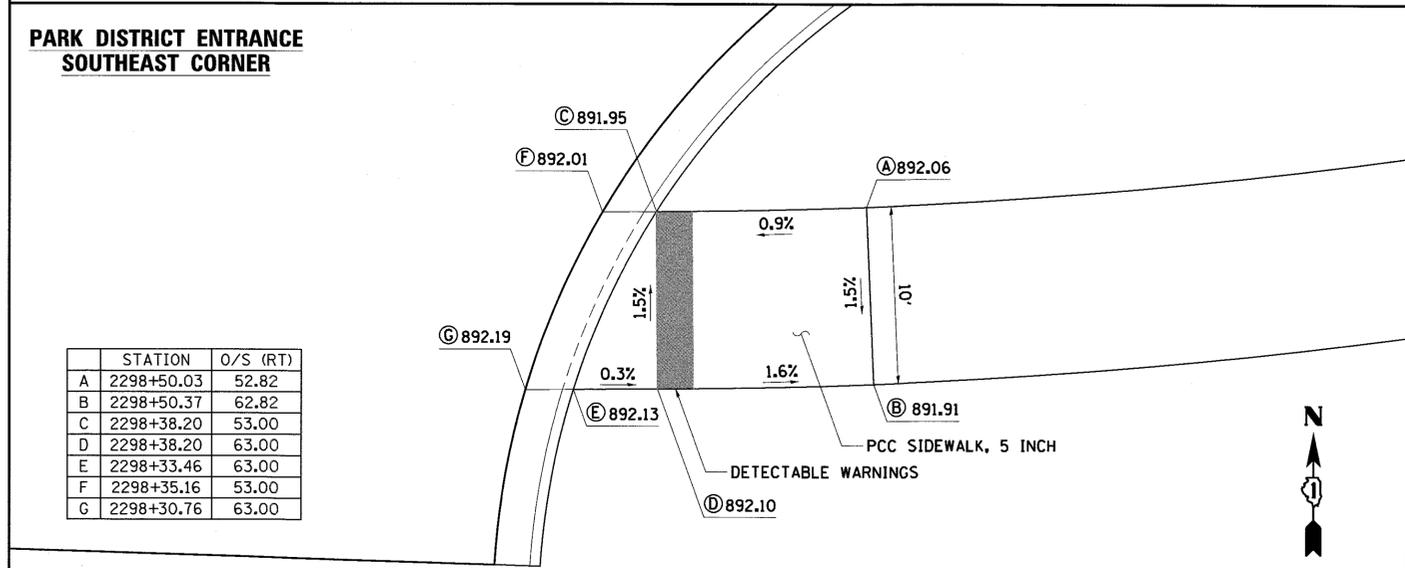

	STATION	O/S (RT)
A	2298+50.03	52.82
B	2298+50.37	62.82
C	2298+38.20	53.00
D	2298+38.20	63.00
E	2298+33.46	63.00
F	2298+35.16	53.00
G	2298+30.76	63.00

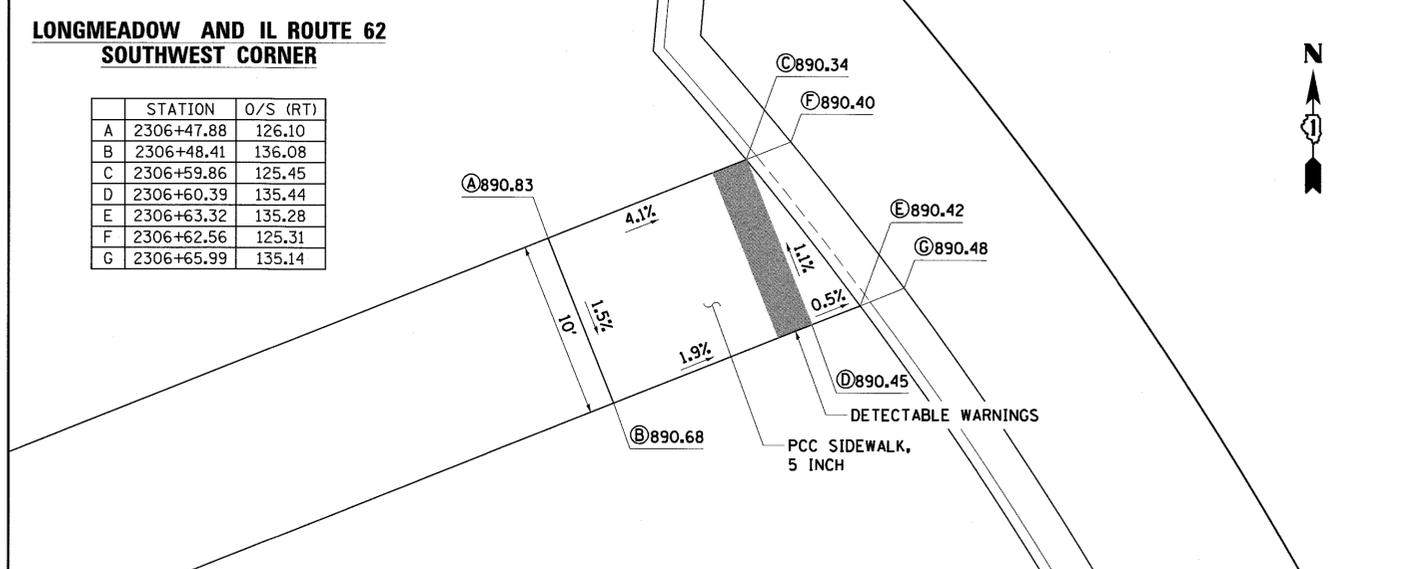

	STATION	O/S (RT)
A	2306+47.88	126.10
B	2306+48.41	136.08
C	2306+59.86	125.45
D	2306+60.39	135.44
E	2306+63.32	135.28
F	2306+62.56	125.31
G	2306+65.99	135.14

FILE NAME = 74754-shr-rdw-ds01.dwg

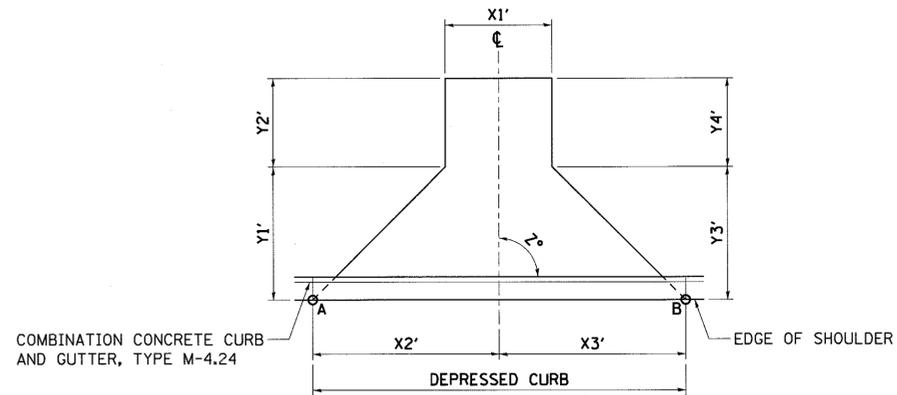

STA C	LT/RT	STA A	STA B	X1	X2	X3	Y1	Y2	Y3	Y4	Z
807+29.96	RT	807+56.53	807+13.90	12	15	15	15	13	15	13.4	96.6
821+30.59	RT	821+44.11	821+05.37	12	15	15	15	23	15	24.0	85.4
822+93.57	RT	823+13.58	822+72.03	15	15	15	15	18	15	17.7	87.9
826+18.17	LT	826+23.82	826+68.57	12	15	15	15	33	15	25.4	58.6

IL ROUTE 62 DRIVEWAYS

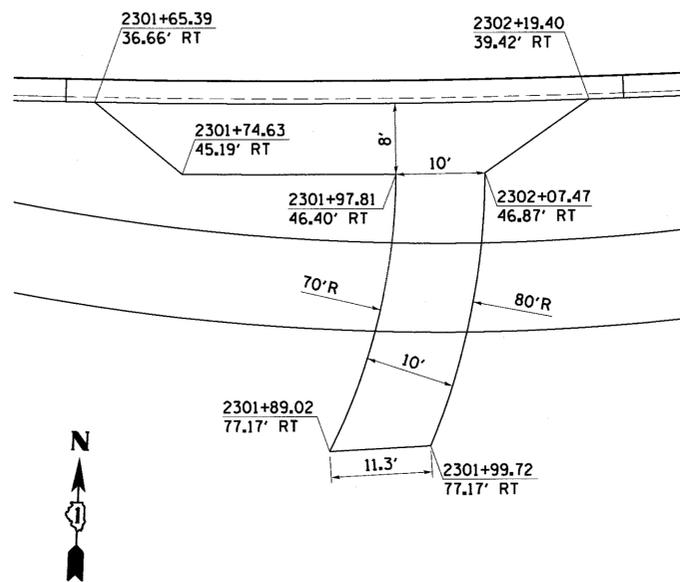

LONGMEADOW DRIVEWAY STA 2303+72.17

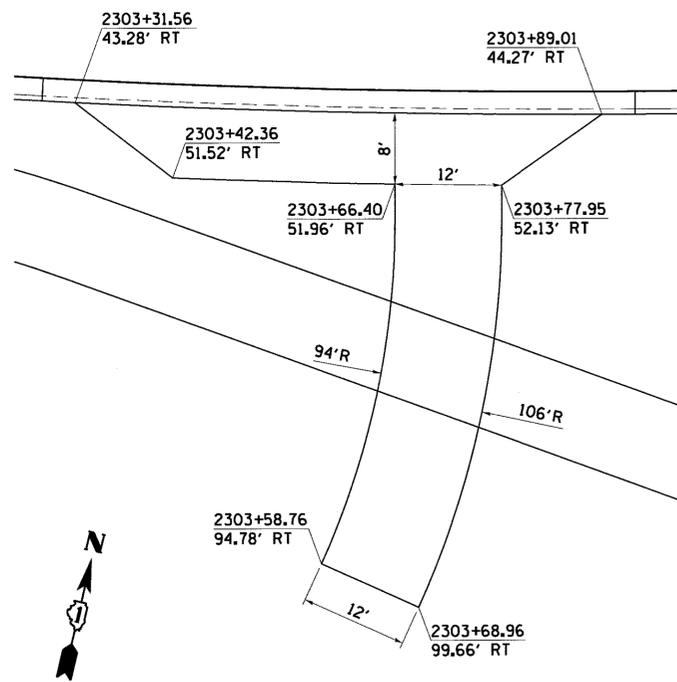

LONGMEADOW DRIVEWAY STA 2303+72.17

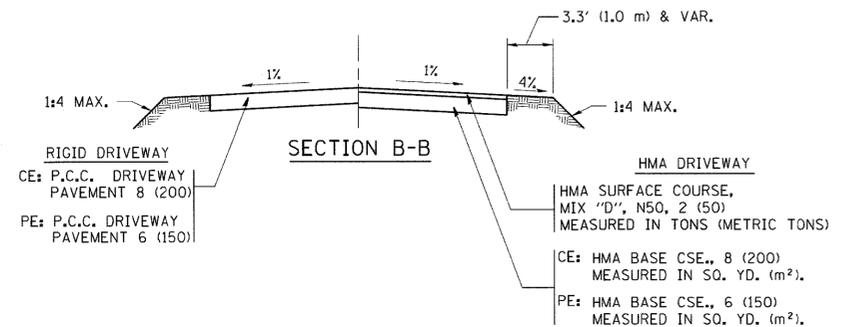
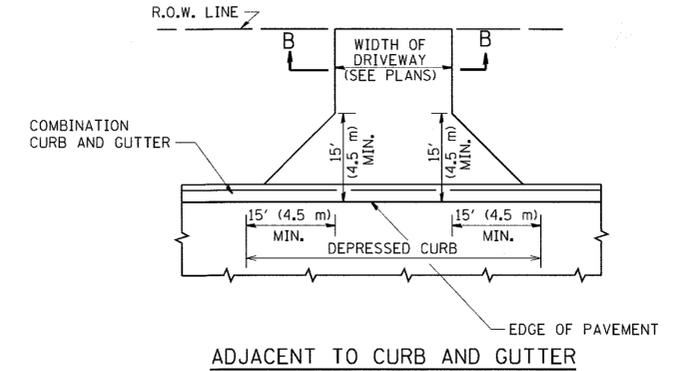
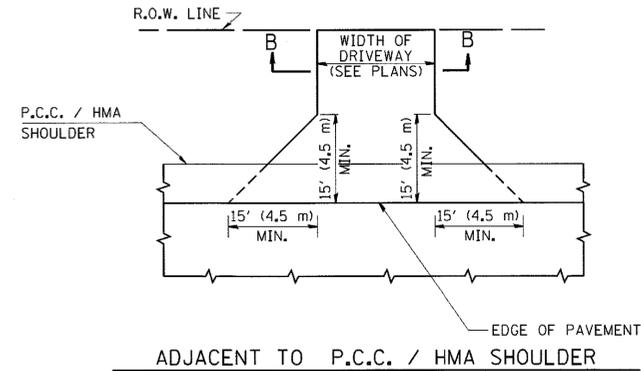

GENERAL NOTES:

DRIVEWAY SLOPES, LOCATIONS, & GEOMETRIC LAYOUT SHALL BE IN ACCORDANCE WITH THE LATEST EDITION OF THE "HANDBOOK FOR POLICY ON PERMITS FOR ACCESS DRIVEWAYS TO STATE HIGHWAYS". FOR FURTHER LAYOUT REQUIREMENTS, REFER TO ILLUSTRATIONS IN THE PERMIT HANDBOOK. DRIVEWAYS SHALL BE REPLACED IN KIND, UNLESS OTHERWISE NOTED ON THE PLANS.

COMMERCIAL DRIVEWAYS SHALL BE CONSTRUCTED WITH CONCRETE CURB, TYPE B RETURNS EXCEPT WHEN THE SIDEWALK EDGE IS 4 FEET (1.2 METERS) OR LESS FROM THE BACK OF CURB, CONSTRUCT A FLARE DRIVEWAY WITHOUT CURB.

THE RESIDENT ENGINEER SHALL CONTACT THE TRAFFIC PERMIT OFFICE AT 847/ 705-4131 FOR ANY QUESTIONS ON DRIVEWAYS SHOWN IN THE PLANS; SPECIFICALLY IN REFERENCE TO ADDITIONAL AND/OR RELOCATION/REMOVAL OF A DRIVEWAY.

COMBINATION CONCRETE CURB & GUTTER SHALL BE MEASURED STRAIGHT ACROSS THE DRIVEWAY. NO ADDITIONAL COMPENSATION WILL BE ALLOWED FOR THE CURB & GUTTER TRANSITION.

1 (25) PREFORMED EXPANSION JOINT FILLER WILL NOT BE PAID SEPARATELY, BUT SHALL BE CONSIDERED INCLUDED IN THE COST OF THE P.C.C. DRIVEWAY PAVEMENT OR P.C.C. SIDEWALK.

WHEN THE P.C.C. SIDEWALK EXTENDS THROUGH THE DRIVEWAY, THE THICKNESS OF THE SIDEWALK IN THE DRIVEWAY AREA SHALL BE THE SAME AS THE DRIVEWAY THICKNESS. SIDEWALK WILL BE PAID FOR AS P.C.C. SIDEWALK OF THE THICKNESS SPECIFIED. SIDEWALK CROSS SLOPE THRU DRIVEWAY AREA TO BE A MAXIMUM OF 1:50.

RURAL FIELD ENTRANCE (FE)

HMA SURFACE COURSE, MIX 'D', N50, 2 (50) MEASURED IN TONS (METRIC TONS)

AGGREGATE BASE CSE., TYPE B, 8 (200) MEASURED IN SQ. YD. (m²).

FILE NAME = 74754-ahtr-dwy-ds02.dgn



USER NAME = r.jiang
 DRAWN -
 CHECKED -
 DATE = 9/1/2017

DESIGNED -
 DRAWN -
 CHECKED -
 DATE = 9/5/2017

REVISED -
 REVISED -
 REVISED -
 REVISED -

STATE OF ILLINOIS
 DEPARTMENT OF TRANSPORTATION

ROADWAY DETAILS

SCALE: SHEET OF SHEETS STA. TO STA.

F.A.U. RTE.	SECTION	COUNTY	TOTAL SHEETS	SHEET NO.
2298	13-00215-30-PV	KANE	177	81
CONTRACT NO. 61D16				
ILLINOIS FED. AID PROJECT				

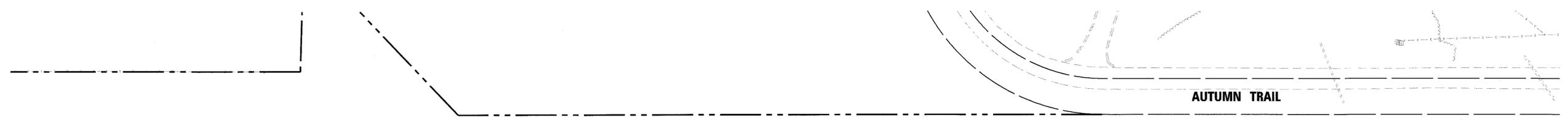
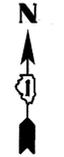

PROJECT BEGINS
STA. 2283+00.00

LONGMEADOW PARKWAY

MATCH LINE STA. 2296+50

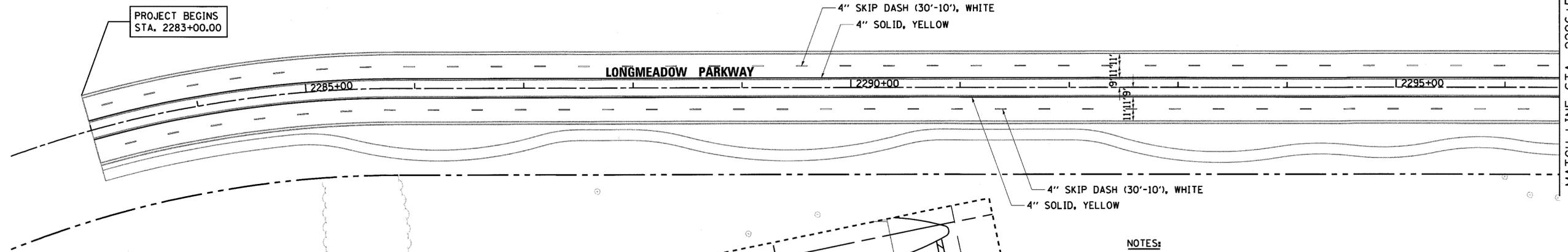

NOTES:

- 1. PAVEMENT MARKINGS ON LONGMEADOW PARKWAY SHALL BE MODIFIED URETHANE.
- 2. PAVEMENT MARKINGS ON IL ROUTE 62 SHALL BE THERMOPLASTIC.

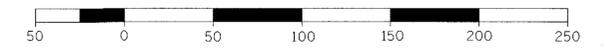
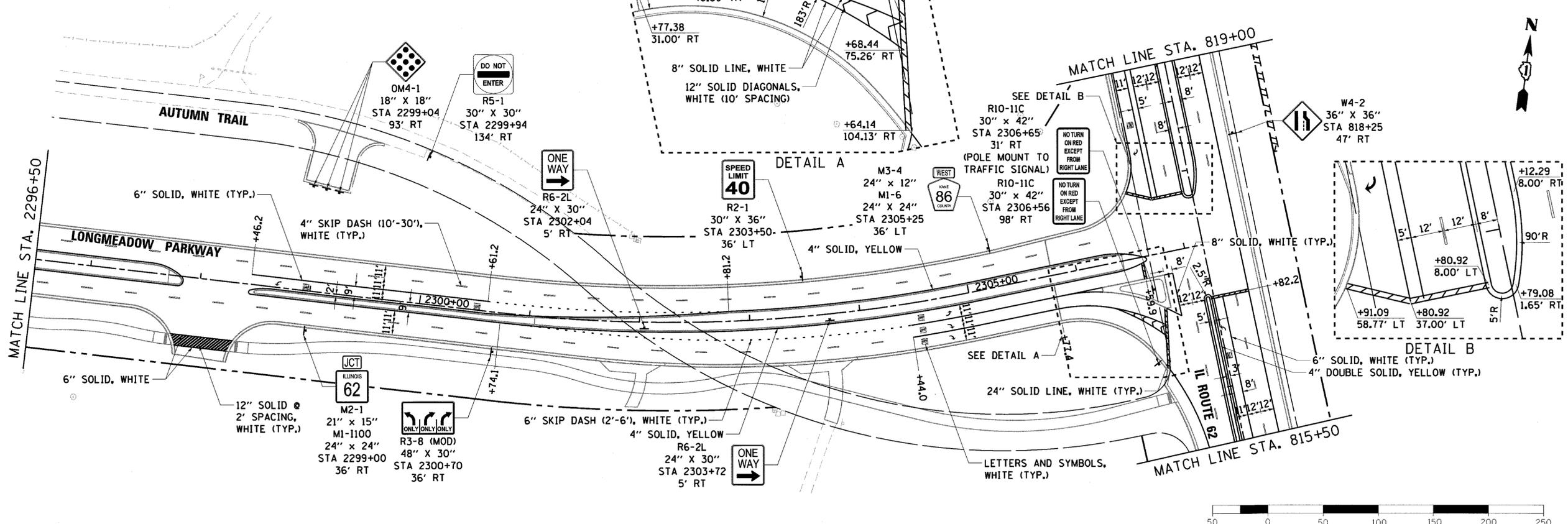
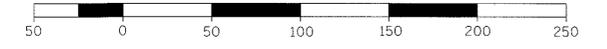

FILE NAME = 74754-ahv-pmk61.dgn



USER NAME = r.jiang	DESIGNED - RGJ	REVISED -
PLOT SCALE = 100.0000' / in.	DRAWN - RGJ	REVISED -
PLOT DATE = 9/1/2017	CHECKED - RMG	REVISED -
	DATE - 9/5/2017	REVISED -

STATE OF ILLINOIS
DEPARTMENT OF TRANSPORTATION

SIGNING AND PAVEMENT MARKING PLAN

SCALE: 1" = 50' SHEET 1 OF 3 SHEETS STA. 2283+00 TO STA. 2307+17

F.A.U. RTE. 2298	SECTION 13-00215-30-PV	COUNTY KANE	TOTAL SHEETS 177	SHEET NO. 82
				CONTRACT NO. 61D16
ILLINOIS FED. AID PROJECT				

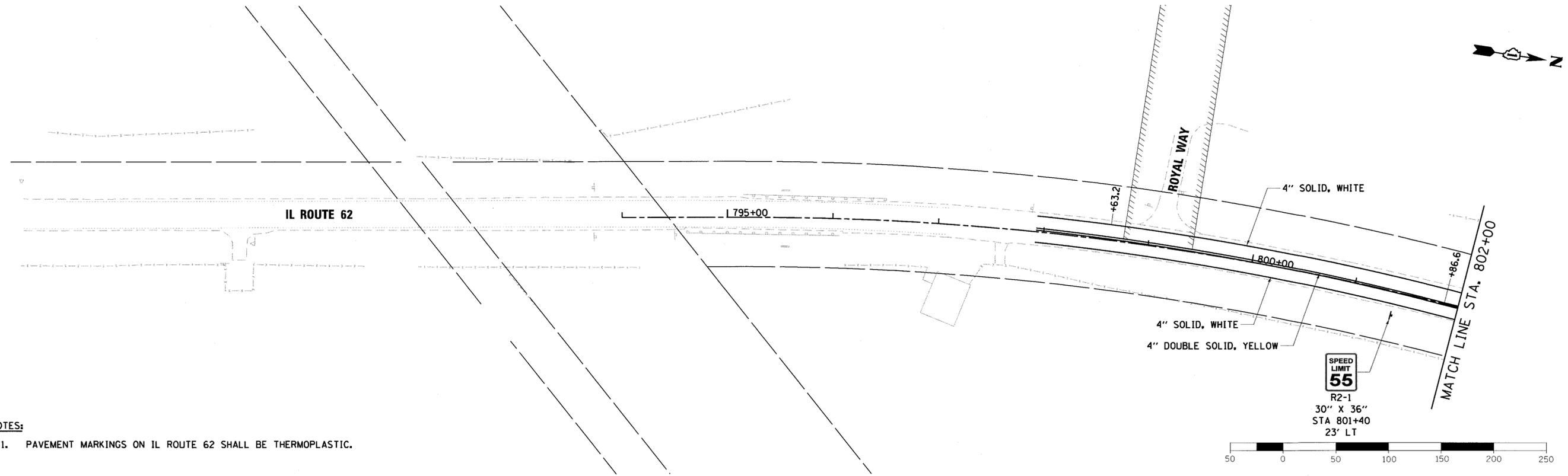

NOTES:

- PAVEMENT MARKINGS ON IL ROUTE 62 SHALL BE THERMOPLASTIC.

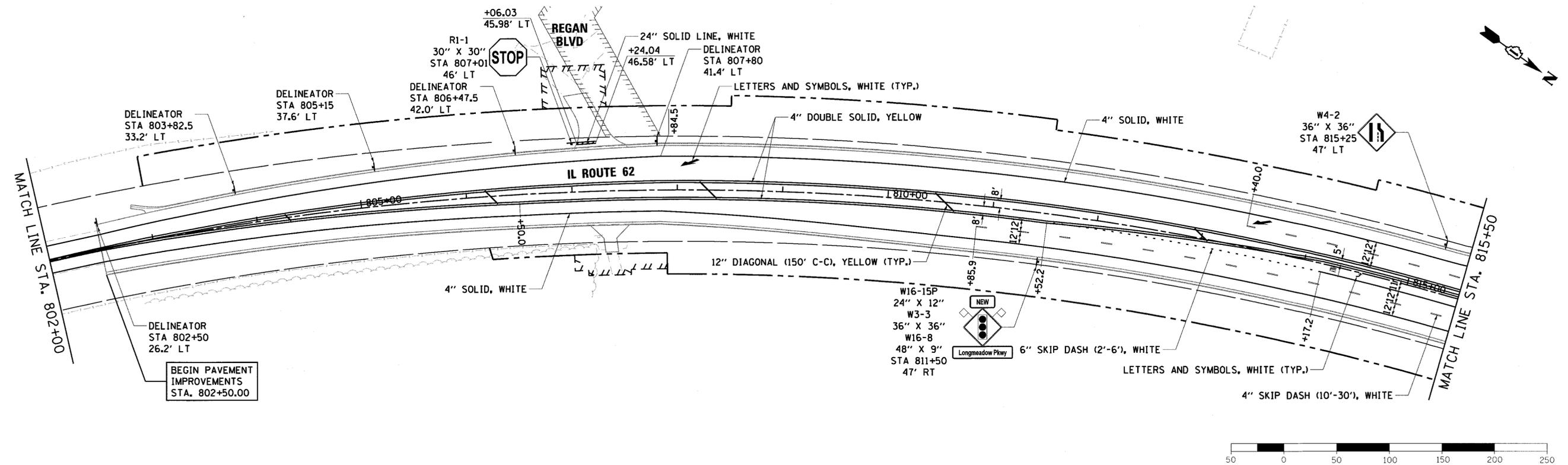
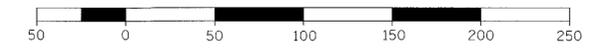

FILE NAME: 7/4/14-ah-pmk62.dgn



USER NAME = rjjang
 PLOT SCALE = 1/80,000 1/4" = 100'
 PLOT DATE = 9/1/2017

DESIGNED - RGJ
 DRAWN - RGJ
 CHECKED - RMG
 DATE - 9/5/2017

REVISED -
 REVISED -
 REVISED -
 REVISED -

**STATE OF ILLINOIS
 DEPARTMENT OF TRANSPORTATION**

SIGNING AND PAVEMENT MARKING PLAN

SCALE: 1" = 50' SHEET 2 OF 3 SHEETS STA. 794+00 TO STA. 815+50

F.A.U. RTE. 2298	SECTION 13-00215-30-PV	COUNTY KANE	TOTAL SHEETS 177	SHEET NO. 83
ILLINOIS FED. AID PROJECT			CONTRACT NO. 61D16	

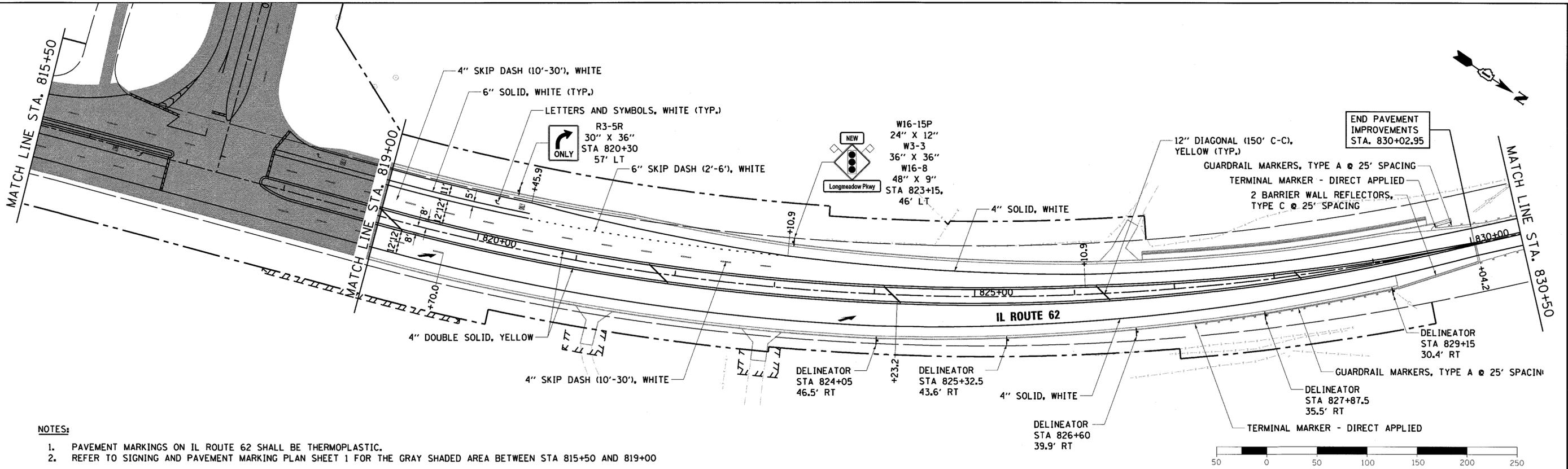

- NOTES:**
- PAVEMENT MARKINGS ON IL ROUTE 62 SHALL BE THERMOPLASTIC.
 - REFER TO SIGNING AND PAVEMENT MARKING PLAN SHEET 1 FOR THE GRAY SHADED AREA BETWEEN STA 815+50 AND 819+00

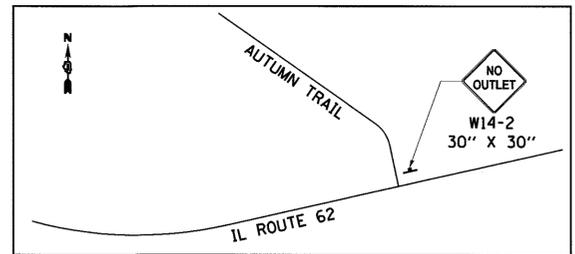
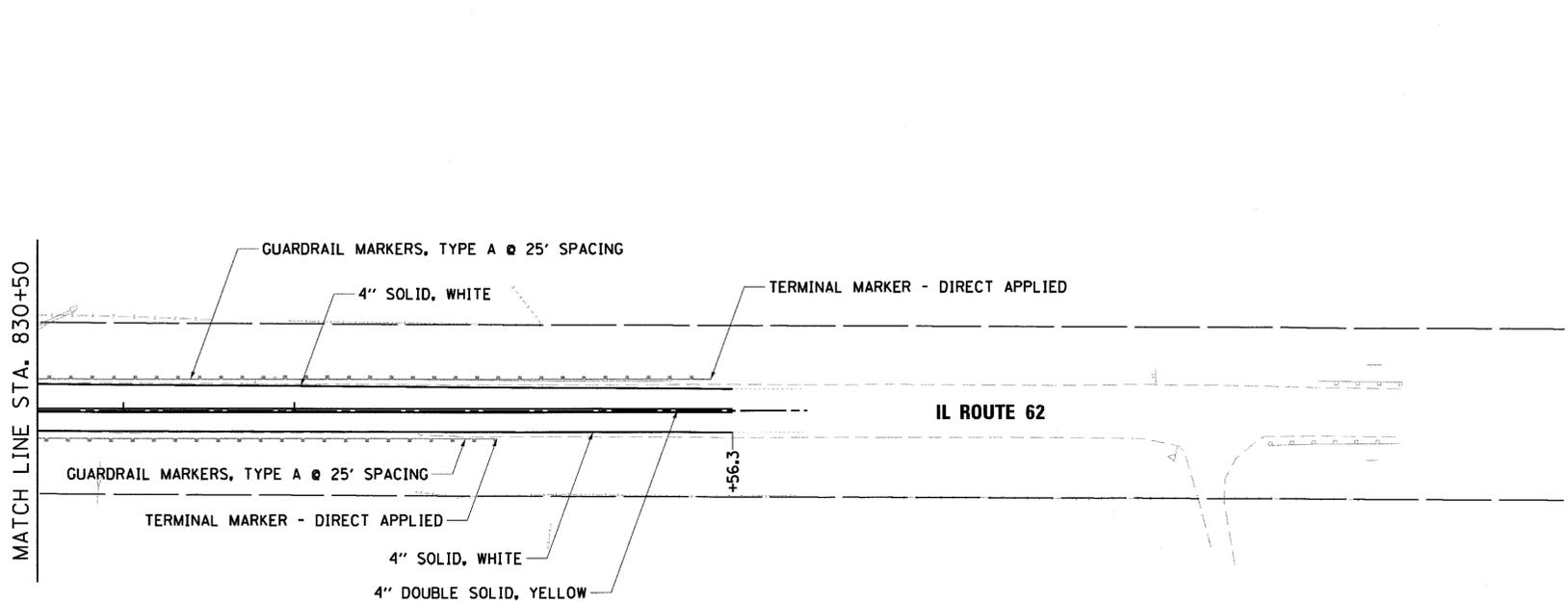

SIGNING AT NORTH AUTUMN TRAIL ENTRANCE DETAIL

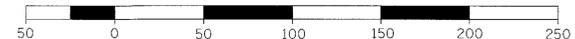

FILE NAME = 74754-ahc-pmk83.dgn



USER NAME = rjiong	DESIGNED - RGJ	REVISED -
DRAWN - RGJ	REVISIONS -	
PLLOT SCALE = 1/80.0000' / in.	CHECKED - RMG	REVISED -
PLLOT DATE = 9/1/2017	DATE - 9/5/2017	REVISED -

**STATE OF ILLINOIS
DEPARTMENT OF TRANSPORTATION**

SIGNING AND PAVEMENT MARKING PLAN

SCALE: 1" = 50' SHEET 3 OF 3 SHEETS STA. 815+50 TO STA. 835+00

F.A.J. RTE. 2298	SECTION 13-00215-30-PV	COUNTY KANE	TOTAL SHEETS 177	SHEET NO. 84
				CONTRACT NO. 61D16
ILLINOIS FED. AID PROJECT				

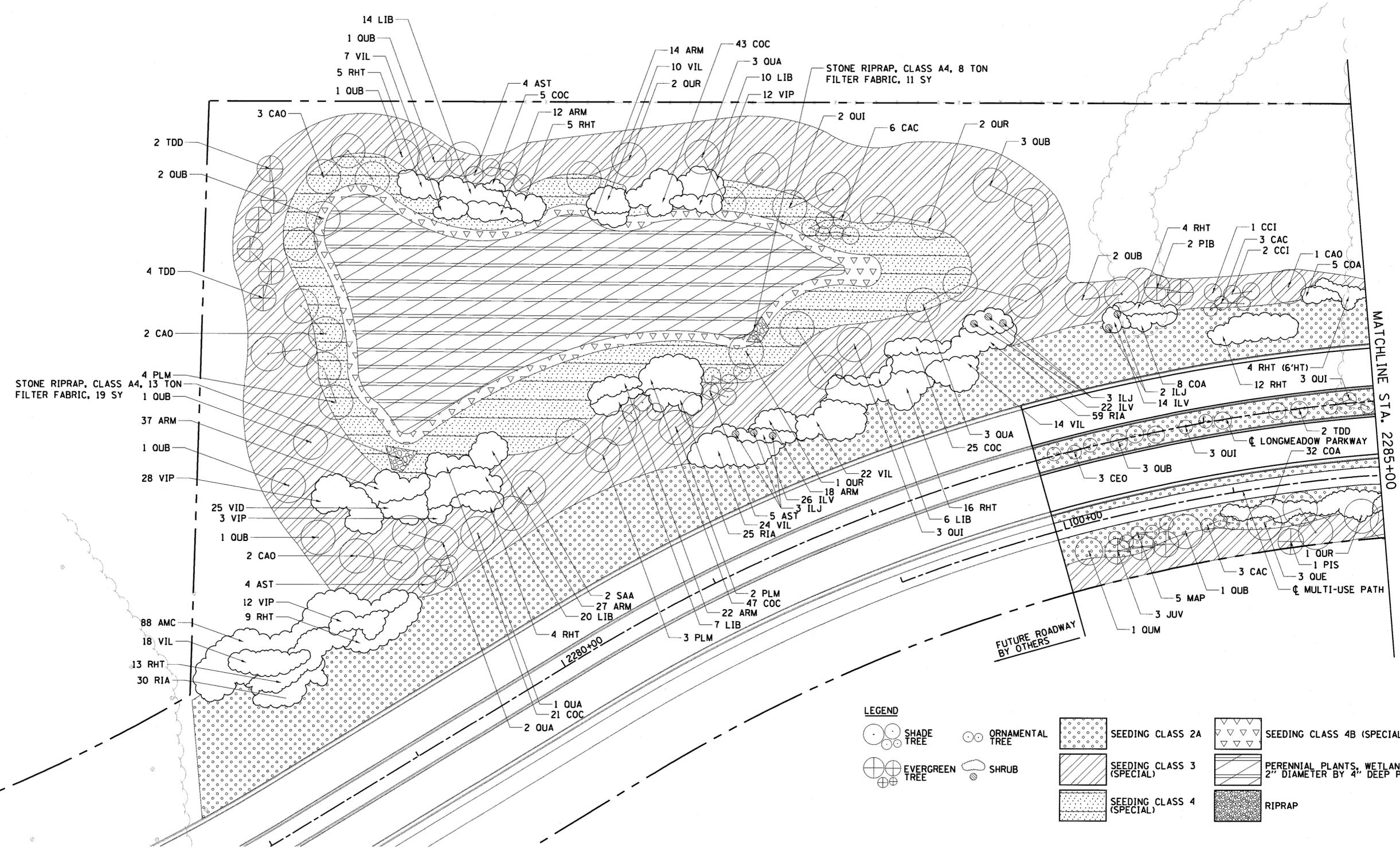

MATCHLINE STA. 2285+00

FUTURE ROADWAY BY OTHERS

LEGEND

SHADE TREE	ORNAMENTAL TREE	SEEDING CLASS 2A	SEEDING CLASS 4B (SPECIAL)
EVERGREEN TREE	SHRUB	SEEDING CLASS 3 (SPECIAL)	PERENNIAL PLANTS, WETLAND TYPE, 2" DIAMETER BY 4" DEEP PLUG
		SEEDING CLASS 4 (SPECIAL)	RIPRAP

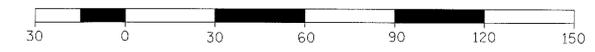

FILE NAME = 74754-rht-landscape-lm01.dgn

Altamanu Inc.
landscape architecture + urban design + planning

USER NAME = r.jiang	DESIGNED - JC	REVISED -
PLOT SCALE = 60,0000' / 1"	DRAWN - RGJ	REVISED -
PLOT DATE = 9/26/2017	CHECKED - RMG	REVISED -
	DATE - 9/5/2017	REVISED -

**STATE OF ILLINOIS
DEPARTMENT OF TRANSPORTATION**

**LANDSCAPING PLAN
LONGMEADOW PARKWAY**

SCALE: 1" = 30' SHEET 1 OF 4 SHEETS STA. 2278+00 TO STA. 2285+00

F.A.U. RTE.	SECTION	COUNTY	TOTAL SHEETS	SHEET NO.
2298	13-00215-30-PV	KANE	177	85
CONTRACT NO. 61D16				
ILLINOIS FED. AID PROJECT				

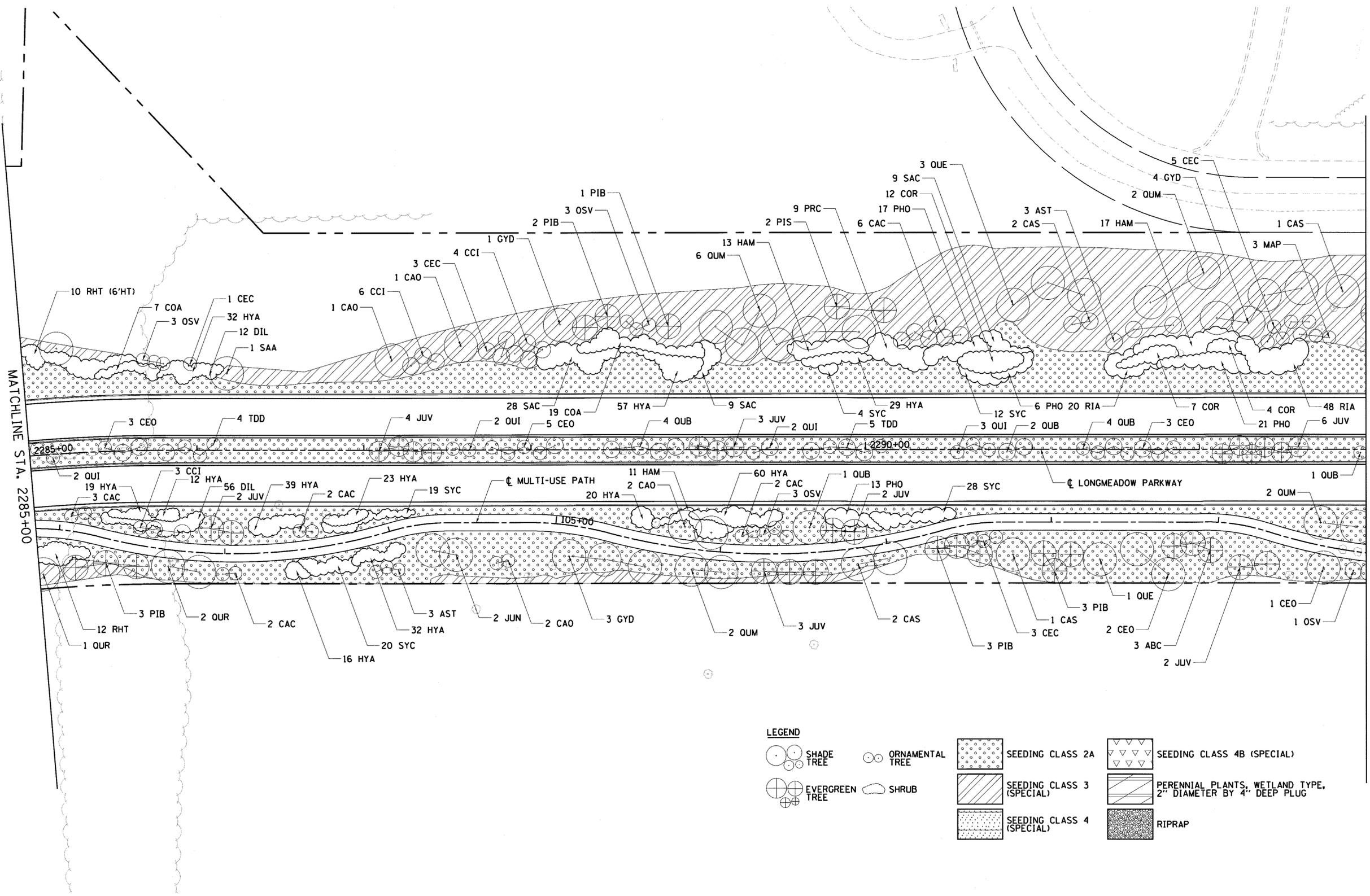

MATCHLINE STA. 2285+00

MATCH LINE STA. 2293+00

LEGEND

- SHADE TREE
- ORNAMENTAL TREE
- EVERGREEN TREE
- SHRUB
- SEEDING CLASS 2A
- SEEDING CLASS 3 (SPECIAL)
- SEEDING CLASS 4 (SPECIAL)
- SEEDING CLASS 4B (SPECIAL)
- PERENNIAL PLANTS, WETLAND TYPE, 2" DIAMETER BY 4" DEEP PLUG
- RIPRAP

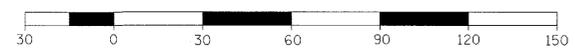

FILE NAME = 74754-ahs-1-landscape-imb2.dgn

Altamanu Inc.
landscape architecture + urban design + planning

USER NAME = rjjang	DESIGNED - JC	REVISED -
DRAWN - RGJ	REVISIONS -	
PLLOT SCALE = 60.0000' / 1"	CHECKED - RMG	REVISED -
PLLOT DATE = 9/1/2017	DATE - 9/5/2017	REVISED -

**STATE OF ILLINOIS
DEPARTMENT OF TRANSPORTATION**

**LANDSCAPING PLAN
LONGMEADOW PARKWAY**

SCALE: 1" = 30' SHEET 2 OF 4 SHEETS STA. 2285+00 TO STA. 2293+00

F.A.I. RTE.	SECTION	COUNTY	TOTAL SHEETS	SHEET NO.
2298	13-00215-30-PV	KANE	177	86
CONTRACT NO. 61D16			ILLINOIS FED. AID PROJECT	

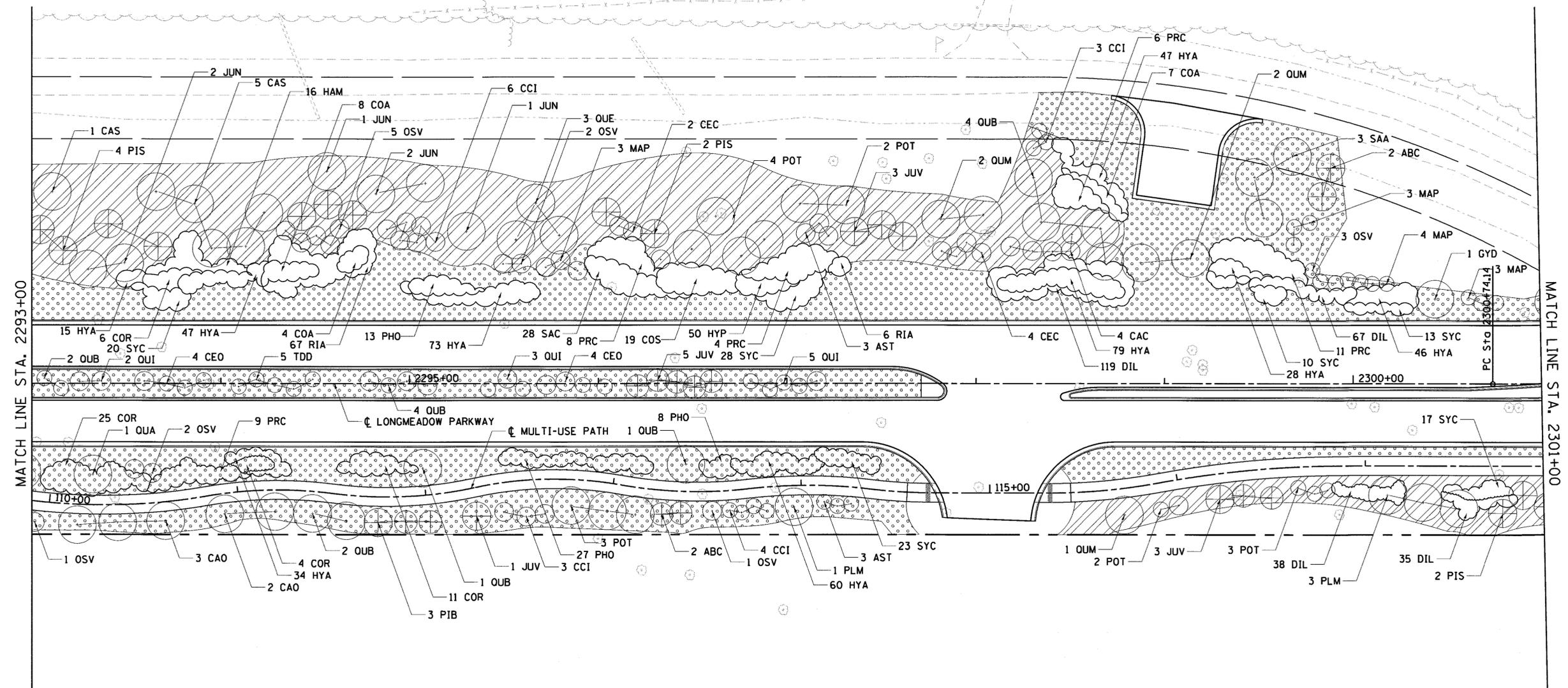
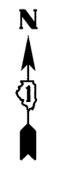

LEGEND

- SHADE TREE
- ORNAMENTAL TREE
- SEEDING CLASS 2A
- SEEDING CLASS 4B (SPECIAL)
- EVERGREEN TREE
- SHRUB
- SEEDING CLASS 3 (SPECIAL)
- PERENNIAL PLANTS, WETLAND TYPE, 2" DIAMETER BY 4" DEEP PLUG
- SEEDING CLASS 4 (SPECIAL)
- RIPRAP

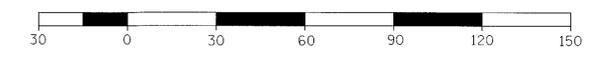

FILE NAME = 74754-ah-landscape-lm23.dgn

<p>Altamanu Inc. landscape architecture + urban design + planning</p>	USER NAME = r.jiang	DESIGNED - JC	REVISED -	<p>STATE OF ILLINOIS DEPARTMENT OF TRANSPORTATION</p>	<p>LANDSCAPING PLAN LONGMEADOW PARKWAY</p>	F.A.U. RTE. 2298	SECTION 13-00215-30-PV	COUNTY KANE	TOTAL SHEETS 177	SHEET NO. 87		
	PLLOT SCALE = 60,0000' / in.	CHECKED - RMG	REVISIED -			SCALE: 1" = 30'	SHEET 3 OF 4 SHEETS	STA. 2293+00 TO STA. 2301+00	CONTRACT NO. 61D16			
	PLLOT DATE = 9/1/2017	DATE - 9/5/2017	REVISIED -			ILLINOIS FED. AID PROJECT						

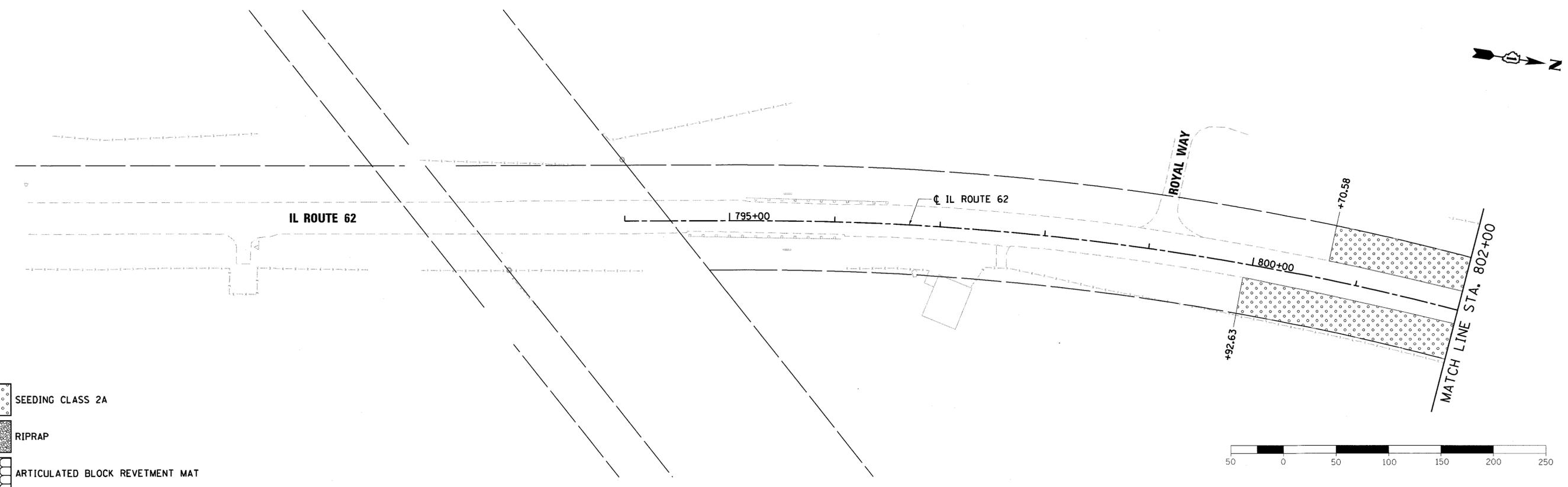
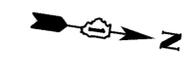

LEGEND

- SEEDING CLASS 2A
- RIPRAP
- ARTICULATED BLOCK REVETMENT MAT

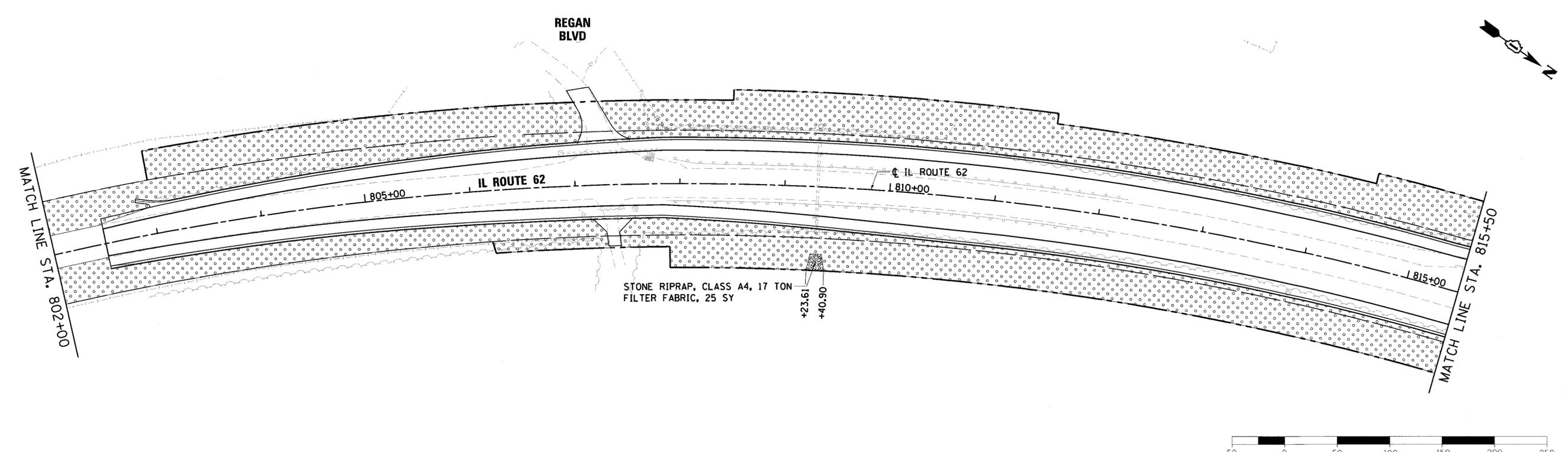
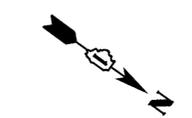

FILE NAME = 74754-ah-1-ndsp-6221.dgn



USER NAME = r.j.sang	DESIGNED - RGJ	REVISED -
	DRAWN - RGJ	REVISED -
PLOT SCALE = 100.0000' / 1in.	CHECKED - RMG	REVISED -
PLOT DATE = 9/1/2017	DATE - 9/5/2017	REVISED -

**STATE OF ILLINOIS
DEPARTMENT OF TRANSPORTATION**

**LANDSCAPING PLAN
IL ROUTE 62**

SCALE: 1" = 50' SHEET 1 OF 2 SHEETS STA. 794+00.00 TO STA. 815+50.00

F.A.U. RTE.	SECTION	COUNTY	TOTAL SHEETS	SHEET NO.
2298	13-00215-30-PV	KANE	177	89
CONTRACT NO. 61D16			ILLINOIS FED. AID PROJECT	

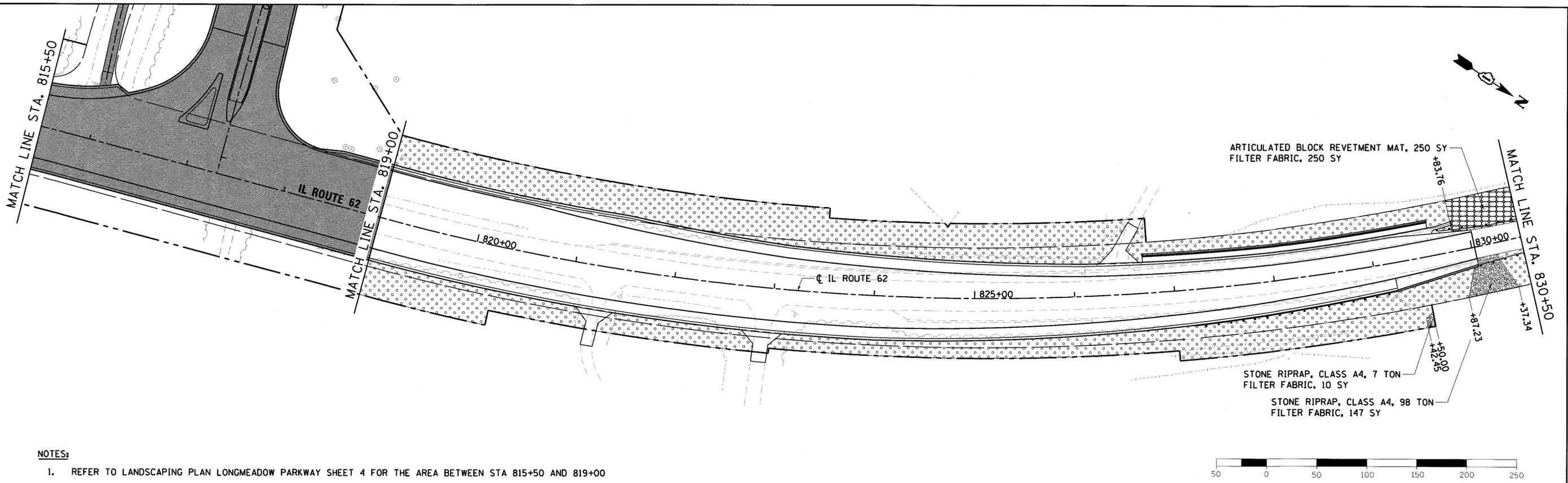

NOTES:
 1. REFER TO LANDSCAPING PLAN LONGMEADOW PARKWAY SHEET 4 FOR THE AREA BETWEEN STA 815+50 AND 819+00

LEGEND

	SEEDING CLASS 2A
	RIPRAP
	ARTICULATED BLOCK REVETMENT MAT

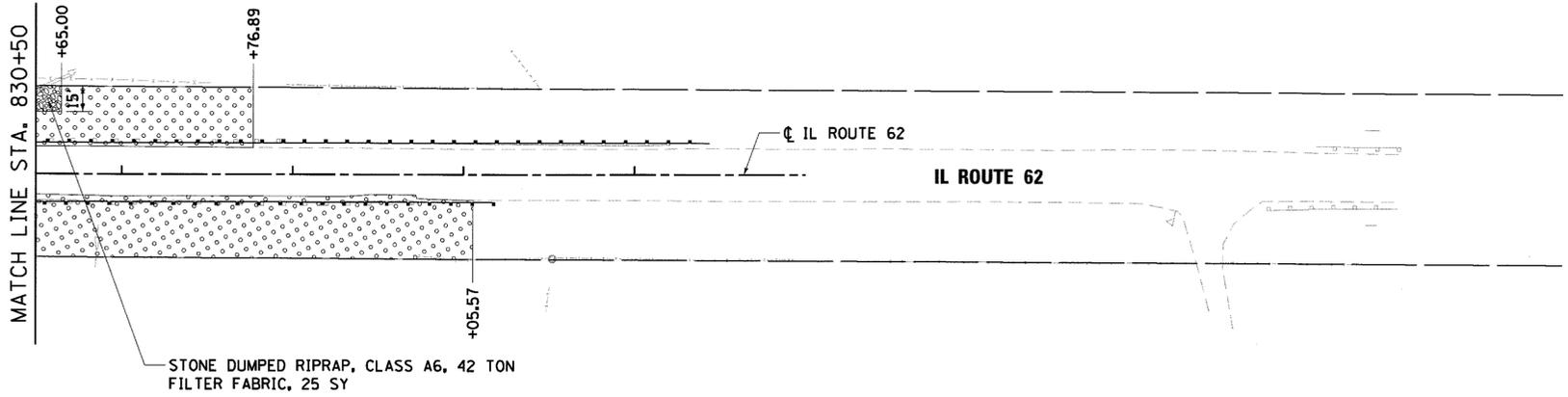

FILE NAME = 74754-ah1-Indeop-6222.dgn

	USER NAME = r.jiang	DESIGNED - RGJ	REVISED -	STATE OF ILLINOIS DEPARTMENT OF TRANSPORTATION	LANDSCAPING PLAN IL ROUTE 62			F.A.U. RTE. 2298	SECTION 13-00215-30-PV	COUNTY KANE	TOTAL SHEETS 177	SHEET NO. 90
	PLOT SCALE = 1/8" = 1' / 1/4"	CHECKED - RMG	REVISED -		SCALE: 1" = 50'	SHEET 2	OF 2 SHEETS	STA. 815+50.00	TO STA. 835+00.00	CONTRACT NO. 61D16		
	PLOT DATE = 9/1/2017	DATE = 9/5/2017	REVISED -		ILLINOIS FED. AID PROJECT							

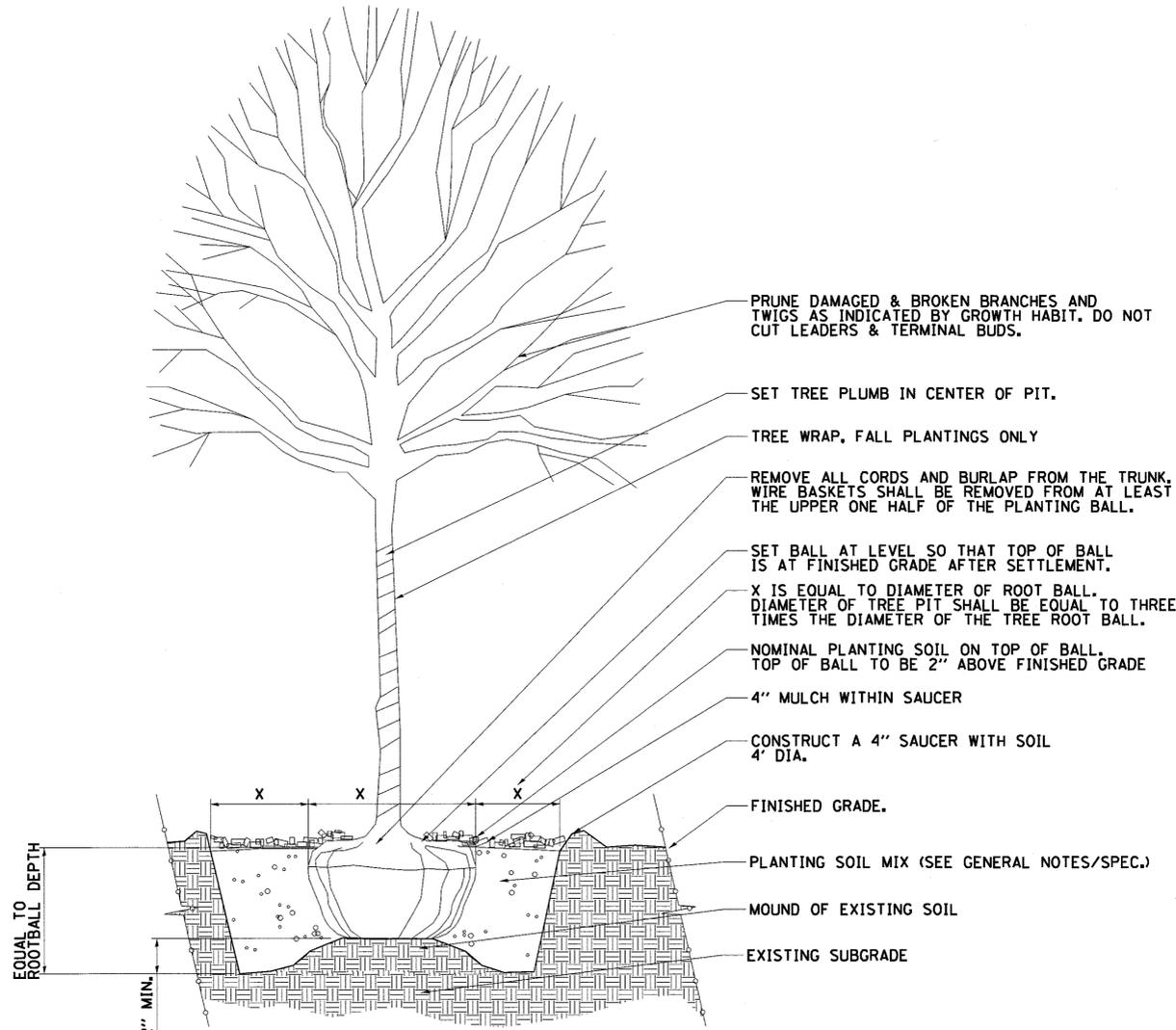

- PRUNE DAMAGED & BROKEN BRANCHES AND TWIGS AS INDICATED BY GROWTH HABIT. DO NOT CUT LEADERS & TERMINAL BUDS.
- SET TREE PLUMB IN CENTER OF PIT.
- TREE WRAP, FALL PLANTINGS ONLY
- REMOVE ALL CORDS AND BURLAP FROM THE TRUNK. WIRE BASKETS SHALL BE REMOVED FROM AT LEAST THE UPPER ONE HALF OF THE PLANTING BALL.
- SET BALL AT LEVEL SO THAT TOP OF BALL IS AT FINISHED GRADE AFTER SETTLEMENT.
- X IS EQUAL TO DIAMETER OF ROOT BALL. DIAMETER OF TREE PIT SHALL BE EQUAL TO THREE TIMES THE DIAMETER OF THE TREE ROOT BALL.
- NOMINAL PLANTING SOIL ON TOP OF BALL. TOP OF BALL TO BE 2" ABOVE FINISHED GRADE
- 4" MULCH WITHIN SAUCER
- CONSTRUCT A 4" SAUCER WITH SOIL 4' DIA.
- FINISHED GRADE.
- PLANTING SOIL MIX (SEE GENERAL NOTES/SPEC.)
- MOUND OF EXISTING SOIL
- EXISTING SUBGRADE

1 TREE PLANTING
NTS

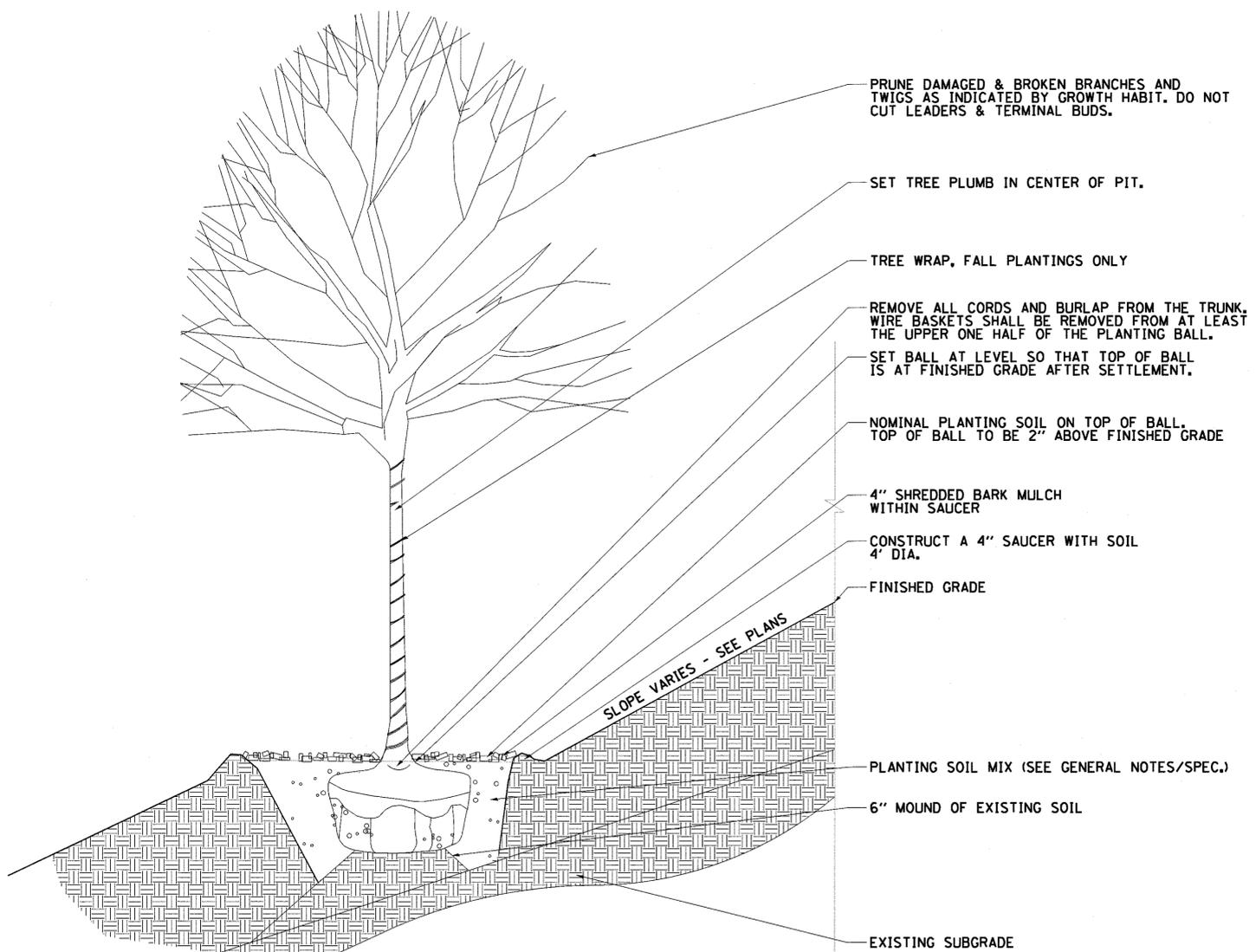

- PRUNE DAMAGED & BROKEN BRANCHES AND TWIGS AS INDICATED BY GROWTH HABIT. DO NOT CUT LEADERS & TERMINAL BUDS.
- SET TREE PLUMB IN CENTER OF PIT.
- TREE WRAP, FALL PLANTINGS ONLY
- REMOVE ALL CORDS AND BURLAP FROM THE TRUNK. WIRE BASKETS SHALL BE REMOVED FROM AT LEAST THE UPPER ONE HALF OF THE PLANTING BALL.
- SET BALL AT LEVEL SO THAT TOP OF BALL IS AT FINISHED GRADE AFTER SETTLEMENT.
- NOMINAL PLANTING SOIL ON TOP OF BALL. TOP OF BALL TO BE 2" ABOVE FINISHED GRADE
- 4" SHREDDED BARK MULCH WITHIN SAUCER
- CONSTRUCT A 4" SAUCER WITH SOIL 4' DIA.
- FINISHED GRADE
- SLOPE VARIES - SEE PLANS
- PLANTING SOIL MIX (SEE GENERAL NOTES/SPEC.)
- 6" MOUND OF EXISTING SOIL
- EXISTING SUBGRADE

3 TREE PLANTING ON SLOPE
NTS

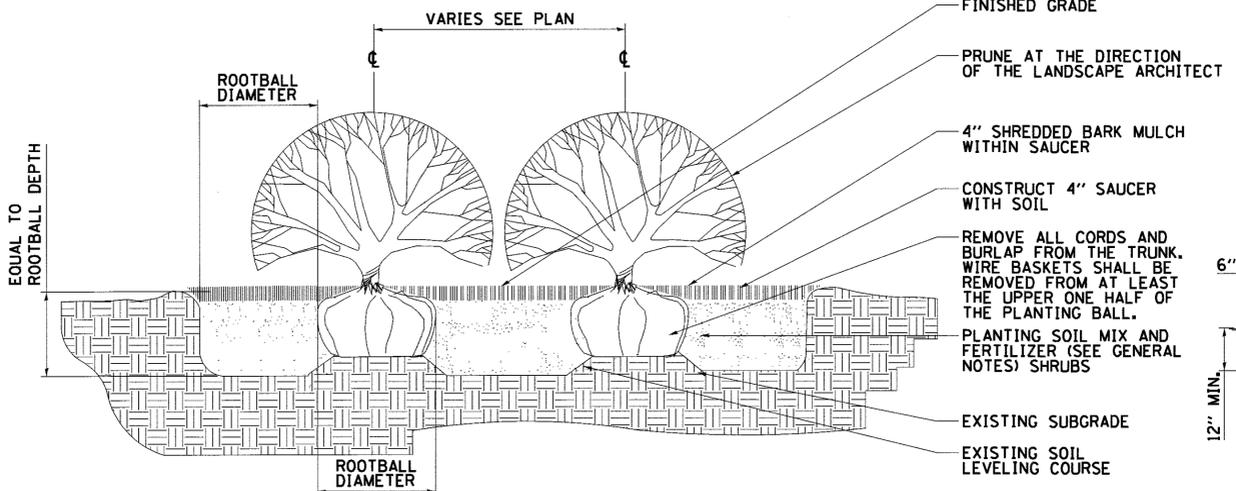

- FINISHED GRADE
- PRUNE AT THE DIRECTION OF THE LANDSCAPE ARCHITECT
- 4" SHREDDED BARK MULCH WITHIN SAUCER
- CONSTRUCT 4" SAUCER WITH SOIL
- REMOVE ALL CORDS AND BURLAP FROM THE TRUNK. WIRE BASKETS SHALL BE REMOVED FROM AT LEAST THE UPPER ONE HALF OF THE PLANTING BALL.
- PLANTING SOIL MIX AND FERTILIZER (SEE GENERAL NOTES) SHRUBS
- EXISTING SUBGRADE
- EXISTING SOIL LEVELING COURSE

2 SHRUB PLANTING
NTS

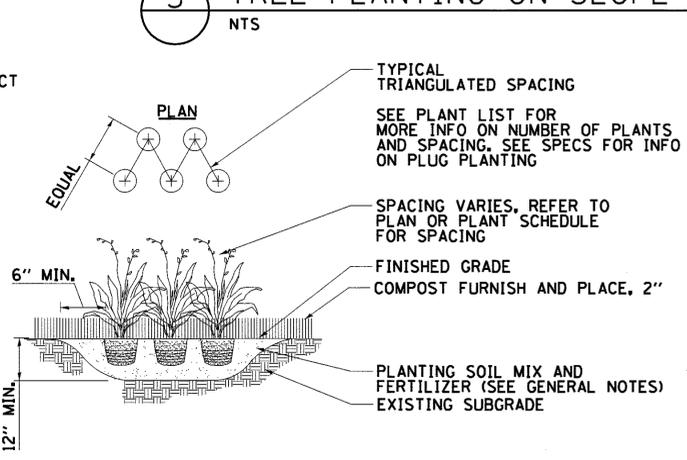

- TYPICAL TRIANGULATED SPACING
- SEE PLANT LIST FOR MORE INFO ON NUMBER OF PLANTS AND SPACING. SEE SPECS FOR INFO ON PLUG PLANTING
- SPACING VARIES, REFER TO PLAN OR PLANT SCHEDULE FOR SPACING
- FINISHED GRADE
- COMPOST FURNISH AND PLACE, 2"
- PLANTING SOIL MIX AND FERTILIZER (SEE GENERAL NOTES) EXISTING SUBGRADE

4 PLUG AND PERENNIAL PLANTING
NTS

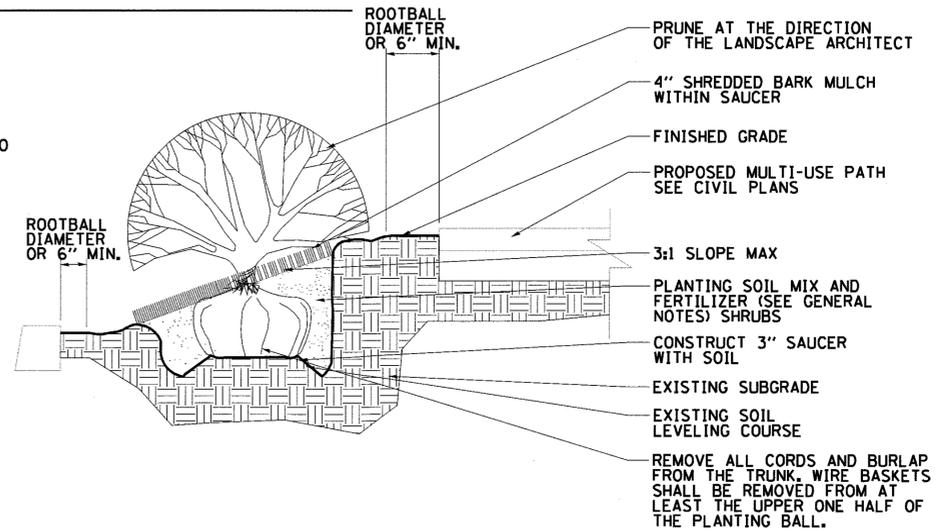

- PRUNE AT THE DIRECTION OF THE LANDSCAPE ARCHITECT
- 4" SHREDDED BARK MULCH WITHIN SAUCER
- FINISHED GRADE
- PROPOSED MULTI-USE PATH SEE CIVIL PLANS
- 3:1 SLOPE MAX
- PLANTING SOIL MIX AND FERTILIZER (SEE GENERAL NOTES) SHRUBS
- CONSTRUCT 3" SAUCER WITH SOIL
- EXISTING SUBGRADE
- EXISTING SOIL LEVELING COURSE
- REMOVE ALL CORDS AND BURLAP FROM THE TRUNK. WIRE BASKETS SHALL BE REMOVED FROM AT LEAST THE UPPER ONE HALF OF THE PLANTING BALL.

5 SHRUB PLANTING ON SLOPE
NTS

FILE NAME = 74754-ah-1-landscape-det1.dgn

USER NAME = r.jiang	DESIGNED - JC	REVISED -
PLOT SCALE = 2,0000' / 1" =	DRAWN - JC	REVISED -
PLOT DATE = 9/26/2017	CHECKED - RMG	REVISED -
	DATE - 9/5/2017	REVISED -

F.A.U. RTE. 2298	SECTION 13-00215-30-PV	COUNTY KANE	TOTAL SHEETS 177	SHEET NO. 91
CONTRACT NO. 61D16				
ILLINOIS FED. AID PROJECT				

LANDSCAPING GENERAL NOTES

- THE CONTRACTOR SHALL AVOID ALL EXISTING UTILITIES (UNDERGROUND AND OVERHEAD) WHERE APPLICABLE. FIELD ADJUSTMENTS RECOMMENDED BY THE CONTRACTOR AND INTENDED TO AVOID DISTURBING ANY SUCH UTILITIES MUST BE APPROVED BY THE ENGINEER AND LANDSCAPE ARCHITECT PRIOR TO INSTALLATION OF WORK. NEITHER THE OWNER NOR THE LANDSCAPE ARCHITECT ASSUME ANY RESPONSIBILITY WHATSOEVER IN RESPECT TO THE CONTRACTORS ACCURACY IN LOCATING THE INDICATED PLANT MATERIAL.
- ALL PLANT MATERIALS SHALL CONFORM TO THE LATEST EDITION OF THE AMERICAN STANDARD FOR NURSERY STOCK AS PUBLISHED BY THE AMERICAN NURSERY AND LANDSCAPE ASSOCIATION, 230 SOUTHERN BUILDING, WASHINGTON DC 20005 (ANSI Z60.1).
- THE CONTRACTOR SHALL PLANT TREES AND SHRUBS AFTER THE FINAL GRADES HAVE BEEN ESTABLISHED AND PRIOR TO SEEDING.
- PRUNE BROKEN OR CROSS BRANCHING PLANTING WHERE REQUIRED. DO NOT REMOVE LEADERS.
- FOR TREES PLANTED IN TURF AREAS, PROVIDE 4'-0" DIAMETER X 4 INCH THICK MULCH RING WITH A SPADE EDGE. REMOVE EXISTING TURF WHERE REQUIRED. THIS WORK IS INCLUDED IN THE COST OF THE TREE PLANTING SCOPE OF WORK AND AT NO ADDITIONAL COST.
- ALL PLANT MATERIALS SHALL BE INSTALLED IN PLANTING AREAS IN ACCORDANCE WITH THE DRAWINGS AND SPECIFICATIONS. ALL PLANTING AREAS FOUND TO BE NON-COMPLIANT SHALL BE REMOVED AND REPLANTED BY THE CONTRACTOR AT NO ADDITIONAL COST.
- THE LANDSCAPE ARCHITECT OR THE ENGINEER RESERVES THE RIGHT TO REJECT PLANTING MATERIAL ON SITE WHETHER STOCK-PILED OR PLANTED IN PLACE. REJECTED MATERIAL SHALL BE IMMEDIATELY REMOVED FROM THE SITE AND REPLACED WITH ACCEPTABLE PLANT MATERIAL AT NO ADDITIONAL COST.
- AN APPROVED PRE-EMERGENT HERBICIDE SHALL BE APPLIED IN ALL PLANTING BEDS AT THE RATE SPECIFIED AND RECOMMENDED BY THE MANUFACTURE FOR EACH PLANT VARIETY. SEE SPECIFICATIONS.
- THE CONTRACTOR SHALL PROVIDE A SPADE EDGE WHERE PLANTING BEDS MEET TURF AREAS INDICATED ON PLANS. PROVIDE MULCH AT ALL SHRUB BEDS TO LIMIT LINES INDICATED ON THE DRAWINGS. THE CONTRACTOR SHALL FURNISH AND INSTALL A 3 INCH LAYER OF ORGANIC FIBER MATERIAL UNDER ALL TREE PLANTING AND SHRUB BEDS. THE CONTRACTOR SHALL INCLUDE SAMPLES OF SUCH MATERIAL AS PART OF THE REQUIRED SHOP DRAWING SUBMITTAL PROCESS. SEE THE PROJECT SPECIFICATIONS FOR ADDITIONAL REQUIREMENTS.
- THE CONTRACTOR SHALL KEEP ALL PAVEMENT SURFACES AND WORK AREAS CLEAN. EACH TRADE ON THE SITE WILL BE REQUIRED TO CLEAN AND DISCARD ALL CONSTRUCTION RELATED DEBRIS FROM THE WORK AREA AT THE END OF EACH DAY.
- THE LANDSCAPE CONTRACTOR SHALL PROTECT ALL WORK SURFACES FROM DAMAGES BY OTHERS UNTIL HIS WORK IS COMPLETE AND ACCEPTED BY THE ENGINEER.
- ALL PLANT MATERIAL SHALL BE FULLY GUARANTEED FOR A PERIOD OF NOT LESS THAN ONE YEAR AFTER THE DATE OF ACCEPTANCE. UNHEALTHY OR EXPIRED PLANT STOCK SHALL BE REPLACED AS SOON AS CONDITIONS PERMIT AT NO ADDITIONAL COST.
- SUBSTITUTIONS OF PLANT MATERIAL DUE TO AVAILABILITY OF MATERIALS SPECIFIED SHALL BE APPROVED BY THE ENGINEER AND COORDINATED WITH THE LANDSCAPE ARCHITECT. ALL SUBSTITUTED PLANT MATERIALS SHALL BE EQUAL TO OR LARGER THAN THE ITEMS SPECIFIED ON THE PLANT LIST.

CLASS 3 (SPECIAL) Seed Mix		
Botanical Name	Common Name	Pure Live Seed LB/Acre
Native Grasses:		
<i>Bouteloua curtipendula</i>	Side Oats Grama	10.00
<i>Elymus canadensis</i>	Canada Wild Rye	5.00
<i>Schizachyrium scoparium</i>	Little Bluestem	10.00
	Total	25.00
Temporary Cover:		
<i>Avena sativa (nov. 1 to May 31)</i>	Annual Oat	30.00
	Total	30.00
OR		
<i>Lolium multiflorum (June 1 to Oct. 31)</i>	Annual Rye	30.00
	Total	30.00
Native Forbs:		
<i>Asclepias tuberosa</i>	Butterfly Weed	0.10
<i>Asclepias verticillata</i>	Whorled Milkweed	0.25
<i>Astragalus canadensis</i>	Canada Milk Vetch	0.25
<i>Baptisia leucantha</i>	White Wild Indigo	0.10
<i>Coreopsis lanceolata</i>	Sand Coreopsis	0.25
<i>Dalea candida</i>	White Prairie Clover	0.25
<i>Dalea purpurea</i>	Purple Prairie Clover	0.25
<i>Monarda fistulosa</i>	Wild Bergamot	0.25
<i>Rudbeckia hirta</i>	Black-Eyed Susan	0.50
<i>Symphotrichum oolentangiensis</i>	Sky Blue Aster	0.10
<i>Symphotrichum novae-angliae</i>	New England Aster	0.25
<i>Verbena stricta</i>	Hoary Vervain	0.25
	Total	2.80

CLASS 4 (SPECIAL) Seed Mix		
Botanical Name	Common Name	Pure Live Seed LB/Acre
Permanent Grasses:		
<i>Andropogon gerardii</i>	Big Bluestem	4.00
<i>Bouteloua curtipendula</i>	Side Oats Grama	5.00
<i>Elymus canadensis</i>	Canada Wild Rye	3.00
<i>Panicum virgatum</i>	Switch Grass	3.00
<i>Schizachyrium scoparium</i>	Little Bluestem	5.00
<i>Sorghastrum nutans</i>	Indian Grass	2.00
	Total	22.00
Temporary Cover:		
<i>Avena sativa (nov. 1 to May 31)</i>	Annual Oat	30.00
	Total	30.00
OR		
<i>Lolium multiflorum (June 1 to Oct. 31)</i>	Annual Rye	30.00
	Total	30.00
Forbs:		
<i>Asclepias syriaca</i>	Common Milkweed	0.25
<i>Dalea candida</i>	White Prairie Clover	0.10
<i>Dalea purpurea</i>	Purple Prairie Clover	0.10
<i>Desmodium illinoense</i>	Illinois Tick Trefoil	0.25
<i>Heliopsis helianthoides</i>	Ox-eye Sunflower	0.25
<i>Monarda fistulosa</i>	Wild Bergamot	0.25
<i>Penstemon digitalis</i>	Foxglove Beardtongue	0.25
<i>Ratibida pinnata</i>	Yellow Coneflower	0.50
<i>Rudbeckia hirta</i>	Black-Eyed Susan	0.50
<i>Solidago rigida</i>	Stiff Goldenrod	0.25
<i>Symphotrichum novae-angliae</i>	New England Aster	0.25
	Total	2.95

CLASS 4B (SPECIAL) Seed Mix		
Botanical Name	Common Name	Pure Live Seed LB/Acre
Native Grasses/Sedges:		
<i>Andropogon gerardii</i>	Big Bluestem	3.00
<i>Carex vulpinoidea</i>	Brown Fox Sedge	0.25
<i>Elymus virginicus</i>	Virginia Wild Rye	2.00
<i>Glyceria striata</i>	Fowl Manna Grass	0.25
<i>Juncus torreyi</i>	Torrey's Rush	0.25
<i>Leersia oryzoides</i>	Rice Cut Grass	0.25
<i>Panicum virgatum</i>	Switch Grass	3.00
<i>Scirpus atrovirens</i>	Dark Green Rush	0.25
	Total	9.25
Temporary Cover:		
<i>Avena sativa (nov. 1 to May 31)</i>	Annual Oat	30.00
	Total	30.00
OR		
<i>Lolium multiflorum (June 1 to Oct. 31)</i>	Annual Rye	30.00
	Total	30.00
Forbs:		
<i>Asclepias incarnata</i>	Swamp Milkweed	0.25
<i>Eupatorium perfoliatum</i>	Common Boneset	0.25
<i>Lycopus americanus</i>	Common Water Horehou	0.15
<i>Penthorum sedoides</i>	Ditch Stonecrop	0.15
<i>Rudbeckia laciniata</i>	Wild Golden Glow	0.25
<i>Silphium perfoliatum</i>	Cup Plant	0.25
<i>Verbena hastata</i>	Blue Vervain	0.25
<i>Verbesina alternifolia</i>	Wingstem	0.25
<i>Zizia aurea</i>	Golden Alexanders	0.25
	Total	2.05

MASTER PLANT LIST

Plant Code	Qty	Size	Botanic Name	Common Name	Form	Mature Size	Spacing	Comments
Evergreen Trees								
ABC	7	7' ht.	<i>Abies concolor</i>	White Fir	BB	70' ht	See Plans	
JUV	47	6' ht.	<i>Juniperus virginiana</i>	Eastern Redcedar	BB	20' ht	See Plans	
PIB	19	7' ht.	<i>Pinus nigra</i>	Austrian Pine	BB	60' ht	See Plans	
PIS	12	7' ht.	<i>Pinus strobus</i>	Eastern White Pine	BB	80' ht	See Plans	

Shade Trees								
CAO	20	2.0" cal	<i>Carya ovata</i>	Shagbark Hickory	BB	90' ht	See Plans	
CAS	12	2.0" cal	<i>Catalpa speciosa</i>	Northern Catalpa	BB	70' ht	See Plans	
CEO	31	2.0" cal	<i>Celtis occidentalis</i>	Common Hackberry	BB	60' ht	See Plans	
GYD	9	2.0" cal	<i>Gymnocladus dioica</i>	Kentucky Coffee Tree	BB	80' ht	See Plans	
JUN	8	2.0" cal	<i>Juglans nigra</i>	Eastern Black Walnut	BB	100' ht	See Plans	Setback From Road
PLM	13	2.0" cal	<i>Platanus acerifolia 'Morton Circle'</i>	Exclamation London Planetree	BB	100' ht	See Plans	
POT	14	2.0" cal	<i>Populus tremuloides</i>	Quaking Aspen	BB	50' ht	See Plans	
QUB	58	2.0" cal	<i>Quercus bicolor</i>	Swamp White Oak	BB	60' ht	See Plans	Spring Dig Only
QUR	36	2.0" cal	<i>Quercus rubra</i>	Northern Red Oak	BB	75' ht	See Plans	Spring Dig Only
QUI	38	2.0" cal	<i>Quercus imbricaria</i>	Shingle Oak	BB	40' ht	See Plans	Spring Dig Only
QUM	26	2.0" cal	<i>Quercus macrocarpa</i>	Bur Oak	BB	80' ht	See Plans	Spring Dig Only
QUA	10	2.0" cal	<i>Quercus alba</i>	White Oak	BB	80' ht	See Plans	Spring Dig Only
SAA	6	2.0" cal	<i>Salix alba var. tristis</i>	Golden Niobe Weeping Willow	BB	75' ft	See Plans	
TDD	22	2.0" cal	<i>Taxodium Distichum</i>	Common Bald Cypress	BB	70' ht	See Plans	

Understory Trees								
AST	25	#5 Cont	<i>Asimina triloba</i>	Pawpaw	CG	25' ht	See Plans	
CAC	30	2" cal	<i>Carpinus caroliniana</i>	American Hornbeam	BB	25' ht	See Plans	Spring Dig Only
CEC	24	#5 Cont	<i>Cercis canadensis</i>	Eastern Redbud	CG	30' ht	See Plans	
CCI	32	6' ht.	<i>Crataegus crusgalli var. inermis</i>	Thornless Cockspur Hawthorn	BB	30' ht	See Plans	
MAP	32	7' ht.	<i>Malus 'Donald Wyman'</i>	Donald Wyman Crabapple	BB	20' ht	See Plans	
OSV	27	8' ht.	<i>Ostrya virginiana</i>	Eastern Hop Hornbeam	BB	20' ht	See Plans	Spring Dig Only

Shrubs								
PRC	47	#3 Cont	<i>Prunus americana</i>	American Plum	CG	8'-10' ht x 6'-8' w	8'	
RHT	14	#5 Cont	<i>Rhus typhina</i>	Staghorn Sumac	CG	8'-10' ht x 8'-10' w	8'	
AMC	88	#3 Cont	<i>Amorpha fruticosa</i>	Indigo Bush	CG	2'-3' ht x 2'-2.5' w	5'	
ARM	130	#5 Cont	<i>Aronia melanocarpa</i>	Black Chokeberry	CG	6'-10' ht x 4'-10' w	4'	
COC	141	#5 Cont	<i>Cephalanthus occidentalis</i>	Common Buttonbush	CG	5'-12' ht x 4'-8' w	4'	
COR	69	#5 Cont	<i>Cornus racemosa</i>	Gray Dogwood	CG	10'-15' ht x 10'-15' w	6'	
COA	104	#5 Cont	<i>Corylus americana</i>	American Filbert	CG	8'-12' ht x 8'-12' w	6'	
COS	19	#3 Cont	<i>Cornus stolonifera</i>	Red Osier Dogwood	CG	3'-4' ht x 3'-4' w	4'	
DIL	327	#5 Cont	<i>Diervilla lonicera</i>	Dwarf Honeysuckle	CG	2'-3' ht x 2'-5' w	3'	
HAM	57	3' ht.	<i>Hamamelis vernalis</i>	Vernal Witchhazel	BB	6'-10' ht x 8'-15' w	6'	
HYA	768	3' ht.	<i>Hydrangea arborescens 'Annabelle'</i>	Annabelle Smooth Hydrangea	CG	3'-5' ht x 4'-6' w	3'	
HYP	50	2' ht.	<i>Hypericum frondosum 'Sunburst'</i>	Sunburst Golden St. Johnswort	CG	3'-4' ht x 3'-4' w	2'	
ILV	60	#5 Cont	<i>Ilex verticillata 'Red Sprite'</i>	Red Sprite Winterberry	CG	2.5'-3' ht x 2.5'-3' w	3'	Female
ILJ	8	2' ht.	<i>Ilex verticillata 'Jim Dandy'</i>	Jim Dandy Dwarf Winterberry	CG	2.5'-3' ht x 2.5'-3' w	3'	Male
LIB	57	#5 Cont	<i>Lindera benzoin</i>	Spicebush	CG	6'-12' ht x 6'-12' w	6'	
PHO	105	2.5' ht.	<i>Physocarpus opulifolius 'Summer Wine'</i>	Summer Wine Common Ninebark	CG	4'-6' ht x 4'-8' w	5'	Spring Dig Only
RHT	106	3' ht.	<i>Rhus typhina</i>	Staghorn Sumac	CG	10' ht x 10' w	8'	
RIA	255	#5 Cont	<i>Ribes americanum</i>	Wild Black Currant	CG	6'-12' ht x 6' w	4'	
SAC	74	3' ht.	<i>Sambucus canadensis</i>	American Elder	CG	10'-15' ht x 10'-15' w	8'	
SYC	194	#5 Cont	<i>Symphoricarpos chenaultii 'Hancock'</i>	Hancock Chenault Coralberry	CG	1.5'-2' ht x 6'-8' w	5'	
VID	25	3' ht.	<i>Viburnum dentatum 'Autumn Jazz'</i>	Autumn Jazz Arrowwood Viburnum	CG	6'-10' ht x 8'-12' w	5'	
VIL	95	#5 Cont	<i>Viburnum lentago</i>	Nannyberry	CG	14'-16' ht x 6'-12' w	6'	
VIP	55	#7 Cont	<i>Viburnum Prunifolium</i>	Blackhaw Viburnum	CG	12'-15' ht x 6'-12' w	6'	

PERENNIAL PLANTS, WETLAND TYPE, 2" DIAMETER BY 4" DEEP PLUG

Code	Botanical Name	Common Name	Units	# of Flats	Flat Size	Form	Spacing
SEDGE & MEADOW PLUGS AT 0 TO 3" BELOW NWL (2,573 SF WITH 800 PLUGS AT 24" O.C. SPACING RANDOMLY MIX IN DRIFT FORMS)*							
ASI	<i>Asclepias incarnata</i>	Swamp Milkweed	2	4	50	FLAT	24"
IRV	<i>Iris virginica shevei</i>	Blue Flag	2	4	50	FLAT	24"
LOC	<i>Lobelia cardinalis</i>	Cardinal Flower	2	4	50	FLAT	24"
VEH	<i>Verbena hastata</i>	American Blue Vervain	2	4	50	FLAT	24"

* PLUG PLANTING LAYOUT TO BE DONE IN A RANDOM PATTERN OF THE 4 SPECIES EACH IN A GROUPING OF 20 TO 25 PLANTS.

EMERGENT WETLAND PLUGS 3" TO 6" BELOW NWL (23,762 SF WITH 7,700 PLUGS AT 24" O.C. SPACING RANDOMLY MIX IN DRIFT FORMS)*

Code	Botanical Name	Common Name	Units	# of Flats	Flat Size	Form	Spacing
BOF	<i>Bolboschoenus fluviatilis</i>	River Bulrush	14	28	50	FLAT	24"
JUE	<i>Juncus effusus</i>	Common Rush	14	28	50	FLAT	24"
SCA	<i>Scirpus atrovirens</i>	Green Bulrush	13.5	27	50	FLAT	24"
SCT	<i>Schoenoplectus tabernaemontani</i>	Softstem Bulrush	14	28	50	FLAT	24"
SPE	<i>Sparganium eurycarpum</i>	Broadfruit Bur-reed	13.5	27	50	FLAT	24"

* PLUG PLANTING LAYOUT TO BE DONE IN A RANDOM PATTERN OF THE 5 SPECIES EACH IN A GROUPING OF 20 TO 25 PLANTS.

FILE NAME = 7-2754-ah1-1ndscap-det02.dgn



USER NAME = rjwang	DESIGNED - JC	REVISED -
PLOT SCALE = 2.0000' / in.	DRAWN - JC	REVISED -
PLOT DATE = 9/26/2017	CHECKED - RMG	REVISED -
	DATE - 9/5/2017	REVISED -

**STATE OF ILLINOIS
DEPARTMENT OF TRANSPORTATION**

LANDSCAPING DETAILS

SCALE: N/A SHEET 2 OF 2 SHEETS STA. TO STA.

F.A.U. RTE. 229B	SECTION 13-00215-30-PV	COUNTY KANE	TOTAL SHEETS 177	SHEET NO. 92
CONTRACT NO. 61D16				
ILLINOIS FED. AID PROJECT				

TRAFFIC SIGNAL LEGEND

(NOT TO SCALE)

ITEM	EXISTING	PROPOSED	ITEM	EXISTING	PROPOSED	ITEM	EXISTING	PROPOSED
CONTROLLER CABINET			HANDHOLE -SQUARE -ROUND	 	 	SIGNAL HEAD -(P) PROGRAMMABLE SIGNAL HEAD		
COMMUNICATION CABINET			HEAVY DUTY HANDHOLE -SQUARE -ROUND	 	 	SIGNAL HEAD WITH BACKPLATE -(P) PROGRAMMABLE SIGNAL HEAD -(RB) RETROREFLECTIVE BACKPLATE		
MASTER CONTROLLER			DOUBLE HANDHOLE			PEDESTRIAN SIGNAL HEAD AT RAILROAD INTERSECTIONS		
MASTER MASTER CONTROLLER			JUNCTION BOX			PEDESTRIAN SIGNAL HEAD WITH COUNTDOWN TIMER		
UNINTERRUPTABLE POWER SUPPLY			RAILROAD CANTILEVER MAST ARM			ILLUMINATED SIGN "NO LEFT TURN"/"NO RIGHT TURN"		
SERVICE INSTALLATION -(P) POLE MOUNTED			RAILROAD FLASHING SIGNAL			NUMBER OF CONDUCTORS, ELECTRIC CABLE NO. 14, UNLESS NOTED OTHERWISE. ALL DETECTOR LOOP CABLE TO BE SHIELDED		
SERVICE INSTALLATION -(G) GROUND MOUNTED -(GM) GROUND MOUNTED METERED	 	 	RAILROAD CROSSING GATE			GROUND CABLE IN CONDUIT, NO. 6 SOLID COPPER (GREEN)		
TELEPHONE CONNECTION			RAILROAD CROSSBUCK			ELECTRIC CABLE IN CONDUIT, TRACER NO. 14 1/C		
STEEL MAST ARM ASSEMBLY AND POLE			RAILROAD CONTROLLER CABINET			COAXIAL CABLE		
ALUMINUM MAST ARM ASSEMBLY AND POLE			UNDERGROUND CONDUIT (UC), GALVANIZED STEEL			VENDOR CABLE		
STEEL COMBINATION MAST ARM ASSEMBLY AND POLE WITH LUMINAIRE			TEMPORARY SPAN WIRE, TETHER WIRE, AND CABLE			COPPER INTERCONNECT CABLE, NO. 18, 3 PAIR TWISTED, SHIELDED		
SIGNAL POST -(BM) BARREL MOUNTED - TEMPORARY			SYSTEM ITEM	S	SP	FIBER OPTIC CABLE -NO. 62.5/125, MM12F -NO. 62.5/125, MM12F SM12F -NO. 62.5/125, MM12F SM24F		
WOOD POLE			INTERSECTION ITEM	I	IP	GROUND ROD -(C) CONTROLLER -(M) MAST ARM -(P) POST -(S) SERVICE		
GUY WIRE			REMOVE ITEM		R			
SIGNAL HEAD			RELOCATE ITEM		RL			
SIGNAL HEAD WITH BACKPLATE			ABANDON ITEM		A			
SIGNAL HEAD OPTICALLY PROGRAMMED			CONTROLLER CABINET AND FOUNDATION TO BE REMOVED		RCF			
FLASHER INSTALLATION -(FS) SOLAR POWERED	 	 	MAST ARM POLE AND FOUNDATION TO BE REMOVED		RMF			
PEDESTRIAN SIGNAL HEAD			SIGNAL POST AND FOUNDATION TO BE REMOVED		RPF			
PEDESTRIAN PUSH BUTTON -(APS) ACCESSIBLE PEDESTRIAN PUSH BUTTON	 	 	DETECTOR LOOP, TYPE I					
RADAR DETECTION SENSOR			PERFORMED DETECTOR LOOP					
VIDEO DETECTION CAMERA			SAMPLING (SYSTEM) DETECTOR					
RADAR/VIDEO DETECTION ZONE			INTERSECTION AND SAMPLING (SYSTEM) DETECTOR					
PAN, TILT, ZOOM (PTZ) CAMERA			QUEUE AND SAMPLING (SYSTEM) DETECTOR					
EMERGENCY VEHICLE LIGHT DETECTOR			WIRELESS DETECTOR SENSOR					
CONFIRMATION BEACON			WIRELESS ACCESS POINT					
WIRELESS INTERCONNECT								
WIRELESS INTERCONNECT RADIO REPEATER								

TS SHEET NO. 1

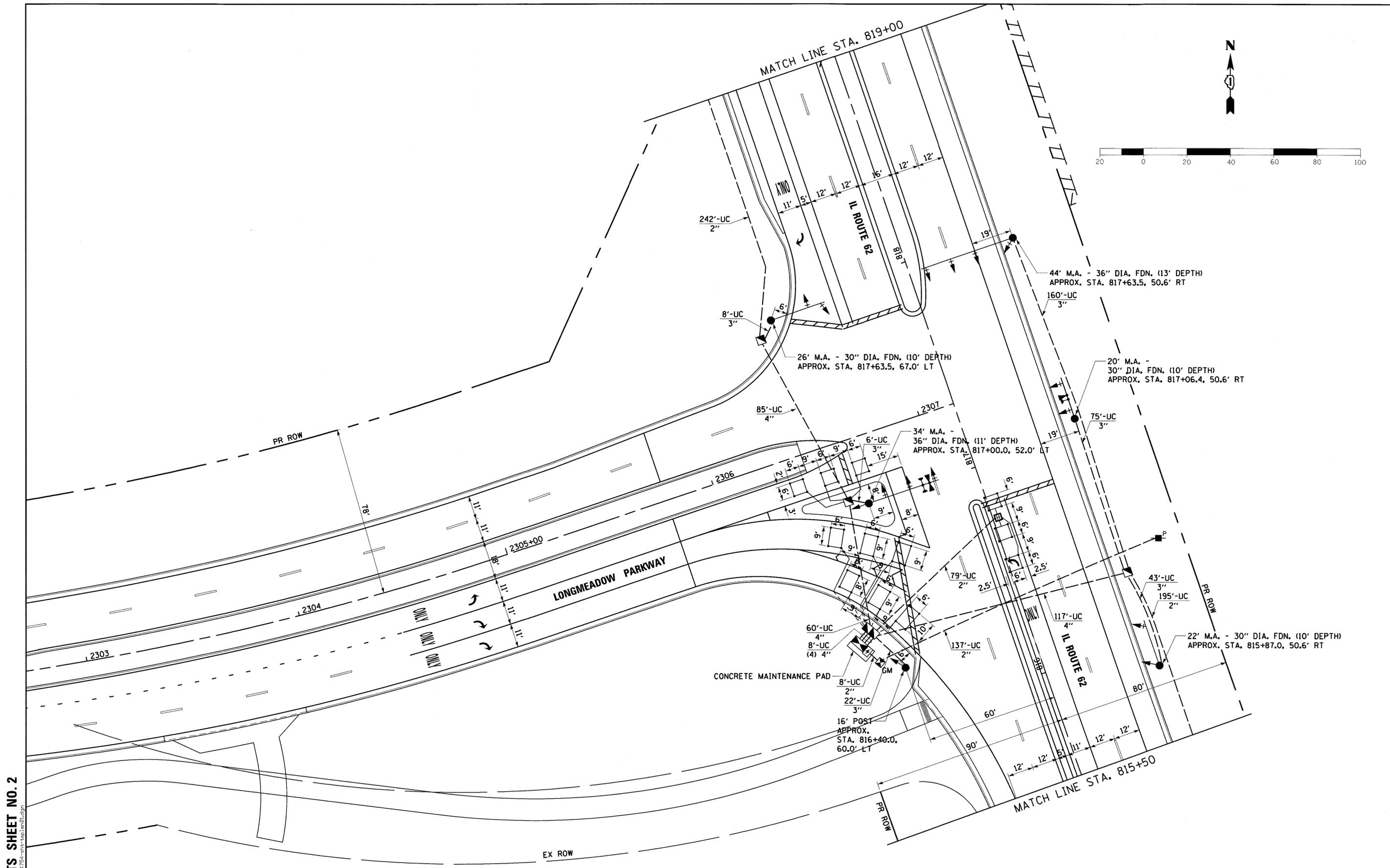

TS SHEET NO. 2



USER NAME = r.jiang	DESIGNED - MAP	REVISED -
DRAWN - RGJ	CHECKED - RMG	REVISED -
DATE - 9/5/2017		

STATE OF ILLINOIS
DEPARTMENT OF TRANSPORTATION

TRAFFIC SIGNAL INSTALLATION PLAN
ILLINOIS ROUTE 62 AT LONGMEADOW PARKWAY

SCALE: 1" = 20' SHEET 1 OF 2 SHEETS STA. TO STA.

F.A.U. RTE. 2298	SECTION 13-00215-30-PV	COUNTY KANE	TOTAL SHEETS 177	SHEET NO. 94
CONTRACT NO. 61D16				ILLINOIS FED. AID PROJECT

TS SHEET NO. 3

FILE NAME = 74754-sh1-top1-an2.dgn



USER NAME = r.jiang
 DRAWN = RGJ
 CHECKED = RMG
 DATE = 9/5/2017

DESIGNED - MAP
 DRAWN - RGJ
 CHECKED - RMG
 DATE = 9/5/2017

REVISED -
 REVISED -
 REVISED -
 REVISED -

STATE OF ILLINOIS
 DEPARTMENT OF TRANSPORTATION

TRAFFIC SIGNAL INSTALLATION PLAN
 ILLINOIS ROUTE 62 AT LONGMEADOW PARKWAY

SCALE: 1" = 20' SHEET 2 OF 2 SHEETS STA. TO STA.

F.A.U. RTE.	SECTION	COUNTY	TOTAL SHEETS	SHEET NO.
2298	13-00215-30-PV	KANE	177	95
CONTRACT NO. 61D16			ILLINOIS FED. AID PROJECT	

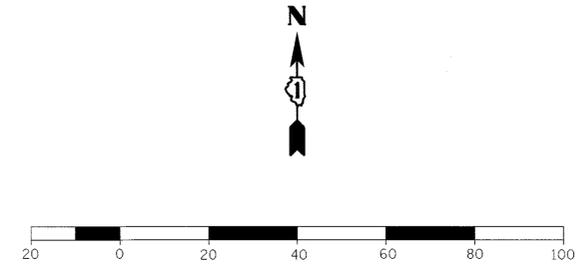
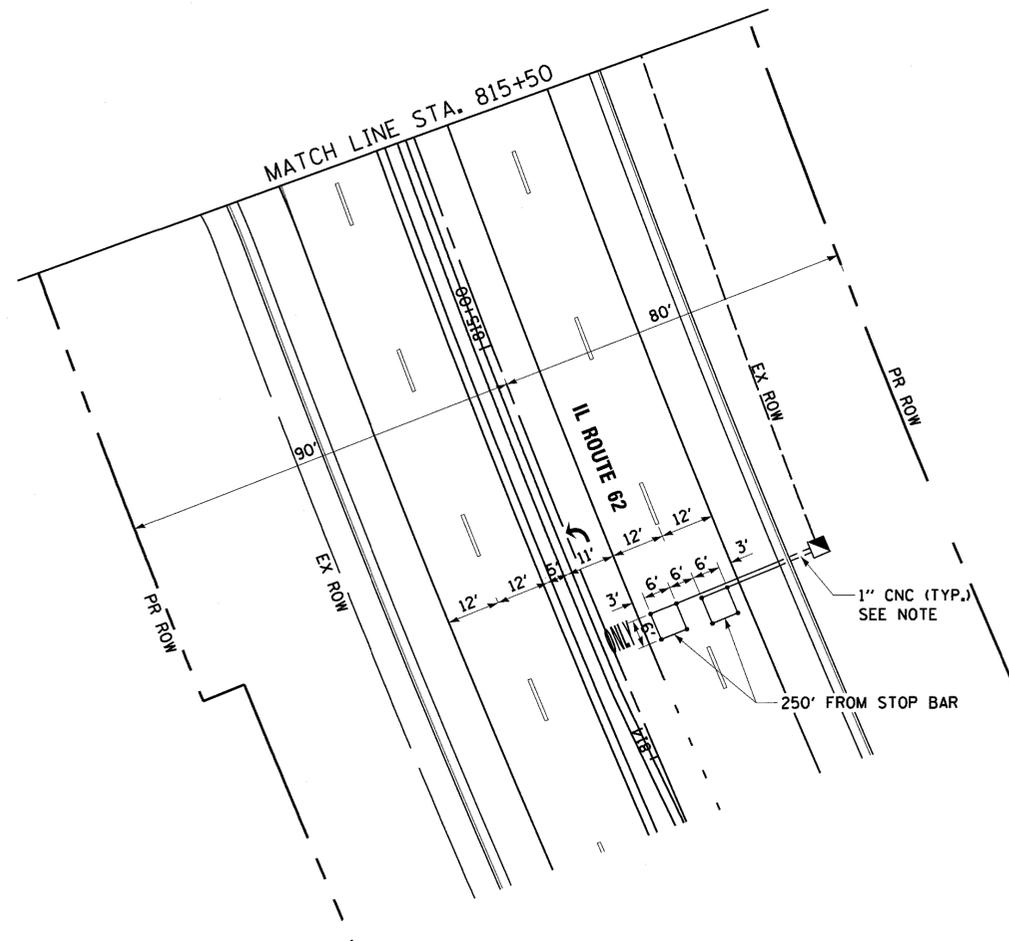
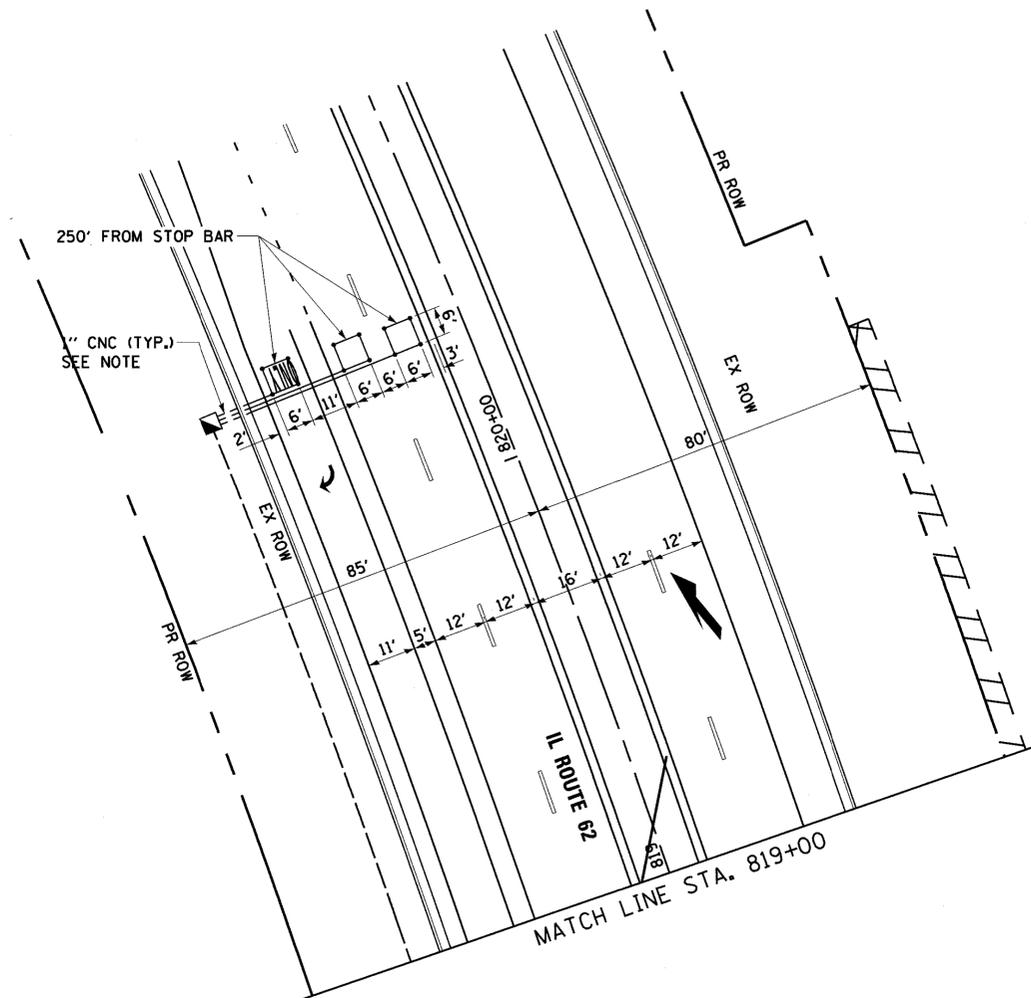

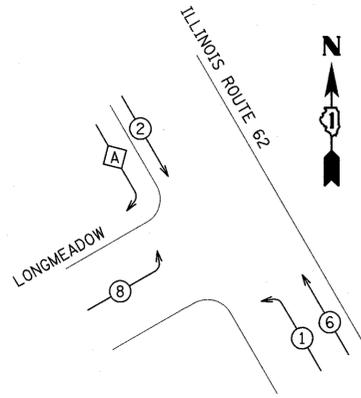

PHASE DESIGNATION DIAGRAM

OVERLAP LETTERS	=	PERMISSIVE PHASE	+	PROTECTED PHASE
A	=	2	+	8

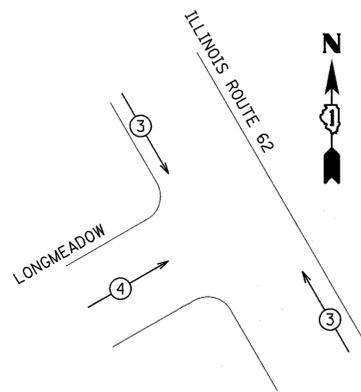

PROPOSED EMERGENCY VEHICLE PREEMPTION SEQUENCE

- LEGEND**
- ⊗ DUAL ENTRY PHASE
 - * SINGLE ENTRY PHASE
 - ⊕ OVERLAP
 - ⊖ PEDESTRIAN PHASE
 - * NUMBER REFERS TO ASSOCIATED PHASE

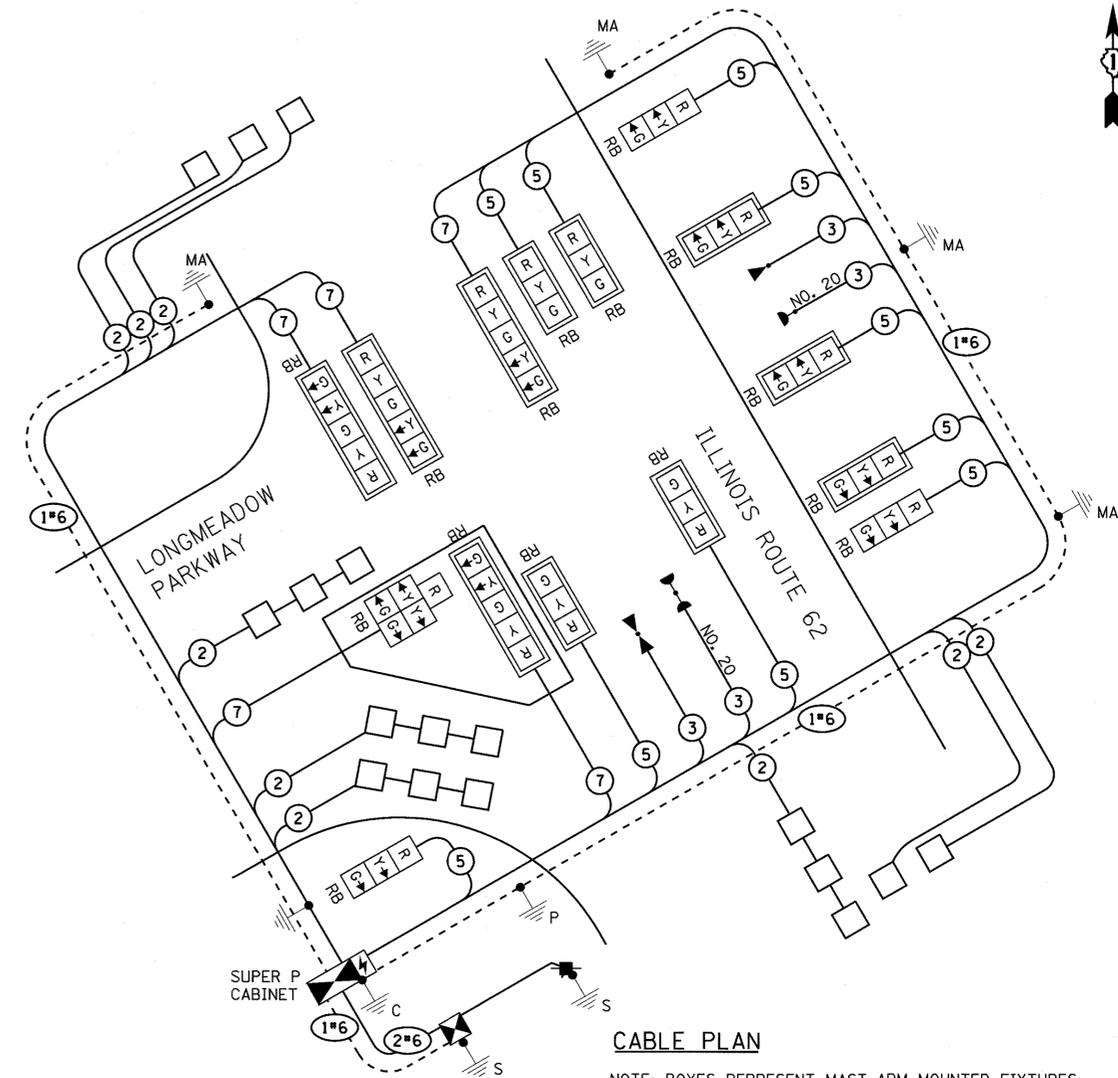

CABLE PLAN

NOTE: BOXES REPRESENT MAST-ARM MOUNTED FIXTURES. ALL FIXTURES (BOTH MAST ARM MOUNTED AND POST MOUNTED) SHALL BE FITTED WITH RETROREFLECTIVE BACKPLATES ("RB").

ELECTRICAL LOAD CHART

IDOT TRAFFIC SIGNAL INSTALLATION ELECTRICAL SERVICE REQUIREMENTS				TOTAL WATTAGE
TYPE	NO. LAMPS	WATTAGE (LED)	% OPERATION	
SIGNAL (RED)	15	11	0.50	82.5
SIGNAL (YELLOW)	14	20	0.05	14.0
SIGNAL (GREEN)	14	12	0.45	75.6
ARROW	12	10	0.10	12.0
CONTROLLER	1	100	1.00	100.0
UPS	1	25	1.00	25.0
TOTAL				309.1

ENERGY COSTS TO
KANE COUNTY DIVISION OF TRANSPORTATION
 41W011 BURLINGTON ROAD
 ST CHARLES, IL 60175

ENERGY SUPPLY CONTACT : KATHY KOPCZICK
 PHONE : (630) 985-4074
 COMPANY : COM. EDISON

TS SHEET NO. 4



USER NAME = r.jiang	DESIGNED - MAP	REVISED -
DRAWN - RGJ	REVISOR -	
CHECKED - RMG	REVISOR -	
DATE - 9/5/2017	REVISOR -	

STATE OF ILLINOIS
 DEPARTMENT OF TRANSPORTATION

CABLE PLAN, PHASE DESIGNATION DIAGRAM,
 AND EMERGENCY VEHICLE PREEMPTION SEQUENCE
 ILLINOIS ROUTE 62 AT LONGMEADOW PARKWAY

F.A.U. RTE. 2298	SECTION 13-00215-30-PV	COUNTY KANE	TOTAL SHEETS 177	SHEET NO. 96
CONTRACT NO. 61D16				
ILLINOIS FED. AID PROJECT				

SCALE: N/A SHEET OF SHEETS STA. TO STA.

SIGN PANELS - TYPE 1 OR TYPE 2



DESIGN SERIES	AREA (SQ FT)	SIGN PANEL TYPE	SHEETING TYPE	QTY. REQUIRED
D	15.0	2	ZZ	1

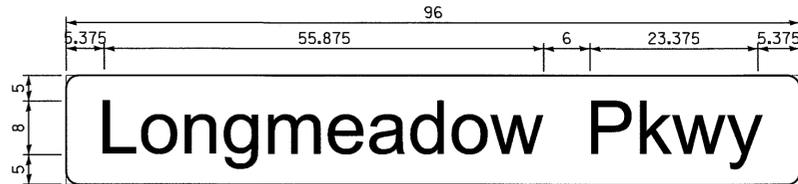

DESIGN SERIES	AREA (SQ FT)	SIGN PANEL TYPE	SHEETING TYPE	QTY. REQUIRED
C	12.0	2	ZZ	2

SCHEDULE OF QUANTITIES

DESCRIPTION	UNIT OF MEASURE	TOTAL QUANTITY
SIGN PANEL - TYPE 2	SQ FT	39
SERVICE INSTALLATION, GROUND MOUNTED, METERED	EACH	1
UNDERGROUND CONDUIT, GALVANIZED STEEL, 2" DIA.	FOOT	661
UNDERGROUND CONDUIT, GALVANIZED STEEL, 3" DIA.	FOOT	314
UNDERGROUND CONDUIT, GALVANIZED STEEL, 4" DIA.	FOOT	278
HANDHOLE	EACH	5
HEAVY-DUTY HANDHOLE	EACH	1
DOUBLE HANDHOLE	EACH	1
FULL-ACTUATED CONTROLLER AND TYPE SUPER P CABINET	EACH	1
ELECTRIC CABLE IN CONDUIT, SIGNAL NO. 14 3C	FOOT	433
ELECTRIC CABLE IN CONDUIT, SIGNAL NO. 14 5C	FOOT	2650
ELECTRIC CABLE IN CONDUIT, SIGNAL NO. 14 7C	FOOT	1095
ELECTRIC CABLE IN CONDUIT, LEAD-IN, NO. 14 1 PAIR	FOOT	2773
ELECTRIC CABLE IN CONDUIT, SERVICE, NO. 6 2C	FOOT	145
ELECTRIC CABLE IN CONDUIT, EQUIPMENT GROUNDING CONDUCTOR, NO. 6, 1C	FOOT	1169
TRAFFIC SIGNAL POST, GALVANIZED STEEL 16 FT.	EACH	1
STEEL MAST ARM ASSEMBLY AND POLE, 20 FT.	EACH	1
STEEL MAST ARM ASSEMBLY AND POLE, 22 FT.	EACH	1
STEEL MAST ARM ASSEMBLY AND POLE, 26 FT.	EACH	1
STEEL MAST ARM ASSEMBLY AND POLE, 34 FT.	EACH	1
STEEL MAST ARM ASSEMBLY AND POLE, 44 FT.	EACH	1
CONCRETE FOUNDATION, TYPE A	FOOT	8
CONCRETE FOUNDATION, TYPE C	FOOT	4
CONCRETE FOUNDATION, TYPE E 30-INCH DIAMETER	FOOT	30
CONCRETE FOUNDATION, TYPE E 36-INCH DIAMETER	FOOT	24
SIGNAL HEAD, LED, 1-FACE, 3 SECTION, MAST-ARM MOUNTED	EACH	7
SIGNAL HEAD, LED, 1-FACE, 3 SECTION, BRACKET MOUNTED	EACH	3
SIGNAL HEAD, LED, 1-FACE, 5-SECTION, BRACKET MOUNTED	EACH	1
SIGNAL HEAD, LED, 1-FACE, 5-SECTION, MAST-ARM MOUNTED	EACH	4
TRAFFIC SIGNAL BACKPLATE, RETROREFLECTIVE	EACH	15
INDUCTIVE LOOP DETECTOR	EACH	17
PREFORMED DETECTOR LOOP	FOOT	444
LIGHT DETECTOR	EACH	3
LIGHT DETECTOR AMPLIFIER	EACH	1
EMERGENCY VEHICLE PRIORITY SYSTEM LINE SENSOR CABLE, NO. 20 3/C	FOOT	435
UNINTERRUPTABLE POWER SUPPLY, SPECIAL	EACH	1

TS SHEET NO. 5

FILE NAME = 74754-sh1-tasoc.dgn



USER NAME = rjjang	DESIGNED - MAP	REVISED -
PLOT SCALE = 100.0001' / in.	DRAWN - RGJ	REVISED -
PLOT DATE = 9/1/2017	CHECKED - RMG	REVISED -
	DATE - 9/5/2017	REVISED -

STATE OF ILLINOIS
DEPARTMENT OF TRANSPORTATION

MAST ARM MOUNTED STREET NAME SIGNS
AND SCHEDULE OF QUANTITIES
ILLINOIS ROUTE 62 AT LONGMEADOW PARKWAY

SCALE: N/A SHEET OF SHEETS STA. TO STA.

F.A.J. RTE. 2298	SECTION 13-00215-30-PV	COUNTY KANE	TOTAL SHEETS 177	SHEET NO. 97
				CONTRACT NO. 61D16
ILLINOIS FED. AID PROJECT				

SIGN PANEL – TYPE 1 OR TYPE 2

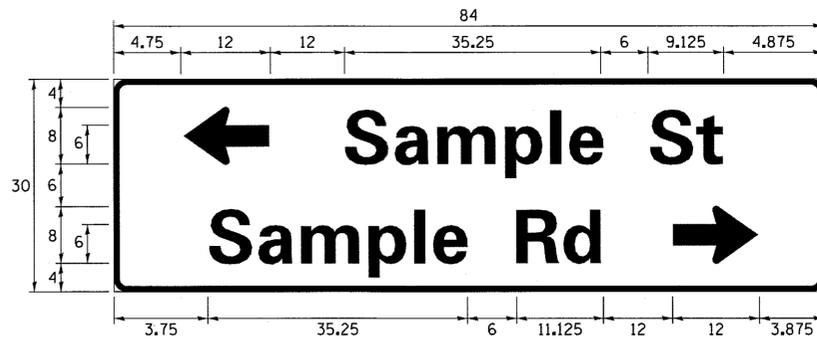
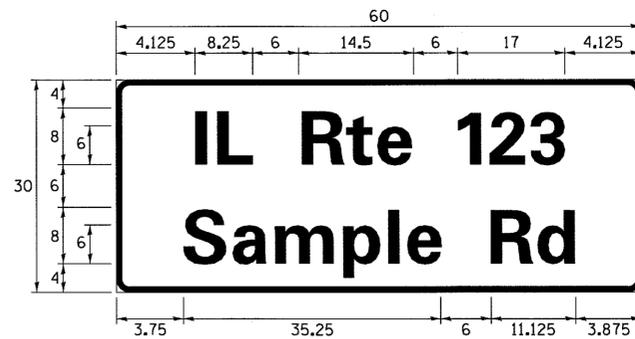
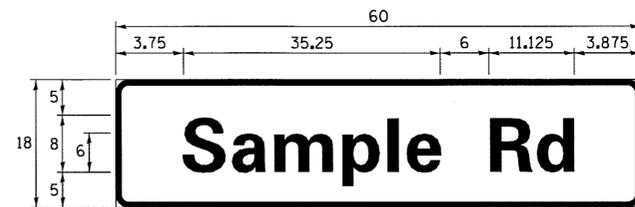

DESIGN SERIES	AREA (SQ FT)	SIGN PANEL TYPE	SHEETING TYPE	QTY. REQUIRED
D OR C	-	1 OR 2	ZZ	-

ALL DIMENSIONS ARE IN INCHES EXCEPT NOTED OTHERWISE

COMMON STREET NAME ABBREVIATIONS AND WIDTHS

NAME	ABBREVIATION	WIDTH (INCH)	
		SERIES "C"	SERIES "D"
AVENUE	Ave	15.000	18.250
BOULEVARD	Blvd	17.125	20.000
CIRCLE	Cir	11.125	13.000
COURT	Ct	8.250	9.625
DRIVE	Dr	8.625	10.125
HIGHWAY	Hwy	18.375	22.000
ILLINOIS	IL	7.000	8.250
LANE	Ln	9.125	10.750
PARKWAY	Pkwy	23.375	27.375
PLACE	Pl	7.125	7.750
ROAD	Rd	9.625	11.125
ROUTE	Rte	12.625	14.500
STREET	St	8.000	9.125
TERRACE	Ter	12.625	14.625
TRAIL	Tr	7.750	9.125
UNITED STATES	US	10.375	12.250

GENERAL NOTES

- WHERE MAST ARM MOUNTED STREET NAME SIGNS ARE SPECIFIED, THE MAST ARM ASSEMBLY AND POLES SHALL BE DESIGNED TO SUPPORT THE LOADINGS CALLED FOR ON STANDARDS 877001, 877002, 877006, 877011 AND 877012, AS APPLICABLE, PLUS TWO (2) SIGN PANELS 2'-6" x 8'-0" MOUNTED AS SHOWN. THE DESIGN SHALL BE IN ACCORDANCE WITH THE REQUIREMENTS OF THE CURRENT "STANDARD SPECIFICATIONS FOR STRUCTURAL SUPPORTS FOR HIGHWAY SIGNS, LUMINAIRES, AND TRAFFIC SIGNALS" AS PUBLISHED BY THE AMERICAN ASSOCIATION OF STATE HIGHWAY AND TRANSPORTATION OFFICIALS FOR 80 M.P.H. WIND VELOCITY.
- ALL SIGNS SHALL CONSIST OF A WHITE LEGEND AND BORDER (TYPE ZZ SHEETING) ON A GREEN BACKGROUND (TYPE ZZ SHEETING)
- THE SIGN LENGTH SHALL BE IN 6-INCH INCREMENTS, BUT THE OVERALL LENGTH SHALL NOT EXCEED 8'-0". ALL BORDERS SHALL BE 3/4" WIDE. CORNER RADIUS SHALL BE 1-7/8". THE SPACING BETWEEN THE WORDS SHOULD BE 6", IF POSSIBLE, BUT MAY BE REDUCED TO 5" WHEN SPACING IS CRITICAL. A MINIMUM OF 2-1/2" SHALL BE INCLUDED BETWEEN THE WORD AND THE RIGHT AND LEFT EDGES OF THE SIGN.
- A PREFERRED METHOD FOR THE SIGN DESIGN IS TO USE SERIES "D" LETTER ON A ONE-LINE SIGN 18" IN HEIGHT AND A MAXIMUM OF 8'-0" IN WIDTH. IF SERIES "D" DOES NOT FIT ON A 8'-0" SIGN, THEN SERIES "C" SHOULD BE TRIED. IF SERIES "C" DOES NOT FIT ON A 8'-0" SIGN, A 30" HIGH TWO-LINE SIGN CAN BE USED. THE CROSSROAD DESIGNATION AS TO STREET, AVENUE, ETC. SHOULD BE SPELLED OUT ON THE SECOND LINE, IF THE ABBREVIATION CANNOT FIT ON THE FIRST LINE.
- LED ILLUMINATED STREET NAME SIGNS CAN BE USED IN PLACE OF REGULAR SIGN PANELS BUT ANY SPECIAL WORDING AND SYMBOLOGY MUST BE APPROVED BY THE DEPARTMENT. GENERAL DESIGN REQUIREMENT AS LISTED ABOVE (COLOR, FONT, SIZE, ETC.) MUST BE FOLLOWED.
- SIGNFIX ALUMINUM CHANNEL FRAMING SYSTEM SHALL BE USED FOR ALL SIGNS ATTACHED TO SIGNAL POLES AND POSTS.

LOCAL SUPPLIERS:

- J.O. HERBERT COMPANY, INC
MIDLOTHIAN, VA
- WESTERN REMAC, INC.
WOODRIDGE, IL

PARTS LISTING:

- SIGN CHANNEL PART #HPN053 (MED. CHANNEL)
- SIGN SCREWS 1/4" x 14 x 1" H.W.H. #3
- BRACKETS SELF TAPPING WITH NEOPRENE WASHER
- CHANNEL CLAMPS WITH STAINLESS STEEL STRAPPING PART #HPN034 (UNIVERSAL)

OTHER BRANDS OF MOUNTING HARDWARE ARE ACCEPTABLE, BASED UPON THE DEPARTMENT'S APPROVAL AND COMPATIBILITY WITH THE CHANNEL/BACKET OF THE ABOVE PRODUCT.

MOUNTING LOCATION

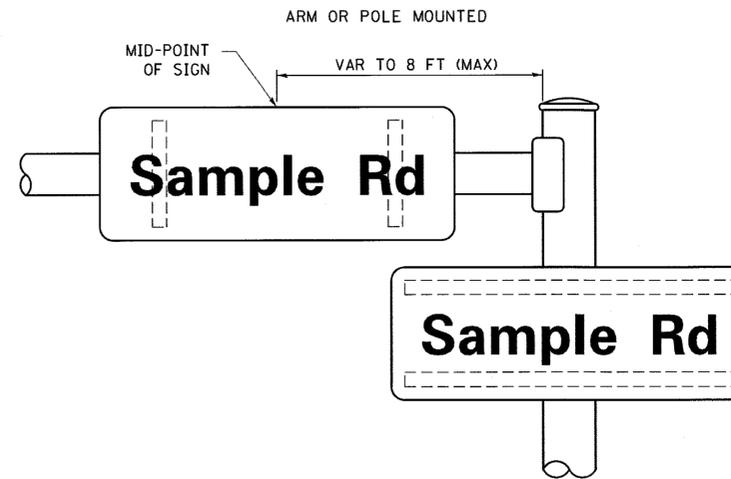

SUPPORTING CHANNELS

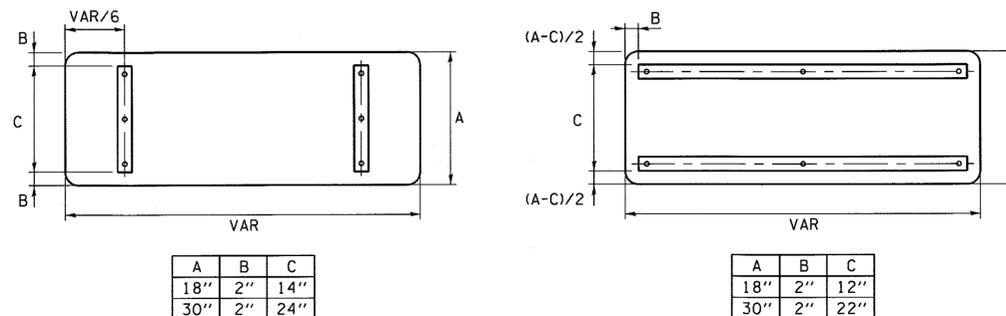

STANDARD ALPHABETS SPACING CHART

(8") UPPER CASE AND (6") LOWER CASE

FHWA SERIES "C"				FHWA SERIES "D"			
CHARACTER	LEFT SPACING (INCH)	WIDTH (INCH)	RIGHT SPACING (INCH)	CHARACTER	LEFT SPACING (INCH)	WIDTH (INCH)	RIGHT SPACING (INCH)
A	0.240	5.122	0.240	A	0.240	6.804	0.240
B	0.880	4.482	0.480	B	0.960	5.446	0.400
C	0.720	4.482	0.720	C	0.800	5.446	0.800
D	0.880	4.482	0.720	D	0.960	5.446	0.800
E	0.880	4.082	0.480	E	0.960	4.962	0.400
F	0.880	4.082	0.240	F	0.960	4.962	0.240
G	0.720	4.482	0.720	G	0.800	5.446	0.800
H	0.880	4.482	0.880	H	0.960	5.446	0.960
I	0.880	1.120	0.880	I	0.960	1.280	0.960
J	0.240	4.082	0.880	J	0.240	5.122	0.960
K	0.880	4.482	0.480	K	0.960	5.604	0.400
L	0.880	4.082	0.240	L	0.960	4.962	0.240
M	0.880	5.284	0.880	M	0.960	6.244	0.960
N	0.880	4.482	0.880	N	0.960	5.446	0.960
O	0.720	4.722	0.720	O	0.800	5.684	0.800
P	0.880	4.482	0.720	P	0.960	5.446	0.240
Q	0.720	4.722	0.720	Q	0.800	5.684	0.800
R	0.880	4.482	0.480	R	0.960	5.446	0.400
S	0.480	4.482	0.480	S	0.400	5.446	0.400
T	0.240	4.082	0.240	T	0.240	4.962	0.240
U	0.880	4.482	0.880	U	0.960	5.446	0.960
V	0.240	4.962	0.240	V	0.240	6.084	0.240
W	0.240	6.084	0.240	W	0.240	7.124	0.240
X	0.240	4.722	0.240	X	0.400	5.446	0.400
Y	0.240	5.122	0.240	Y	0.240	6.884	0.240
Z	0.480	4.482	0.480	Z	0.400	5.446	0.400
a	0.320	3.842	0.640	a	0.400	4.562	0.720
b	0.720	4.082	0.480	b	0.800	4.802	0.480
c	0.480	4.002	0.240	c	0.480	4.722	0.240
d	0.480	4.082	0.720	d	0.480	4.802	0.800
e	0.480	4.082	0.320	e	0.480	4.722	0.320
f	0.320	2.480	0.160	f	0.320	2.882	0.160
g	0.480	4.082	0.720	g	0.480	4.802	0.800
h	0.720	4.082	0.640	h	0.800	4.722	0.720
i	0.720	1.120	0.720	i	0.800	1.280	0.800
j	0.000	2.320	0.720	j	0.000	2.642	0.800
k	0.720	4.322	0.160	k	0.800	5.122	0.160
l	0.720	1.120	0.720	l	0.800	1.280	0.800
m	0.720	6.724	0.640	m	0.800	7.926	0.720
n	0.720	4.082	0.640	n	0.800	4.722	0.720
o	0.480	4.082	0.480	o	0.480	4.882	0.480
p	0.720	4.082	0.480	p	0.800	4.802	0.480
q	0.480	4.082	0.720	q	0.480	4.802	0.800
r	0.720	2.642	0.160	r	0.800	3.042	0.160
s	0.320	3.362	0.240	s	0.320	3.762	0.240
t	0.080	2.882	0.080	t	0.080	3.202	0.080
u	0.640	4.082	0.720	u	0.720	4.722	0.800
v	0.160	4.722	0.160	v	0.160	5.684	0.160
w	0.160	7.524	0.160	w	0.160	9.046	0.160
x	0.000	5.202	0.000	x	0.000	6.244	0.000
y	0.160	4.962	0.160	y	0.160	6.004	0.160
z	0.240	3.362	0.240	z	0.240	4.002	0.240
1	0.720	1.680	0.880	1	0.800	2.000	0.960
2	0.480	4.482	0.480	2	0.800	5.446	0.800
3	0.480	4.482	0.480	3	1.440	5.446	0.800
4	0.240	4.962	0.720	4	0.160	6.004	0.960
5	0.480	4.482	0.480	5	0.800	5.446	0.800
6	0.720	4.482	0.720	6	0.800	5.446	0.800
7	0.240	4.482	0.720	7	0.560	5.446	0.560
8	0.480	4.482	0.480	8	0.800	5.446	0.800
9	0.480	4.482	0.480	9	0.800	5.446	0.800
0	0.720	4.722	0.720	0	0.800	5.684	0.800
-	0.240	2.802	0.240	-	0.240	2.802	0.240

TS SHEET NO. 6

FILE NAME =	USER NAME = drivkasgn	DESIGNED - LP/IP	REVISED - LP 07/01/2015	STATE OF ILLINOIS DEPARTMENT OF TRANSPORTATION	DISTRICT ONE MAST ARM MOUNTED STREET NAME SIGNS	F.A.U. RTE.	SECTION	COUNTY	TOTAL SHEETS	SHEET NO.	
p:\IL\084EBIDINTEG\Illinois.gov\PIDOT\Documents\IDOT_Offices\District_1\Projects\Dist1\DRAWN\CADData\CAD\Sheets\ts02.dgn	PLOT SCALE = 50.0000' / in.	CHECKED - IP	REVISED -			2298	13-00215-30-PV	KANE	177	98	
Default	PLOT DATE = 7/31/2015	DATE - 10/01/2014	REVISED -			SCALE:	SHEET OF SHEETS	STA. TO STA.	CONTRACT NO. 61D16		
						ILLINOIS FED. AID PROJECT					

LOOP DETECTOR NOTES

1. EACH PAIR OF LOOP WIRES SHALL BE PLACED IN A SEPARATE EMPTY COILABLE NONMETALLIC CONDUIT FROM THE EDGE OF PAVEMENT TO THE HANDHOLE. SPACING BETWEEN THE HOLES DRILLED IN THE PAVEMENT SHALL NOT BE LESS THAN 6" (150 mm). EMPTY COILABLE NONMETALLIC CONDUIT SHALL BE INCLUDED IN THE COST OF THE LOOP WIRE.
2. THE NUMBER OF LOOP TURNS SHALL BE AS RECOMMENDED BY THE AMPLIFIER MANUFACTURER. ALL ADJACENT SIDES OF THE LOOPS SHALL BE INSTALLED IN SUCH A WAY THAT THE CURRENT FLOW IS IN THE SAME DIRECTION TO REINFORCE ITS MAGNETIC FIELDS FOR SMALL VEHICLE DETECTION.
3. EACH LOOP LEAD-IN SHALL BE IDENTIFIED AND PERMANENTLY TAGGED IN THE HANDHOLE. EACH LEAD-IN CABLE TAG SHALL INDICATE THE LOCATION OF THE LOOP, LOOP ROTATION (CLOCKWISE/COUNTERCLOCKWISE), LOOP LEAD-IN DIRECTION (IN OR OUT), LOOP CABLE NUMBER AND LOCATION IN CABINET, AND NUMBER OF TURNS IN THE DETECTOR LOOPS IN WATER PROOF INK AS INDICATED ON THE DISTRICT 1 STANDARD TRAFFIC SIGNAL DESIGN DETAIL. THE CONTRACTOR SHALL MARK LOOP LOCATIONS ON RECORD DRAWINGS AND PRESENT TO THE ENGINEER AFTER FINAL INSPECTION. LOOPS SHALL BE MARKED BY LANE AND LOOP NUMBER. SEE DETAIL BELOW.
4. ALL LOOP CABLE SHALL BE FASTENED WITH PLASTIC TIE WRAP TO THE HANDHOLE HOOKS.
5. IN ASPHALT PAVEMENT, LOOPS SHOULD BE PLACED IN THE BINDER AND DIVEHOLES MARKED AT THE CURB WITH A SAW-CUT. THE SAW-CUT SHALL BE CUT IN ACCORDANCE WITH LOCAL AND E.P.A. DUST CONTROL REQUIREMENTS. DETECTOR LOOP(S) SHALL NOT BE INSTALLED IN WET CONDITIONS AND THE SAW-CUTS MUST BE FREE OF DEBRIS AND RESIDUE SUCH AS DUST AND WATER WHICH IS TO BE ACHIEVED BY THE USE OF COMPRESSED AIR, WIRE BRUSHING AND HEAT DRYING ACCORDING TO SEALANT MANUFACTURER REQUIREMENTS. THE DETECTOR WIRE SHALL BE HELD IN PLACE BY THE USE OF FORM WEDGES. WEDGES SHALL BE SPACED NO MORE THAN 18" (450 mm) APART.
6. LOOP SPLICES SHALL BE SOLDERED USING A SOLDERING IRON. BLOW TORCHES OR OTHER DEVICES WHICH OXIDIZE COPPER CABLE SHALL NOT BE ALLOWED FOR SOLDERING OPERATIONS. SEE DETAIL BELOW RIGHT.
7. PREFORMED DETECTOR LOOPS SHALL BE USED, AS SHOWN ON THE PLANS, WHERE NEW CONCRETE PAVEMENT IS PROPOSED. THE INSTALLATION OF PREFORMED LOOPS SHALL BE IN ACCORDANCE WITH THE DISTRICT 1 SPECIFICATIONS OR AS DIRECTED BY THE ENGINEER.

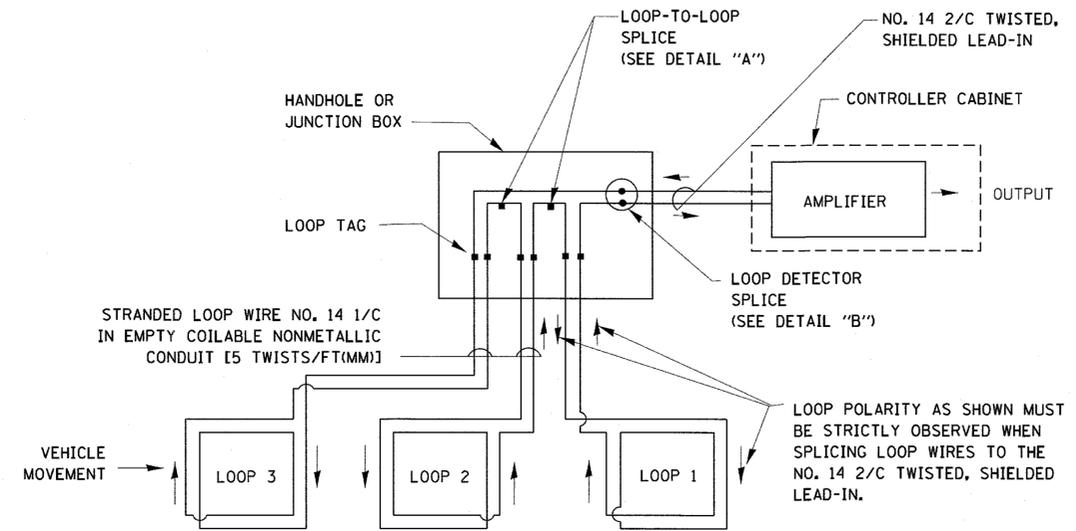

DETECTOR LOOP WIRING SCHEMATIC

- LOOPS SHALL BE SPLICED IN SERIES.
- SAW-CUTS SHALL BE A MINIMUM WIDTH OF 5/16" (8 mm).
- SAW-CUT DEPTHS SHALL BE 3" (75 mm). IF IN CONCRETE, THE SAW-CUT DEPTH SHALL BE TO THE TOP OF THE REINFORCEMENT.
- LOOP CORNERS SHALL BE DRILLED WITH A 2" (50 mm) DIAMETER CORE.

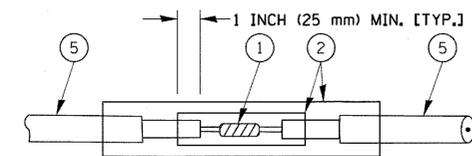

DETAIL "A"
LOOP-TO-LOOP SPLICE

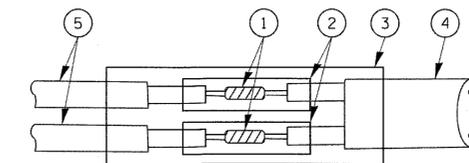

DETAIL "B"
LOOP-TO-CONTROLLER SPLICE

TYPE I LOOP

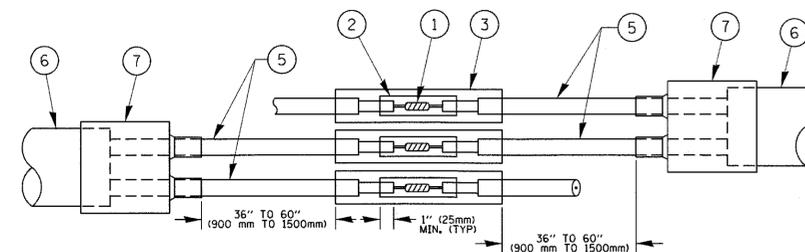

DETAIL "A"
LOOP-TO-LOOP SPLICE

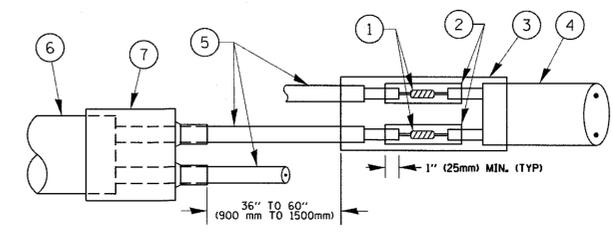

DETAIL "B"
LOOP-TO-CONTROLLER SPLICE

PRE-FORMED LOOP

LOOP DETECTOR SPLICE

- ① WESTERN UNION SPLICE SOLDERED WITH ROSIN CORE FLUX. ALL EXPOSED SURFACES OF THE SOLDER SHALL BE SMOOTH. THE WESTERN UNION SPLICES SHALL BE STAGGERED.
- ② WCSMW 30/100 HEAT SHRINK TUBE, MINIMUM LENGTH 3" (75 mm), UNDERWATER GRADE.
- ③ WCS 200/750 HEAT SHRINK TUBE, MINIMUM LENGTH 6" (150 mm), UNDERWATER GRADE.
- ④ NO. 14 2/C TWISTED, SHIELDED CABLE.
- ⑤ LOOP CONDUCTOR WITH FLEXIBLE PLASTIC TUBE.
- ⑥ PRE-FORMED LOOP
- ⑦ XL POLYOLEFIN 2 CONDUCTOR BREAKOUT SEALS, TYCO CBR-2 OR APPROVED EQUAL

LOOP LEAD-IN CABLE TAG

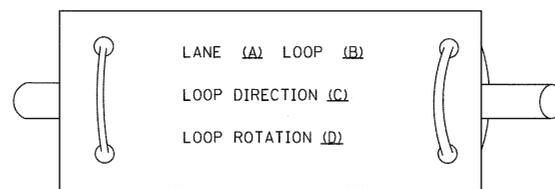

- A. LANE 1 IS THE LANE CLOSEST TO THE CENTERLINE OF THE ROADWAY
- B. LOOP #1 IS THE LOOP IN THE LANE CLOSEST TO THE INTERSECTION.
- C. LABEL LOOP CABLE "IN" OR LOOP CABLE "OUT".
- D. LABEL LOOP CABLE CLOCKWISE OR LOOP CABLE COUNTERCLOCKWISE.

TS SHEET NO. 7

FILE NAME =	USER NAME = foatemj	DESIGNED - DAD	REVISED - DAG 1-1-14	STATE OF ILLINOIS DEPARTMENT OF TRANSPORTATION	DISTRICT ONE STANDARD TRAFFIC SIGNAL DESIGN DETAILS			F.A.U. RTE. 2298	SECTION 13-00215-30-PV	COUNTY KANE	TOTAL SHEETS 177	SHEET NO. 99	
c:\pw_work\pwt\dot\foatemj\d0108315\ts05.dgn	PLOT SCALE = 50.0000' / 1"	DRAWN - BCK	REVISI -		SCALE: NONE	SHEET NO. 2 OF 7 SHEETS	STA.	TO STA.	TS-05		CONTRACT NO. 61D16		
	PLOT DATE = 1/13/2014	CHECKED - DAD	REVISI -		FED. ROAD DIST. NO. 1 ILLINOIS FED. AID PROJECT								
		DATE - 10-28-09	REVISI -										

