

STATE OF ILLINOIS  
DEPARTMENT OF TRANSPORTATION

ROUTE NO.	SECTION	COUNTY	TOTAL SHEETS	SHEET NO.
S.B.I. F.A. 646	(102) BR-3	Whiteside	57	14
ILLINOIS FED. AID PROJECT-				

SHEET NO. 2  
24 SHEETS

CONTRACT NO. 64426

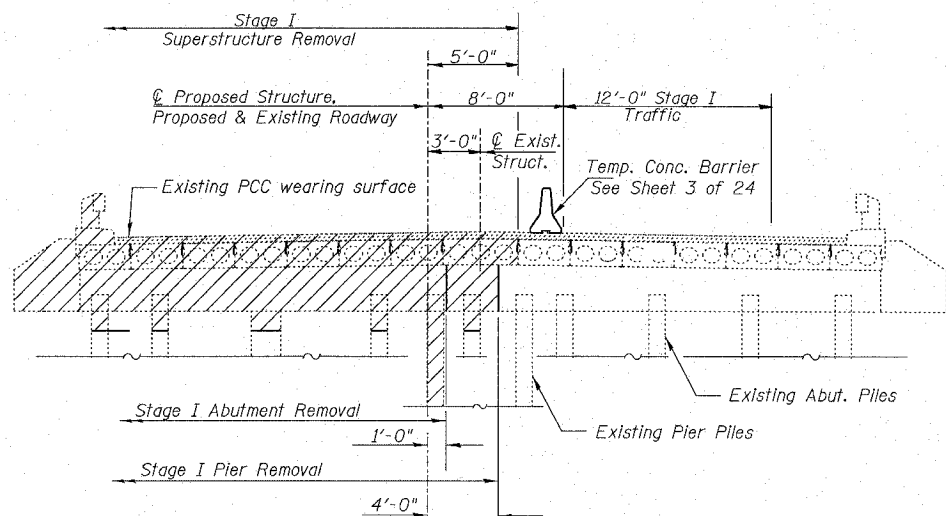

**STAGE I REMOVAL**

Stage Construction Notes:

1. All sections are looking south.
2. For quantity of of Temporary Concrete Barrier see Roadway Plans.

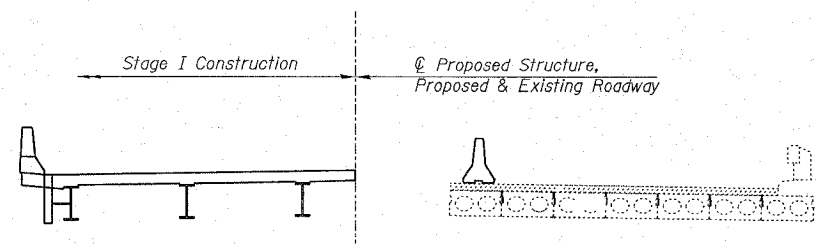

**STAGE I CONSTRUCTION**

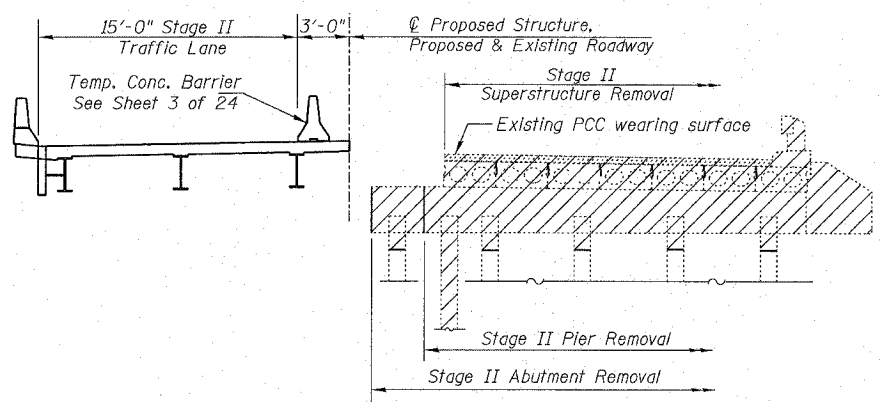

**STAGE II REMOVAL**

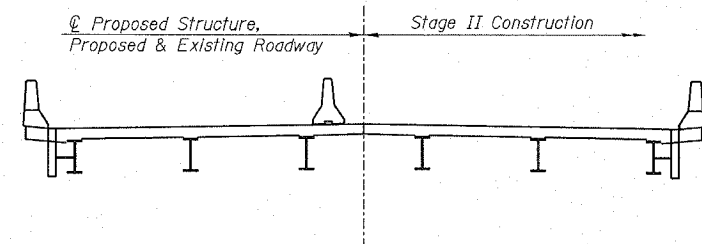

**STAGE II CONSTRUCTION**

**INDEX OF DRAWINGS**

Sht. No.	Sht. Title
1	General Plan and Elevation
2	Stage Construction
3	Temporary Concrete Barrier
4 & 5	Deck Elevations
6	Deck Plan and Section
7	Superstructure Details
8	Neoprene Expansion Joints
9	Structural Steel Framing Plan
10	Diaphragm & Splice Details
11	Bearing Details
12	Anchor Bolt Details for Bearings
13	North Abutment
14	North Abutment Details
15	South Abutment
16	South Abutment Details
17	Pier #1
18	Pier #2
19	Pile Details
20	Bar Splicer Details
21	Cantilever Forming Brackets
22, 23 & 24	Soil Boring Log

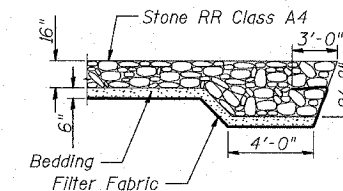

**SECTION A-A**  
Typical Flank Stone Riprap Treatment

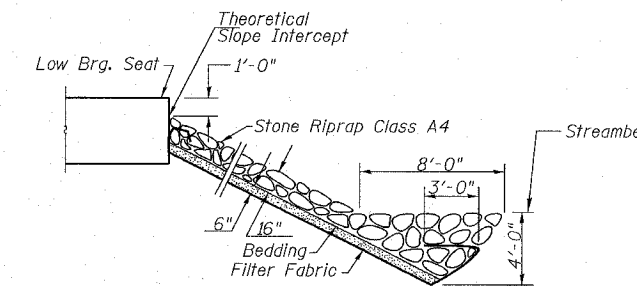

**SECTION B-B**  
Typical Toe Stone Riprap Treatment

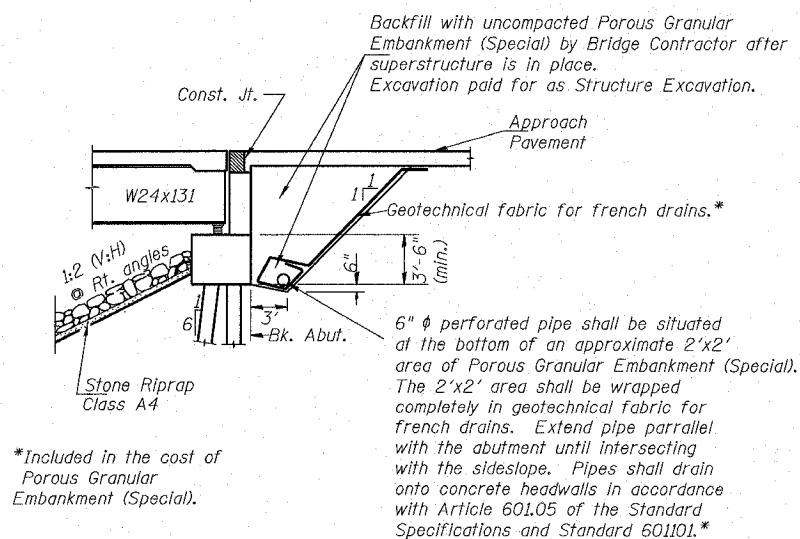

**SECTION THRU ABUTMENT**

at right angle to abut.

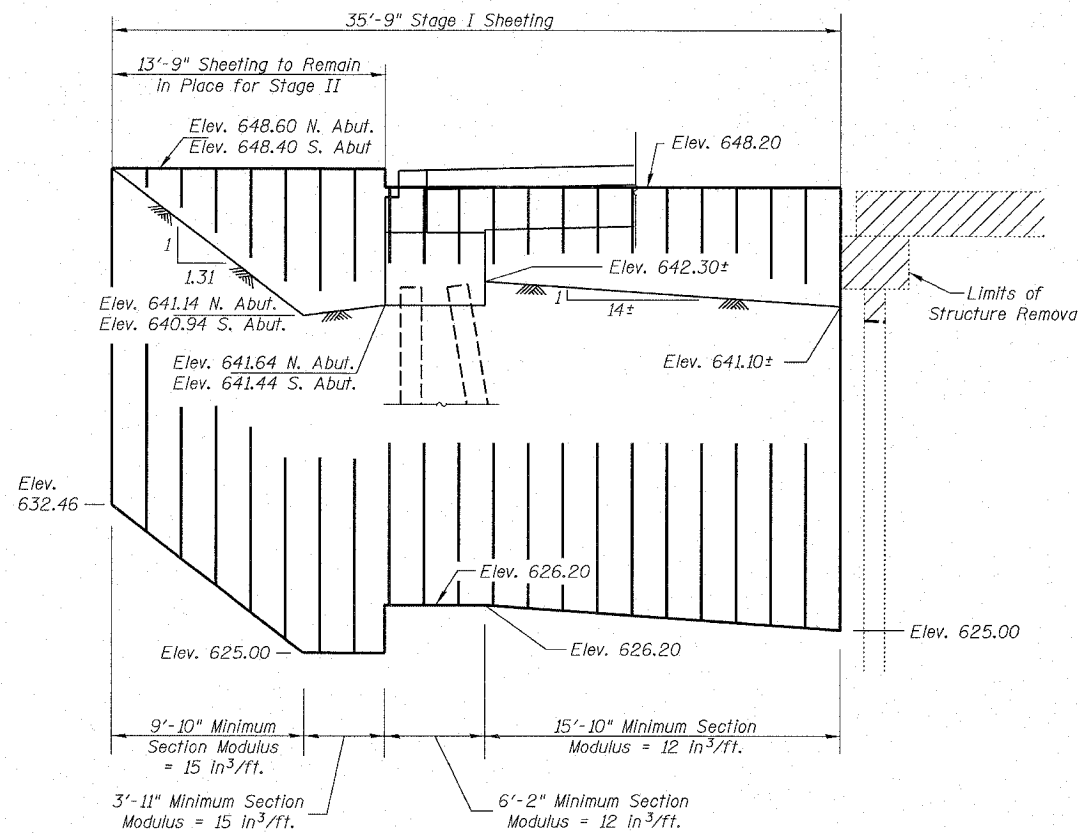

**TEMPORARY SHEET PILING**

Slopes and distances are along sheeting (parallel to  $\phi$  Roadway)  
North Abutment shown. South Abutment the same.

**STAGE CONSTRUCTION**  
IL RTE 40 OVER WINNEBAGO DITCH  
F.A.P. 646 SECTION (102)BR-3  
WHITESIDE COUNTY  
STATION 558+38  
S.N.098-0109

DESIGNED	DDB	<p>RANDOLPH &amp; ASSOCIATES, INC. 111 N. FISHAW PARKWAY, PEORIA, IL 61614-2124 TEL: 309-249-8800 FAX: 309-249-8805 TOLL FREE: 1-800-361-9222 WWW.RANDOLPH-ASSOCIATES.COM CONSULTING ENGINEERS &amp; LAND SURVEYORS</p>	FILE NUMBER	136.110
CHECKED	AMPH		DATE	Aug. 2005
DRAWN	JDB			
CHECKED	DDB			

R:\Projects\0136\0136-110\Win ph 11\br stage plan\set\02 Stage Construct ion.dgn  
 10:38:47 AM  
 9/19/2005