

F.A. RTE.	SECTION	COUNTY	TOTAL SHEETS	SHEET NO.
573	116R-4	DEKALB	416	259
STA.		TO STA.		
FED. ROAD DIST. NO.		ILLINOIS	FED. AID PROJECT	

CURB AND GUTTER OUTLET, SPECIAL

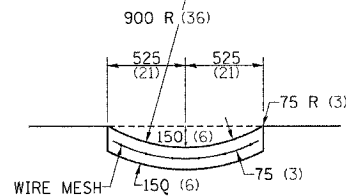
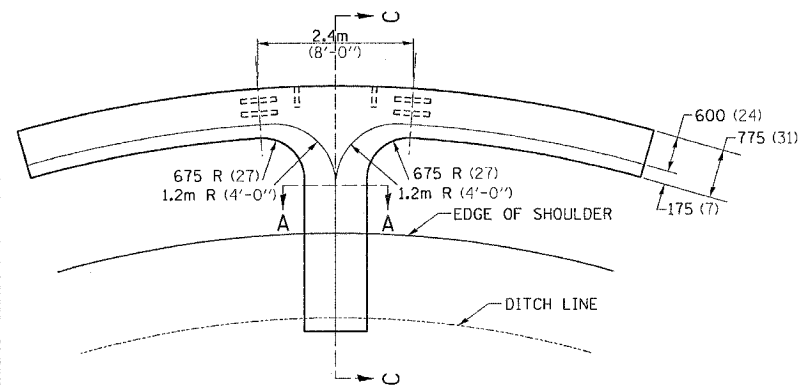

QUANTITY OF CONCRETE
SECTION A-A = 4.72m³/m (0.07 CU.YD./FT.)
8' SECTION OF CURB & GUTTER UP TO
SECTION A-A = 0.57 m³ (0.75 CU.YD.)

SECTION A-A

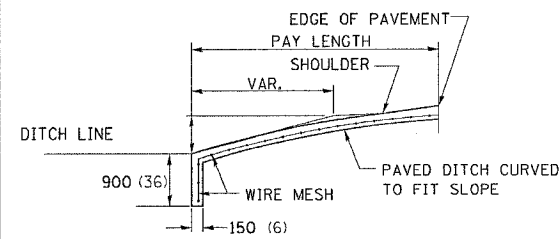

SECTION C-C

NOTE:

CLASS SI CONCRETE SHALL BE USED THROUGHOUT. CURB AND GUTTER OUTLET SHALL BE TIED TO PAVEMENT SLAB WITH 2 TIE BARS, 750(30) LONG - 750(30) CENTERS. OUTLET SHALL BE TIED TO CURB AND GUTTER AT CONTRACTION JOINTS AS SHOWN. GUTTER OUTLET AND PAVED DITCH SHALL BE REINFORCED WITH WIRE MESH HAVING A WEIGHT OF AT LEAST 2.83 Kg/m² (58 LBS/FT.²) COST TO BE INCLUDED IN THE UNIT PRICE PER (CUBIC METER) (CU.YD.) FOR CLASS SI CONCRETE (OUTLET).

ALL DIMENSIONS ARE IN MILLIMETERS (INCHES) UNLESS OTHERWISE NOTED.

CURB AND GUTTER OUTLET, SPECIAL 18.4

REVISED 9-5-95

DETAIL OF BITUMINOUS SHOULDER AT GUARD RAIL

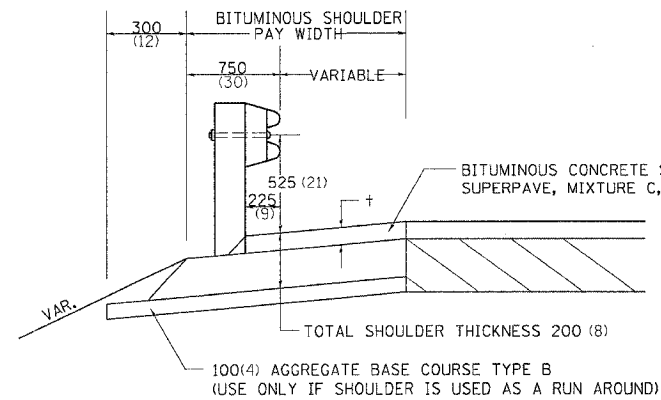

+ = SEE TYPICAL SECTIONS FOR THICKNESS

GENERAL NOTES

THE TOP LIFT SHALL NOT BE PLACED BEHIND THE GUARDRAIL POSTS. WHEN PLACING THE TOP LIFT THE RAIL MUST BE REMOVED FROM THE POSTS. THE POST SHALL NOT BE REMOVED.

THE HEIGHT OF THE GUARD RAIL SHALL BE 525 (21) FROM THE FINISHED SURFACE.

THE BITUMINOUS SHOULDER SHALL BE CONSTRUCTED IN ACCORDANCE WITH SECTION 482 EXCEPT THE TOP LIFT SHALL BE BITUMINOUS CONCRETE SURFACE COURSE, SUPERPAVE, MIXTURE C, N50. THE WORK WILL BE PAID FOR AT THE CONTRACT UNIT PRICE PER TON FOR BITUMINOUS CONCRETE SURFACE COURSE, SUPERPAVE, MIXTURE C, N50, AND SQUARE METER (SQUARE YARD) FOR BITUMINOUS SHOULDERS SUPERPAVE OF THE THICKNESS SPECIFIED. THE REMOVAL & REINSTALLATION OF THE GUARDRAIL WILL BE INCLUDED IN THE COST OF THE BITUMINOUS CONCRETE SURFACE COURSE, SUPERPAVE, MIXTURE C, N50.

ALL DIMENSIONS ARE IN MILLIMETERS (INCHES) UNLESS OTHERWISE NOTED.

DETAIL OF BITUMINOUS SHOULDER AT GUARD RAIL 23.4

REVISED 1-17-02

BITUMINOUS SHOULDER

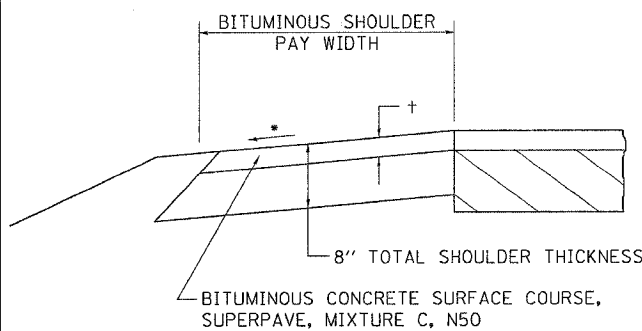

+ = SEE TYPICAL SECTIONS FOR THICKNESS

ALL DIMENSIONS ARE IN MILLIMETERS (INCHES) UNLESS OTHERWISE NOTED.

GENERAL NOTES

THE BITUMINOUS SHOULDER SHALL BE CONSTRUCTED IN ACCORDANCE WITH SECTION 482 EXCEPT THE TOP LIFT SHALL BE BITUMINOUS CONCRETE SURFACE COURSE, SUPERPAVE, MIXTURE C, N50. THE WORK WILL BE PAID FOR AT THE CONTRACT UNIT PRICE PER TON FOR BITUMINOUS CONCRETE SURFACE COURSE, SUPERPAVE, MIXTURE C, N50, AND SQUARE YARD FOR BITUMINOUS SHOULDERS SUPERPAVE OF THE THICKNESS SPECIFIED.

USE BITUMINOUS CONCRETE SURFACE COURSE, SUPERPAVE, MIXTURE C, N50, WHEN RESURFACING EXISTING BITUMINOUS SHOULDERS. THE THICKNESS IS SHOWN ON THE TYPICAL SECTIONS. THIS WORK WILL BE PAID FOR AT THE CONTRACT UNIT PRICE PER TON FOR BITUMINOUS CONCRETE SURFACE COURSE, SUPERPAVE, MIXTURE C, N50.

REMOVAL OF MATERIAL FOR PLACEMENT OF THE BITUMINOUS SHOULDER TO BE PAID FOR IN UNITS FOR EXCAVATING AND GRADING EXISTING SHOULDERS OR IN CUBIC YARDS FOR EARTH EXCAVATION OR EARTH EXCAVATION WIDENING.

* 4% WHEN MAINLINE IS ON TANGENT. FOR CROSS SLOPE ON SUPERELEVATION SECTION, SEE HIGHWAY STANDARD 482001 OR 482006.

BITUMINOUS SHOULDER 23.4a

REVISED 5-30-03

SIDEWALK AND DRIVEWAY PAVEMENT PAY AREAS

- PAY FOR AS**
- SIDEWALK REMOVAL
 - DRIVEWAY PAVEMENT REMOVAL
 - PCC SIDEWALK 127 (5)
 - PCC DRIVEWAY PAVEMENT 178 (7)

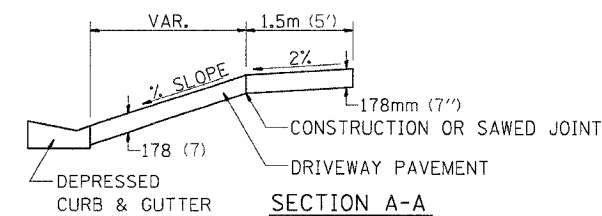
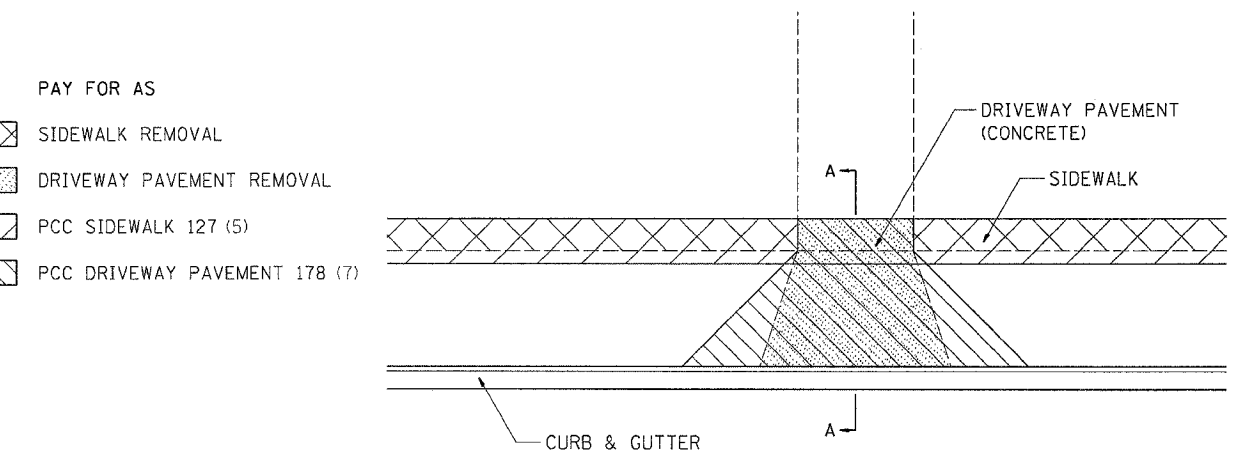

FOR DETAILS ON DIMENSIONS AND GRADES, SEE DISTRICT STANDARD 25.1 OR PLANS.

ALL DIMENSIONS ARE IN MILLIMETERS (INCHES) UNLESS OTHERWISE NOTED.

SIDEWALK AND DRIVEWAY PAVEMENT PAY AREAS 35.4

REVISED 10-15-04

PLOT DATE = Fri, Sep 02 07:12:28 2005
 FILE NAME = C:\projects\c201700\job1700\pl.dgn
 REFERENCE = REF5