

Contract #64A50

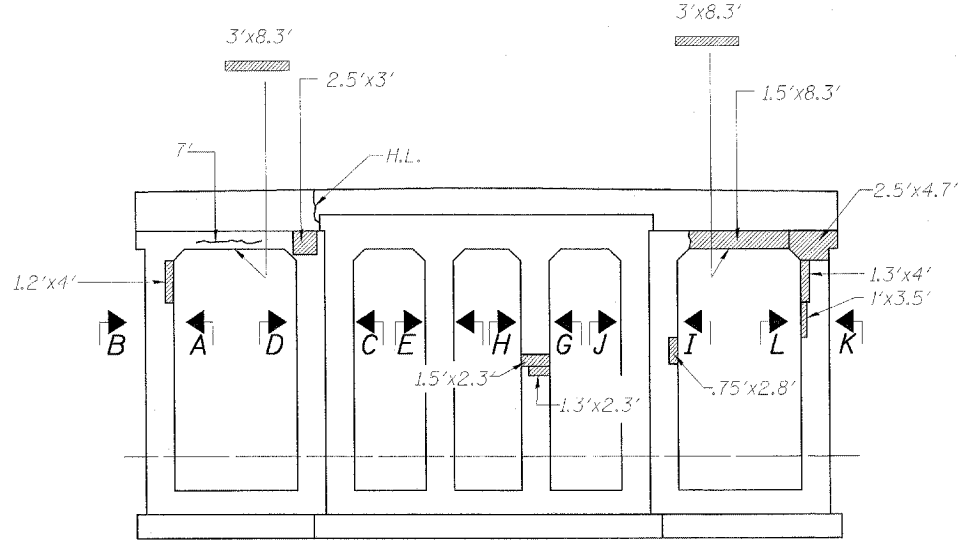

PIER 1-NORTH FACE

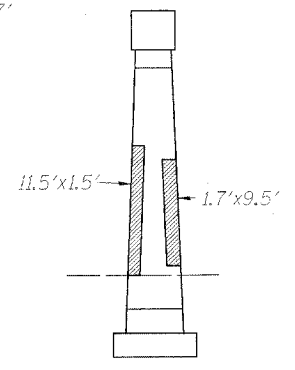

SECTION A

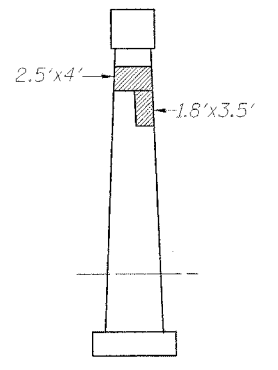

SECTION B

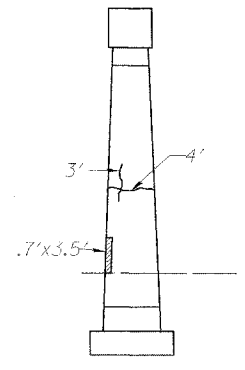

SECTION C

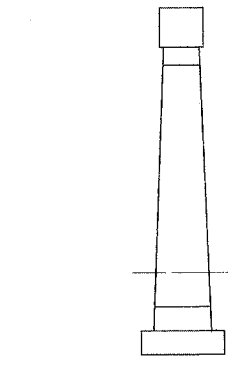

SECTION D

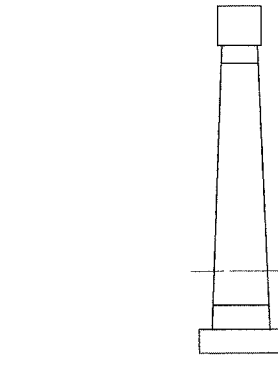

SECTION E

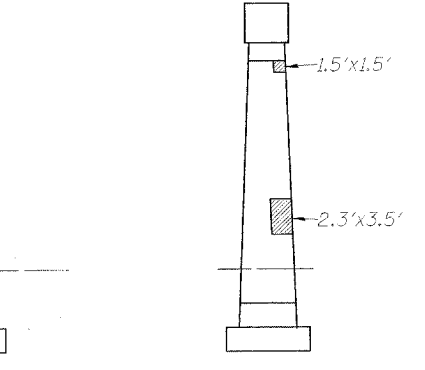

SECTION F

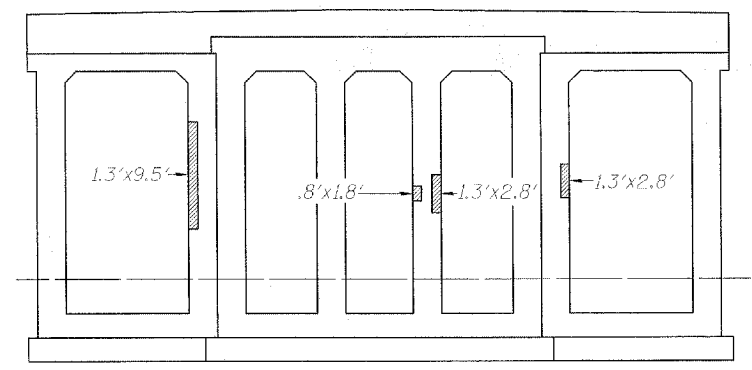

PIER 1-SOUTH FACE

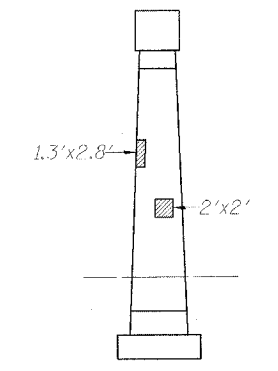

SECTION G

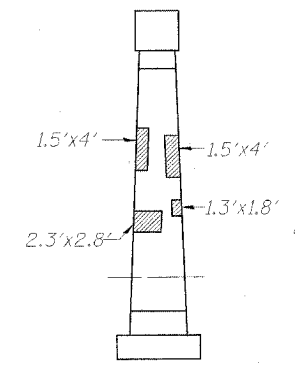

SECTION H

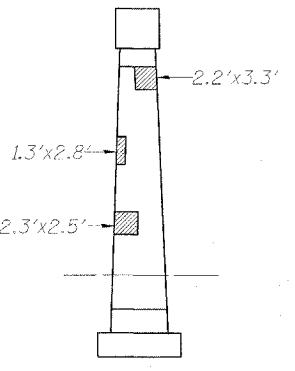

SECTION I

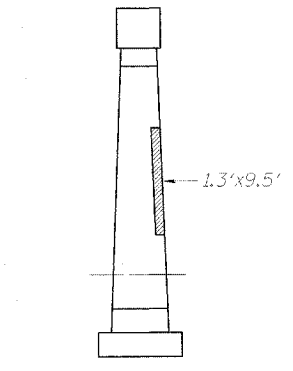

SECTION J

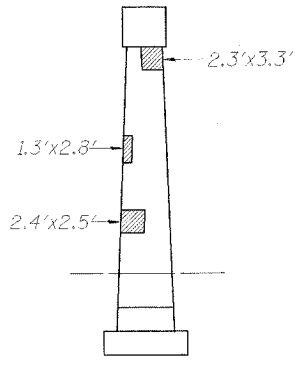

SECTION K

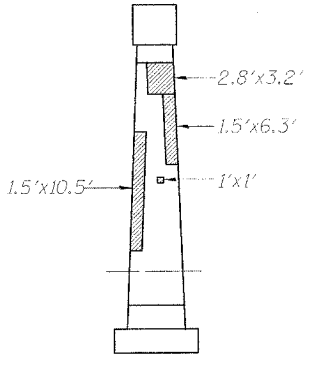

SECTION L

LEGEND

- Formed Concrete Repair
Depth equal to or less than 5"
- Epoxy Crack Sealing
- Hairline Crack - Not to be sealed

Note: Crack widths are $\frac{1}{8}'' \pm \frac{1}{16}''$ unless otherwise noted.

BILL OF MATERIAL - PIER 1

ITEM	UNIT	QUANTITY
Epoxy Crack Sealing	Foot	14.0
Formed Concrete Repair (Depth equal to or less than 5")	Sq Ft	303

PIER 1 REPAIRS

F.A.P. ROUTE 324 (IL 23)
SECTION 26 VBR-1
DEKALB COUNTY
STATION 1773+30.24
STRUCTURE NO. 019-0005

Clark Dietz

CHAMPAIGN, ILLINOIS
CHICAGO, ILLINOIS
EVANSVILLE, INDIANA
INDIANAPOLIS, INDIANA
KENOSHA, WISCONSIN
SPRING GREEN, WISCONSIN

REVISIONS		DRAWING NUMBER
NAME	DATE	
		S-10