

STATE OF ILLINOIS
DEPARTMENT OF TRANSPORTATION

ROUTE NO.	SECTION	COUNTY	SHEETS	SHEET NO.
IL 100	117B-4	SCOTT	39	26
FED. ROAD DIST. NO. 6	ILLINOIS	FED. AID PROJECT - ROUTE 552		

SHEET NO. 6
6 SHEETS

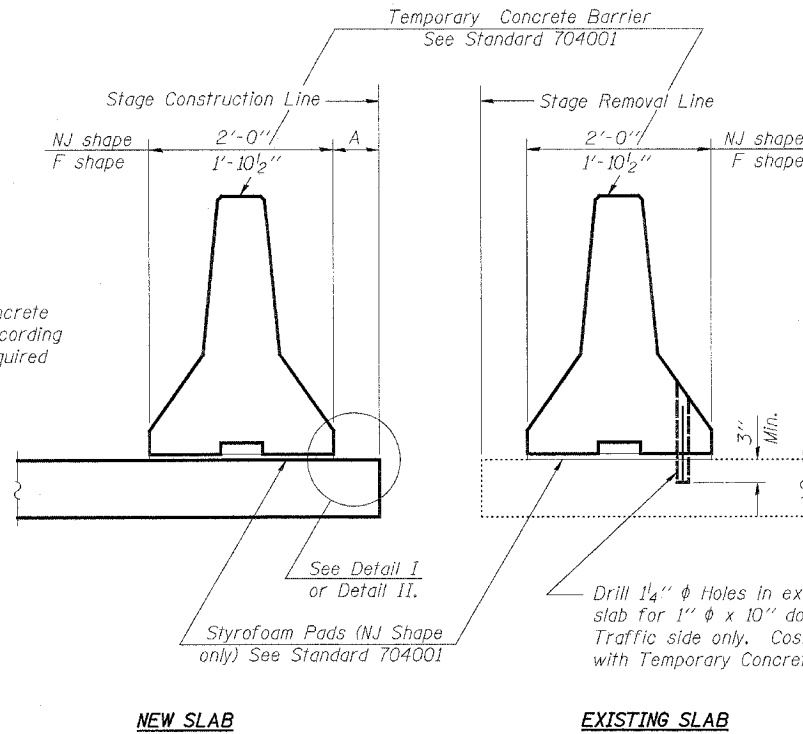

When "A" is 3'-6" or less, the temporary concrete barrier shall be anchored to the new slab according to Detail I or Detail II. No anchorage is required when "A" is greater than 3'-6".

NOTES

- Detail I - With Bar Splicer or Couplers:**
Connect one (1) 1"x7"x10" steel \bar{P} to the top layer of couplers with 2- $\frac{5}{8}$ " ϕ bolts screwed to coupler at approximate \bar{C} of each barrier panel.
- Detail II - With Extended Reinforcement Bars:**
Connect one (1) 1"x7"x10" steel \bar{P} to the concrete slab with 2- $\frac{5}{8}$ " ϕ Expansion Anchors or cast in place inserts spaced between the top layer of reinforcement at approximate \bar{C} of each barrier panel.
- Cost of anchorage is included with Temporary Concrete Barrier.

SECTIONS THRU SLAB

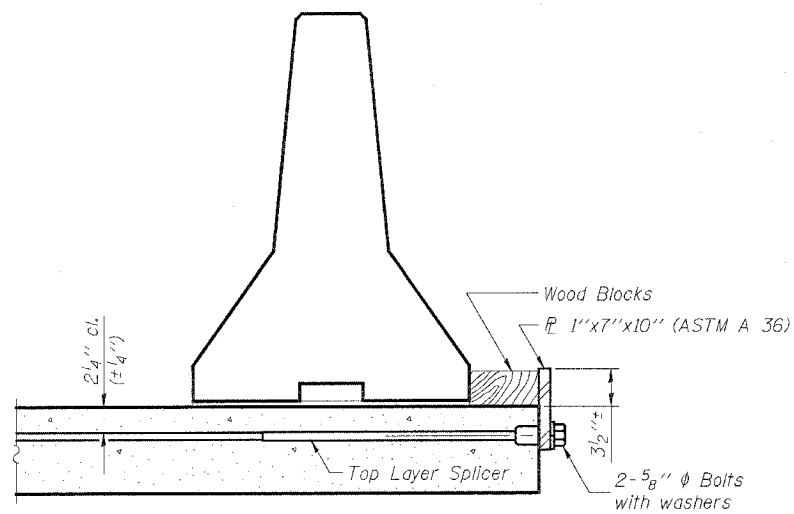

DETAIL I

The 1"x7"x10" Plate shall not be removed until Stage II Construction forms and reinforcement bars are in place.

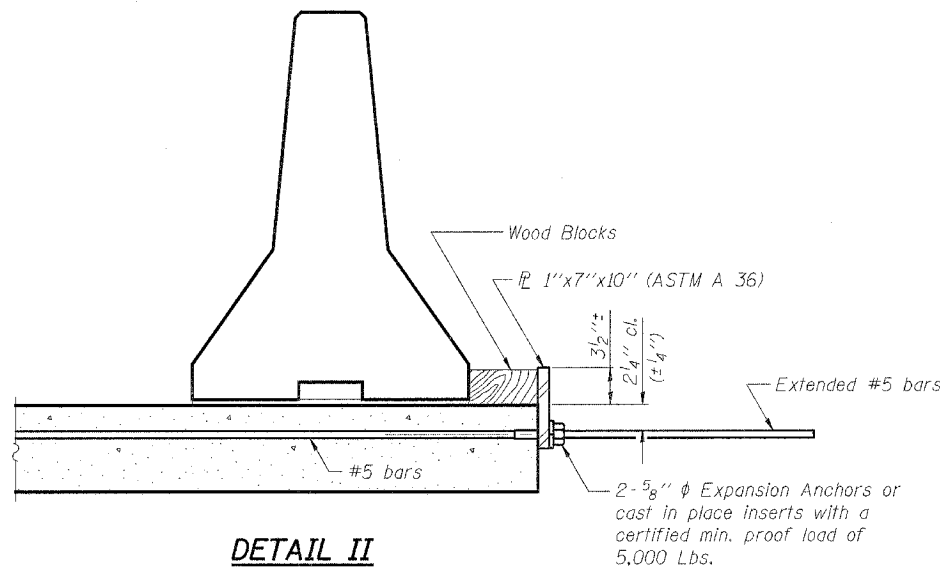

DETAIL II

The 1"x7"x10" Plate shall not be removed until Stage II Construction forms and all reinforcement bars are in place and the concrete is ready to be placed.

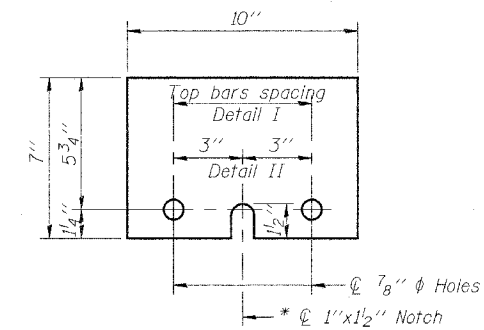

\bar{P} 1"x7"x10"

* Required only with Detail II

DESIGNED	I.D.O.T.
CHECKED	S.C. Crawley
DRAWN	I.D.O.T.
CHECKED	S.C. Crawley

TEMPORARY CONCRETE BARRIER
FOR STAGE CONSTRUCTION
ILLINOIS ROUTE 100 OVER
WALNUT CREEK
F.A.P. ROUTE 562 - SECTION 117(B-4)
SCOTT COUNTY
STATION 300+50.00
STRUCTURE NO. 086-7500