

FED. PROJECT NO.	SECTION	COUNTY	TOTAL SHEETS	SHEET NO.
754	4RS-2, 4BR	CALHOUN	87	18
STA.	TO STA.			

EXISTING CONDITIONS:  
CONTRACT NO. 76269

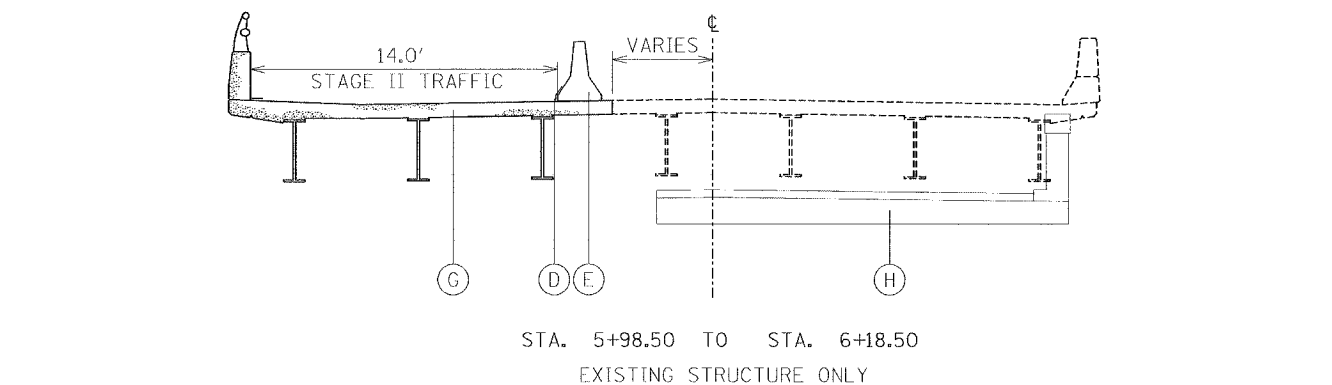
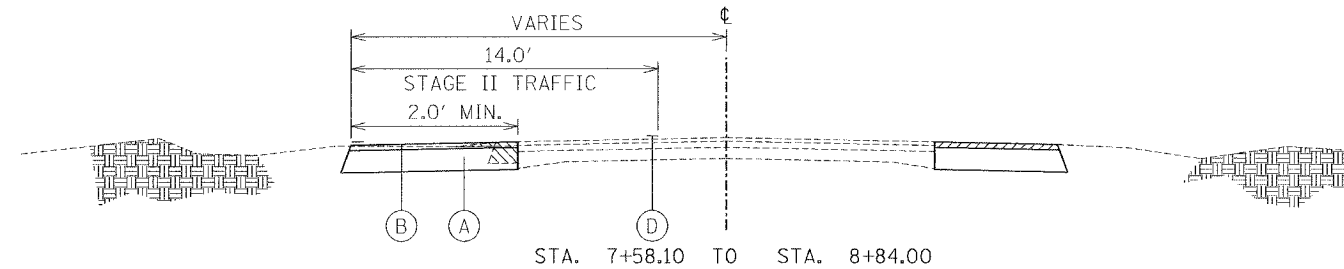
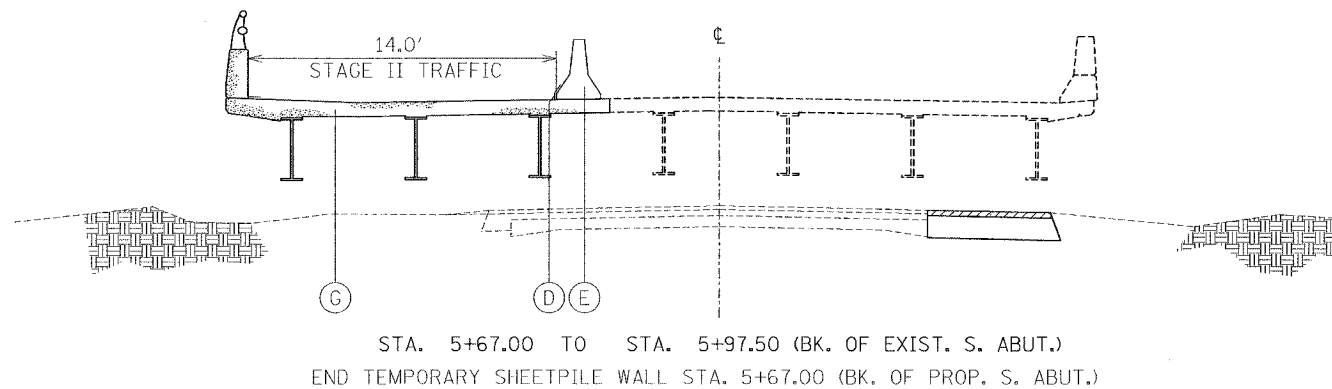
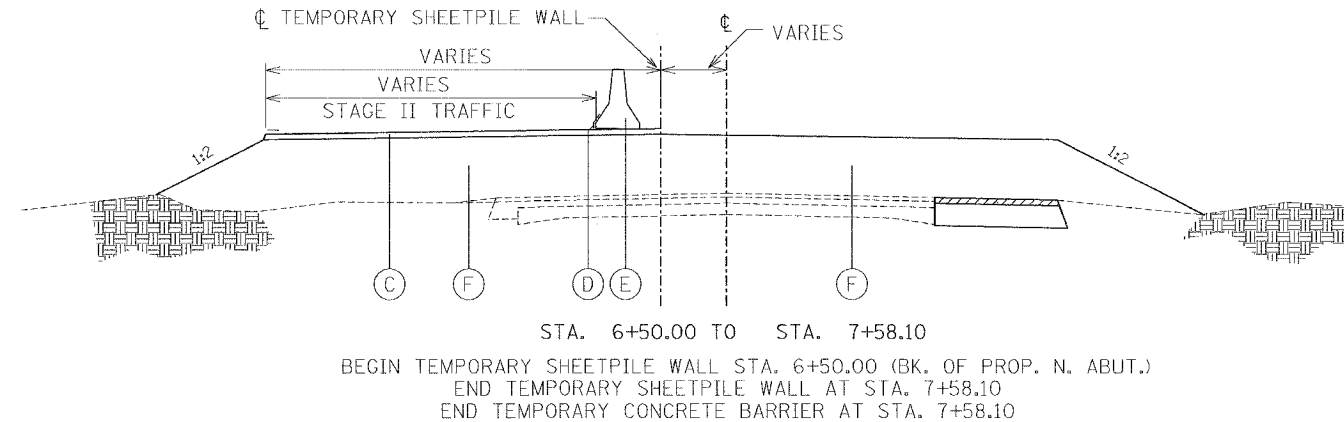
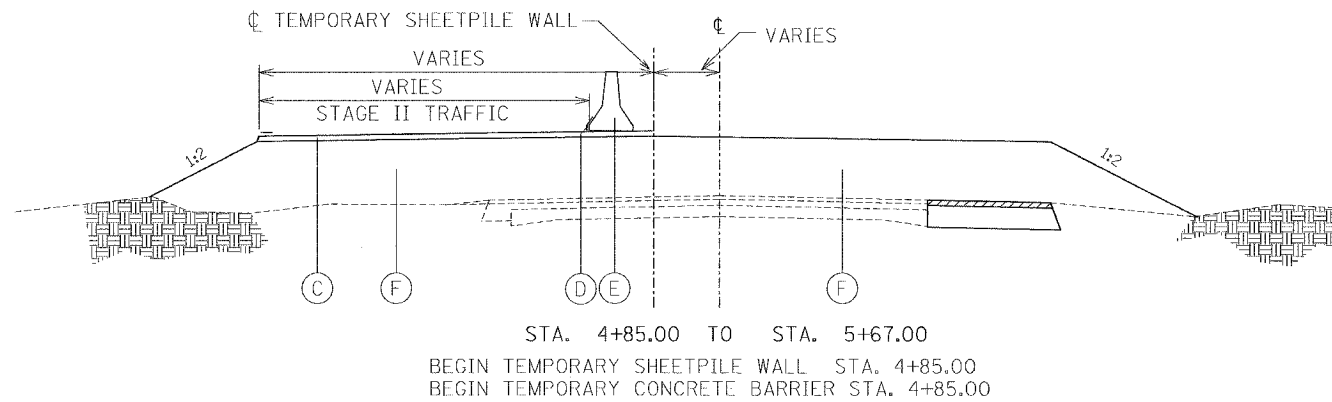
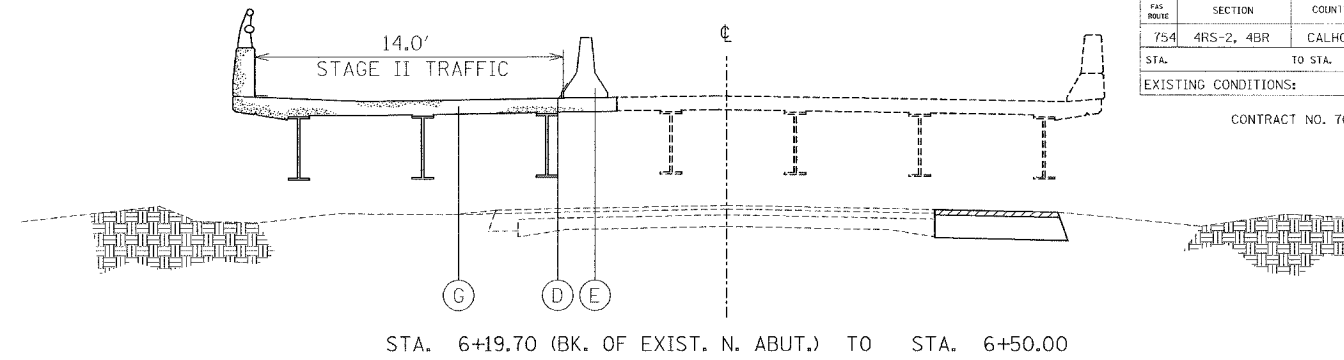
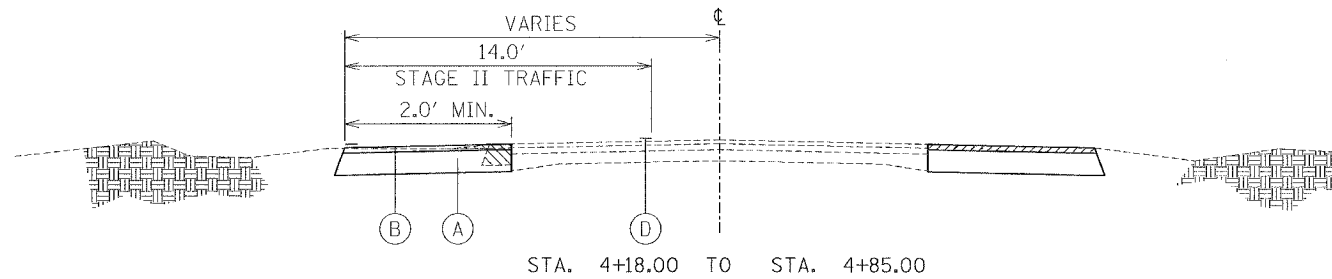

SEQUENCE OF CONSTRUCTION  
In general, this project shall be stage constructed as follows:

- Standards
- 701301-01 Lane Closure 2L, 2W Short Time Operations
  - 701321-06 Lane Closure 2L, 2W Bridge Repair With Barrier
  - 701501-01 Lane Closure 2L, 2W Undivided for Speeds < 15 MPH
  - 702001-03 Traffic Control Devices
  - 704001-01 Temporary Concrete Barrier

- Stage II
1. Relocate temporary concrete barrier, install temporary pavement markings, relocate traffic control for stage II and place northbound traffic on southbound lane.
  2. Remove remainder of existing structure and complete construction of proposed structure.
  3. Place granular embankment on northbound lanes equal in height to the southbound lanes and to the limits of the proposed pavement width (as shown in the typical sections).



\* THE BOTTOM 6" ON THE TRAFFIC FACE OF THE TEMPORARY CONCRETE BARRIER SHALL BE PAINTED WITH TEMPORARY PAVEMENT MARKING "WHITE". THE COST SHALL BE PAID AS TEMPORARY PAVEMENT MARKING - LINE, 6".

- A. PROPOSED TEMPORARY AGGREGATE BASE, TYPE B, 8" (TO BE COMPLETED PRE-STAGE I)
- B. PROPOSED TEMPORARY BITUMINOUS CONCRETE BINDER COURSE, SUPERPAVE, IL-19.0, N50, 4" (TO BE COMPLETED PRE-STAGE I)
- C. PROPOSED TEMPORARY RAMP (PAID AS BITUMINOUS CONCRETE BINDER COURSE, SUPERPAVE, IL-19.0, N50, 3 1/2")
- D. PROPOSED TEMPORARY PAVEMENT MARKING LINE, 4" OR 6" ON BOTTOM OF BARRIER IF PRESENT \*
- E. PROPOSED TEMPORARY CONCRETE BARRIER
- F. PROPOSED GRANULAR EMBANKMENT, TYPE B, VARIES
- G. PROPOSED GRANULAR EMBANKMENT, TYPE B, VARIES
- G. PROPOSED STRUCTURE
- H. EXISTING STRUCTURE
- I. BITUMINOUS SHOULDER REMOVAL, 2' WIDTH

REVISIONS		ILLINOIS DEPARTMENT OF TRANSPORTATION
NAME	DATE	
		<b>STAGE II TYPICAL SECTIONS</b> F.A.S. 754 (PARK ST.) SECTION 4RS-2, 4BR CALHOUN COUNTY

DATE AUGUST, 2005  
DRAWN BY WJS  
CHECKED BY LLO