

SECTION NO.	COUNTY HIGHWAY	COUNTY	SHEET
00-00196-08-BR	47	ST. CLAIR	9 OF 18
FHWA REG. NO. 7	ILLINOIS	FEDERAL AID PROJECT	
CONTRACT 97257			

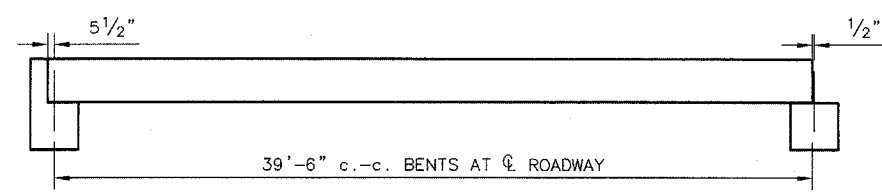

TYPICAL ELEVATION

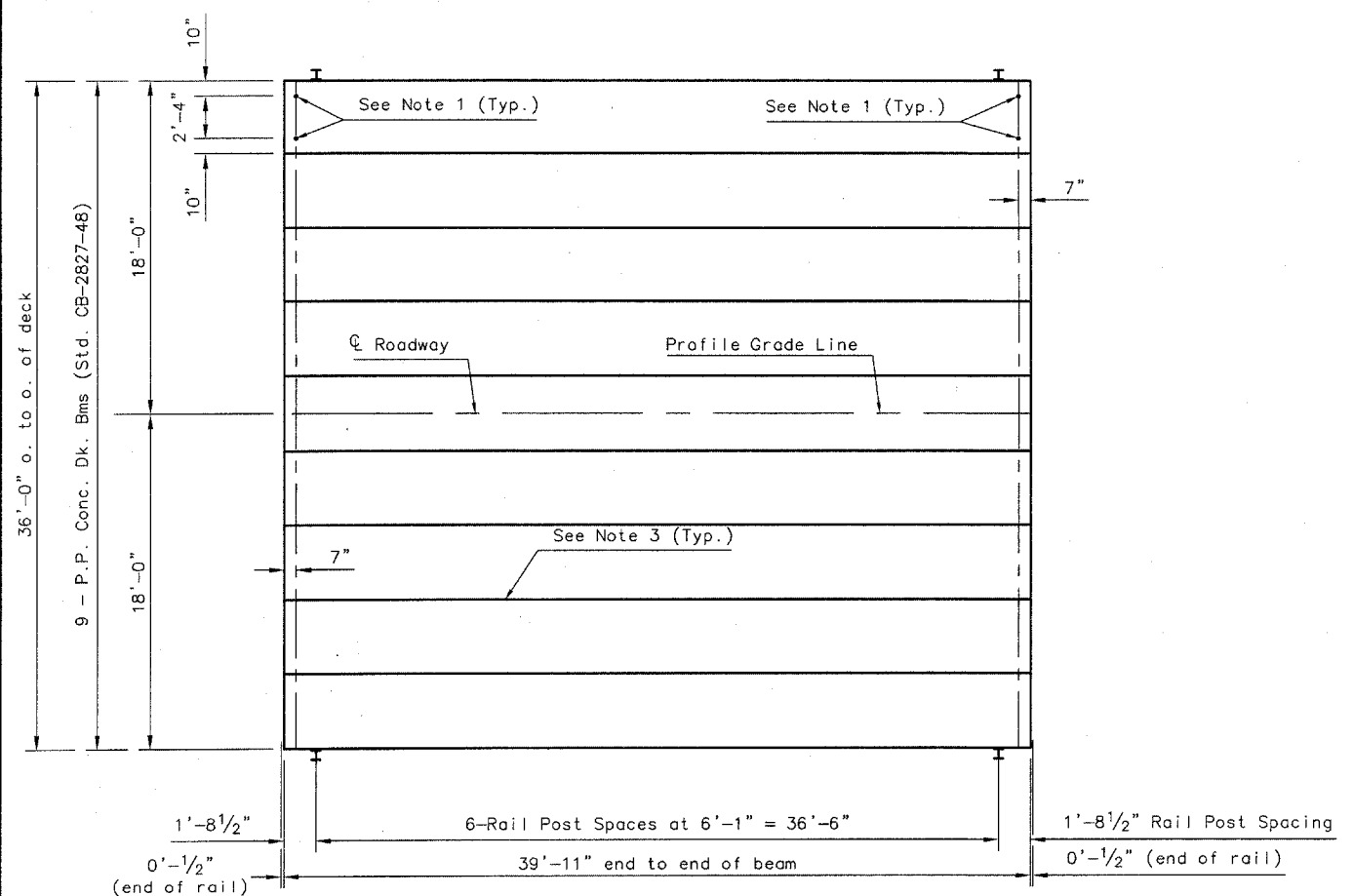

PLAN

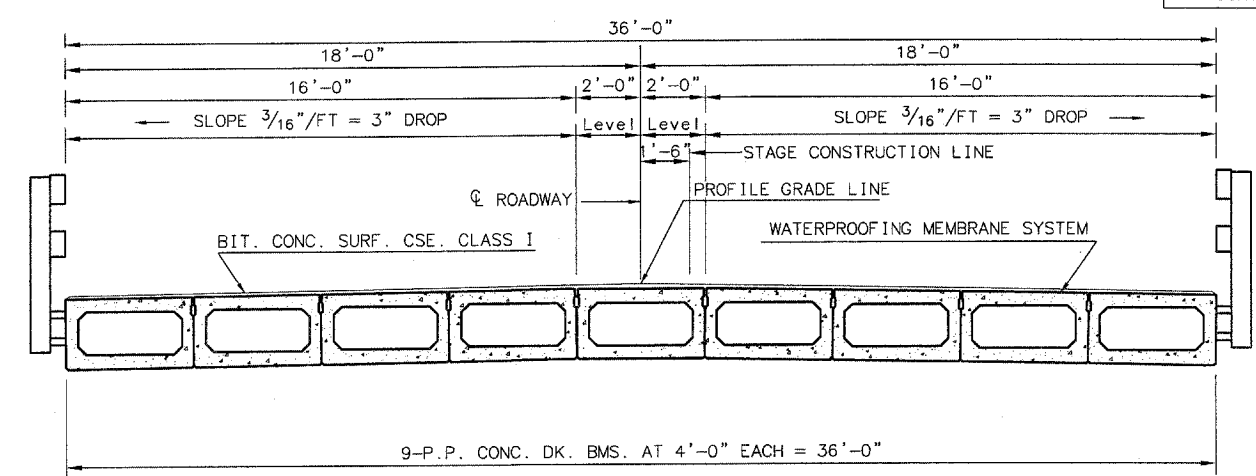

CROSS SECTION
(LOOKING EAST)

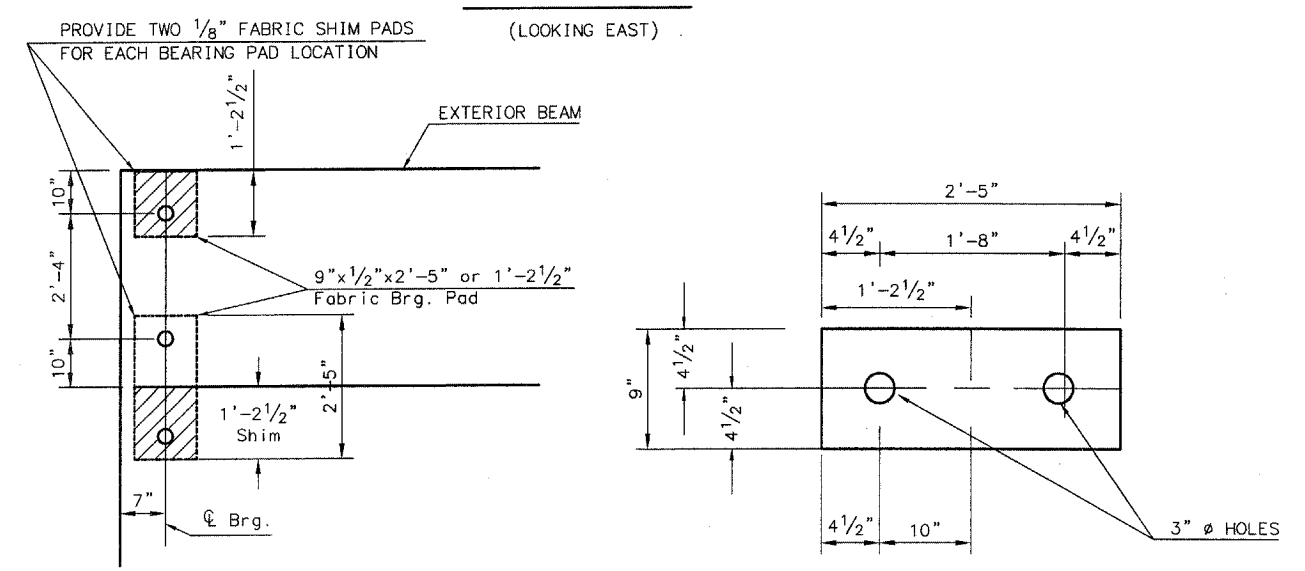

1/2" FABRIC BRG. PAD DETAILS

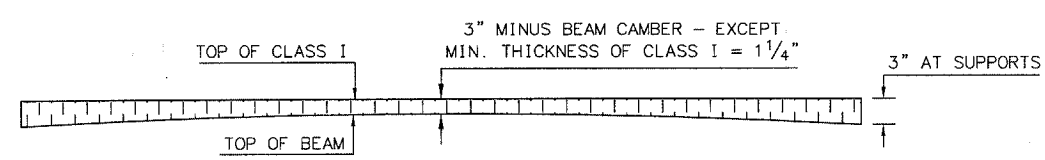

PROFILE OF OVERLAY

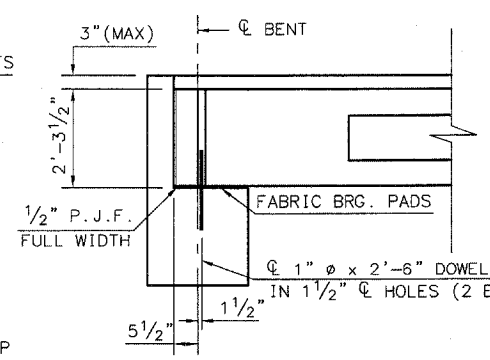

SECTION AT ABUTS.
(ALONG CL BEAMS)

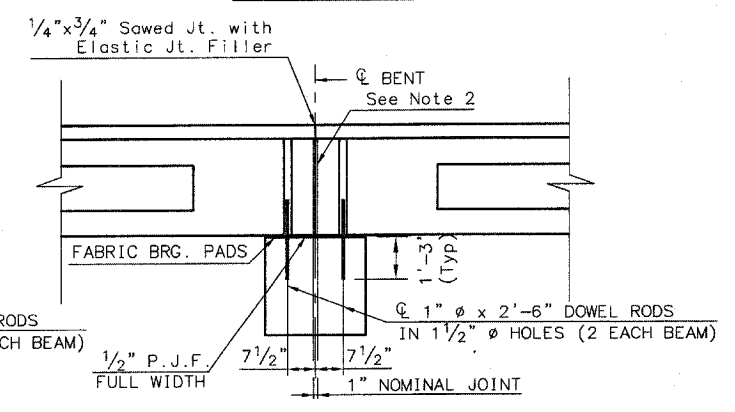

SECTION AT PIERS
(ALONG CL BEAMS)

- NOTES**
- AFTER BEAMS HAVE BEEN ERECTED, HOLES SHALL BE DRILLED INTO SUBSTRUCTURE AND ANCHOR DOWELS PLACED. DOWEL HOLES SHALL BE FILLED WITH NON-SHRINK GROUT TO TOP OF BEAM AND ALLOWED TO CURE MIN. 24 HRS. PRIOR TO GROUTING THE SHEAR KEYS.
 - NOMINAL 1" JOINT AT CL PIER SHALL BE FILLED WITH NON-SHRINK GROUT.
 - LONGITUDINAL KEYS SHALL BE GROUTED.
 - SEE SHEET 3 FOR SHEAR KEY CLAMPING DETAILS.
 - SEE SHEETS 5 & 6 FOR STAGE CONSTRUCTION DETAILS.

QUANTITIES FOR ONE SPAN

P.P. CONC. DK. BM. 27" DP.	1437 SQ FT
STEEL RAILING, TYPE S1	80 FT
BCSC SUPER "C" N50	31 TONS
WATERPROOFING MEMBRANE SYSTEM	159.7 SQ YD

P.P.C. DECK BEAM SUPERSTRUCTURE	
36' RDWY.	27" BMS.
40' SPAN	0° SKEW

INITIALS	DATE
DESIGNED JLH	8/04
CHECKED	
DRAWN JLH	10/04
CHECKED	
PREPARED BY ST. CLAIR COUNTY	
CADD DRAWING FILE: SUPERSTR	