

HORIZONTAL & VERTICAL CONTROL

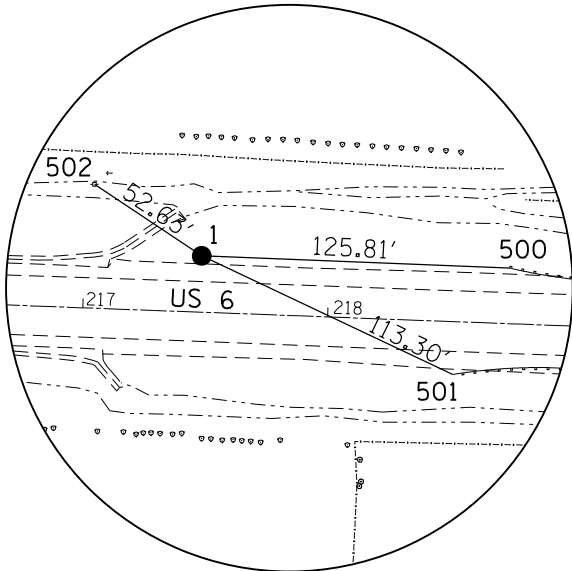

HORIZONTAL CONTROL
POINT NO. 1

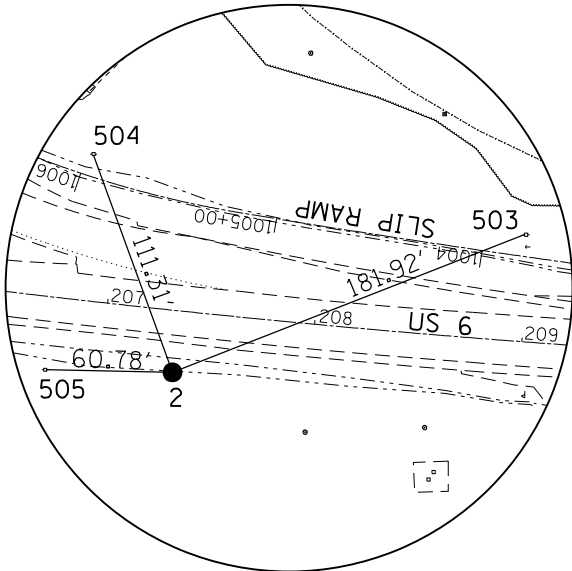

HORIZONTAL CONTROL
POINT NO. 2

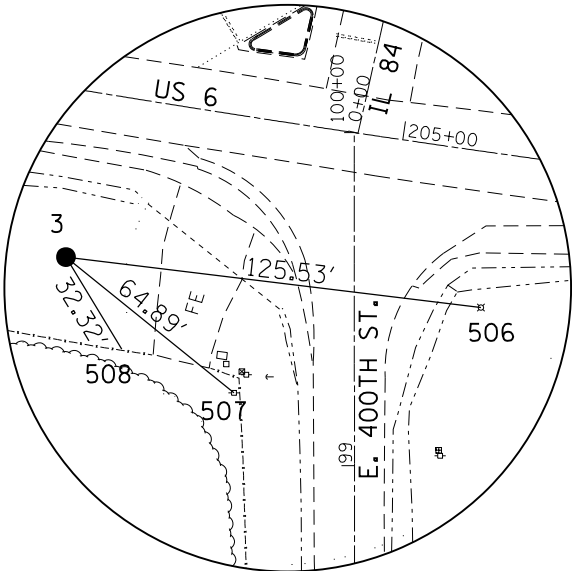

HORIZONTAL CONTROL
POINT NO. 3

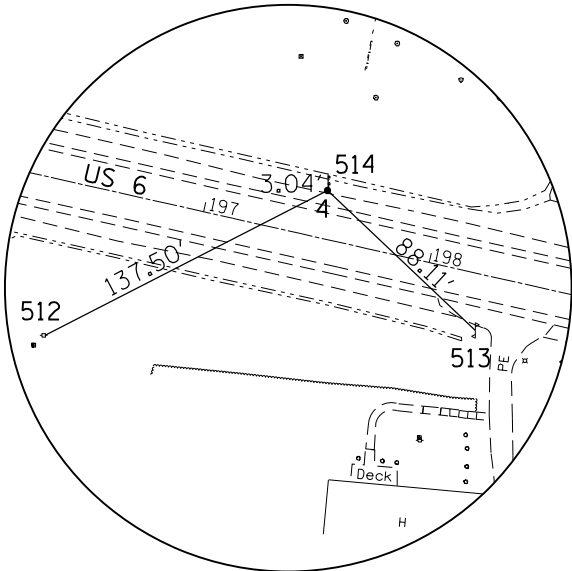

HORIZONTAL CONTROL
POINT NO. 4

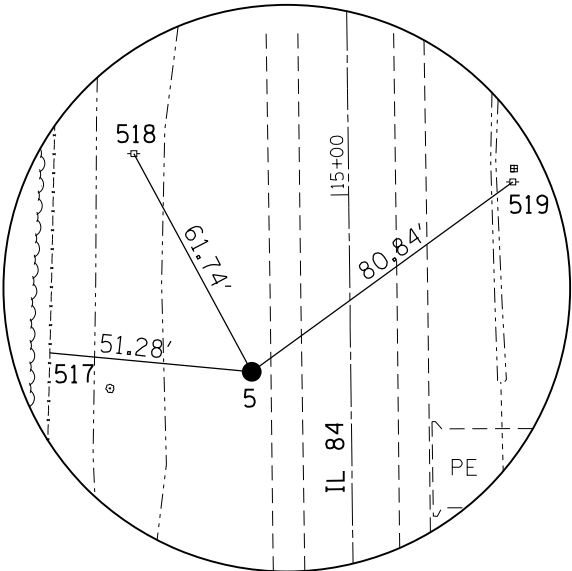

HORIZONTAL CONTROL
POINT NO. 5

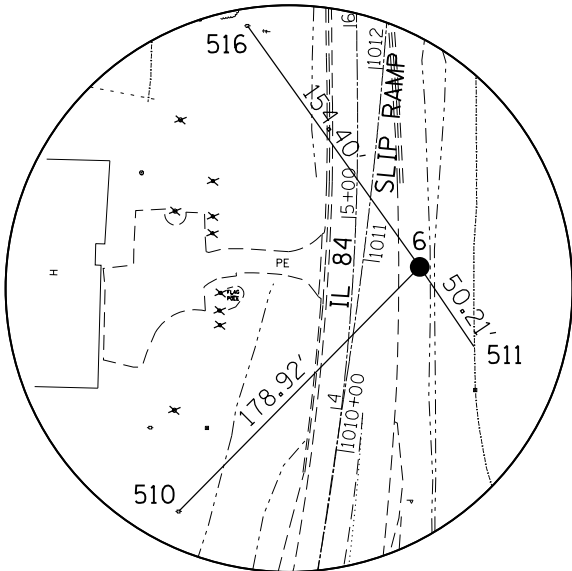

HORIZONTAL CONTROL
POINT NO. 6

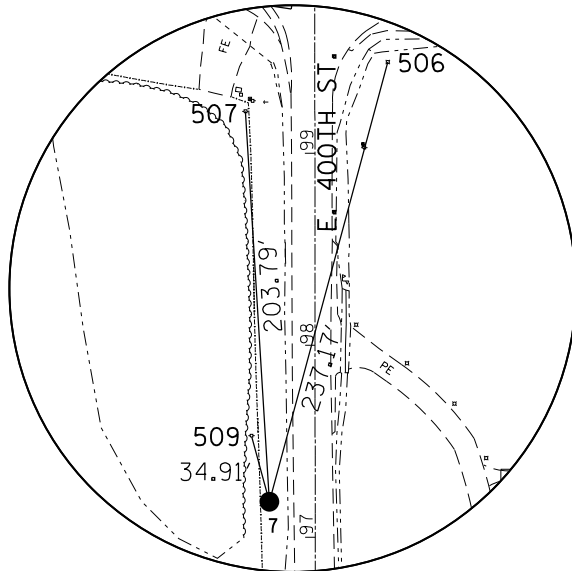

HORIZONTAL CONTROL
POINT NO. 7

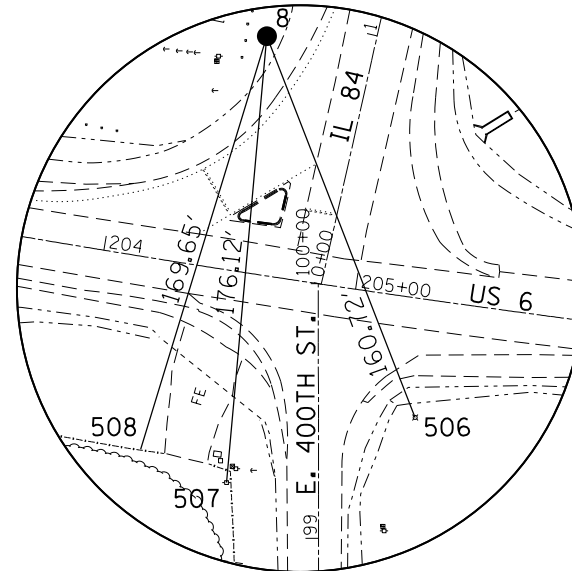

HORIZONTAL CONTROL
POINT NO. 8

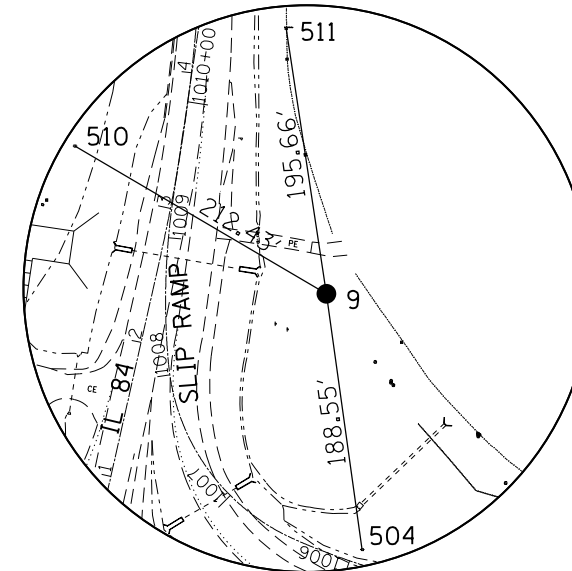

HORIZONTAL CONTROL
POINT NO. 9

FILE NAME =	USER NAME = cushmenbw	DESIGNED -	REVISED -
c:\pwork\work\pwork\cushmenbw\d0333009\0201709-sh1-ATB.dgn		DRAWN -	REVISED -
Default	PLOT SCALE = 100.0000' / 1in.	CHECKED -	REVISED -
	PLOT DATE = Fri Aug 01 11:26:45 2014	DATE -	REVISED -

**STATE OF ILLINOIS
DEPARTMENT OF TRANSPORTATION**

HORIZONTAL & VERTICAL CONTROL SHEETS			
SCALE:	SHEET	OF SHEETS	STA. TO STA.

F.A.U. RTE.	SECTION	COUNTY	TOTAL SHEETS	SHEET NO.
*	2R-1	HENRY	235	33
			CONTRACT NO. 64J43	
ILLINOIS FED. AID PROJECT				

* 5789 & 5861