

FABRIC BEARING PAD
(Interior)

FABRIC BEARING PAD
(Exterior)

FIXED

SECTION A-A

Note: All bearing pads shall be 1" thick.

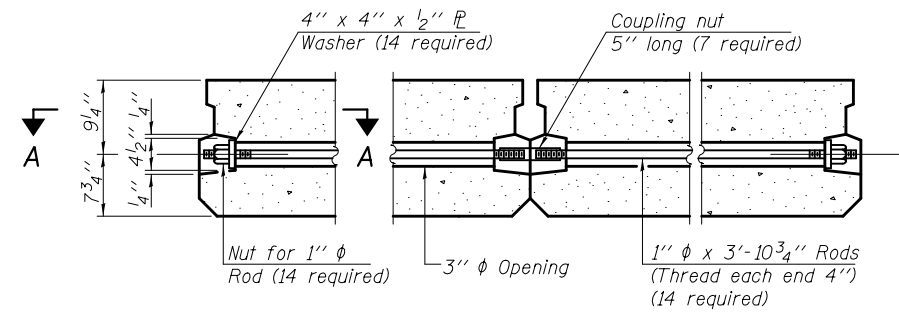

TYPICAL TRANSVERSE TIE ASSEMBLY

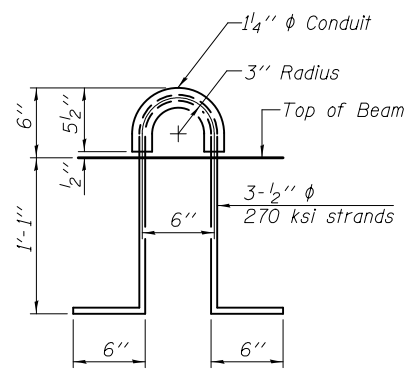
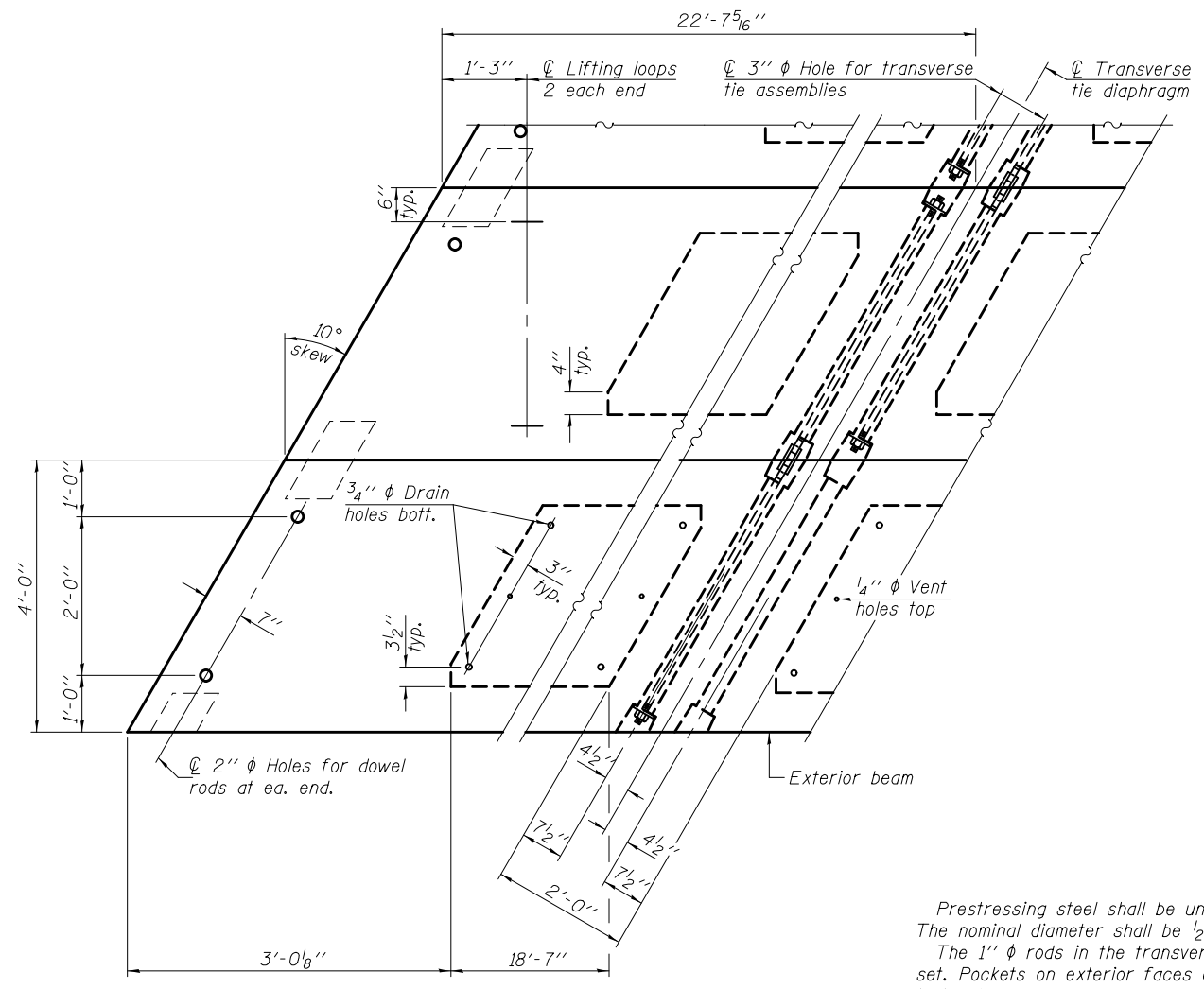
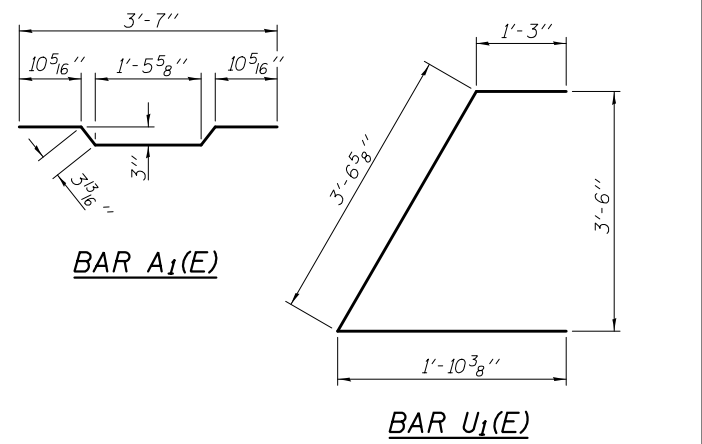
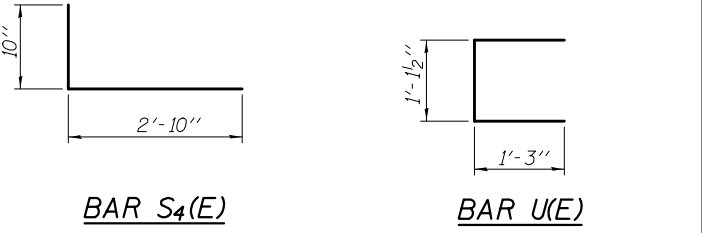
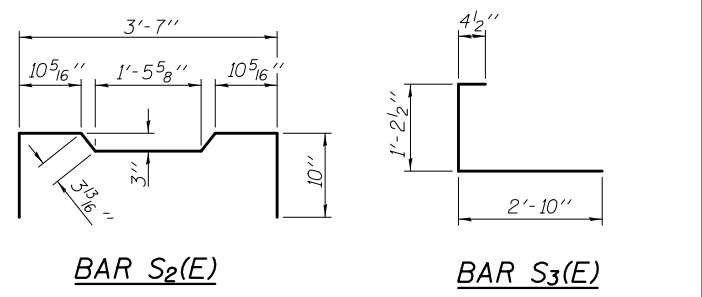
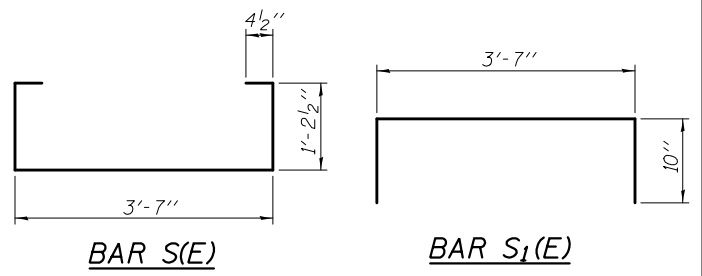

LIFTING LOOP DETAIL

NOTES

Prestressing steel shall be uncoated high strength, low relaxation 7-wire strand, Grade 270. The nominal diameter shall be 1/2" and the nominal cross-sectional area shall be 0.153 sq. in. The 1" phi rods in the transverse tie assembly shall be tightened to a snug fit and the threads set. Pockets on exterior faces of bridge shall be filled with grout after transverse tie assembly is in place. Reinforcement bars shall conform to ASTM A 706, Grade 60. Two 1/8" fabric adjusting shims of the dimensions of the exterior bearing pad shall be provided for each bearing pad location. A minimum 2 1/2" phi lifting pin shall be used to engage the lifting loops during handling. Corrosion Inhibitor, per Article 1020.05(b)(12) and 1021.06 of the Standard Specifications, shall be used in the concrete for precast prestressed concrete deck beams. Compressive strength of prestressed concrete, f'c, shall be 6000 psi. Compressive strength of prestressed concrete at release, f'ci, shall be 5000 psi.

BILL OF MATERIAL

Precast Prestressed Concrete Deck Beams (17" depth)	Sq. Ft.	1447
---	---------	------

PD-1748-LD 7-1-10

DESIGNED - Fess Teklehmanot	EXAMINED - <i>Joanne F. [Signature]</i>	DATE - SEPTEMBER 3, 2014
CHECKED - Ray Ahanchi	PASSED - <i>Carl [Signature]</i>	REVISED -
DRAWN - h.t. duong	ACTING ENGINEER OF BRIDGES AND STRUCTURES	REVISED -
CHECKED - FT/GRA		

STATE OF ILLINOIS
DEPARTMENT OF TRANSPORTATION

17" x 48" PPC DECK BEAM DETAILS
STRUCTURE NO. 038-0184

SHEET NO. 9 OF 11 SHEETS

F.A.S. RTE.	SECTION	COUNTY	TOTAL SHEETS	SHEET NO.
1324	38BR	IROQUOIS	35	22
CONTRACT NO. 66A72				
ILLINOIS FED. AID PROJECT				