

EAST EDGE OF SLAB

Location	Station	Offset	Theoretical Grade Elevations	Theoretical Grade Elevations Adjusted For Grinding
S. End Bridge Deck	198+24.73	-23.00	761.97	761.99
J	198+34.73	-23.00	761.86	761.88
K	198+44.31	-23.00	761.74	761.76
L	198+44.73	-23.00	761.73	761.76
End S. Appr. Slab	198+54.73	-23.00	761.59	761.61

EAST EDGE OF PAVEMENT

Location	Station	Offset	Theoretical Grade Elevations	Theoretical Grade Elevations Adjusted For Grinding
S. End Bridge Deck	198+23.84	-18.00	761.82	761.84
J	198+33.84	-18.00	761.72	761.74
K	198+43.43	-18.00	761.60	761.62
L	198+43.84	-18.00	761.60	761.62
End S. Appr. Slab	198+53.84	-18.00	761.45	761.47

☉ F.A.P. 730 & P.G.L.

Location	Station	Offset	Theoretical Grade Elevations	Theoretical Grade Elevations Adjusted For Grinding
S. End Bridge Deck	198+20.67	0.00	762.12	762.14
J	198+30.67	0.00	762.02	762.05
K	198+40.26	0.00	761.91	761.93
L	198+40.67	0.00	761.91	761.93
End S. Appr. Slab	198+50.67	0.00	761.77	761.79

STAGE CONSTRUCTION LINE

Location	Station	Offset	Theoretical Grade Elevations	Theoretical Grade Elevations Adjusted For Grinding
S. End Bridge Deck	198+20.41	1.50	762.10	762.12
J	198+30.41	1.50	762.00	762.03
K	198+39.99	1.50	761.89	761.91
L	198+40.41	1.50	761.89	761.91
End S. Appr. Slab	198+50.41	1.50	761.75	761.77

WEST EDGE OF PAVEMENT

Location	Station	Offset	Theoretical Grade Elevations	Theoretical Grade Elevations Adjusted For Grinding
S. End Bridge Deck	198+17.85	16.00	761.91	761.93
J	198+27.85	16.00	761.81	761.83
K	198+37.43	16.00	761.71	761.73
L	198+37.85	16.00	761.70	761.72
End S. Appr. Slab	198+47.85	16.00	761.57	761.59

WEST EDGE OF SLAB

Location	Station	Offset	Theoretical Grade Elevations	Theoretical Grade Elevations Adjusted For Grinding
S. End Bridge Deck	198+16.97	21.00	762.06	762.09
J	198+26.97	21.00	761.97	761.99
K	198+36.55	21.00	761.87	761.89
L	198+36.97	21.00	761.86	761.88
End S. Appr. Slab	198+46.97	21.00	761.73	761.76

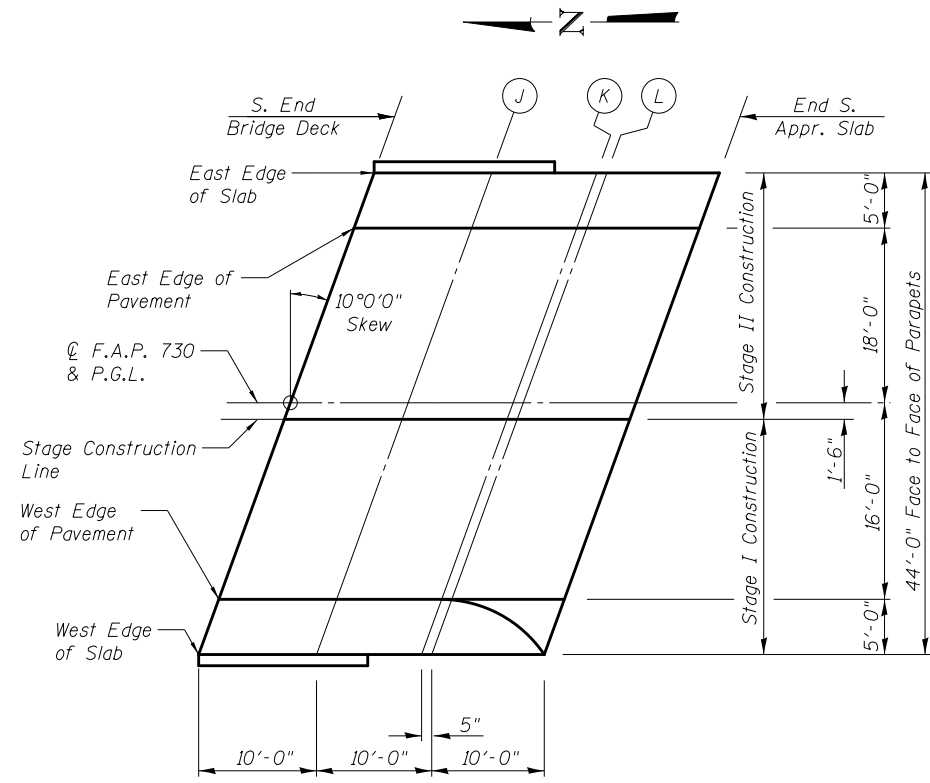

PLAN



USER NAME = ceerlockjd	DESIGNED - VPT	REVISED
	CHECKED - THW	REVISED
PLOT SCALE = 0:2.0000 ' / in.	DRAWN - THW	REVISED
PLOT DATE = 8/12/2014	CHECKED - VPT	REVISED

**STATE OF ILLINOIS
DEPARTMENT OF TRANSPORTATION**

**TOP OF SOUTH APPROACH SLAB ELEVATIONS
STRUCTURE NO. 057-0256**

SHEET NO. 8 OF 23 SHEETS

F.A.P. RTE.	SECTION	COUNTY	TOTAL SHEETS	SHEET NO.
730	62-ZBR	MCLEAN	65	35
CONTRACT NO. 70540				
ILLINOIS FED. AID PROJECT				