

**PUBLIC ROAD**

**COMMERCIAL (P.C.C.)**

**COMMERCIAL (HOT-MIX ASPHALT)**

**PRIVATE ENTRANCE (P.C.C.)**

**PRIVATE ENTRANCE (HOT-MIX ASPHALT)**

**FIELD ENTRANCE (AGGREGATE)**

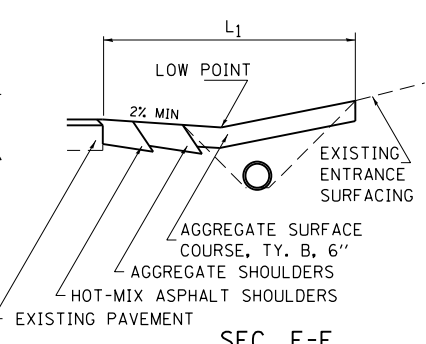
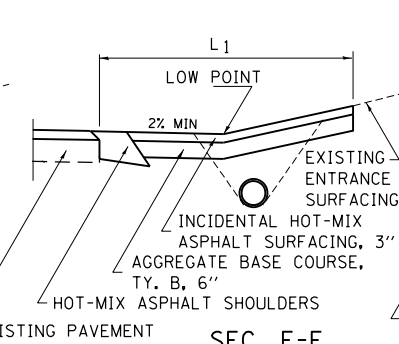
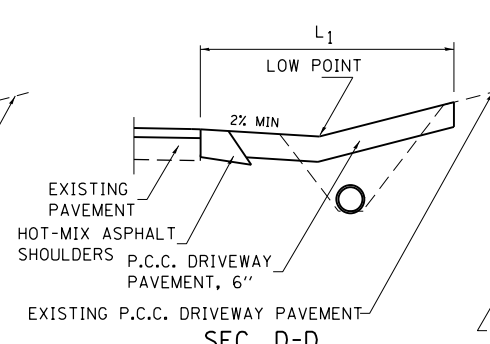
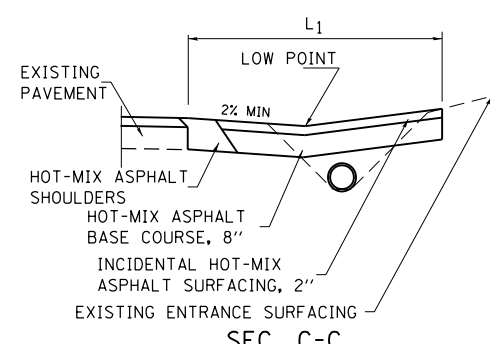
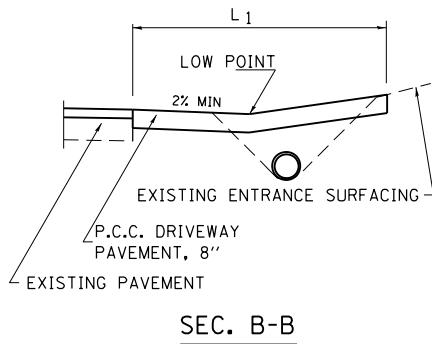
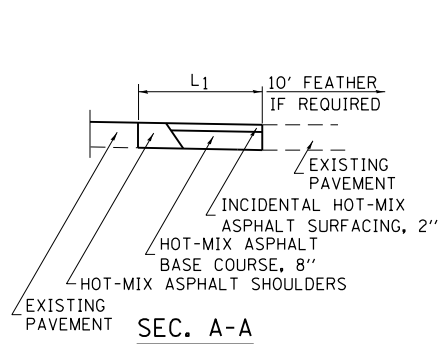
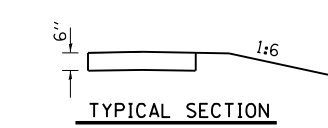
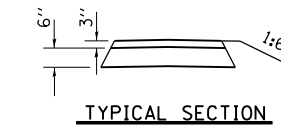
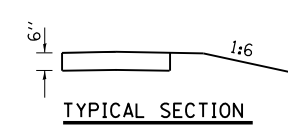
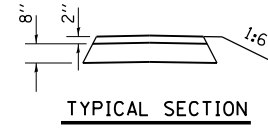
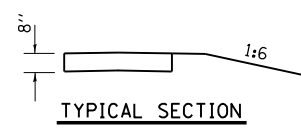
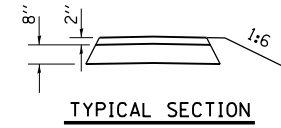

**ENTRANCE SCHEDULE**

TYPE	SIDE/STATION	WIDTH	LENGTH		RADII	AGGREGATE BASE COURSE, TY. B, 6"		INCIDENTAL HOT-MIX ASPHALT SURFACING	P.C.C. DRIVEWAY PAVEMENT		PCC PAVEMENT 8"
			L <sub>1</sub>	L <sub>2</sub>		TON	SO. YD.		6"	8"	
PE	LT 135+26	12	14	19	15	19.5		9.6			
PE	RT 136+06	13	15	8	15	15.3		7.5			
PE	LT 137+75	24	10	30	10	38.3		18.8			
PE	LT 139+70	19	15	21	15	29.2		14.3			
PE	LT 142+06	12	14	22	15	20.1		9.9			
PE	LT 144+16	14	16	20	15	24.8		12.2			
PE	LT 150+00	24	20	30	15	54.7		26.9			
PE	LT 154+22	14	20	15	20	25.3		12.5			
	TOTALS					227.0		112.0			

**ENTRANCE SCHEDULE**

TYPE	SIDE/STATION	WIDTH	LENGTH		RADII	AGGREGATE BASE COURSE, TY. B, 6"		INCIDENTAL HOT-MIX ASPHALT SURFACING	P.C.C. DRIVEWAY PAVEMENT		PCC PAVEMENT 8"
			L <sub>1</sub>	L <sub>2</sub>		TON	SO. YD.		6"	8"	

**NOTES**

L<sub>1</sub> = DISTANCE FROM EDGE OF PAVEMENT TO RADIUS POINT OR MAXIMUM DISTANCE OF 30'.  
 L<sub>2</sub> = DISTANCE FROM RADIUS POINT OR MAXIMUM DISTANCE OF 30' FROM EDGE OF PAVEMENT TO R.O.W. LINE  
 MATERIAL USED TO CONSTRUCT L<sub>2</sub> LENGTH SHALL BE THE SAME TYPE OF MATERIAL AS THE EXISTING ENTRANCE

THE THICKNESS OF THE HOT-MIX ASPHALT SHOULDERS THROUGH COMMERCIAL ENTRANCES (HOT-MIX ASPHALT) AND PUBLIC ROADS SHALL BE 10". THE COST OF THE EXTRA THICKNESS SHALL BE INCLUDED WITH THE HOT-MIX ASPHALT SHOULDERS PAY ITEM.

THE COST OF THE BITUMINOUS MATERIALS AND AGGREGATE (PRIME COAT) FOR ENTRANCES AND PUBLIC ROAD APPROACHES SHALL BE INCLUDED IN THE PAY ITEM INCIDENTAL HOT-MIX ASPHALT SURFACING.

HOT-MIX ASPHALT SHOULDERS SHALL NOT BE CONSTRUCTED THROUGH PCC ENTRANCE OR PUBLIC ROAD APPROACH.

FE=FIELD ENTRANCE PRA - PUBLIC ROAD APPROACH  
 PE=PRIVATE ENTRANCE MBT - MAILBOX TURNOUT  
 CE=COMMERCIAL ENTRANCE

FILE NAME =	USER NAME = steffenmk	DESIGNED -	---	REVISED -	03-13-07
ei:\pw\work\p\dot\steffenmk\dms52738\0774246-sht-sch.dgn		DRAWN -		REVISED -	
		PLOT SCALE = 100.0000' / 1"		REVISED -	
		PLOT DATE = 8/13/2014		REVISED -	

**STATE OF ILLINOIS DEPARTMENT OF TRANSPORTATION**

**ENTRANCE SCHEDULE AND MAILBOX TURNOUT DETAILS WITH BASE COURSE WIDENING**

SCALE: N/A SHEET NO. 3 OF 3 SHEETS STA. TO STA.

F.A.S. R.E.	SECTION	COUNTY	TOTAL SHEETS	SHEET NO.
1806	(2,2Z)RS-2, (2N)	LAWRENCE	82	17
CONTRACT NO. 74246				
FED. ROAD DIST. NO. ILLINOIS FED. AID PROJECT				